



Important!

Please give copies to all your VW Technicians

Technical Bulletin

Subject: **Shifter Lever, Vibrating/Knocking**

Group: **34**

Number: **99-04**

Model(s): **New Beetle, Golf, New Jetta with 02J Transmission**

2000

Date: **Dec 7, 1999**

Condition

Shifter lever vibrating/knocking in 1st, 2nd, 3rd or 4th gears.

May be caused by transmission vibrations traveling through the selector shaft and shifter cables to the shifter lever.

Service

For vehicles with this condition perform the following:

Note:

For New Beetle, see Golf/Jetta Repair Manual until next VESIS release 00-1 (procedures are similar).

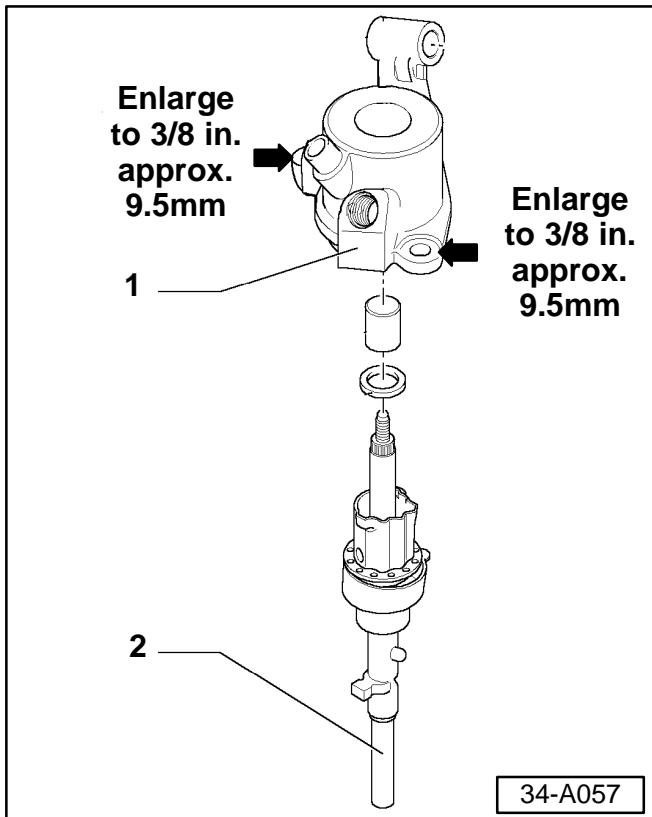

- ◀ - Remove selector mechanism cover -1- from transmission, see Repair Manual "Gear Selector Mechanism (from 5/99), servicing".
- Remove selector shaft -2-, see Repair Manual "Transmission Selector Mechanism (from 5/99), disassembling and assembling".
- Enlarge both selector shaft housing attachment holes -arrows- to 3/8 in. (approx. 9.5mm).
- Install Part No: 02J 301 233C (selector shaft -2-) see Repair Manual "Transmission Selector Mechanism (from 5/99), disassembling and assembling".
- Reinstall selector mechanism cover -1- into transmission using sealant AMV 188 200 03 or equivalent.
- If necessary adjust Shift cables see "Gear Selector Mechanism (from 5/99), servicing".

(Cont. page 2)



Important!

Please give copies to all your VW Technicians

Technical Bulletin

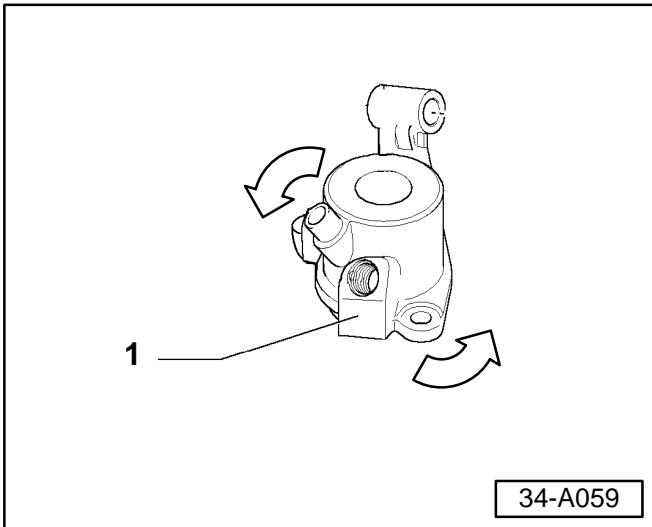
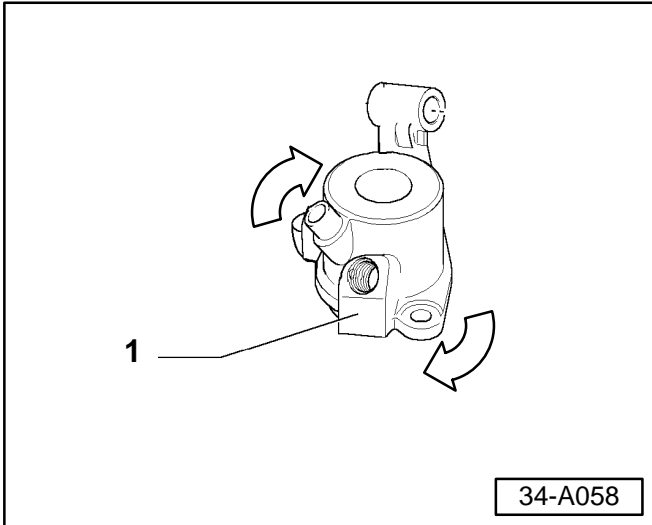

- If necessary, adjust according to one of the following conditions.

Vibration/knocking from 1st or 3rd gear:

- Loosen selector mechanism.

Illustration shows selector mechanism housing with shaft and cables removed.

- ◀ - Turn housing -1- right (clockwise as far as possible).
- Tighten selector mechanism bolts to 25 Nm. (18 ft. lb.).

Vibration/knocking from 2nd or 4th gear:

- Loosen selector mechanism.

Illustration shows selector mechanism housing with shaft and cables removed.

- ◀ - Turn housing -1- left (counter clockwise as far as possible).
- Tighten selector mechanism bolts to 25 Nm. (18 ft. lb.).
- Road test vehicle.

CAUTION!

Part numbers are for reference only. Always check with your Parts Dept. for the latest parts information.

- If **minor** vibration/knocking is still present, readjust selector shaft housing (see previous steps).

When procedure applies to vehicles within the New Vehicle Limited Warranty, use the following:

Part Identifier: 3445

Labor Operation: 3445510 160 TU