



Audi A3 '13



The material in this Self Study Program (SSP) may contain technical information or reference vehicle systems and configurations which are not available in the Canadian market.

Please ensure you reference ElsaPro for the most current technical information and repair procedures.

The Audi A3 can look back on a 16-year success story. The first generation of the series, which debuted in 1996 as a three-door, established an entirely new market segment – the premium compact class. In 1999 the five-door hatchback and the sporty Audi S3 completed the family. In total, around 990,000 units were sold. The second generation, launched in 2003, was even more successful, achieving sales of around 1.8 million units. In the emerging competition, the A3 was the dominant force in the premium compact class.

The Group has set itself the task of improving the fuel economy of its internal combustion engines, extending its product range to include alternative drive systems such as natural gas engines and electric motors, and equipping as many vehicles as possible with the latest technical innovations. The basis for implementing these objectives is the Modular Transverse Platform (MTP), a standardised architecture on which various vehicle components can be combined in any configuration on modular principles. This broadens the diversity of the model range, resulting in more efficient production, engines and combinations of materials.

The Audi A3 '13 represents the cumulative technological expertise of Audi in a compact format. In its lightweight body, its interior architecture and its user interfaces, this three-door model is once again setting standards in its class. Its engines impress with their efficiency and power, and the range of driver assistance systems and infotainment solutions is unparalleled in the premium compact class.

The progressive formal language visualises the sheer passion with which Audi develops and makes cars. Ultra-lightweight design has long been a success formula and a hallmark of the Audi brand. This is by no means confined to a single, specific material. On the contrary, Audi's motto is: "The right material in the right place for optimal function". True to this maxim, the engineers have developed a multi-material body for the new A3.

The lightweight body and downsized engines have had major knock-on effects throughout the vehicle, reducing the weight of many suspension, exhaust and interior components. At launch, Audi will supply the A3 '13 with one TDI engine and two TFSI engines. The Modular Infotainment Platform (MIB) makes its debut in the Audi A3 '13 – it represents a big step forward in mobile communication electronics. The Audi A3 '13 also sets new standards in the premium compact class when it comes to driver assistance systems. The most important of these is Audi adaptive cruise control. In the event of an impending collision, the ACC system warns the driver in progressive stages and, if necessary, can initiate partial braking in order to reduce the car's speed at impact.



609_047

The Self Study Programme teaches a basic knowledge of the design and functions of new models, new automotive components or new technologies.

It is not a Repair Manual! Figures are given for explanatory purposes only and refer to the data valid at the time of preparation of the SSP.

For further information about maintenance and repair work, always refer to the current technical literature.



Note



Reference

Introduction

| | |
|----------|---|
| In brief | 4 |
|----------|---|

Body

| | |
|-----------------------|----|
| Body structure | 6 |
| Attachments | 8 |
| Joining techniques | 8 |
| Panorama tilt sunroof | 10 |
| Bumper system | 12 |
| Underbody | 13 |
| Tow bar | 13 |

Passive safety

| | |
|-----------------------|----|
| Components | 14 |
| System overview | 15 |
| Airbag systems | 16 |
| Seat occupancy sensor | 18 |
| Pedestrian protection | 20 |

Active safety

| | |
|----------------|----|
| Audi pre sense | 22 |
|----------------|----|

Engines

| | |
|-----------------------------|----|
| Petrol engines | 28 |
| Diesel engines | 34 |
| Fuel system | 38 |
| Exhaust system | 39 |
| Engine/gearbox combinations | 40 |

Power transmission

| | |
|---|----|
| Overview | 42 |
| 5th generation Haldex coupling | 44 |
| Freewheel mode of dual clutch gearbox OD9 / OCW | 50 |
| Selector mechanism | 51 |

Suspension system

| | |
|-------------------------------|----|
| Overall concept | 52 |
| Steering system | 54 |
| Brake system | 55 |
| adaptive cruise control (ACC) | 56 |
| Wheels and tyres | 57 |

Electrical system

| | |
|---|----|
| Audi drive select | 58 |
| Installation locations of control units | 60 |
| Topology | 62 |

Air conditioning

| | |
|----------------------------|----|
| Introduction | 64 |
| Heater and air conditioner | 66 |
| Auxiliary heater | 67 |
| Connected components | 70 |

Infotainment

| | |
|---|----|
| Overview of versions | 72 |
| Modular Infotainment Platform (MIP) | 74 |
| Audi connect (market dependent) | 79 |
| Components in the Audi A3 '13 | 80 |
| Universal Mobile Phone Preparation – Audi phone box | 86 |

Service

| | |
|--------------------------------------|----|
| Special tools and workshop equipment | 88 |
| Inspection and maintenance | 90 |
| Self Study Programmes | 91 |

Introduction

In brief

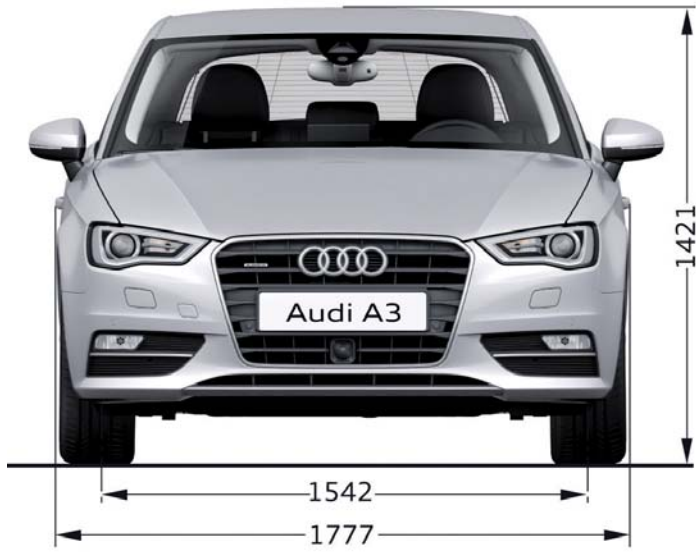

609_035



609_036

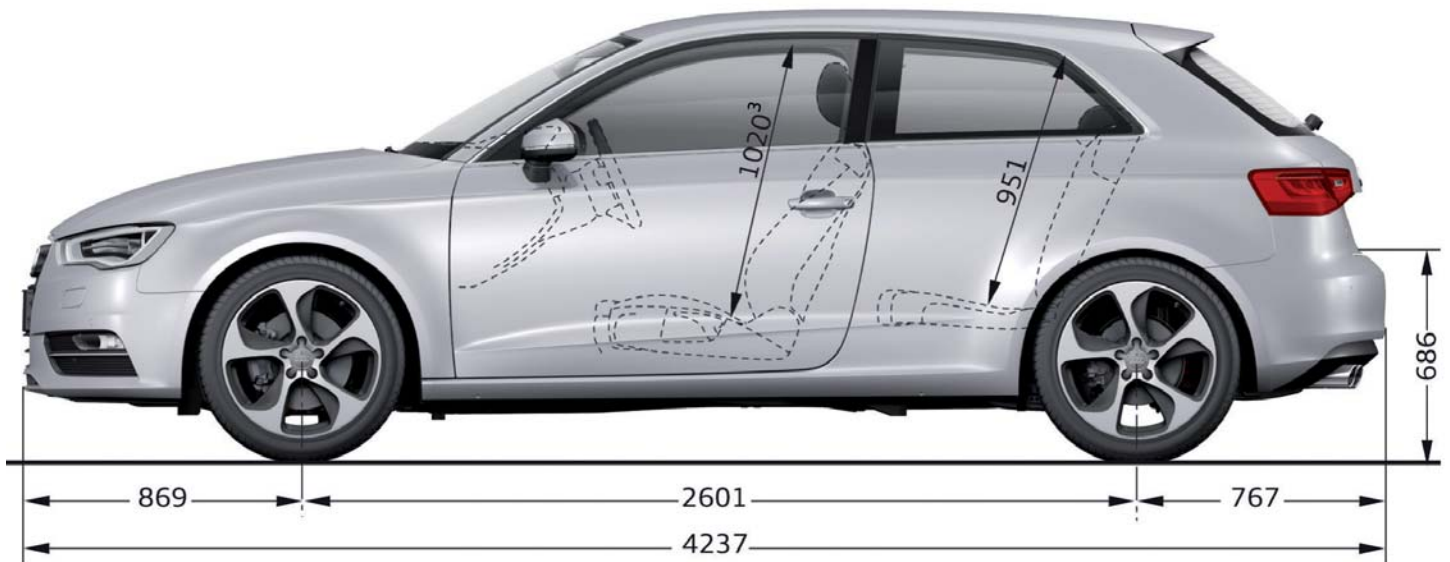

609_037

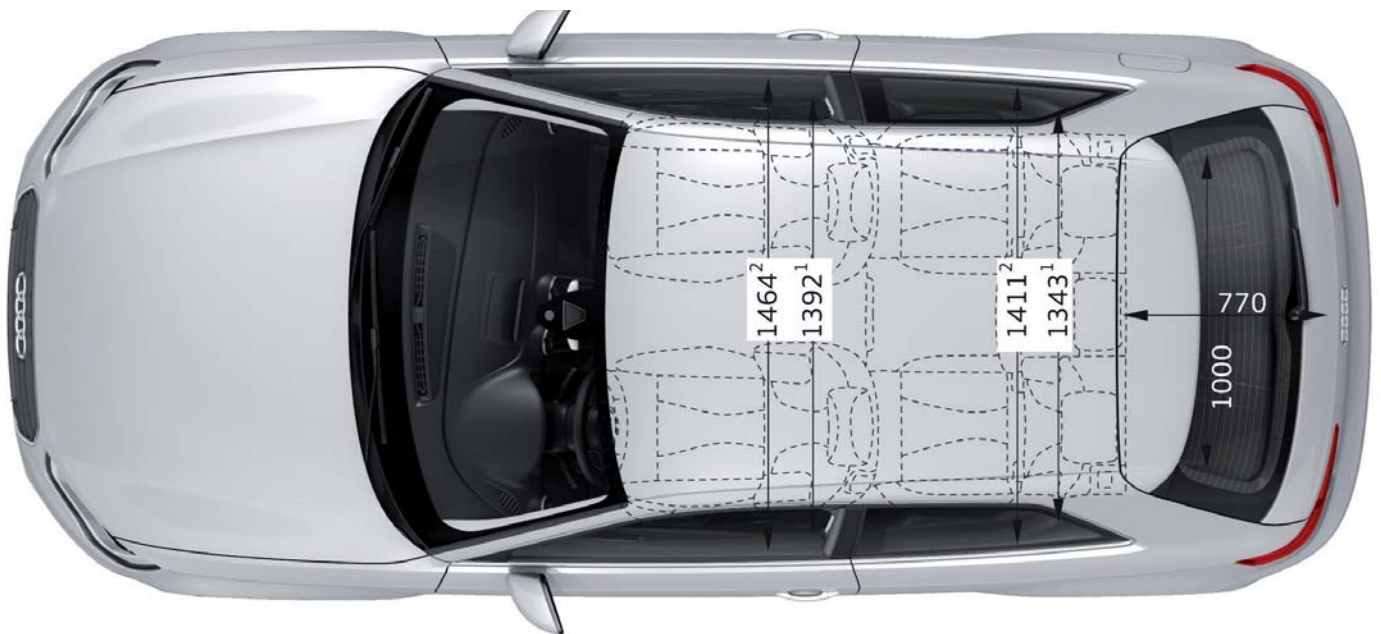

609_038

| | | | |
|--|--------------------|------------------------------------|------------------------|
| Length in mm | 4237 | Cabin width, front in mm | 1464 |
| Width in mm | 1777 | Cabin width, rear in mm | 1411 |
| Height in mm | 1421 | Headroom, front in mm | 1020 |
| Track width, front in mm | 1542 | Headroom, rear in mm | 951 |
| Track width, rear in mm | 1514 | Through-loading width in mm | 1000 |
| Wheelbase in mm | 2601 | Load sill height in mm | 686 |
| Trailer load in kg with brake at a gradient of 8 % | 1800 ⁴⁾ | Boot capacity in l | 365/1100 ⁵⁾ |
| Kerb weight in kg | 1280 ⁴⁾ | Tank capacity in l | 50 |
| Max. gross weight in kg | 1840 | Drag coefficient in c_w | 0,31 |

¹⁾ Width of shoulder room

²⁾ Width of elbow room

³⁾ Maximum headroom

⁴⁾ with a 2.0l TDI engine developing 110 kW at 320 Nm

⁵⁾ with the seat back folded down and loaded up to roof level

All dimensions are given in millimetres and refer to the unladen weight of the vehicle.

Body

Body structure

A major factor in achieving the ambitious body weight targets for the Audi A3 '13 was the systematic application and development of lightweight design. Thanks to Audi ultra-lightweight design technology, the Audi A3 '13 is much lighter than its predecessor.

The following factors were taken into account:

- ▶ Passive safety
- ▶ Torsional rigidity
- ▶ Vibration comfort
- ▶ Acoustics

Ultra-high-strength hot-formed components

Ultra-high-strength hot-formed components are used for the first time in the Audi A3 '13, increasing the stability of the occupant cell without adding weight. The occupant cell is the survival space for the vehicle's occupants.

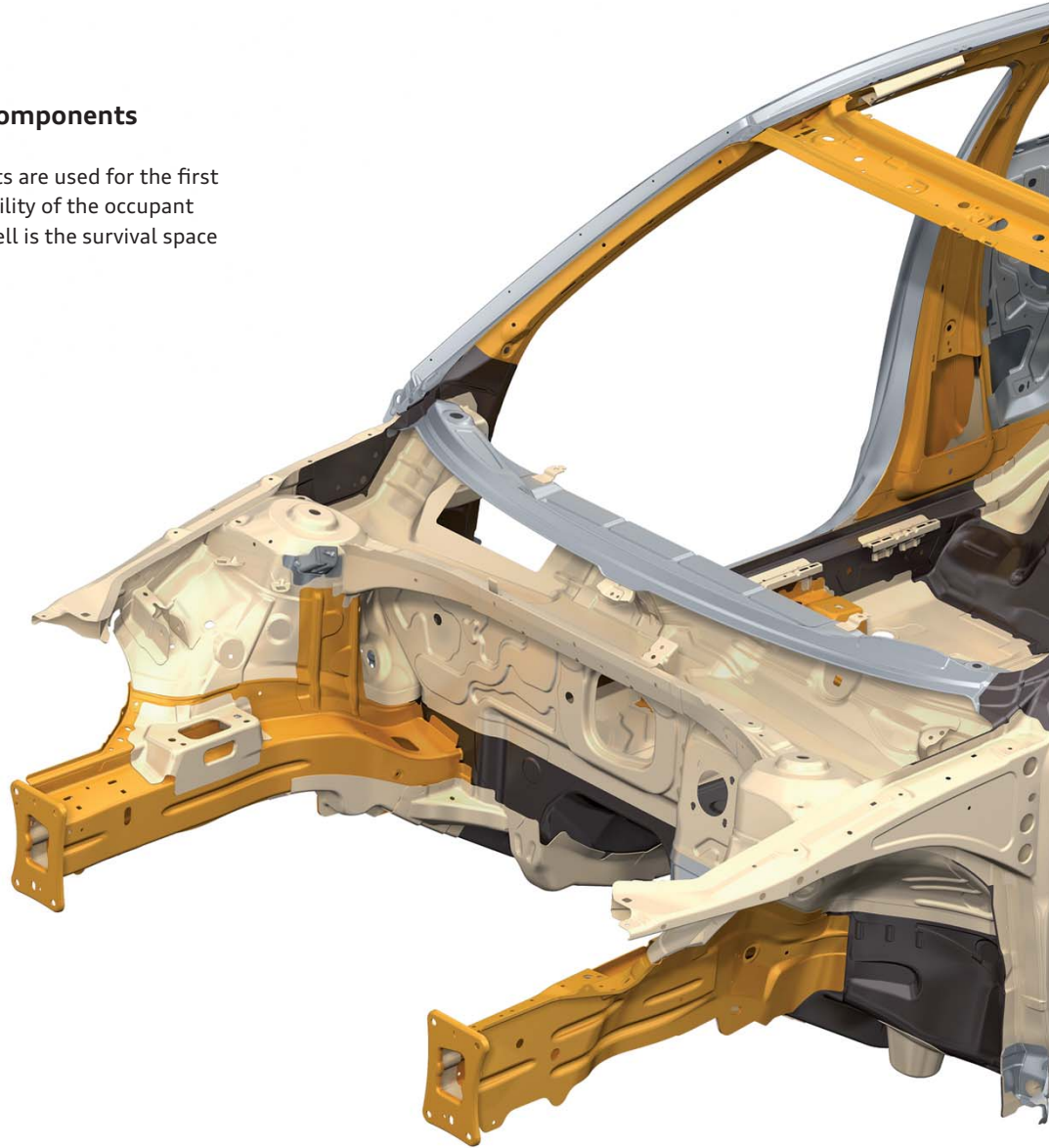

Ultra-high-strength hot-formed components are installed in the following areas:

- | | | | |
|---|------------------------------|---|------------------------------|
| ① | Side member 2, left/right | ⑥ | Heel section reinforcement |
| ② | Upper footwell cross member | ⑦ | Cross member |
| ③ | Lower footwell cross member | ⑧ | Top left/right A post |
| ④ | Inside left/right sill panel | ⑨ | Rear side member, left/right |
| ⑤ | Tunnel | ⑩ | Inside left/right B post |

Key:

Ultra-high-strength steels (hot-formed) 12 %

High-strength steel 13 %

Modern high-strength steels 19 %

Soft steel 56 %

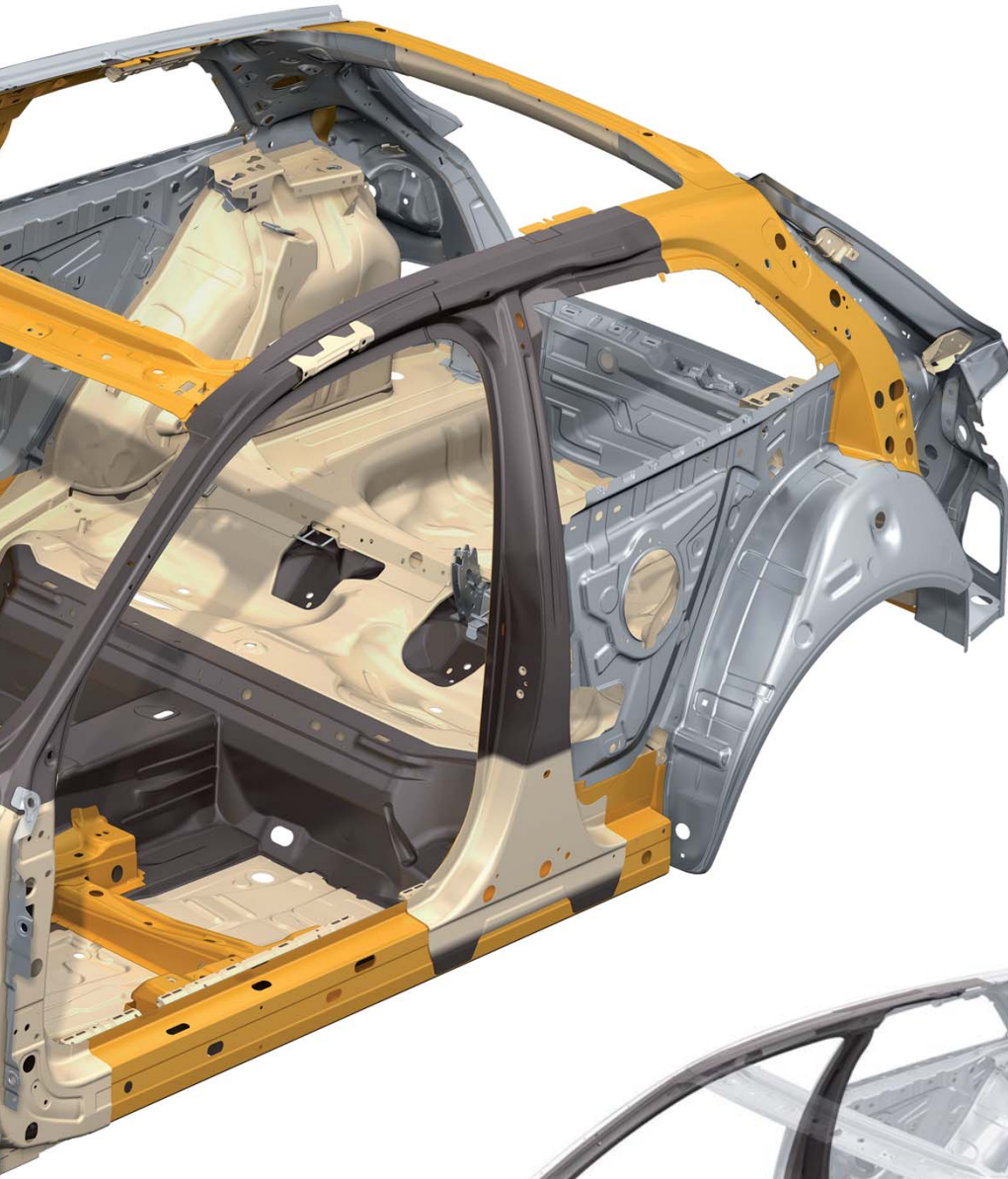

609_052



609_055

Attachments

The attachments, specifically the doors and the rear hatch, are of lightweight steel construction.





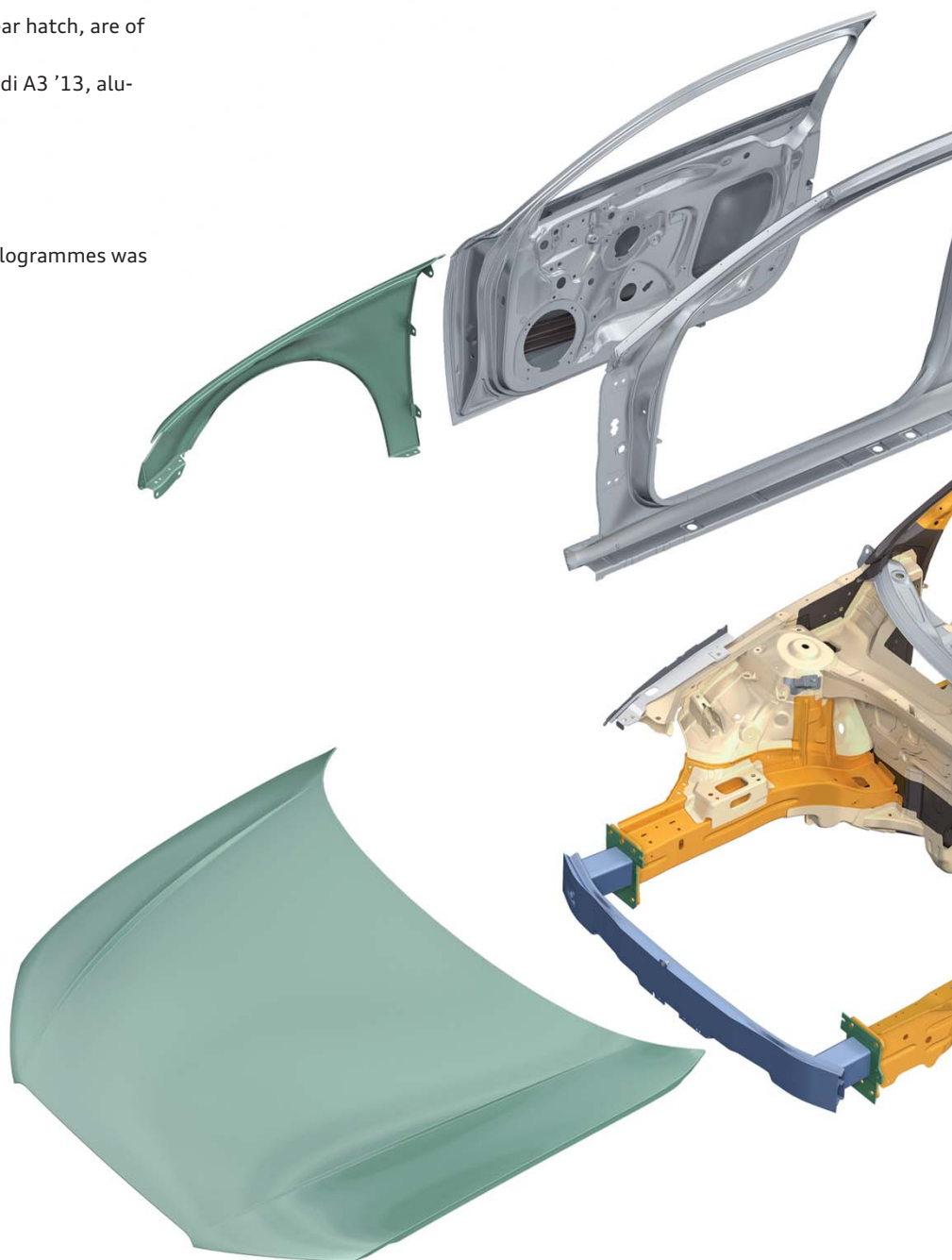

For the first time in the third generation of the Audi A3 '13, aluminium is used in the following components:

- ▶ Bonnet
- ▶ Wings

A further reduction in weight of more than nine kilogrammes was achieved by using aluminium.



Key:

| | |
|--|--|
|  | Ultra-high-strength steel (hot-formed) |
|  | Modern high-strength steel |
|  | High-strength steel |
|  | Mild steel |
|  | Sheet aluminium |
|  | Aluminium section |

Joining techniques

Resistance spot welding is the predominant joining method in the body structure of the Audi A3 '13. Its acknowledged advantages are those of affordability, durability and process reliability. Resistance spot welding is combined with a high-strength bonding process in the body zones where stringent requirements apply to vibration comfort and passive safety. This produces a strong surface attachment to the structural flanges, increasing structural rigidity and significantly reducing the load on highly stressed spot welds.

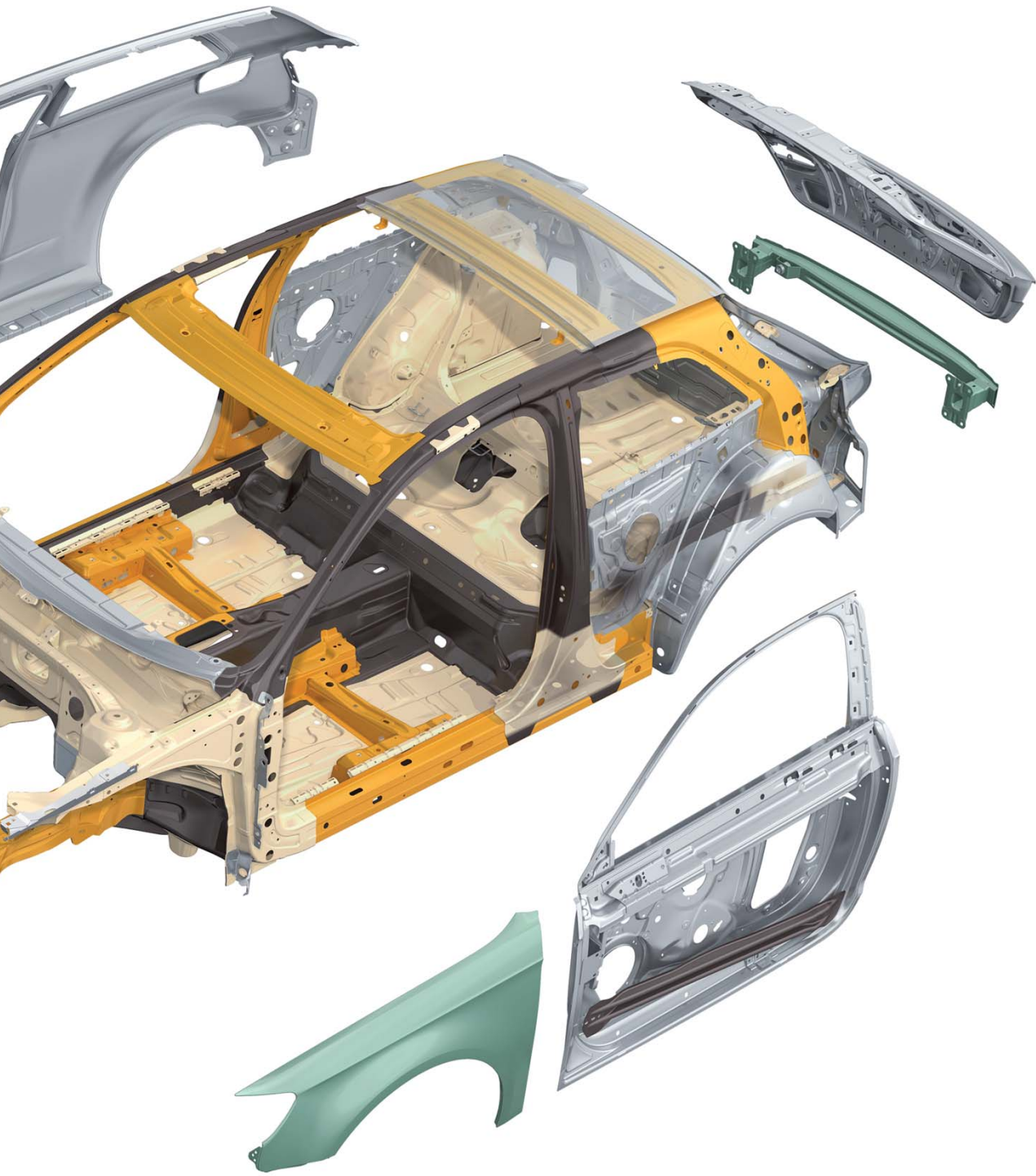

609_053

Resistance spot welding:
76.3 %

Plasmatron brazing:
8 %

Bonding:
14.6 %

MAG welding:
3.1 %

Plasmatron brazing is used to meet the exacting visual specifications in other outer body areas, producing a seamless joint between the roof and sidewall frame and in the water channel between the rear hatch and sidewall.

609_054

Panorama tilt sunroof

The panorama slide/tilt sunroof is an equipment option for the Audi A3 '13. It is fitted as an externally guided roof system. This roof is a further development of the well-known Audi A1 panorama sunroof and has been adapted to the Audi A3 '13 with respect to its design and size.

The roof opening is larger than that of an internally guided sunroof and creates a particularly airy and spacious interior feel for the occupants.



609_069

Thermal insulation

The glass roof panel is tinted and provides additional thermal insulation. Thermal insulation is provided by the following reflective components:

- ▶ 99 % UV radiation reflection
- ▶ 92 % heat radiation reflection
- ▶ 90 % light radiation reflection

The panorama slide/tilt sunroof module meets the statutory requirements for anti-pinch protection.



609_083

Roof installation

The Audi A3 '13 panorama slide/tilt sunroof is glued into the roof opening and thus is a major factor contributing to body rigidity.

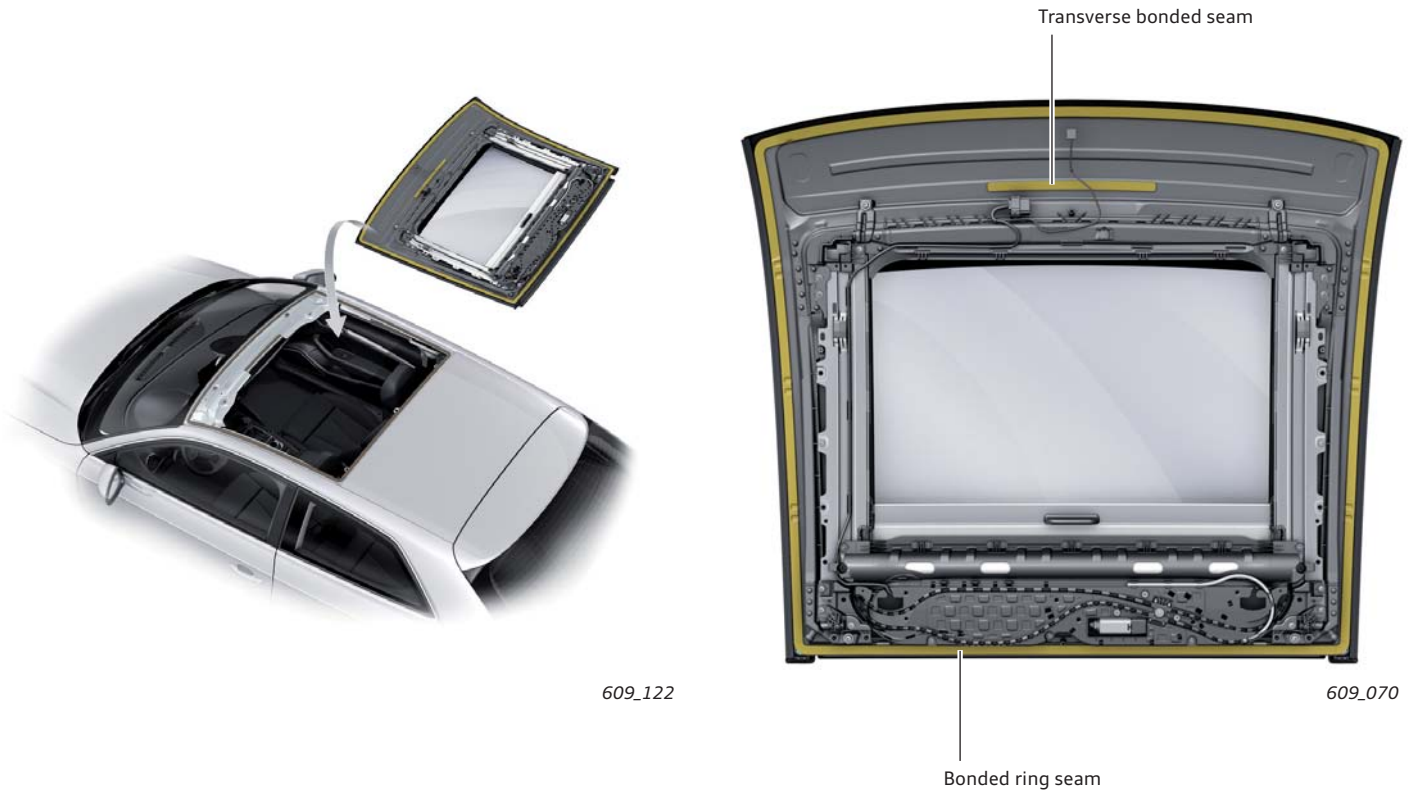

Component overview

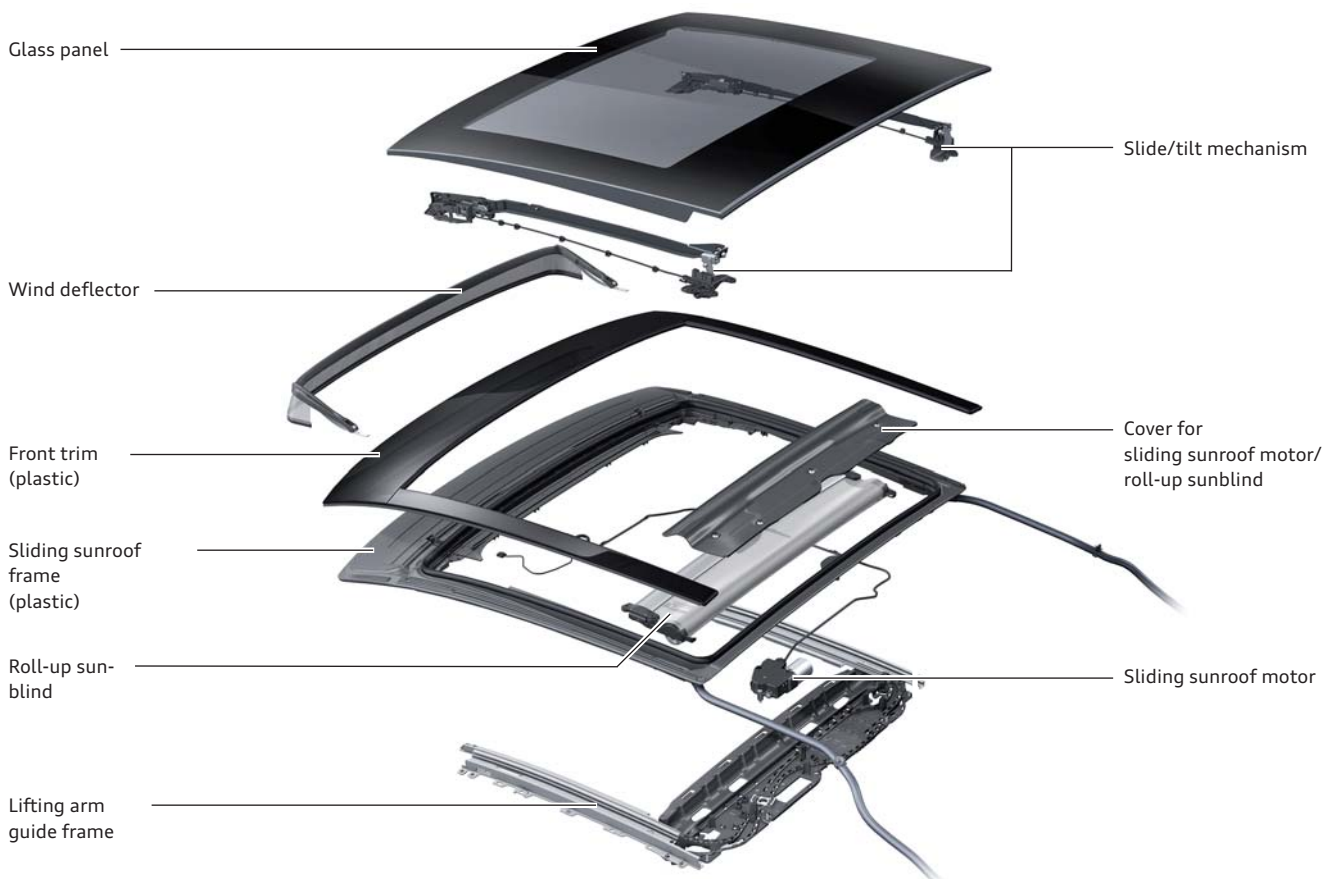

609_071

Bumper system

Front bumper

Characteristic elements of the vehicle's front end are the one-piece bumper cover and striking single-frame radiator grille. Large air intakes in the front hint at the power of the engines.

In addition to existing APS and ACC sensors in the bumper system, the Audi A3 '13 is equipped with further pedestrian protection sensors. These sensors are located on the back of the front bumper cover.

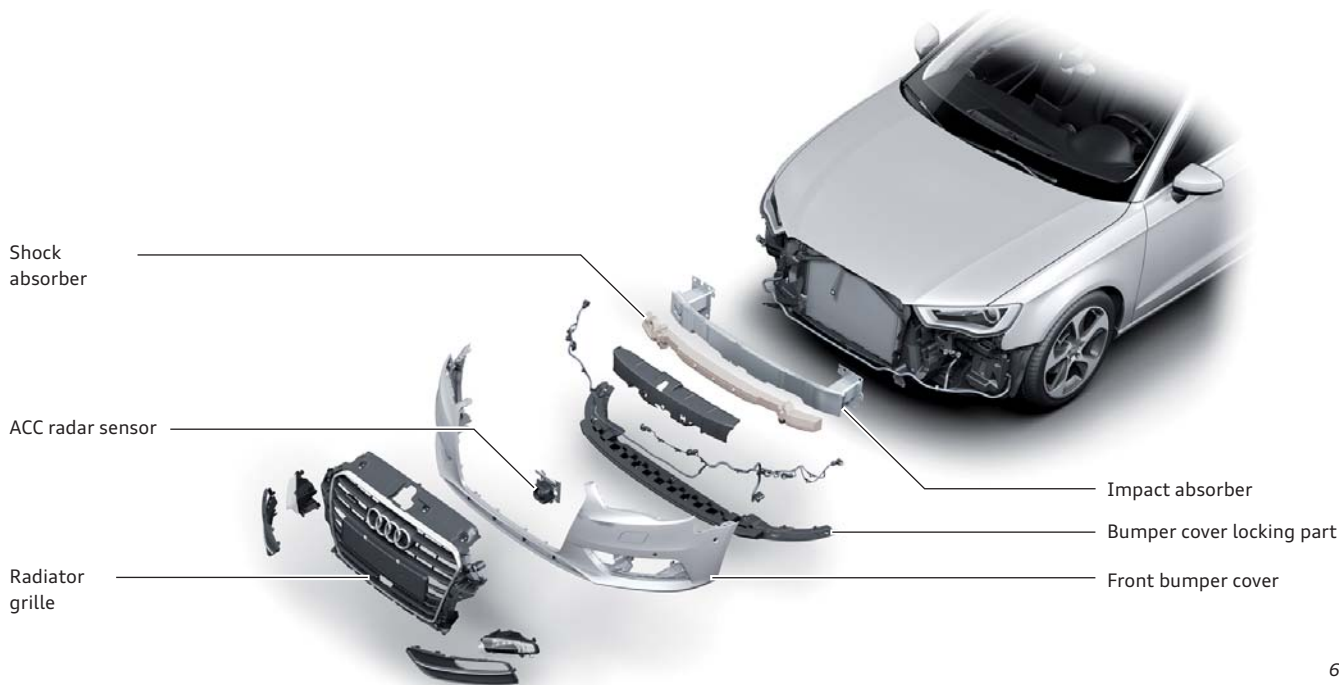

609_072

Rear bumper

The rear bumper comprises a cover with a welded locking part and a spoiler with integrated diffusor for the exhaust tail pipes. The sensors for the optional Audi side assist system are mounted to the locking part. The rear sensors for the optional parking aid or park assist function are mounted to the spoiler cover.

The bumper is attached to the rear end of the body using the locking part. The pre-assembled guiding parts are attached flush with the body side sections.

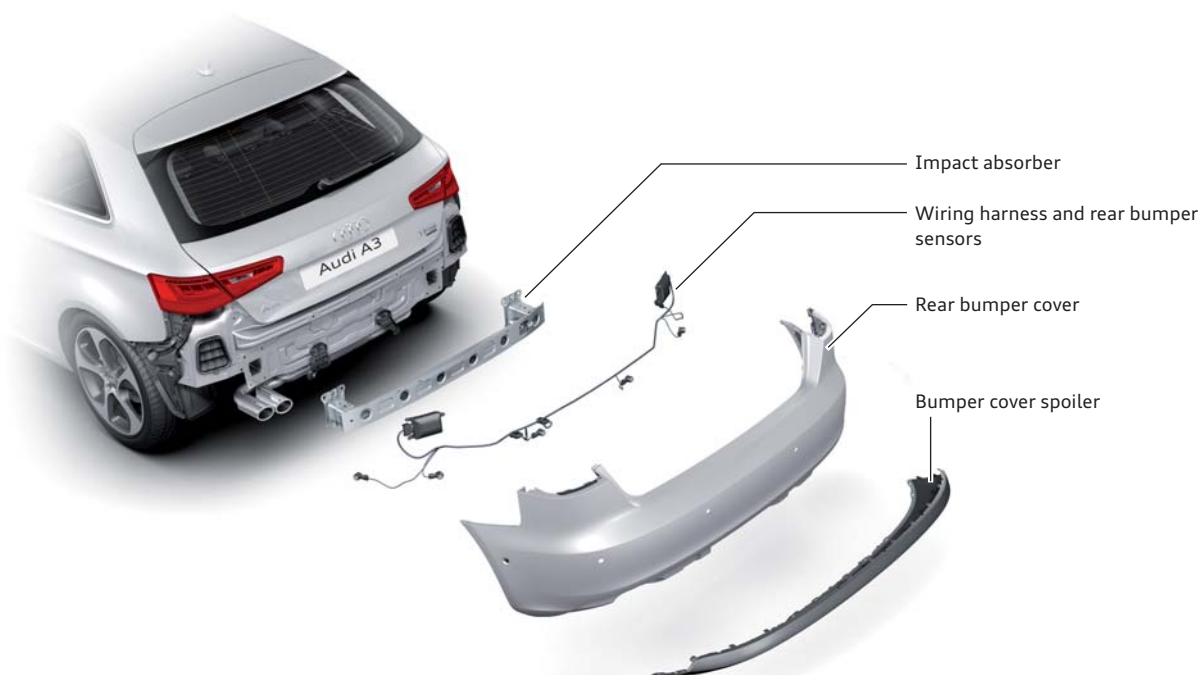

609_073

Underbody

The Audi A3 '13 has an acoustically and aerodynamically highly effective underbody designed to withstand mechanical and thermal stresses. In addition to aerodynamics, attention was paid to sound absorption, body protection and thermal engine management during the development phase.

The result is improved airflow around the engine and gearbox capsule, the cross-members and the wheel arches, thus allowing a low drag coefficient (c_w) of 0.31 to be achieved.

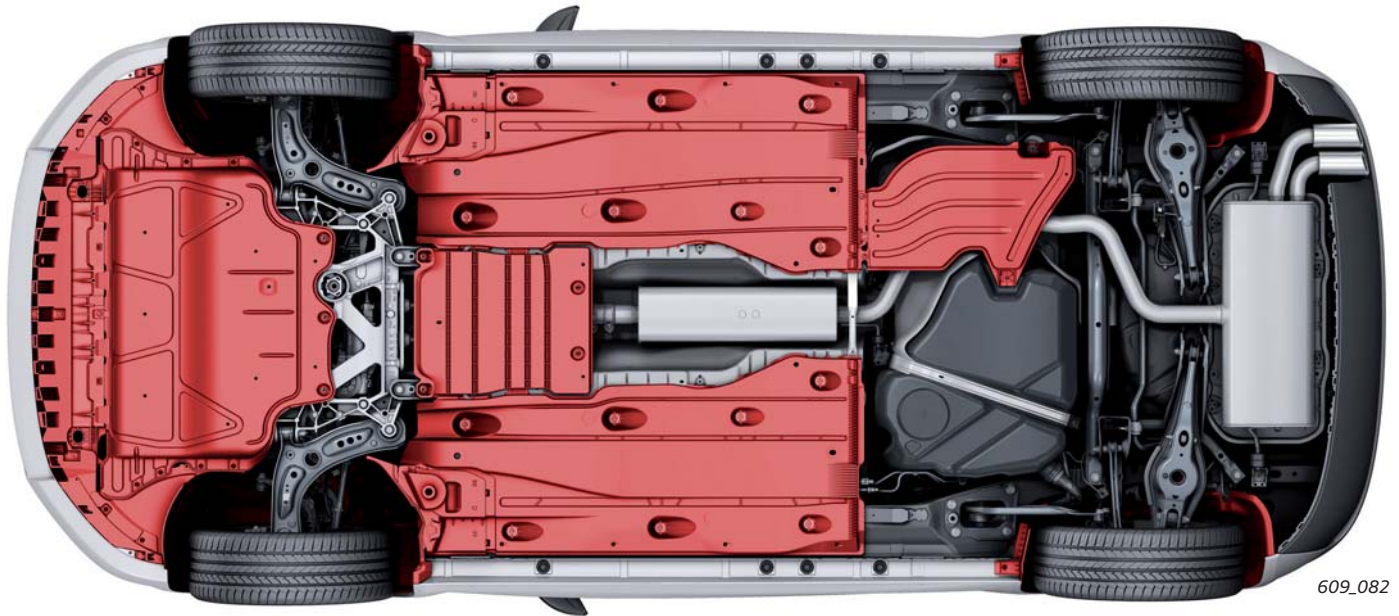

Tow bar

As an option, the Audi A3 '13 can be ordered with a tow bar including a removable ball rod. The ball rod is located beneath the load floor cover in the vehicle's luggage compartment.

It is possible to attach and remove the ball rod by hand, but this must be done with care in order to ensure that it is locked securely.



Passive safety

Components

The passive occupant and pedestrian protection system in the Audi A3 '13 comprises the following components and systems:

- ▶ Airbag control unit
- ▶ Driver and passenger airbags
- ▶ Front side airbags
- ▶ Head airbags
- ▶ Driver side knee airbag
- ▶ Front airbag crash sensor
- ▶ Crash sensors for side impact detection in the doors
- ▶ Crash sensors for side impact detection in the C posts
- ▶ Crash sensors for pedestrian protection in the front bumper cover
- ▶ Front inertia reel seat belts with electric and pyrotechnic belt tensioners
- ▶ Seat belt warning for all seats
- ▶ Seat belt switches on all seats in the seat belt buckles
- ▶ Seat occupancy sensor in front passenger seat
- ▶ Pedestrian protection trigger



609_007

Additional equipment

The vehicle can optionally be equipped with a keyswitch for deactivating the front passenger airbag with accompanying warning lamp.

Due to the different statutory provisions and requirements for car makers in the various markets, equipment specifications can vary.

Key to figure on page 15:

- E24 Seat belt switch, driver side
- E25 Seat belt switch, passenger side
- E224 Airbag disabling switch, passenger side (optional)
- E258 Rear seat belt switch, driver side
- E259 Rear seat belt switch, passenger side
- E609 Rear central seat belt switch

- G128 Passenger side seat occupancy sensor
- G179 Side airbag crash sensor, driver side
- G180 Side airbag crash sensor, passenger side
- G256 Rear side airbag crash sensor, driver side (C post)
- G257 Rear side airbag crash sensor, driver side (C post)
- G283 Front airbag crash sensor, driver side (front end)
- G570 Pedestrian protection crash sensor, driver side
- G571 Pedestrian protection crash sensor, passenger side
- G598 Pedestrian protection trigger 1
- G599 Pedestrian protection trigger 2
- G693 Pedestrian protection crash sensor, centre

- J234 Airbag control unit
- J285 Control unit in instrument cluster
- J533 Data bus diagnostic interface (gateway)
- J854 Front left seat belt tensioner control unit (optional)
- J855 Front right seat belt tensioner control unit (optional)

- K19 Seat belt reminder warning lamp
- K75 Airbag warning lamp
- K145 Passenger airbag off warning lamp (PASSENGER AIRBAG OFF) (optional)

- N95 Driver side airbag igniter
- N131 Passenger side airbag igniter 1
- N153 Seat belt tensioner igniter 1, driver side
- N154 Seat belt tensioner igniter 1, passenger side
- N199 Side airbag igniter, driver side
- N200 Side airbag igniter, passenger side
- N251 Head airbag igniter, driver side
- N252 Head airbag igniter, passenger side
- N295 Knee airbag igniter, driver side

- T16 16 pin connector, diagnostic port



Note

The diagrams in the chapter entitled "Passive occupant safety" are schematic diagrams and serve to provide a better understanding.

System overview

The system overview shows by way of example the equipment options available for a German-spec model.

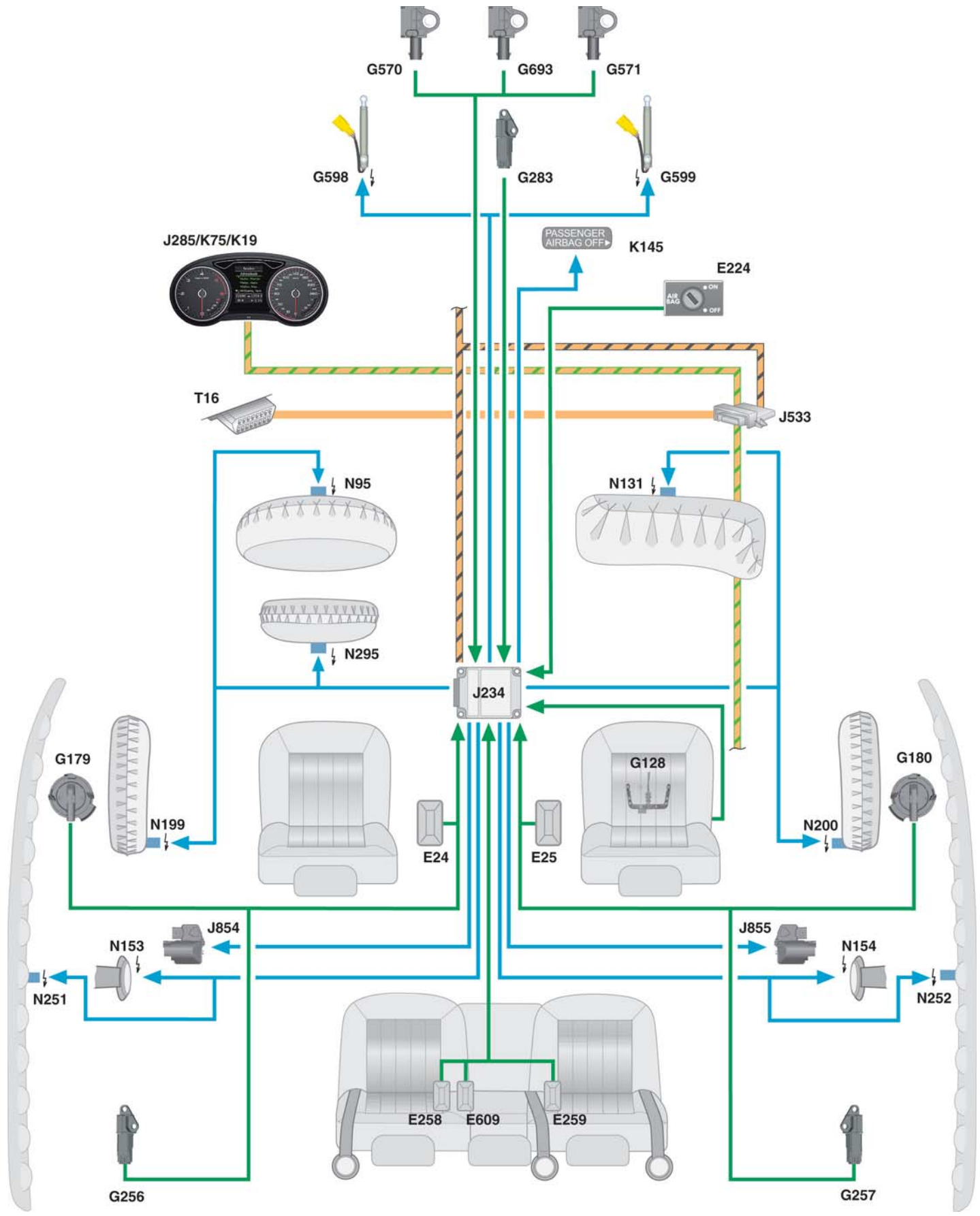

Key:

- Powertrain CAN bus
- Diagnostics CAN bus
- Input signal
- Output signal
- Convenience CAN bus

609_001

Airbag systems

Passenger airbag

The Audi A3 '13 is equipped with a single-stage hybrid gas generator on the passenger side. For the first time in an Audi, a canister-type gas generator is used on the passenger side in place of a tubular gas generator.

The advantage of this is that the passenger airbag module of the Audi A3 '13 is about 25% lighter than in the Audi A3 '04.



609_012

The passenger side airbag igniter N131 ignited by the airbag control unit J234 (igniting resistance wire including a small amount of pyrotechnics) punctures rupture disc 1. This ignites the priming charge, which in turn ignites the actual propellant charge. Rupture disc 2 ruptures due to the rise in pressure. The mixture of cold gas and reaction gas - resulting from combustion of the pyrotechnics - escapes through the metal filter and flows through the outlets and into the folded airbag.

The airbag inflates inside the dash panel. If the pressure on the perforation in the dash panel is high enough, the perforation breaks open and the airbag is fully inflated inside the occupant cell.

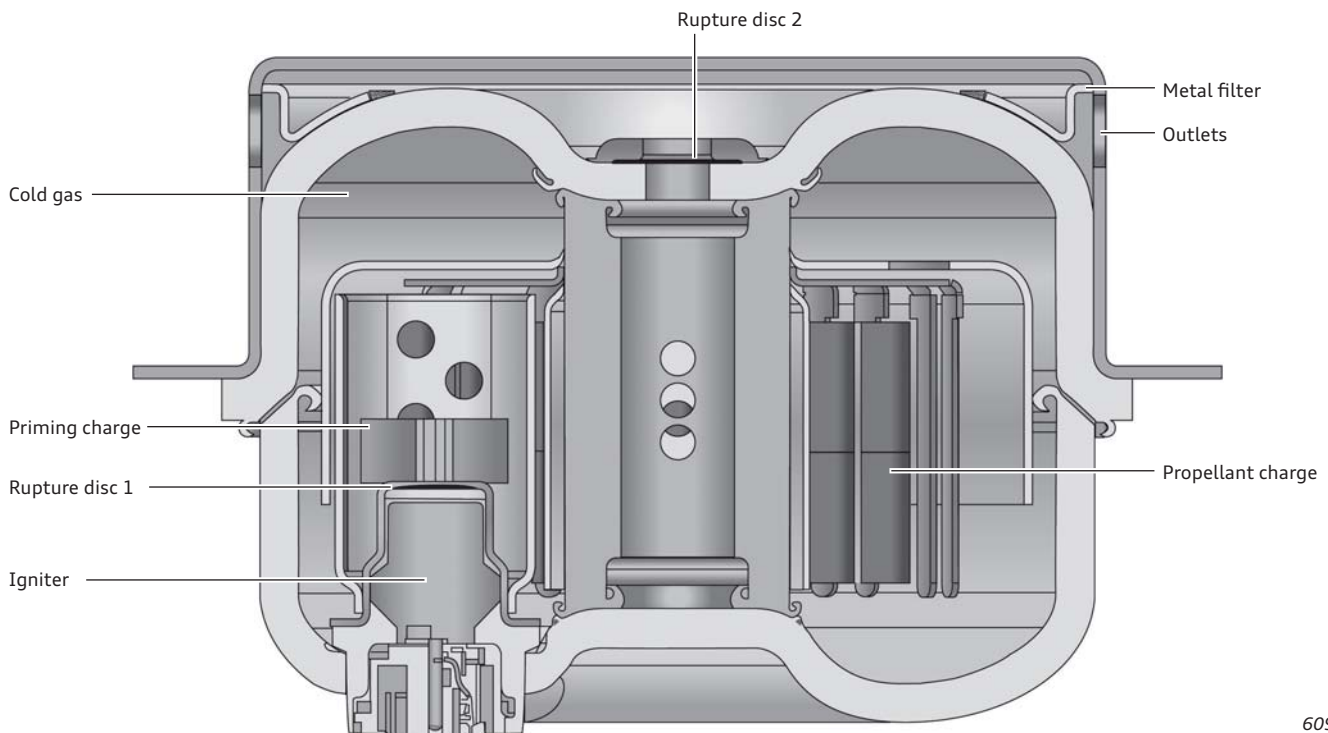

609_013

New connector generation

In comparison to its predecessor, the additional ground line on the passenger airbag has been integrated into the passenger airbag connector in the Audi A3 '13. This ground line is designed to protect the passenger airbag pyrotechnics against electrostatic discharge.

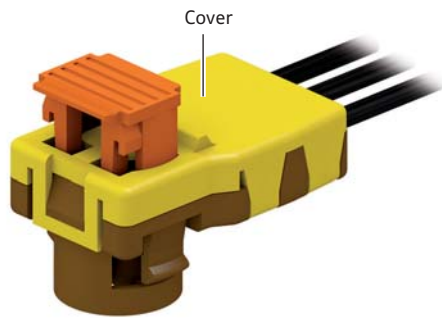

After contacting the connector, the ground cable connects the gas generator housing to the body in an electrically conductive manner. The airbag connector is encoded mechanically.

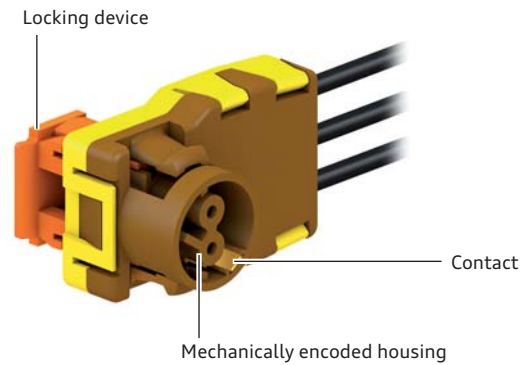

Driver side knee airbag

609_014

The Audi A3 '13 is equipped with a knee airbag on the driver's side. The knee airbag is designed as a tubular-type cold gas generator.

The knee airbag is connected to the body in an electrically conductive manner by the bracket. To ensure electrical conductivity, there must be sufficient contact between the mount and the body. Please pay attention to the workshop manual.

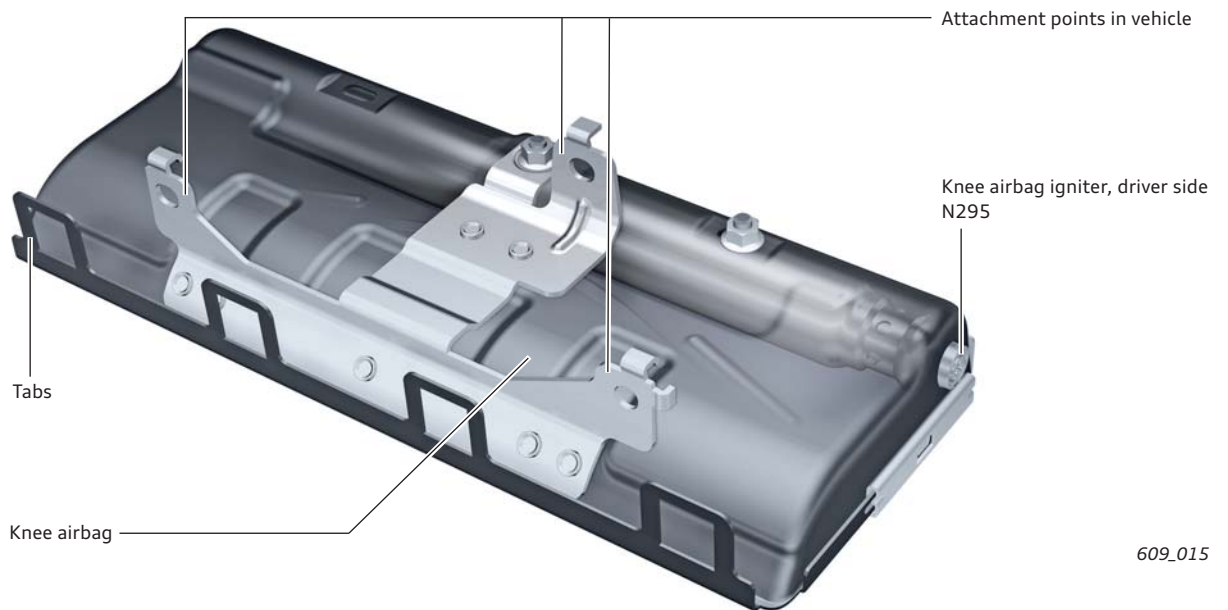

609_015

The knee airbag igniter, driver side N295 activated by the airbag control unit J234 (igniting resistance wire including a small amount of pyrotechnics) punctures rupture disc 1. The cold gas compressed under high pressure in the gas cylinder escapes through the outlets and into the folded airbag. The knee airbag, which has a capacity of approx. 14 litres, inflates.

It ensures that the knee and the lower leg of the driver are better protected.

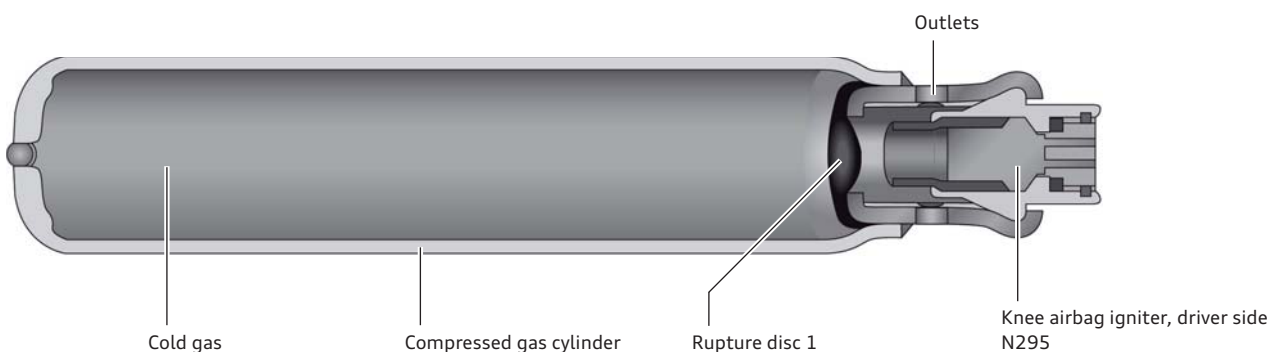

609_016

Seat occupancy sensor

The Audi A3 '13 is equipped with a passenger side seat occupancy sensor G128. The passenger side seat occupancy sensor is a component of the seat belt reminder system. The sensor consists of two plastic films which are bonded together. Electrically conductive circuit tracks and contact faces are printed onto the insides of the films. The plastic films in the area of the contact sensors are kept apart using spacer film and are not bonded. Consequently, there is no contact between the contact films in the area of the contact sensors in the rest state. If weight is now placed on the seat occupancy sensor, the films in the proximity of the contact sensors are pressed together, reducing the total resistance to less than 120 ohms. At least one contact sensor on each side must be compressed in order that the seat position sensor detects occupancy. If the passenger seat is unoccupied, the seat occupancy sensor has a high resistance (approx. 470 ohms).

For the first time in an Audi, the seat occupancy sensor of the Audi A3 '13 is mounted directly on the seat shell and NOT on the seat cushion. The sensor is fitted with round and oblong-hole clips for exact positioning. The clips are premounted to the sensor. In addition, the sensor is marked TOP and FRONT.

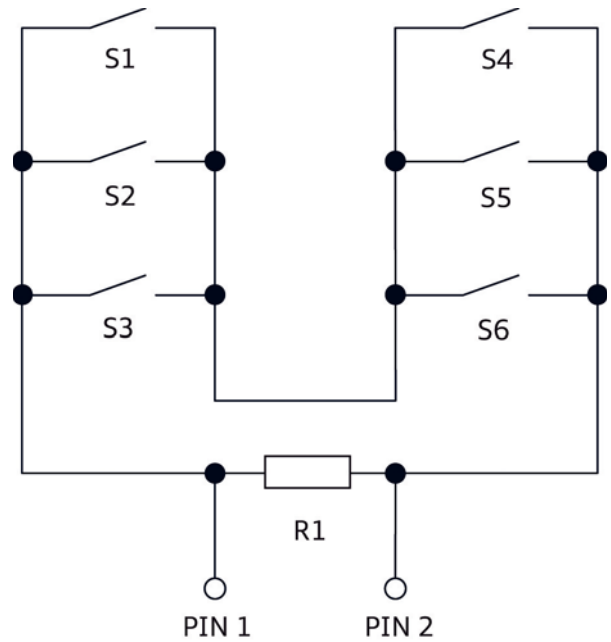

609_022

Passenger side seat occupancy sensor G128

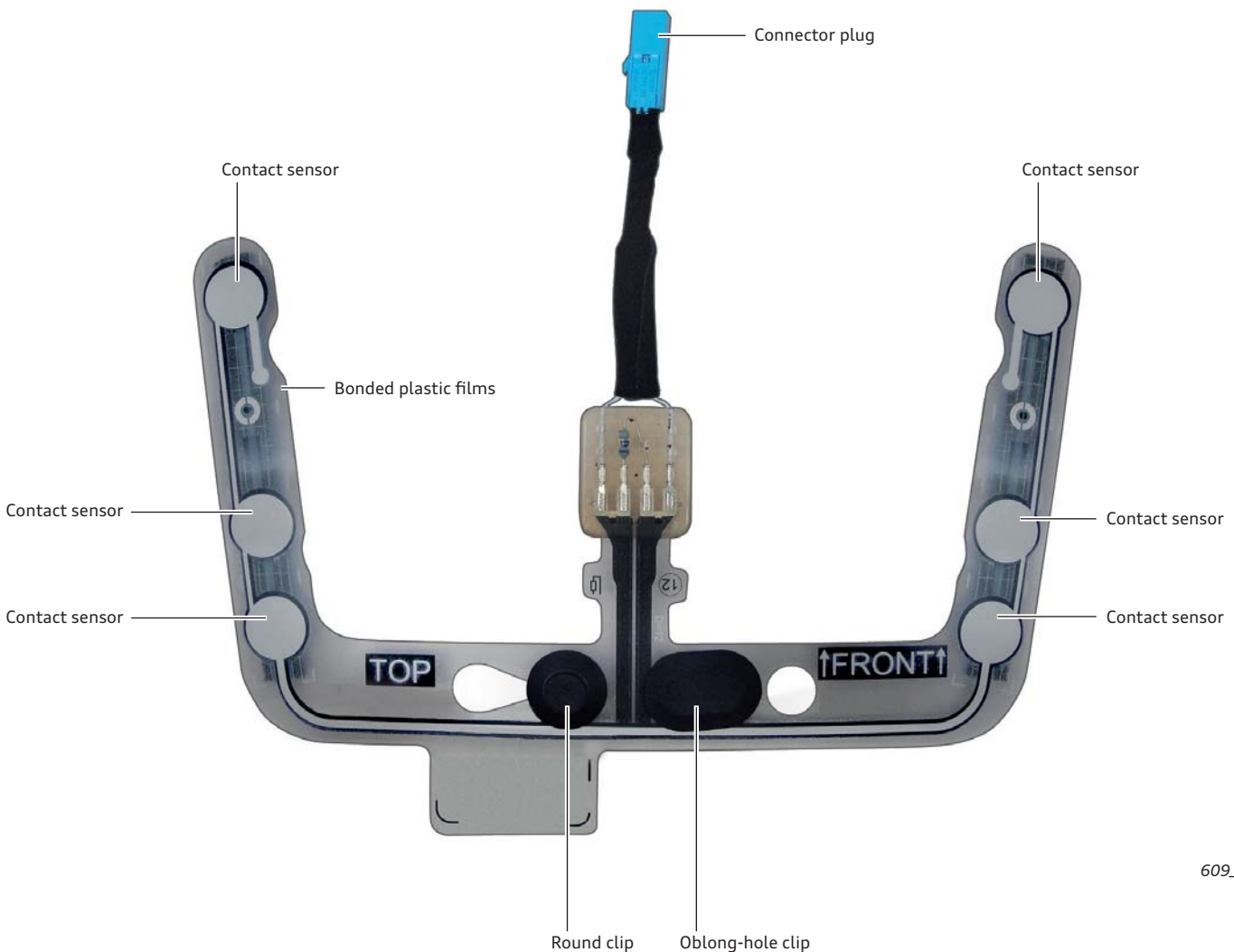

609_018

Front seat belt tensioner

In combination with pre sense basic front automatic seat belt retractors, the Audi A3 '13 is equipped with reversible seat belt tensioners with electric motors in addition to the pyrotechnic belt tensioners. The reversible seat belt tensioners together with the front left and right seat belt tensioner control units (J854 and J855 respectively) are connected to the airbag control unit J234 as LIN control units.

When Audi pre sense basic detects specific driving situations, signals are sent to the data bus. The airbag control unit evaluates the signals and, if necessary, instructs the seat belt tensioner control unit to partially or fully tension the seat belts via an electric motor. For further information on Audi pre sense, refer to the chapter on Active safety, page 22 ff.

The automatic seat belt retractors use rack-type pyrotechnic belt tensioners.

If an automatic seat belt retractor with seat belt tensioner control unit is replaced, the basic setting procedure must be performed using the "Guided Fault Finding" function.

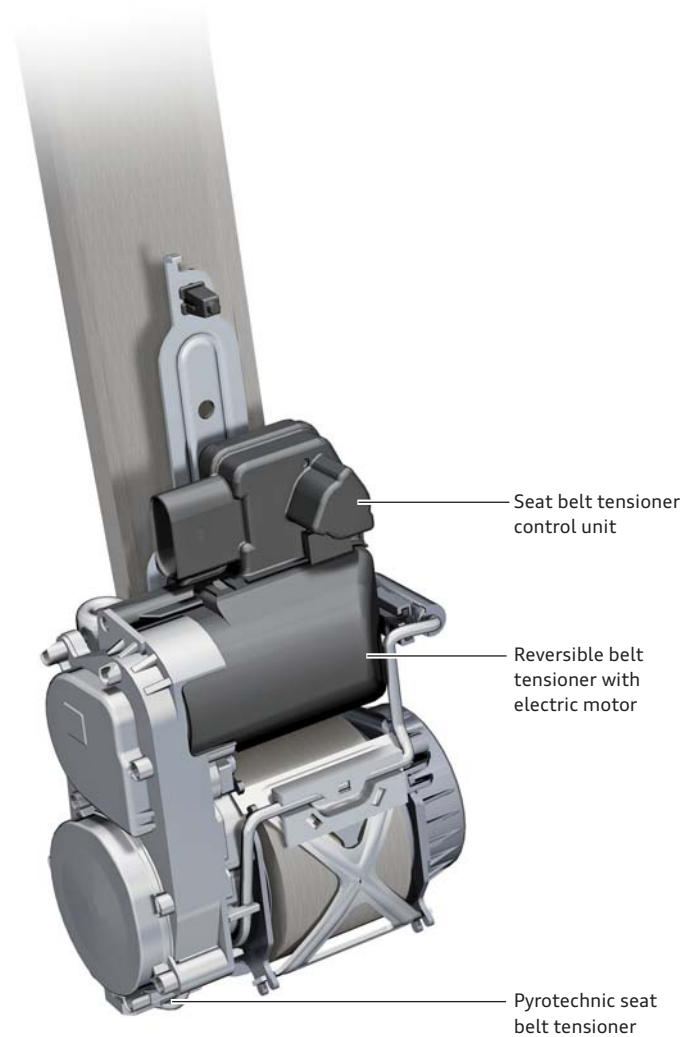

609_080

Side airbag crash sensor

The side airbag crash sensors for the driver and passenger sides (G179 and G180) are capacitive pressure sensors. The pressure sensors have a new mounting concept and are **no longer** bolted.

The pressure sensors are inserted into the sheet metal of the driver and passenger door and fastened by twisting.

The seals seal off the system.

The view shows the crash sensor locked in place, but without the door panel.

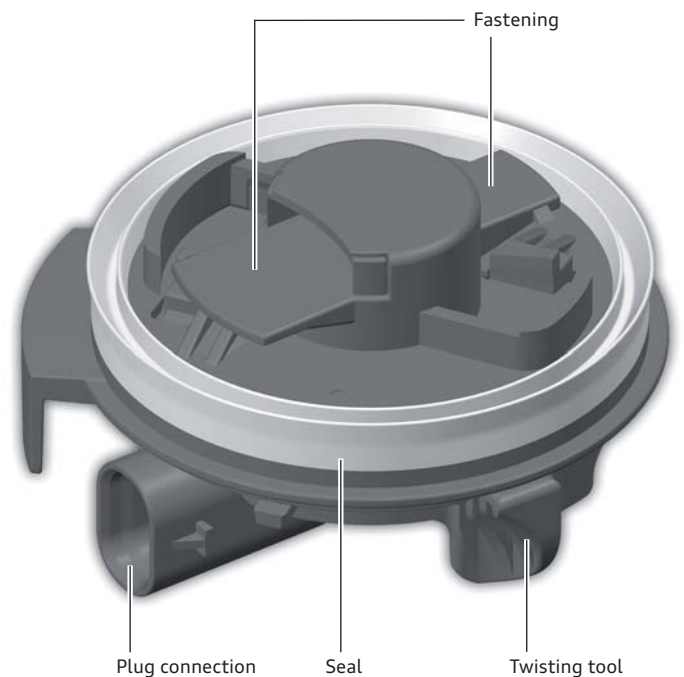

609_081



Reference

For information on removing and installing the side airbag crash sensor, refer to the workshop manual.

Pedestrian protection

The Audi A3 '13 is equipped with a system which can reduce the extent of head injuries sustainable by pedestrians in the event of a head-on collision with an Audi A3 '13. For this purpose, the bonnet is "displaced" to increase the distance between the bonnet and components in the engine bay and thereby create an additional "crumple zone".

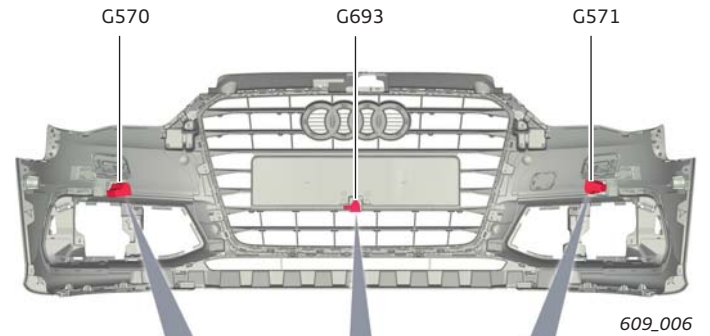

Pedestrian protection crash sensor

To enable the Audi A3 '13 to detect a collision with a pedestrian, it is equipped with additional crash sensors:

- ▶ Driver side pedestrian protection crash sensor G570
- ▶ Passenger side pedestrian protection crash sensor G571
- ▶ Pedestrian protection crash sensor G693

These sensors are located on the back of the bumper cover. They are acceleration sensors.



Pedestrian protection trigger

The pedestrian protection system triggers are pyrotechnic components comprising an igniter unit and cylinders with pistons.

- ▶ Pedestrian protection trigger 1 G598
- ▶ Pedestrian protection trigger 2 G599

The same safety precautions apply as for airbags.

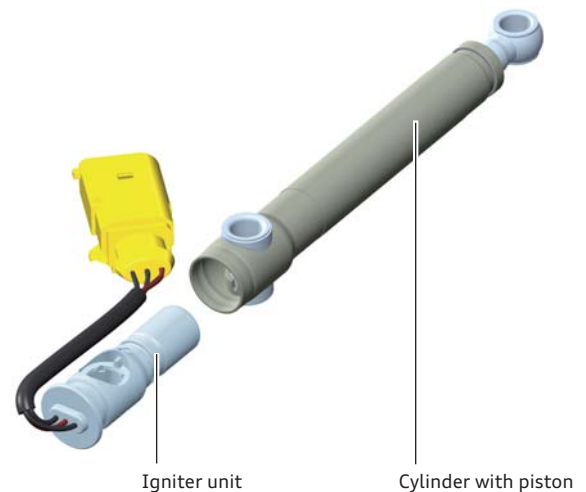

Note

The system is non-reversible and must be repaired immediately. After the bonnet has been displaced back, the vehicle can still be driven to the nearest authorised repairer.

Function

In the event of a collision with a pedestrian at a speed of between approximately 25 and 55 kph, the airbag control unit J234 activates both pedestrian protection triggers (G598 and G599). The propellant charges are ignited at the same time, and the developing gas pressure displaces the pistons in the pedestrian protection cylinders.

The pistons are attached excentrically to the hooks, with the result that the longitudinal movement of the piston causes the hooks to rotate. The hooks rotate away from the counter bearings and the pistons extend.

Due to the kinematics of the bonnet hinges, the bonnet is displaced approximately 20 mm backwards and approximately 52 mm upwards at the back.

Bonnet hinge in rest position

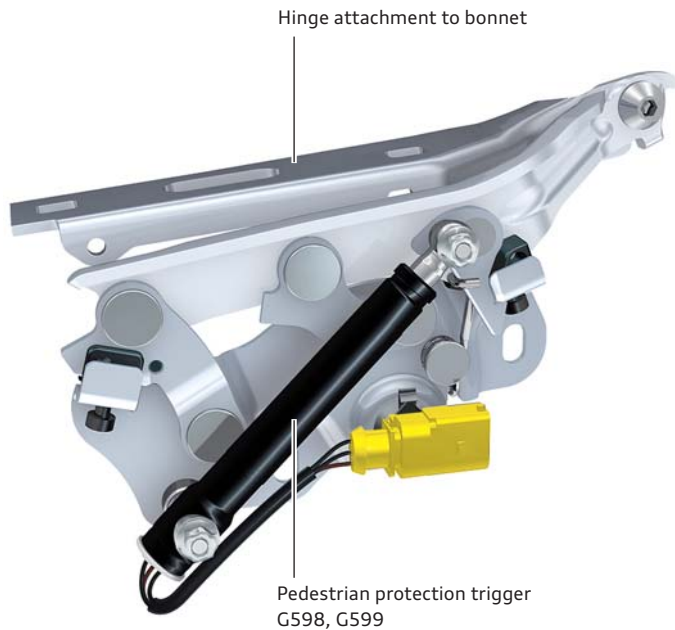

609_008

Bonnet hinge deployed

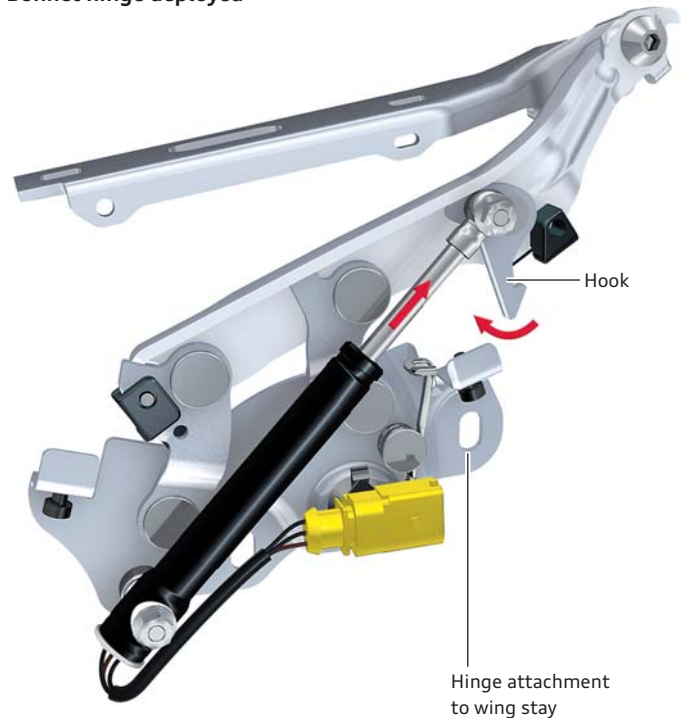

609_009

Fault message

Faults in the system are indicated by the airbag warning lamp K75 in the instrument cluster (control unit in instrument cluster J285). In addition, the instrument cluster displays a warning triangle and the following text for six seconds after ignition "on": „*Safety system: malfunction! See owner's manual!*“.

The airbag control unit J234 continuously monitors the pedestrian protection system for proper functioning. Irregularities in the system are registered as diagnostic trouble codes in the airbag control unit.

For information about repair operations on the pedestrian protection triggers, refer to "External body repairs" in ELSA. The repair operations on the pedestrian protection crash sensors are described in "Internal body repairs".

A deployed system is indicated in the instrument cluster in much the same way as a fault.

Open deployed bonnet

The bonnet can only be opened in the deployed state if it has been displaced back.

This is done as follows: on the left and right hand sides of the vehicle, push down on the bonnet with both hands at the hinge while simultaneously pushing forward (as shown) until the bonnet locks in its original position.



609_010



Reference

Please follow the instructions given in the workshop manual.

Active safety

Audi pre sense

Audi pre sense is able to detect critical driving situations, and initiates measures to prepare the vehicle and occupants for a potential impending collision.

This is made possible by networking the various in-vehicle systems. The systems send data continuously to the data bus. Other control units are able to evaluate this information and take appropriate action.

Audi pre sense basic

Longitudinal dynamics function

If the vehicle is moving forward at a speed of over 30 kph (reverse is not engaged) and the driver executes a "hazard braking manoeuvre" (whereby the brake pressure must reach a defined level), the reversible seat belt tensioners are partially tensioned under electrical power.

Customers can order the Audi A3 '13 with the optional Audi pre sense basic and/or Audi pre sense front system. Please note that Audi pre sense cannot prevent collisions. It serves only to assist the driver and reduce the severity of the collision.



609_075

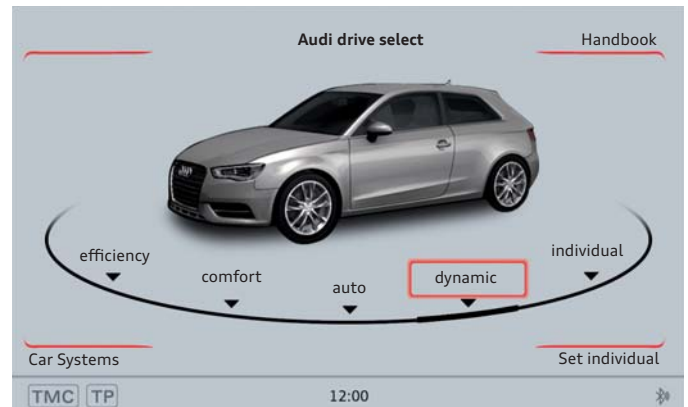

609_076

Emergency braking function

During an "emergency braking" manoeuvre (brake pressure is at or exceeds a defined value for a defined period of time), the reversible seat belt tensioners are fully tensioned electrically. The airbag control unit J234 evaluates the signals which the ABS control unit J104 transfers to the data bus.

It instructs the seat belt tensioner control units, J854 and J855, to fully tension the seat belts, both electrically and reversibly. Depending on the situation, the ABS control unit J104 can instruct the hazard warning flashers to be activated.

Transverse dynamics function

If the Audi A3 '13 oversteers or understeers, the ESP system tries to stabilise the vehicle. If the vehicle becomes unstable because certain physical limits have been exceeded, the airbag control unit J234 initiates a partial tensioning of the electrically reversible seat belt tensioners.

If the vehicle can no longer be stabilised, the electrically reversible seat belt tensioners are fully tensioned.

At the same time, the side windows and the tilt/slide sunroof (if fitted) begin to close.

- ▶ If ESP is set to "Sport" or "Off" or if Audi drive select is set to "dynamic", the seat belts are **not** partially tensioned.
- ▶ If ESP is set to "Sport" mode or "Off", the seat belts are fully tensioned only if the driver actively applies the brakes.

Audi pre sense front

The optional Audi pre sense front system also comes with Audi adaptive cruise control (ACC). The ACC radar sensor which is integrated in the ACC control unit J428 monitors the traffic ahead of the vehicle and continuously measures the distance to a vehicle driving ahead.

The ACC control unit evaluates the data and transfers relevant signals to the data bus. Other bus users receive the signals. The ACC control unit utilises these signals to initiate different actions via the control unit in the instrument cluster and the ESP control unit, if necessary.

Audi pre sense front is active even if the ACC system is not activated. Audi pre sense front has the following functions:

- A** Driver information when following a vehicle ahead at a critical distance in certain situations.
- B** In the event of an impending collision with a moving or stopped vehicle, the driver is warned and assistance is provided by automatic braking or by increasing the braking force applied by the driver, thereby gaining reaction time and reducing speed.
- C** Full deceleration is provided in the event of an impending collision with a moving, stopped or stationary vehicle at a speed of less than 30 kph.

Crash function in the low speed range

If the airbag control unit J234 detects a head-on collision with low vehicle deceleration (no airbag deployment), it decides whether or not to fully tension the seat belts based on a situation-specific control unit algorithm.

It does not take any other precautions, such as turning on the hazard warning flashers, or closing a window or sliding sunroof.

System characteristics of Audi pre sense basic:

- ▶ If a seat belt is not being worn or if the passenger airbag is set to "Off", the reversible seat belt tensioner is not activated.
- ▶ The belt tensioner control units (J854 and J855 respectively) are connected to the airbag control unit as LIN control units.
- ▶ The forward displacement of the front occupants can be reduced by more than 100 mm by tensioning the seat belts.



609_077

Function A

The driver is warned visually if approaching another vehicle ahead and subsequently when following this vehicle at a critical distance and at a synchronised speed.

The critical distance is defined as the distance at which a collision is likely to occur in the event of sudden heavy braking of a vehicle driving ahead, even if the driver of the following vehicle reacts quickly.

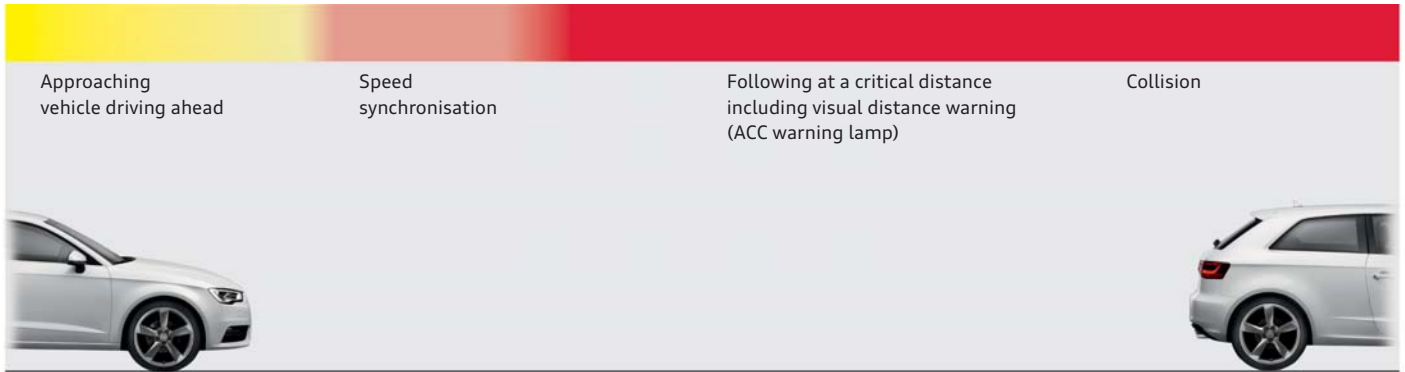

609_061

Function B

When the vehicle approaches a moving vehicle, the control unit in the instrument cluster J285 warns the driver visually and audibly if certain defined limits are exceeded. These warnings are issued within a certain period of time prior to the last braking opportunity for collision avoidance before the actual collision.

The timing of warnings depends on the driver's degree of activity. Depending on steering, pedal and turn signal inputs, the system classifies the driver as active or inactive and, consequently, as attentive or unattentive. If the driver is attentive, the warning will be issued later than for an unattentive driver.

At the same time, the ABS control unit J104 prefills the brake system and modifies the deployment algorithms for Hydraulic Brake Assist. This means that Hydraulic Brake Assist begins to build up brake pressure even at low brake pedal actuation speeds.

If the driver does not respond to the warnings or, for example, eases off the accelerator, the ABS control unit J104 performs a warning braking application.

The warning braking application is a very brief but easily noticeable braking operation and does not serve to slow the vehicle down. It alerts drivers to the traffic situation and indicates to drivers that they must react immediately in order to avoid an impending collision. Depending on how attentive the system evaluates the driver to be, the warning braking application occurs within a specific period of time ahead of the last opportunity for braking and evasive action in order to avoid a collision.

If the driver still fails to react or eases off the accelerator, the vehicle is braked by partial braking operation I, which applies up to 35 % of maximum braking force.

If the vehicle is fitted with a front camera for driver assistance systems R242 and this camera also detects the obstacle, the braking force is increased to up to 60 % of the maximum by partial braking operation II.

If the driver applies the brakes, a target braking manoeuvre can be performed in all phases described above (prefill brake system, reconfiguration of Hydraulic Brake Assist, driver warning, warning braking application, partial braking operations I and II). During the target braking manoeuvre, the Audi pre sense front system calculates whether the driver is applying sufficient braking force to be able to avoid a collision. If this is not the case, the required brake pressure is increased depending on the situation.

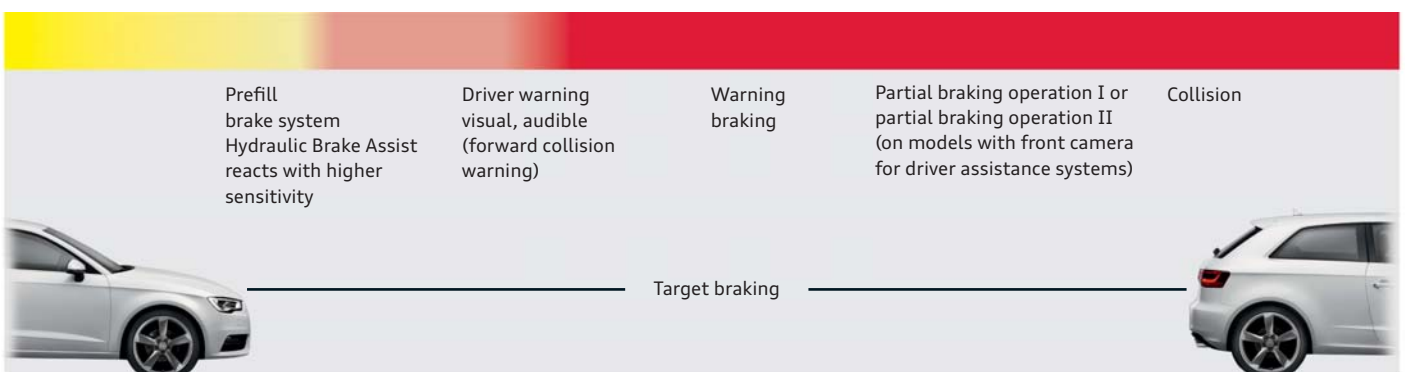

609_063

Function C

Audi pre sense front also includes a function for "full deceleration at speeds from 0 to 30 kph". If the ACC control unit detects an impending collision when the vehicle is travelling at a speed of less than 30 kph, the ABS control unit J104 prefills the brake system.

The deployment algorithms for Hydraulic Brake Assist are adjusted at the same time. Hydraulic Brake Assist thus begins to build up brake pressure even at low brake pedal actuation speeds. If the driver fails to brake or does not apply sufficient braking force in a critical situation, the ABS control unit J104 executes a braking manoeuvre and applies near-maximum braking if necessary.

Before deploying, the vehicle briefly alerts the driver, both audibly and visually, to the fact that it is about to brake independently or provide additional braking. If the Audi A3 '13 has independently braked to a standstill without any driver intervention, three more audible signals are given.

These signals alert drivers to the fact that they must actively take over the vehicle (e.g. by braking). If the driver fails to take over the vehicle, e.g. in a model with automatic transmission, the system will release the brake and the vehicle will begin to roll.



609_064

System characteristics with respect to "full deceleration at speed of less than 30 kph"

- ▶ The driver is not given advance warning.
- ▶ The system reacts to crossing or oncoming vehicles and objects with low radar scatter (e.g. pedestrians).
- ▶ The system reacts to vehicles which are travelling in the same direction, have stopped or are stationary.

Driver prioritisation over system

If the driver clearly takes evasive action, accelerates or brakes during the individual phases of Audi pre sense front (functions A to C), the action momentarily being taken by Audi pre sense front (e.g. partial braking operation I) will be suppressed or cancelled.

If the obstacles is no longer relevant after evasive action has been taken, Audi pre sense front will cease to provide assistance in this case.

Settings and displays

There are two options for deactivating Audi pre sense in the MMI.

- ▶ Option 1: Prewarning off – the audible and visual warnings (distance and forward collision warnings) are deactivated.
- ▶ Option 2: System off – the audible and visual warnings (distance and forward collision warnings), warning braking, partial and target braking and the "full deceleration at speeds of below 30 kph" functions are deactivated. The functions remain deactivated until they are reactivated in the MMI.

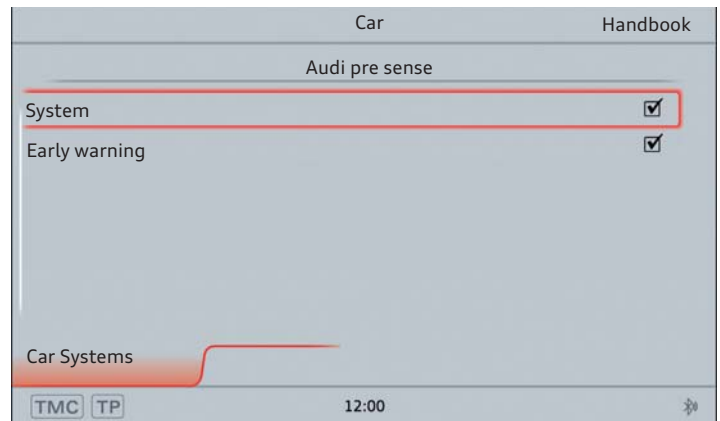

Both versions of Audi pre sense are activated.

609_078

A deactivated Audi pre sense system is temporarily indicated by the following text whenever the control unit in instrument cluster J285 is switched on: "Audi pre sense: off". This alerts the driver (e.g. after stopping for a rest) to the fact that the system is switched off.

If only the prewarning has been deactivated, no text message is displayed in the instrument cluster.

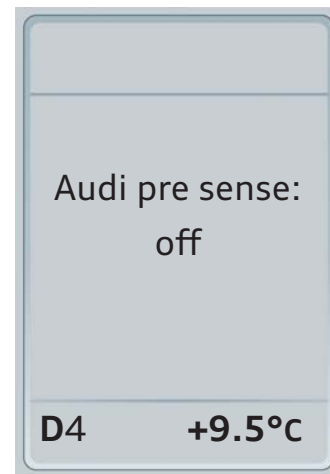

609_079

If ESP (Electronic Stabilisation Program) is set to "Sport" or "Off" with the TCS/ESP button E256, then the audible and visual warnings, the warning braking, the partial and target braking, and the "full deceleration at speeds of below 30 kph" functions of Audi pre sense will also be deactivated.

Audi pre sense remains deactivated until:

- ▶ ESP is reactivated with the TCS/ESP button E256.
- ▶ the ignition is turned off and on again, thereby reactivating ESP.
- ▶ ACC is activated, since this would result in automatic activation of ESP.

If ESP (Electronic Stabilisation Program) is set to "Sport" or "Off" with the TCS/ESP button E256, the following text is temporarily displayed on the control unit in the instrument cluster J285: "Audi pre sense: off".



Reference

For further information on ACC, refer to Self Study Programme 612 "Audi A3 '13 Suspension". For further information on the front camera for driver assistance systems R242, refer to Self Study Programme 611 "Audi A3 '13 Vehicle Electronics and Driver Assistance Systems".

Data bus overview

The overview shows by way of example some of the information which is exchanged via data bus.

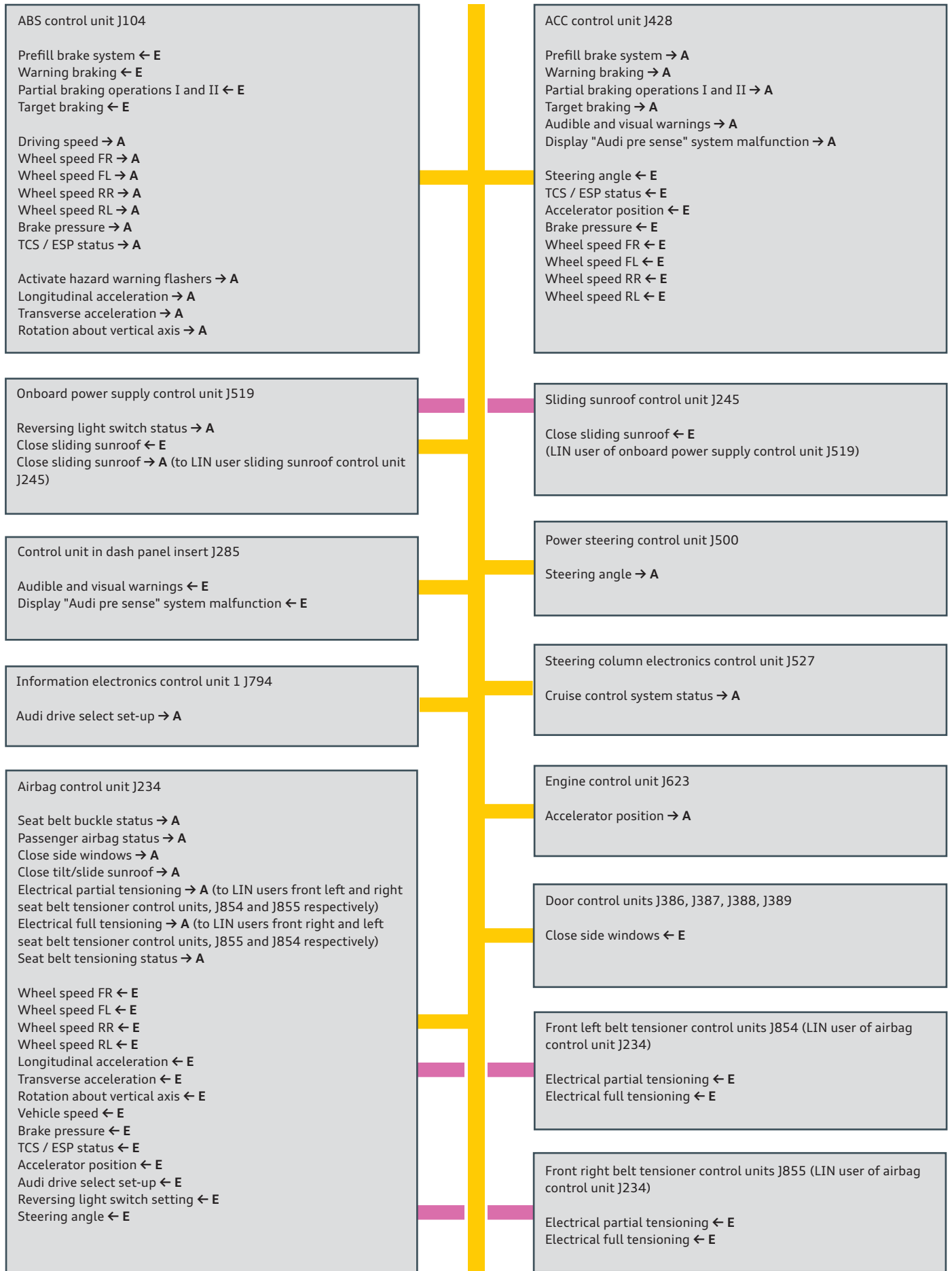

Key:

- Yellow line: Data bus in general
- Pink line: LIN bus

← E Data is received (input)
→ A Data is sent (output)

Engines

Petrol engines

1.4l TFSI engine

Technical features

Exhaust manifold with turbocharger and catalytic converter

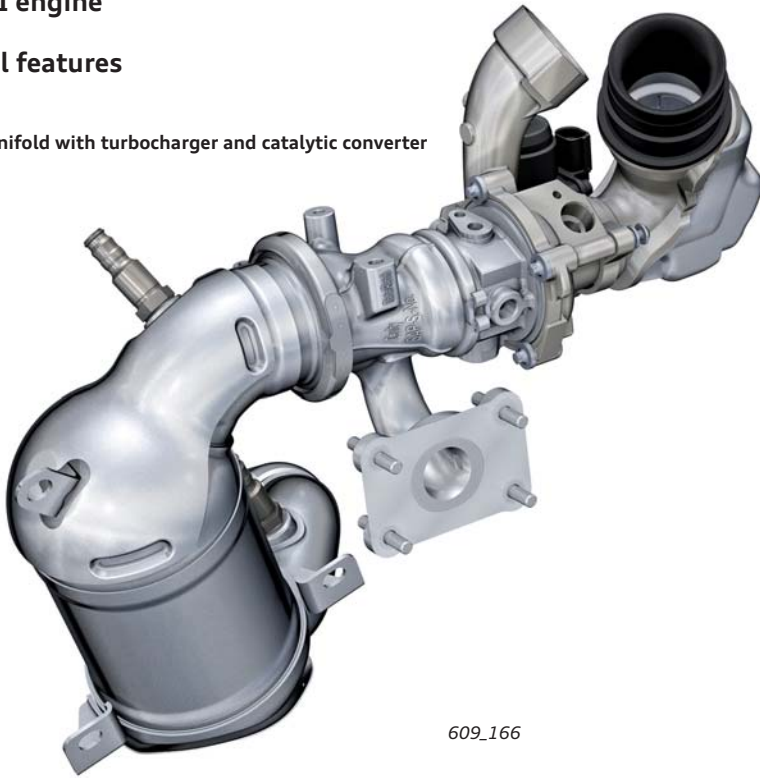

609_166

Auxiliary unit and timing drive



609_170

Oil sump module with auxiliary unit mount

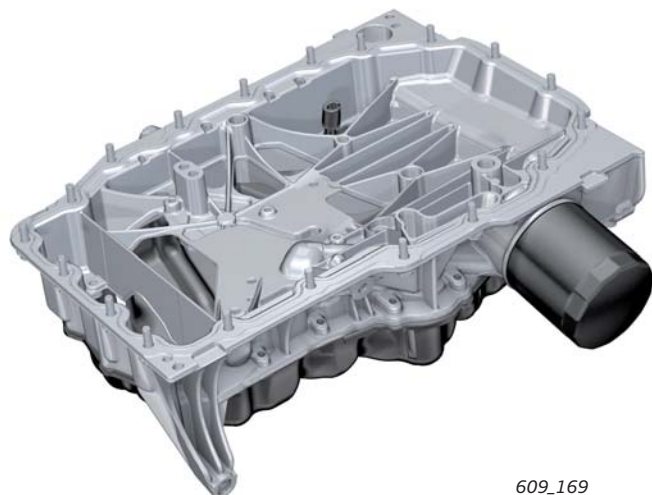

609_169



Cylinder head cover with integrated valvetrain module

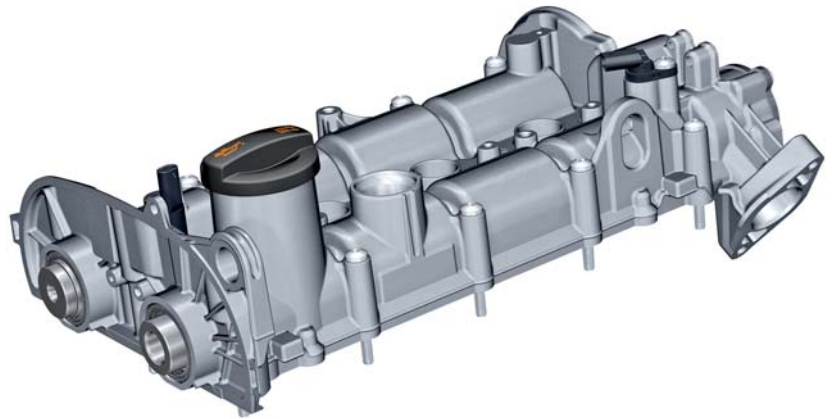

609_167

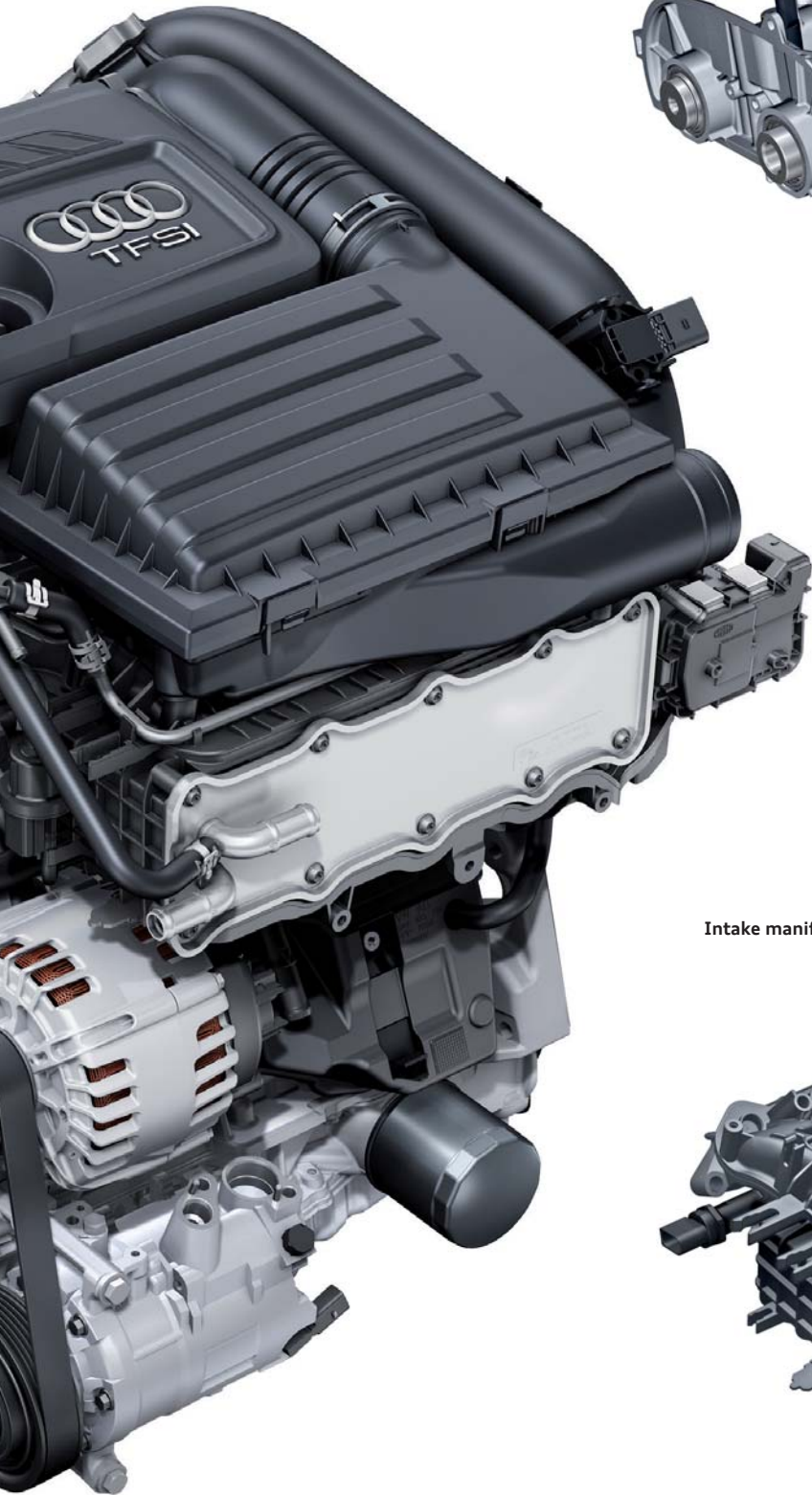

609_155

Intake manifold with integrated charge air cooler

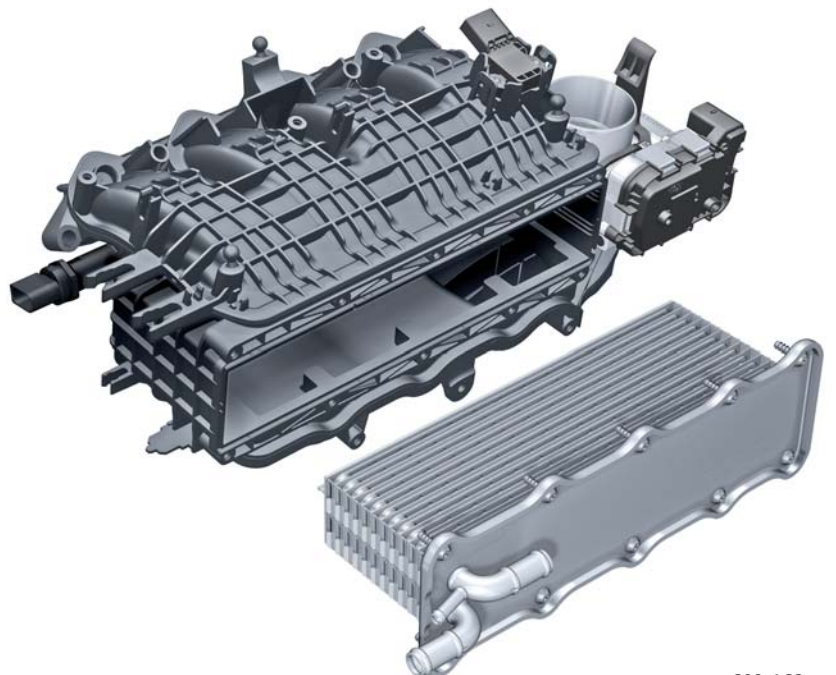

609_168

1.8l TFSI engine

Technical features

Cylinder head with Integrated Exhaust Manifold (IEM)

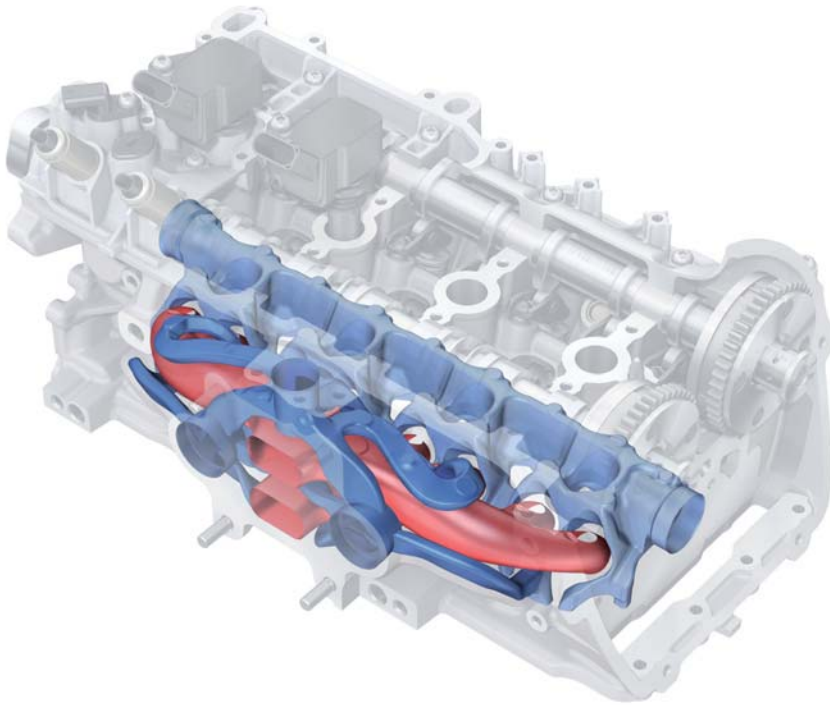

Optimised thermal management (rotary valve)

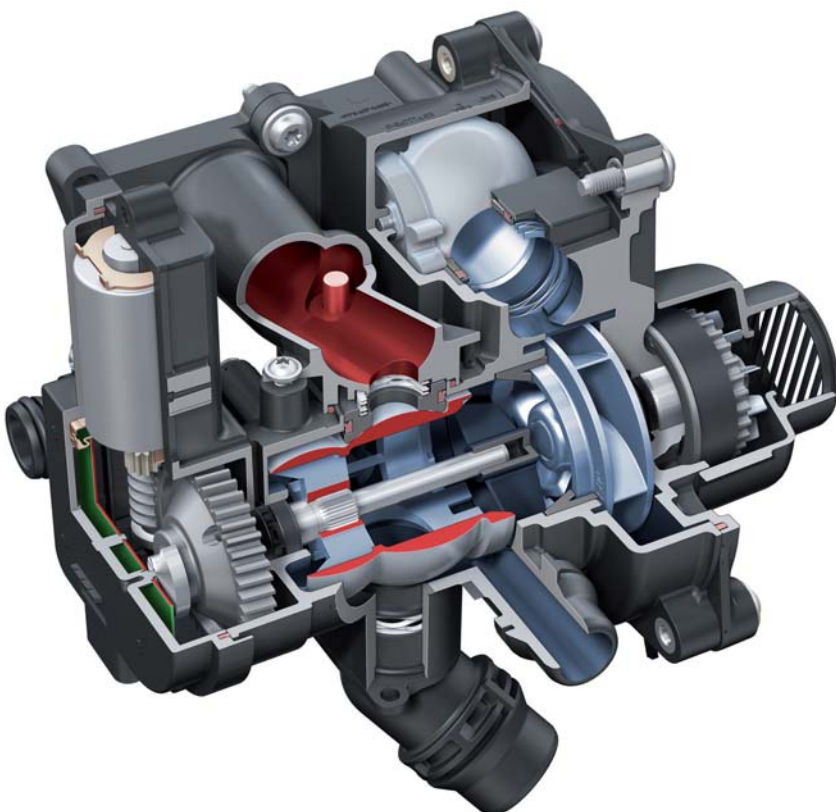

Combined FSI/MPI injection

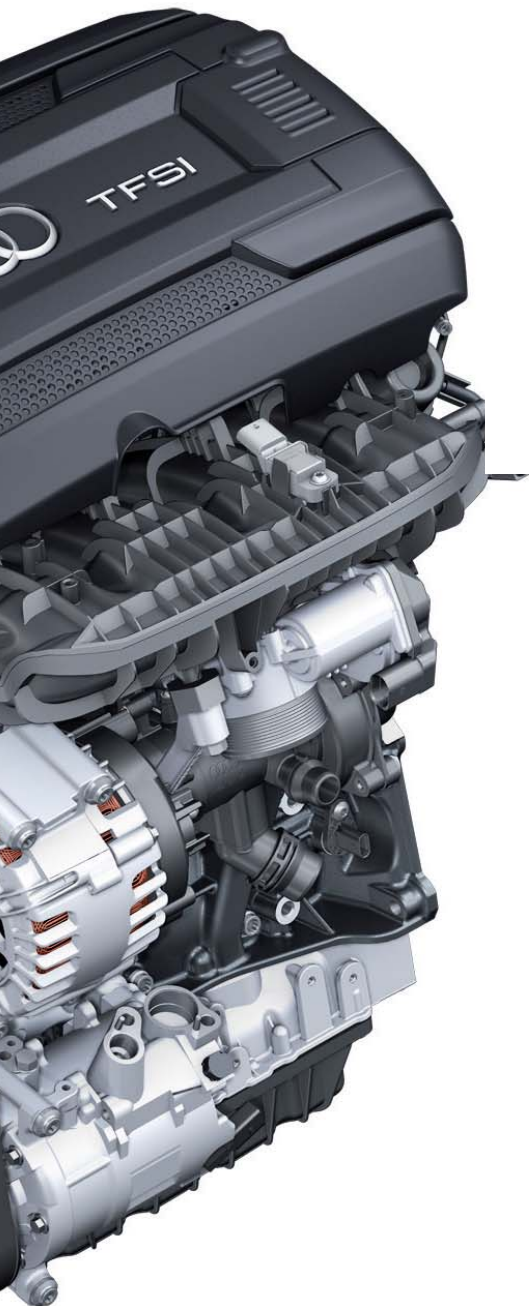
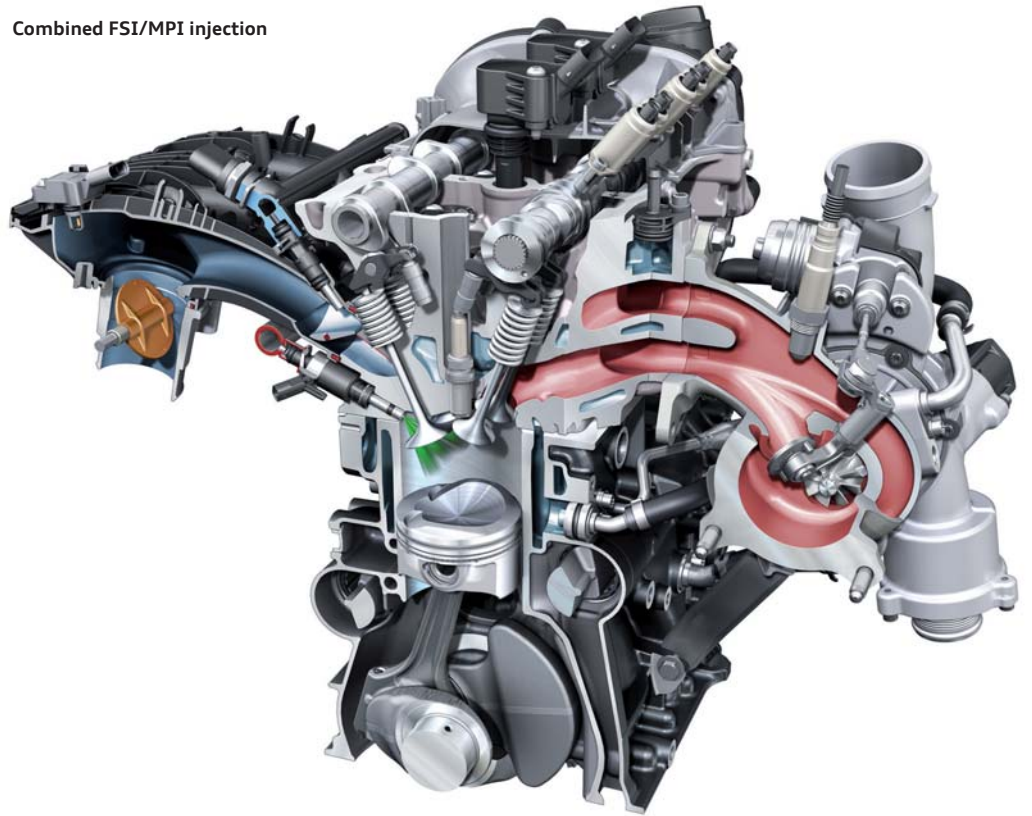

Friction optimisation and lightweight design

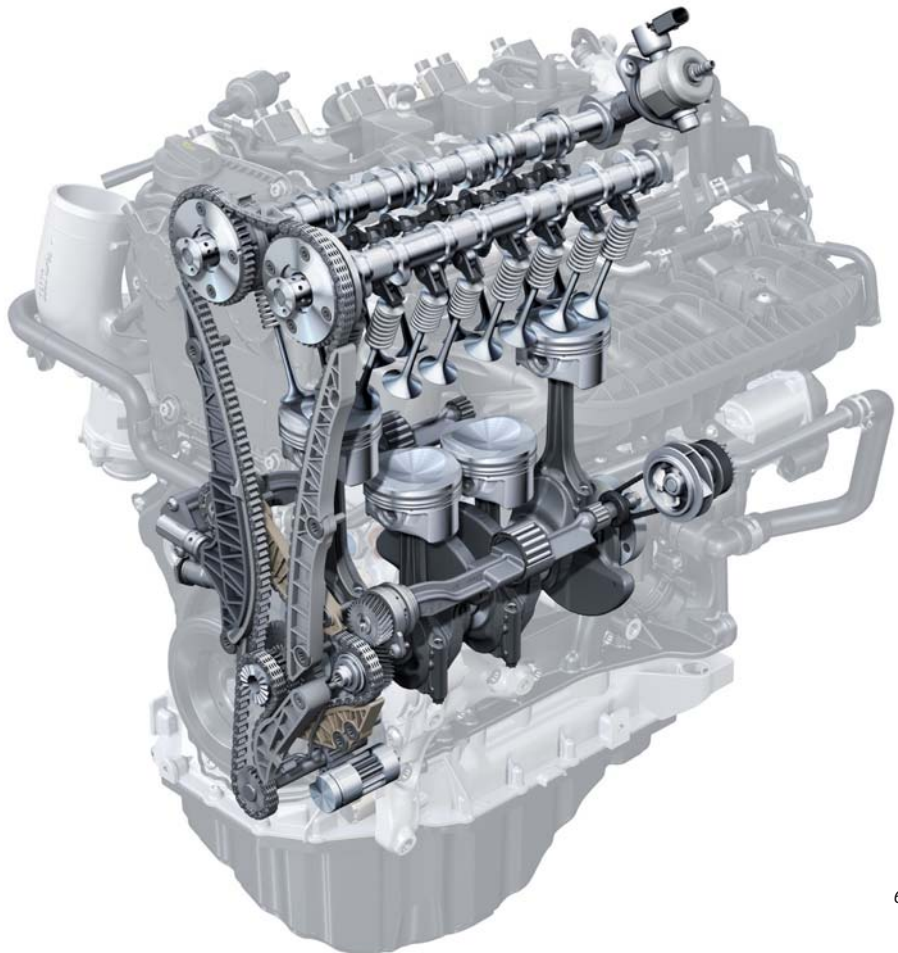

Specifications

Torque-power curve

1.4l TFSI engine with engine code CMBA

- Power in kW
- Torque in Nm



609_058

| | |
|--|-----------------------------|
| Engine code | CMBA |
| Type | Four-cylinder inline engine |
| Displacement in cm ³ | 1395 |
| Power output in kW (hp) at rpm | 90 (122) at 5000 – 6000 |
| Torque in Nm at rpm | 200 at 1400 – 4000 |
| Number of valves per cylinder | 4 |
| Bore in mm | 74.5 |
| Stroke in mm | 80 |
| Compression ratio | 10.5 : 1 |
| Engine management system | Bosch MED 17.05.21 |
| Fuel | Premium unleaded 95 RON |
| Emissions standard | EU 5 plus |
| CO₂ emission in g/km | 120 |

1.8l TFSI engine with engine code CJSА

- Power in kW
- Torque in Nm

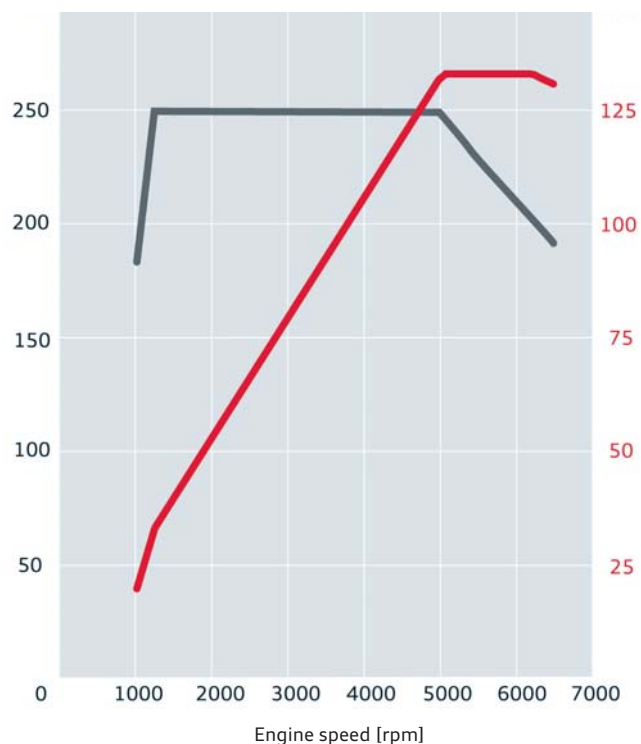

609_057

| | |
|--|-----------------------------|
| Engine code | CJSА |
| Type | Four-cylinder inline engine |
| Displacement in cm ³ | 1798 |
| Power output in kW (hp) at rpm | 132 (180) at 1250 – 6200 |
| Torque in Nm at rpm | 250 at 1250 – 5000 |
| Number of valves per cylinder | 4 |
| Bore in mm | 82.5 |
| Stroke in mm | 84.1 |
| Compression ratio | 9.6 : 1 |
| Engine management system | Simos 12 |
| Fuel | Premium unleaded 95 RON |
| Emissions standard | EU 5 |
| CO₂ emission in g/km | 130 |

Diesel engines

1.6l / 2.0l TDI engine

Technical features

Cylinder block with integrated balancer shafts (2.0l TDI engine only)

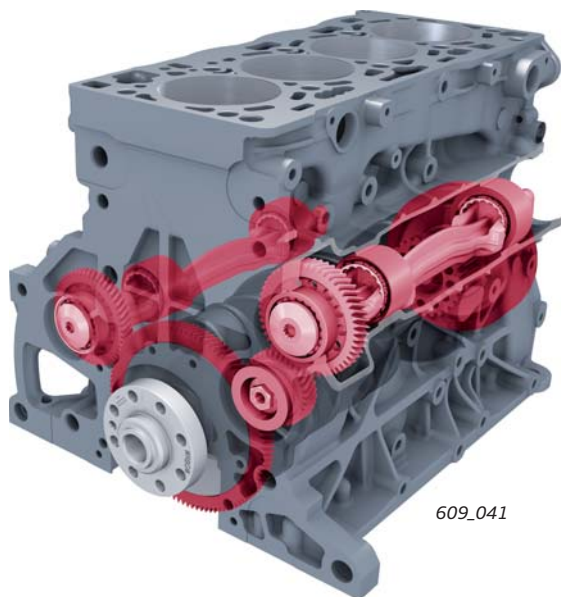

Oxidising catalytic converter and diesel particulate filter

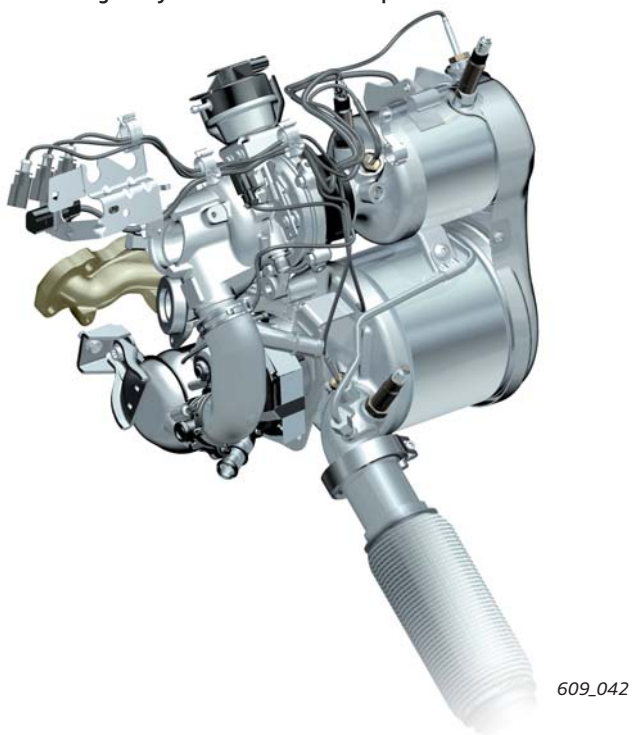

Cylinder head with variable valve timing
(engines conforming to EU6 emissions standard)

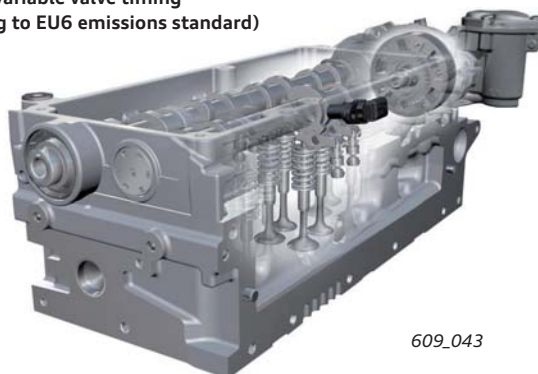

Oil pump with integral vacuum pump

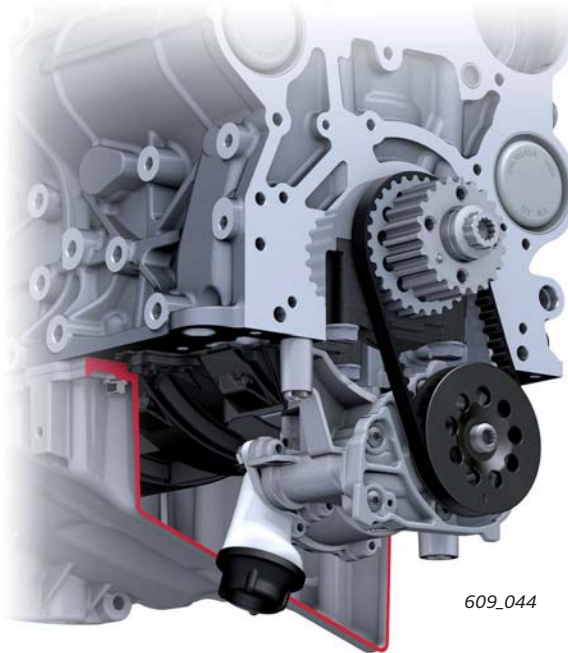

609_044

Active coolant pump

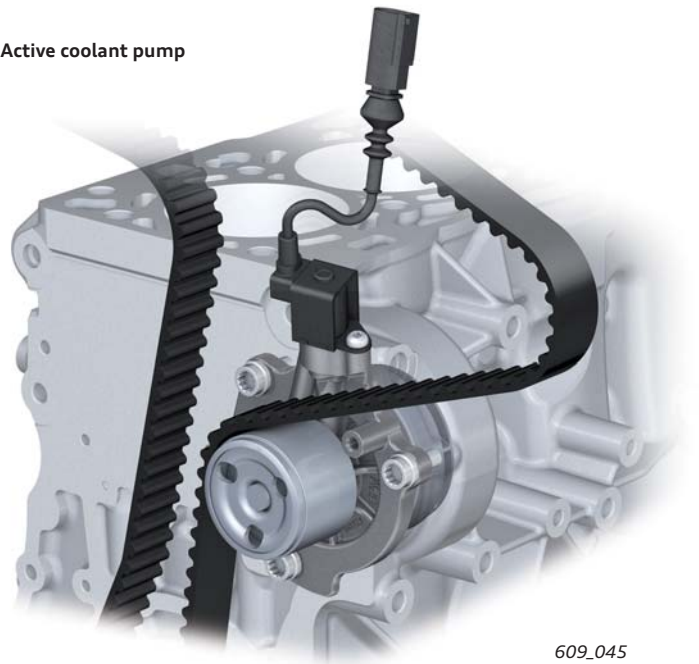

609_045

Intake manifold module with integrated charge air cooler

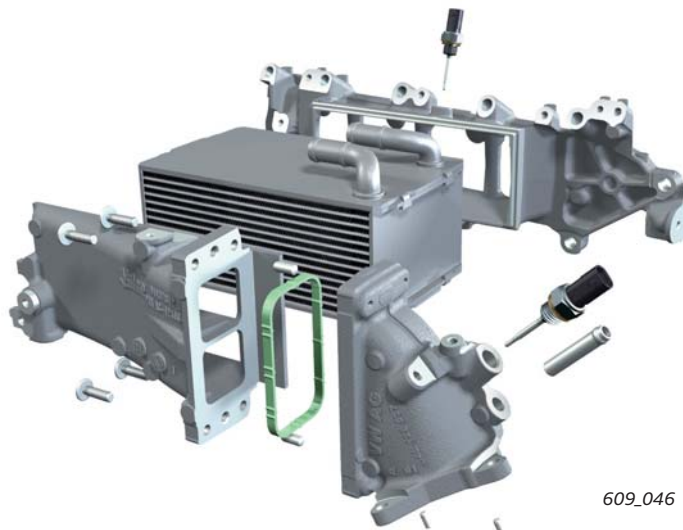

609_046



609_017

Specifications

Torque/power curve of 1.6l TDI engine

- Power output in kW
- Torque in Nm



609_048

| | |
|--|---|
| Engine code | CLHA |
| Type | Four-cylinder inline engine |
| Displacement in cm ³ | 1598 |
| Stroke in mm | 80.5 |
| Bore in mm | 79.5 |
| Cylinder spacing in mm | 88.0 |
| Number of valves per cylinder | 4 |
| Firing order | 1-3-4-2 |
| Compression ratio | 16.2 : 1 |
| Power output in kW at rpm | 77 at 3000 - 4000 |
| Torque in Nm at rpm | 250 at 1500 - 2750 |
| Fuel | Diesel to EN 590 |
| Engine management system | Bosch EDC 17 |
| Maximum injection pressure in bar | 1800 with solenoid valve injector CRI2-18 |
| Emissions standard | EU5 |
| CO₂ emission in g/km | 99 |



Reference

For further information about the design and operation of the 1.6l/2.0l TDI engine, refer to Self-Study Programme 608 "Audi 1.6l/2.0l TDI Engines".

Torque/power curve of 2.0l TDI engine

Engine with engine codes CRLB and CRBC

- Power output in kW
- Torque in Nm (CRLB)
- ⋯ Torque in Nm (deviation from CRBC)

Engine with engine code CUPA

- - - Power output in kW
- - - Torque in Nm

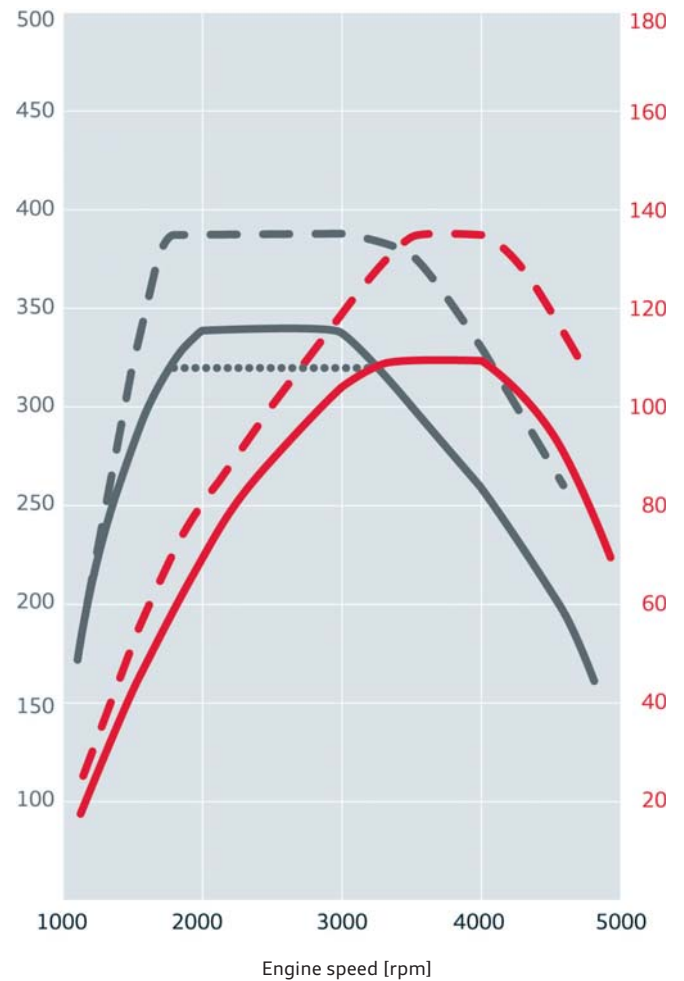

609_049

| Engine code | CRBC | CRLB | CUPA |
|-----------------------------------|---|---|---|
| Type | Four-cylinder inline engine | Four-cylinder inline engine | Four-cylinder inline engine |
| Displacement in cm ³ | 1968 | 1968 | 1968 |
| Stroke in mm | 95.5 | 95.5 | 95.5 |
| Bore in mm | 81.0 | 81.0 | 81.0 |
| Cylinder spacing in mm | 88.0 | 88.0 | 88.0 |
| Number of valves per cylinder | 4 | 4 | 4 |
| Firing order | 1-3-4-2 | 1-3-4-2 | 1-3-4-2 |
| Compression ratio | 16.2 : 1 | 16.2 : 1 | 15.8 : 1 |
| Power output in kW at rpm | 110 at 3500 – 4000 | 110 at 3500 – 4000 | 135 at 3500 – 4000 |
| Torque in Nm at rpm | 320 at 1750 – 3000 | 340 at 1750 – 3000 | 380 at 1750 – 3250 |
| Fuel | Diesel to EN 590 | Diesel to EN 590 | Diesel to EN 590 |
| Engine management system | Bosch EDC 17 | Bosch EDC 17 | Bosch EDC 17 |
| Maximum injection pressure in bar | 1800 with solenoid valve injector CRI2-18 | 2000 with solenoid valve injector CRI2-20 | 2000 with solenoid valve injector CRI2-20 |
| Emissions standard | EU5 | EU6 | EU5 |
| CO ₂ emission in g/km | 106 | - ¹⁾ | - ¹⁾ |

¹⁾ Data was unavailable at editorial deadline.

Fuel system

Various fuel systems are used in the Audi A3 '13. Various factors dictate which system is fitted in the vehicle:

- ▶ Engine type
- ▶ Auxiliary heater
- ▶ quattro or front wheel drive
- ▶ Climate zone of market

Front wheel drive models

1.4l TFSI engine

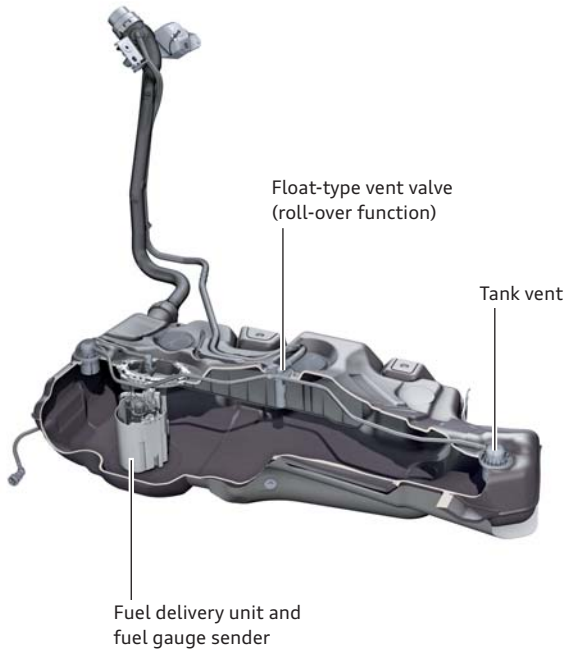

609_023

2.0l TDI engine

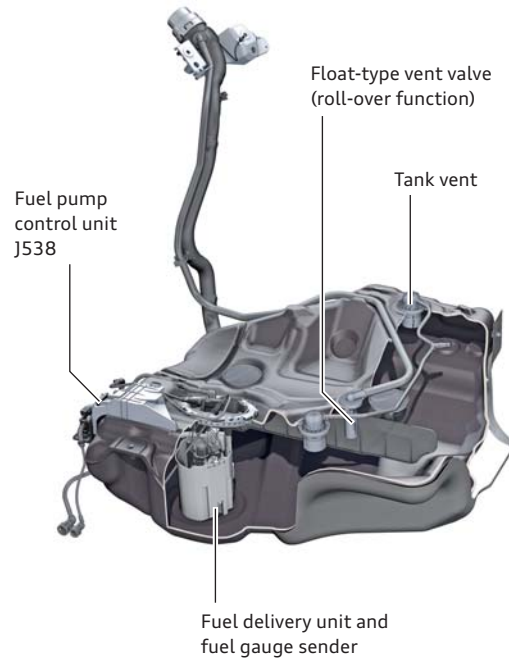

609_024

quattro models

Saddle-type fuel tanks are used in all-wheel-drive models.

1.8l TFSI engine

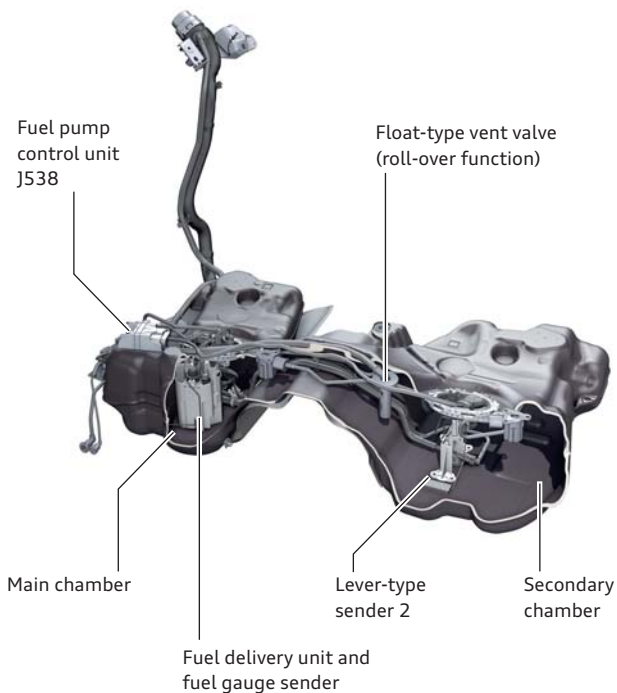

609_025

2.0l TDI engine

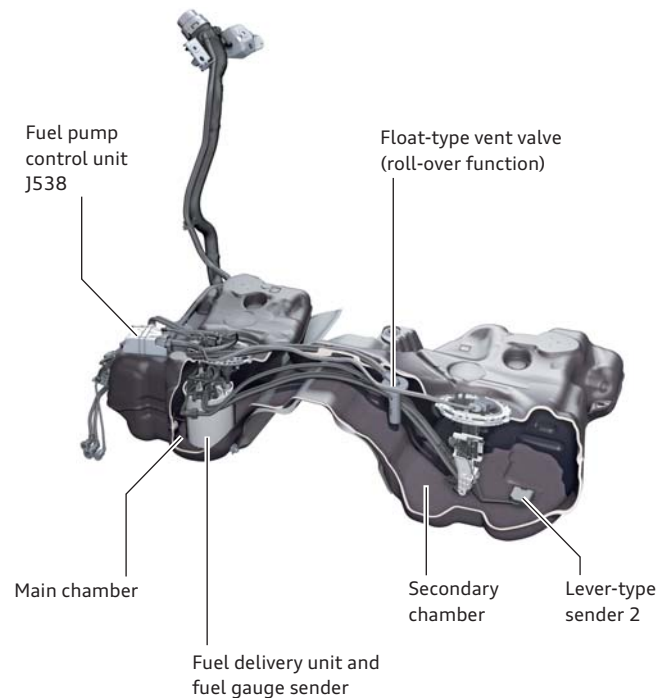

609_177

Exhaust system

1.4l TFSI engine

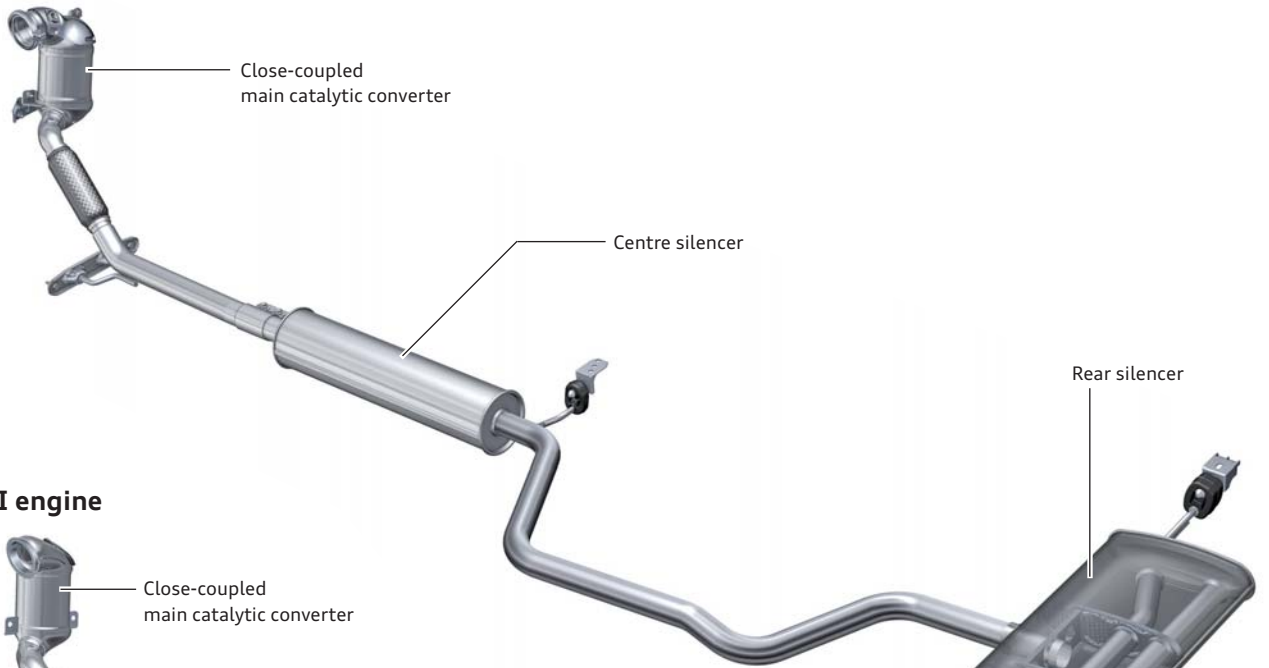

1.8l TFSI engine



2.0l TDI engine

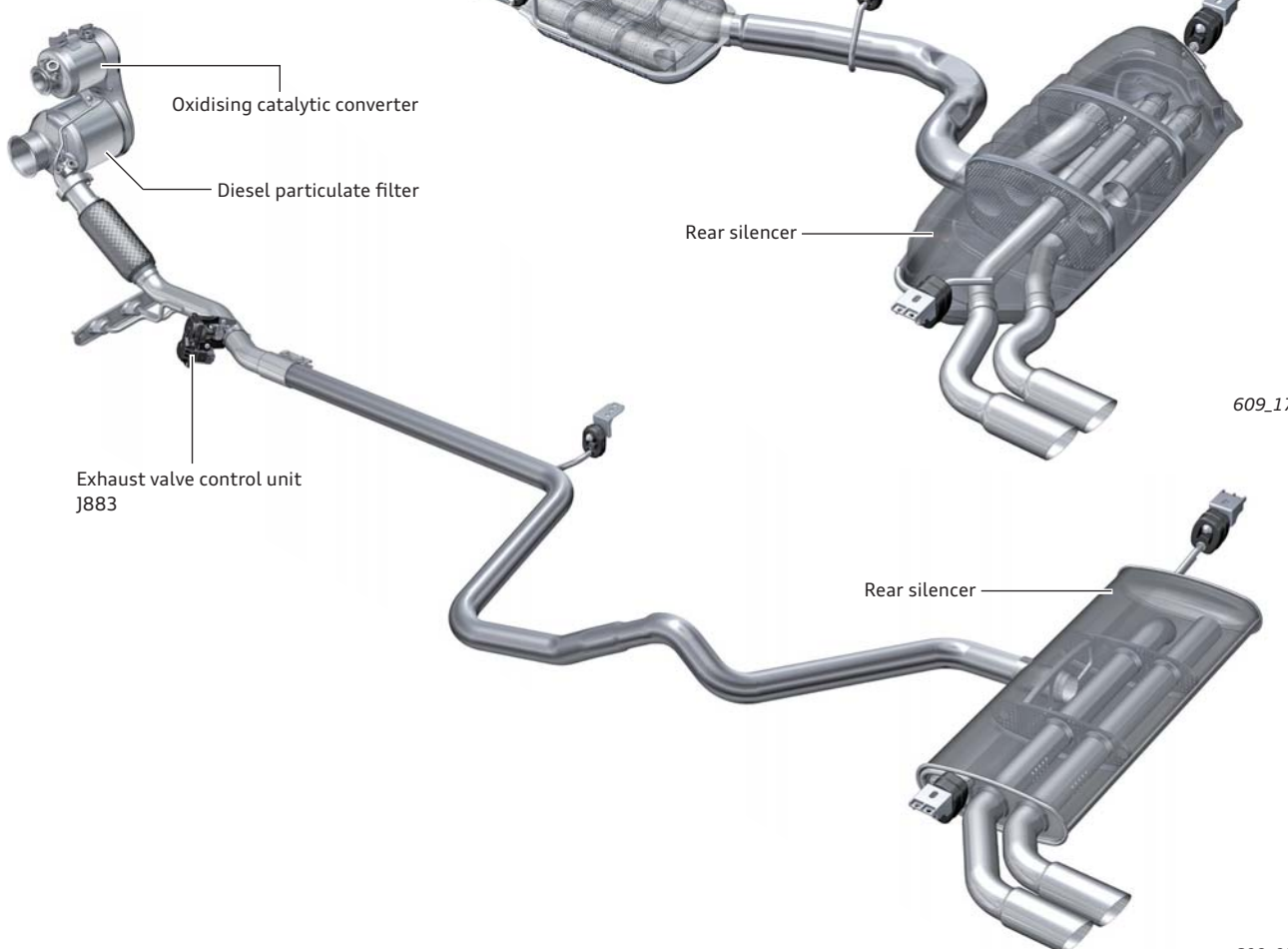

Engine/gearbox combinations

Petrol engines

1.2l TFSI engine¹⁾

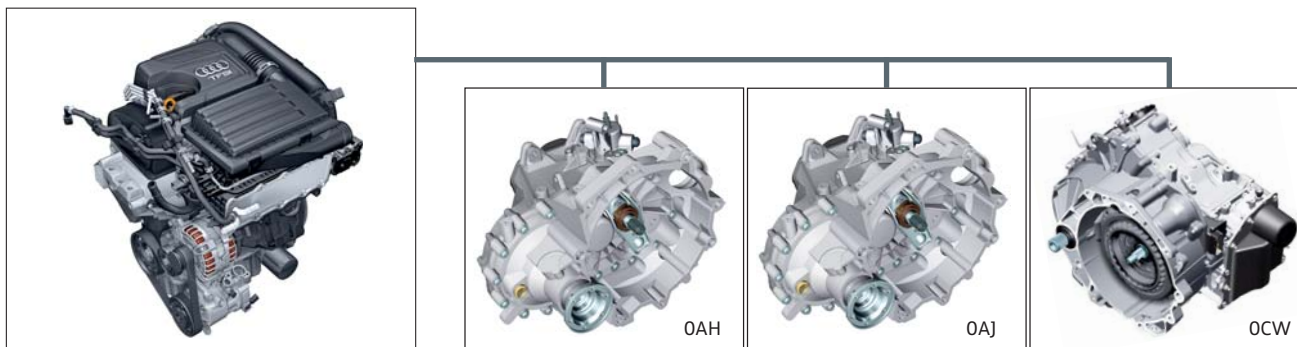

1.4l TFSI engine

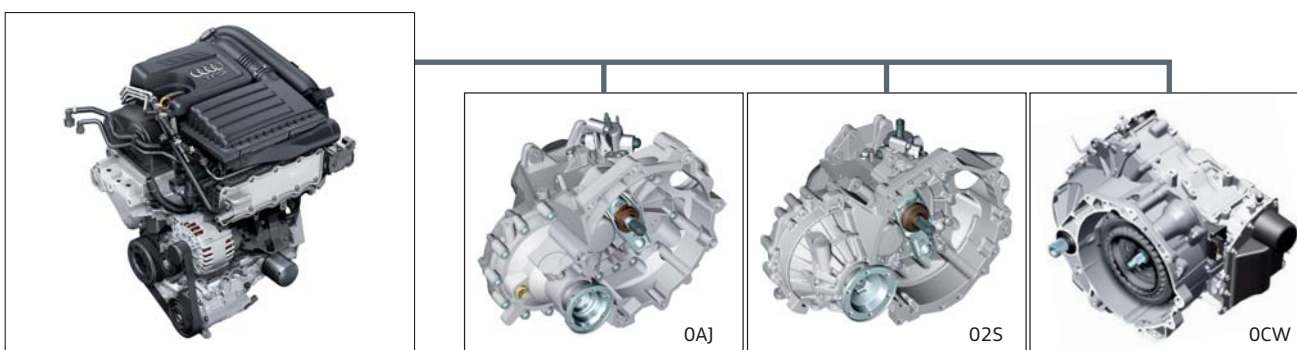

1.8l TFSI engine



2.0l TFSI engine¹⁾

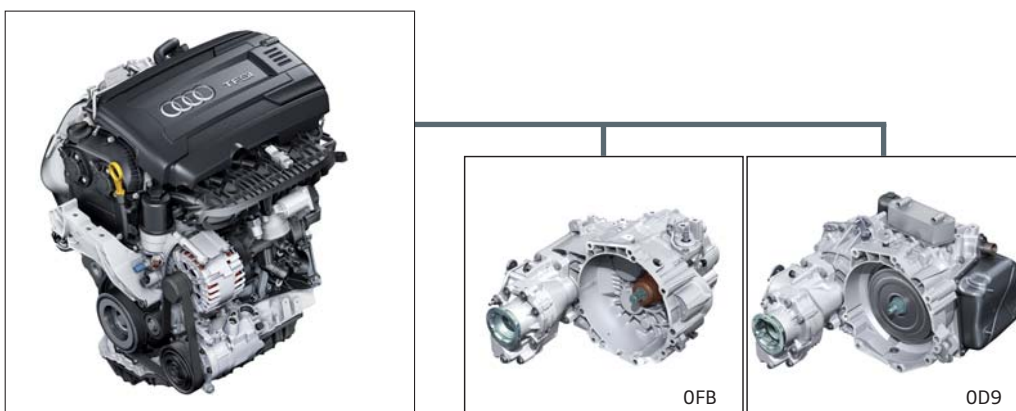

¹⁾ Engine will be introduced at a later date.

Diesel engines

1.6l TDI engine



2.0l TDI engine



Gearbox designations:

| | |
|-----|------------|
| 0AH | (MQ200_5F) |
| 0AJ | (MQ200_6F) |
| 02S | (MQ250_6F) |
| 02Q | (MQ350_6F) |
| 0FB | (MQ350_6A) |
| 0CW | (DQ200_7F) |
| 0D9 | (DQ250_6A) |

Breakdown of manufacturer designation:

e.g. MQ350-6F

| | |
|------------|---------------------------|
| M | Manual gearbox |
| D | Dual clutch gearbox |
| Q | Transverse installation |
| 350 | Nominal torque capacity |
| 6 | Number of gears |
| F | Front wheel drive |
| A | All-wheel drive (quattro) |

Power transmission

Overview

The power transmission system in the Audi A3 '13 is based on proven technology. The manual gearbox and the dual clutch gearbox are known from the predecessor model. The installation position was adapted in all gearboxes in the course of implementing the Modular Transverse Module, **MQB** for short. If the vehicle is equipped with Audi drive select and efficiency mode is selected, the dual clutch gearboxes assist this program in selector lever position D by activating the Freewheel mode. Refer to page 50 for more information. The dual clutch gearboxes also assist the start-stop system on a software basis and participate in the immobiliser system for the first time in this class of vehicle.

The 5th generation Haldex coupling and the selector mechanism are new Audi technology.

Installation location of gearbox

The installation position of the gearbox has been adopted to the modular transverse module by modifying the gearbox flanges and the gearbox mounting points. To differentiate the modified gearboxes from the previous gearboxes, the gearbox families have in some cases been renamed. Here is an example: The original 6-speed dual clutch gearbox 02E now has the designation 0D9. The 0D9 gearbox is inclined 12° further back than the 02E.

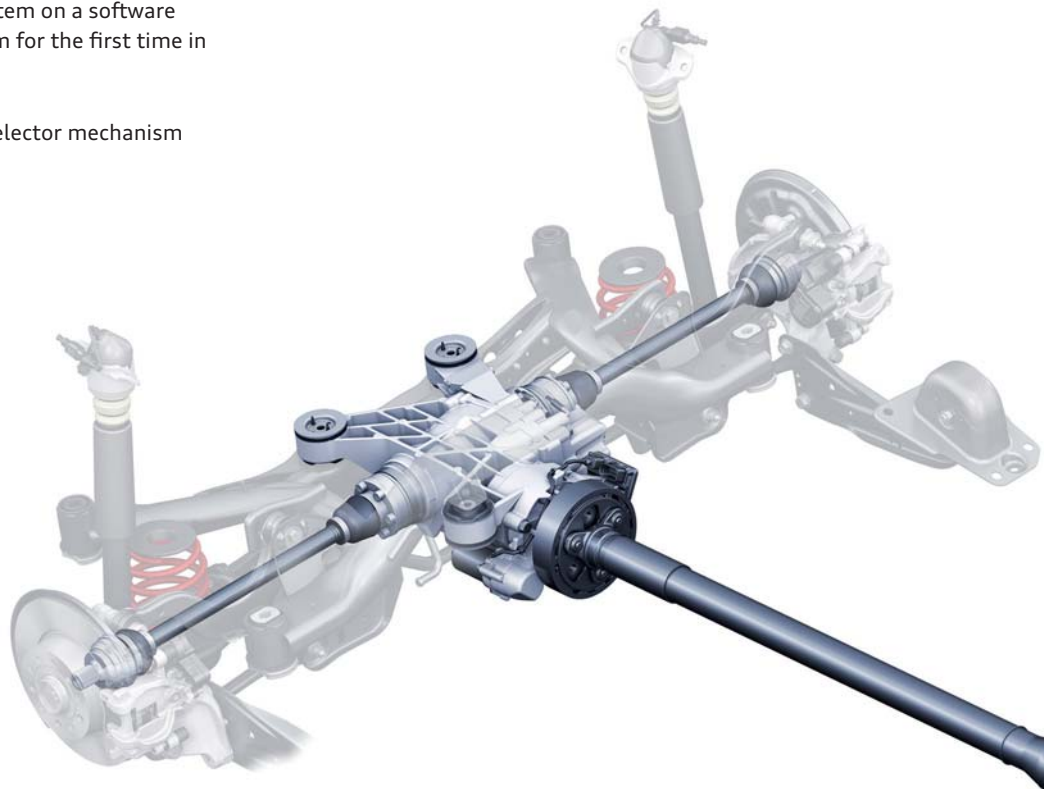

Rear axle drive 0CQ

Final drive

Rear axle drive vent

Haldex coupling vent

All-wheel drive control unit J492

Haldex coupling pump V181

Haldex coupling

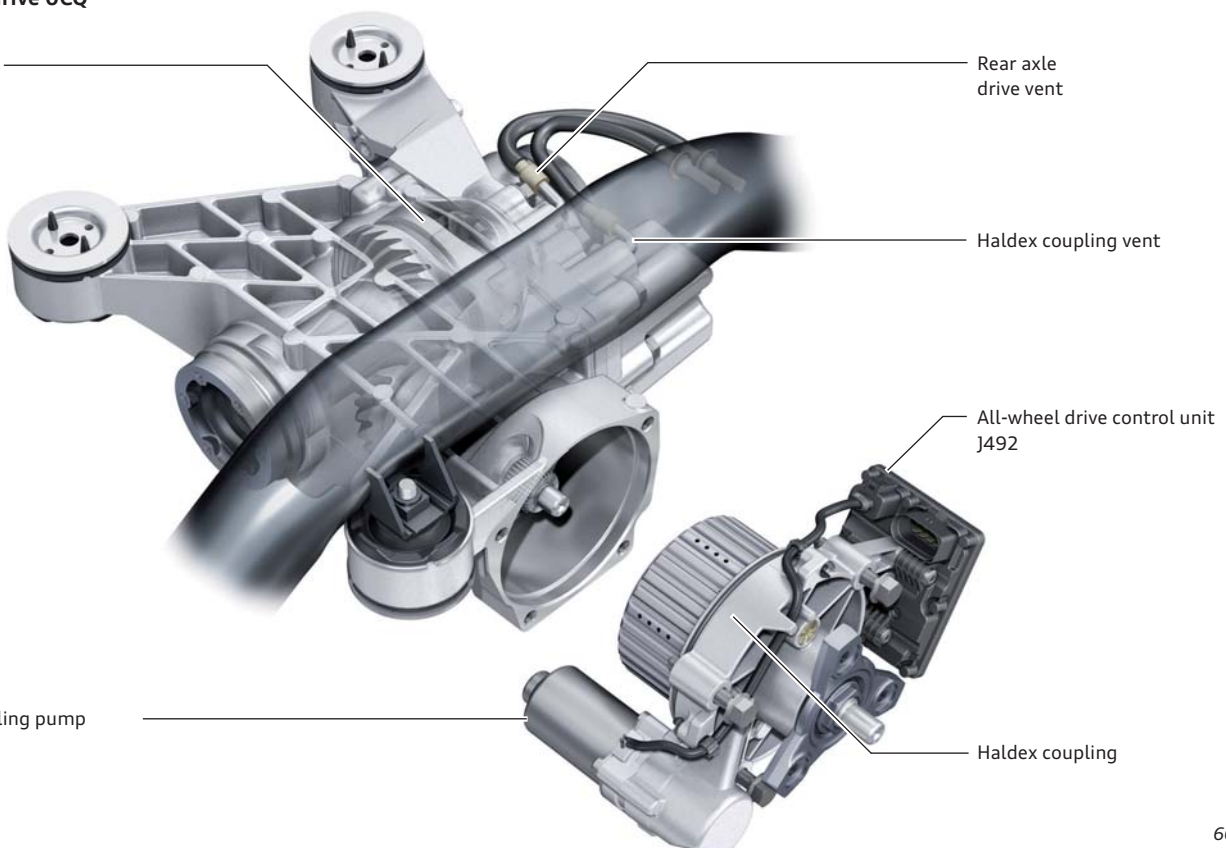

Innovative thermal management for OD9 gearbox

The OD9 dual clutch gearbox is at present the only gearbox of the Audi A3 '13 whose heat balance is integrated in the innovative thermal management system of the 1.8l TFSI engine. The gearbox cooling circuit is initially open during the starting phase of the cold engine. The gearbox coolant valve N488 is energised for this purpose. The engine control unit switches the valve to ground. If there is enough heat available for the engine and for heating the cabin to the temperature requested by the customer, valve N488 is deenergised. The cooling circuit is now closed and the ATF is heated to operating temperature by the heated engine coolant. The ATF temperature signal is transferred from the gearbox to the engine control unit by the powertrain CAN bus. If the ATF has reached operating temperature, valve N488 is re-energised and the cooling circuit is opened.

If the ATF temperature exceeds a permissible value, valve N488 is deenergised again. The cooling circuit is closed. Since the engine coolant temperature is kept below the maximum permissible ATF temperature in this case, the ATF is cooled by the engine coolant. For further information, refer to SSP 486, page 28 ff.

Gearbox coolant valve N488:

- Activated and diagnosed by the engine control unit J623.
- Energised: valve closed, open coolant circuit
- Deenergised: valve open, closed cooling circuit

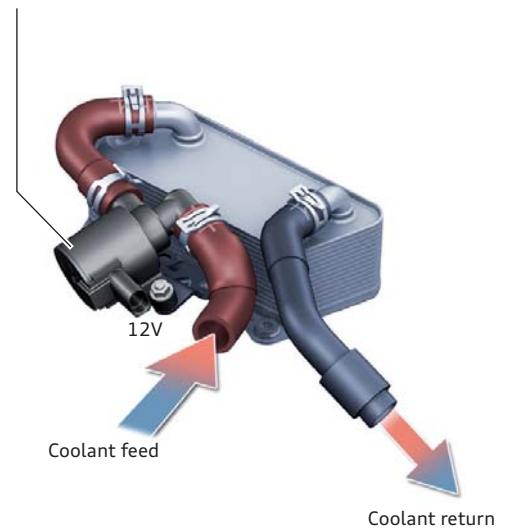

609_130

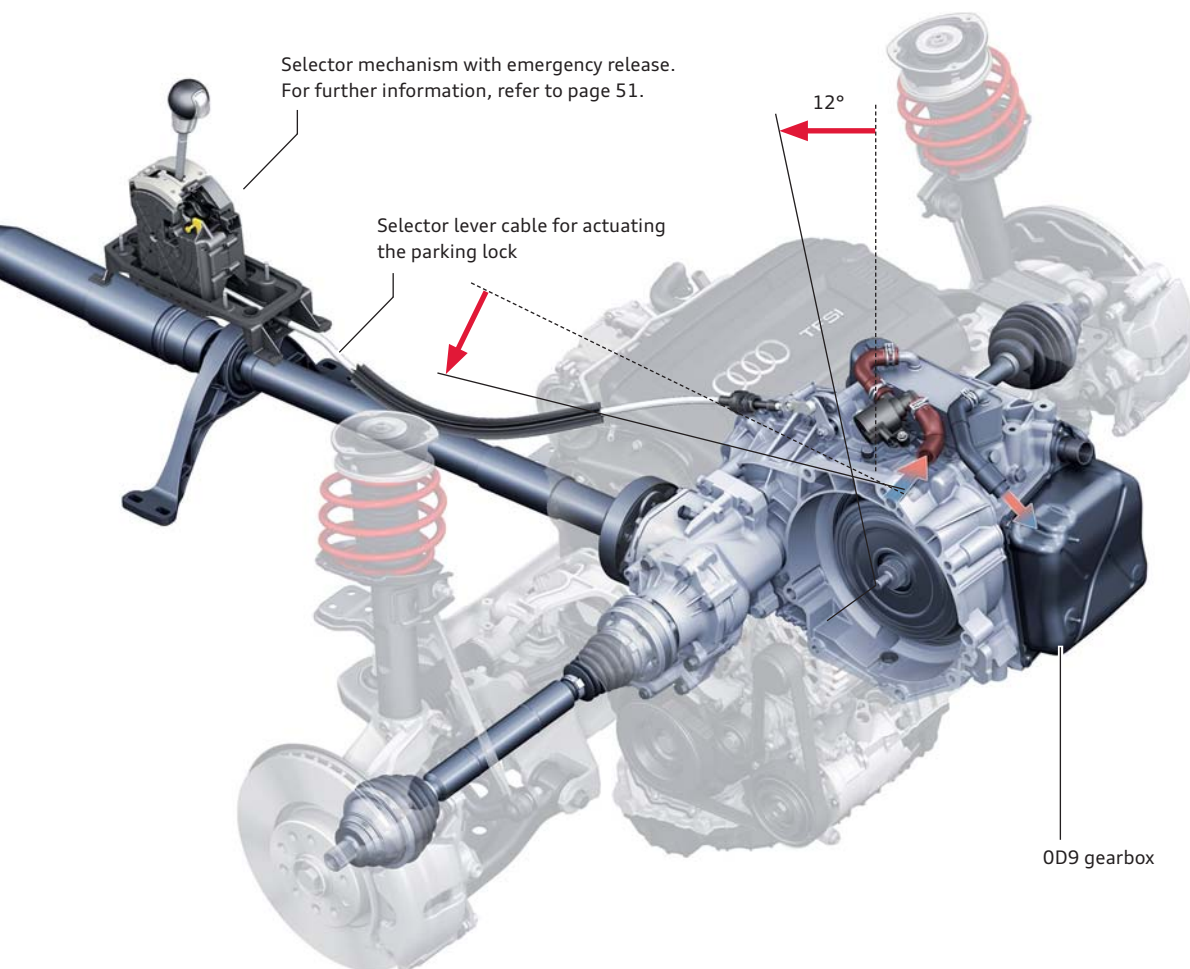

609_131



Note

The processes of the innovative thermal management system described on this page, refer to the 1.8l TFSI engine available at market launch. Engine types due out at a later date and deviating country-spec versions (hot climate/cold climate) are not considered.

5th generation Haldex coupling

Component overview

The control logic in the various driving situations was adopted from the 4th generation Haldex coupling (refer to Self Study Programme 414).

The most notable feature of the 5th generation Haldex coupling is a new pressure control system. The hydraulic pressure required for the Haldex coupling is produced by a pump with centrifugal governor.

Thanks to this technology, the new Haldex coupling is 1.7 kg lighter than the 4th generation Haldex coupling.

An electric motor drives the axial piston pump. The six axial pistons are pushed against an inclined thrust plate. When the pump cylinder rotates, the pistons execute an axial stroke and thus convey the Haldex oil to the pressure side of the pump.

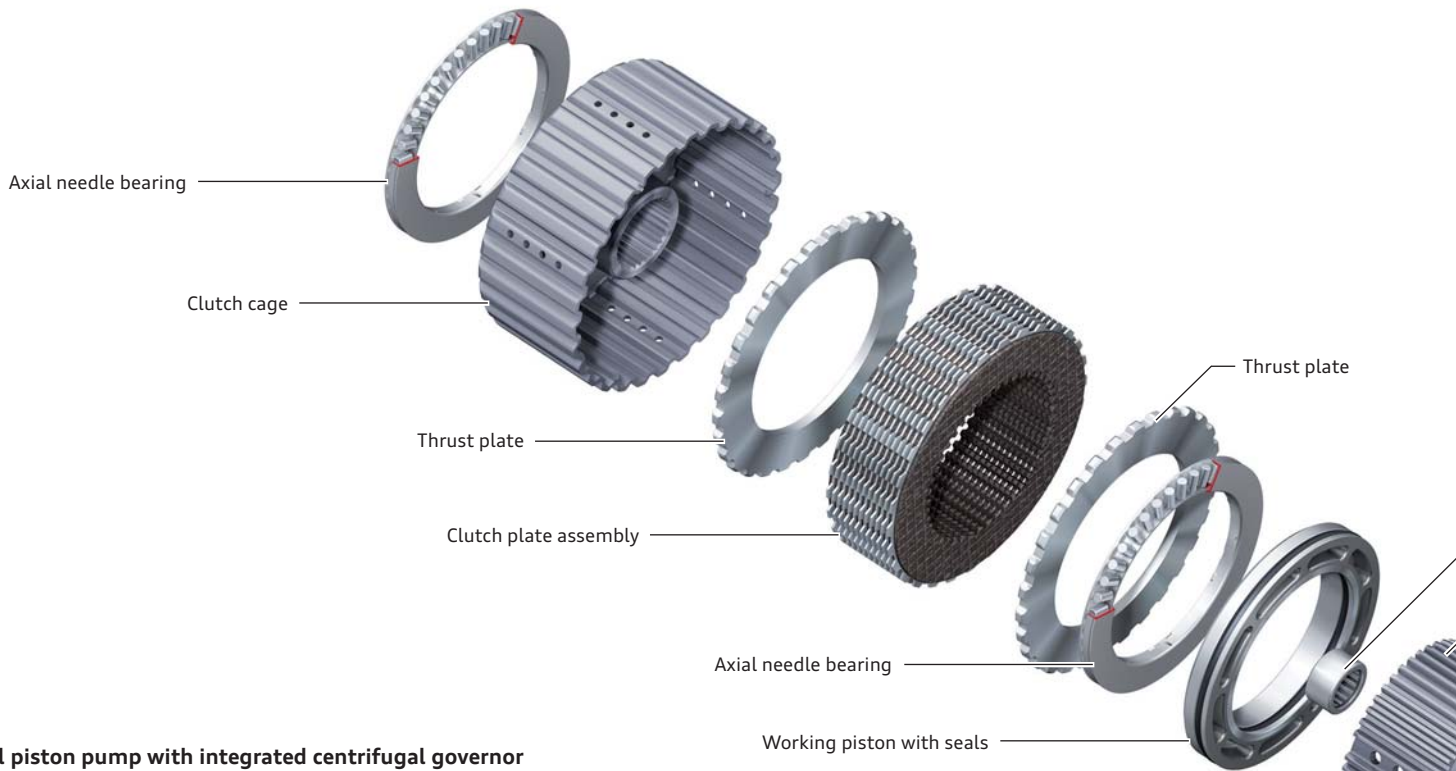

Axial piston pump with integrated centrifugal governor

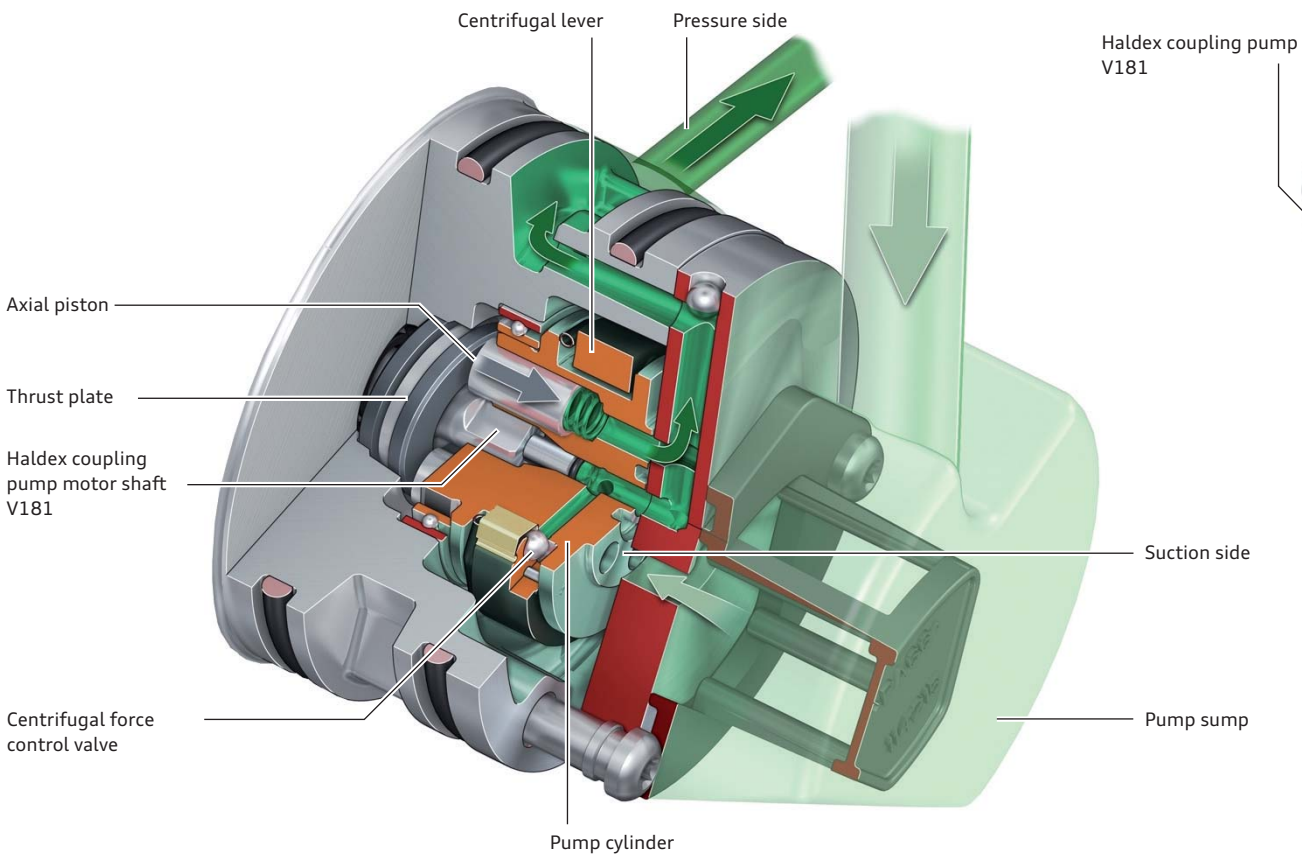

All-wheel drive control unit J492

The all-wheel drive control unit J492 exchanges information via the suspension CAN bus. The driving dynamics software computes the required clutch pressure according to the driving situation. The characteristic curves stored in the control unit are used to determine the pump output which generates the required hydraulic pressure in the working piston cylinder. To control pump output, the pump motor is supplied with a pulse width modulated voltage of 12V and the current input is measured.

The hydraulic pressure is determined as a function of current input based on the characteristic curves. If a higher pressure is required, pump output is increased by pulse width modulation of the voltage. Motor engine, pressure and current input increase. To reduce the pressure in the working piston cylinder, pump output is decreased. Motor engine, pressure and current input decrease. A sufficient supply of energy is ensured by the terminal 30 power supply, which is protected by a 15 A fuse.

Pressure relief valve

The valve ball is pushed down into the valve seat by a steel spring. At a hydraulic pressure of **44 bar**, the spring force is no longer sufficient and the valve ball unblocks the valve cross-section. The Haldex oil is displaced to the suction side of the axial piston pump.

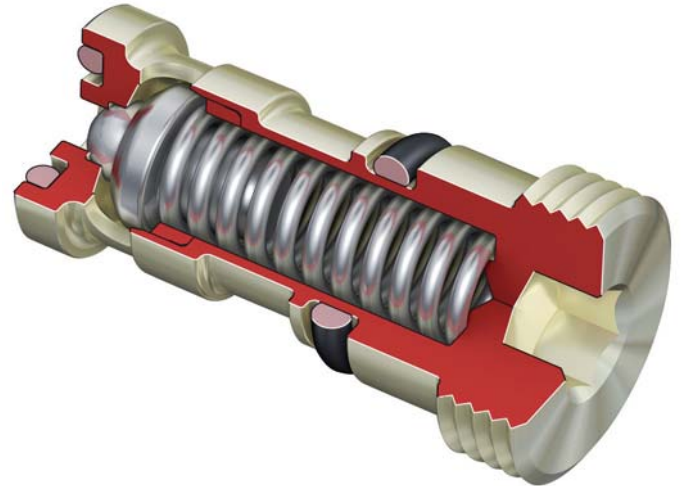

609_133

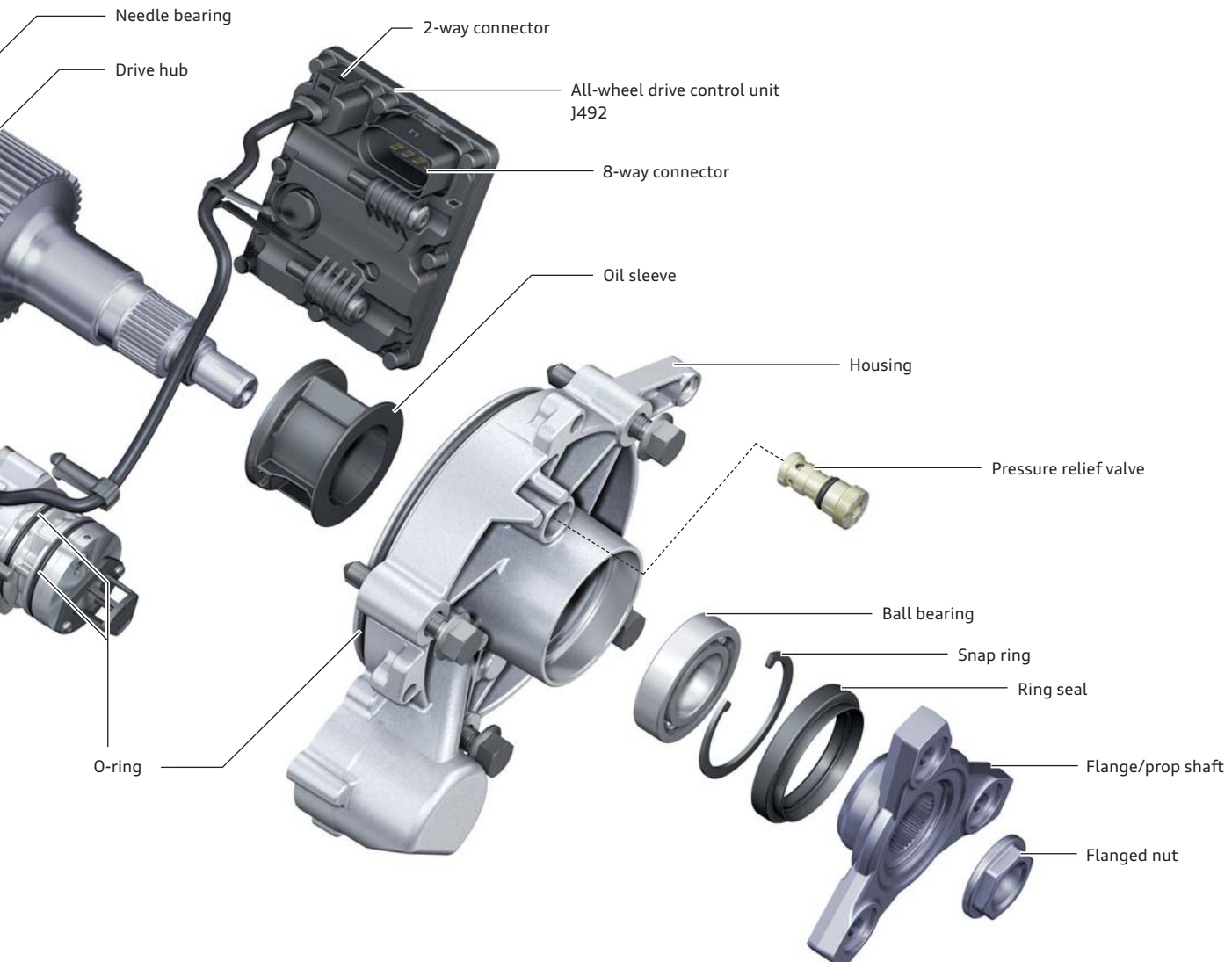

609_134

Oil supply / hydraulic diagram

The axial piston pump with integrated centrifugal governor is driven by the motor shaft of Haldex coupling pump V181. The centrifugal force acting on the centrifugal levers of the controller increases with axial piston pump speed. The valve balls of the centrifugal force control valves are thereby pushed down into the valve seat more firmly. This increases the pressure maintained by the valves.

With the aid of this technology, the system achieves outstanding pressure increase and reduction times.

The hydraulic pressure supply of the working piston is controlled by varying the speed of the motor of the Haldex coupling pump V181. If the speed of the motor increases, thereby increasing the pressure supplied to the working piston, the working piston applies more pressure to the clutch plate assembly allowing more torque to be transmitted. If the speed of the motor decreases, thereby reducing the pressure supplied to the working piston, less torque can be transmitted.

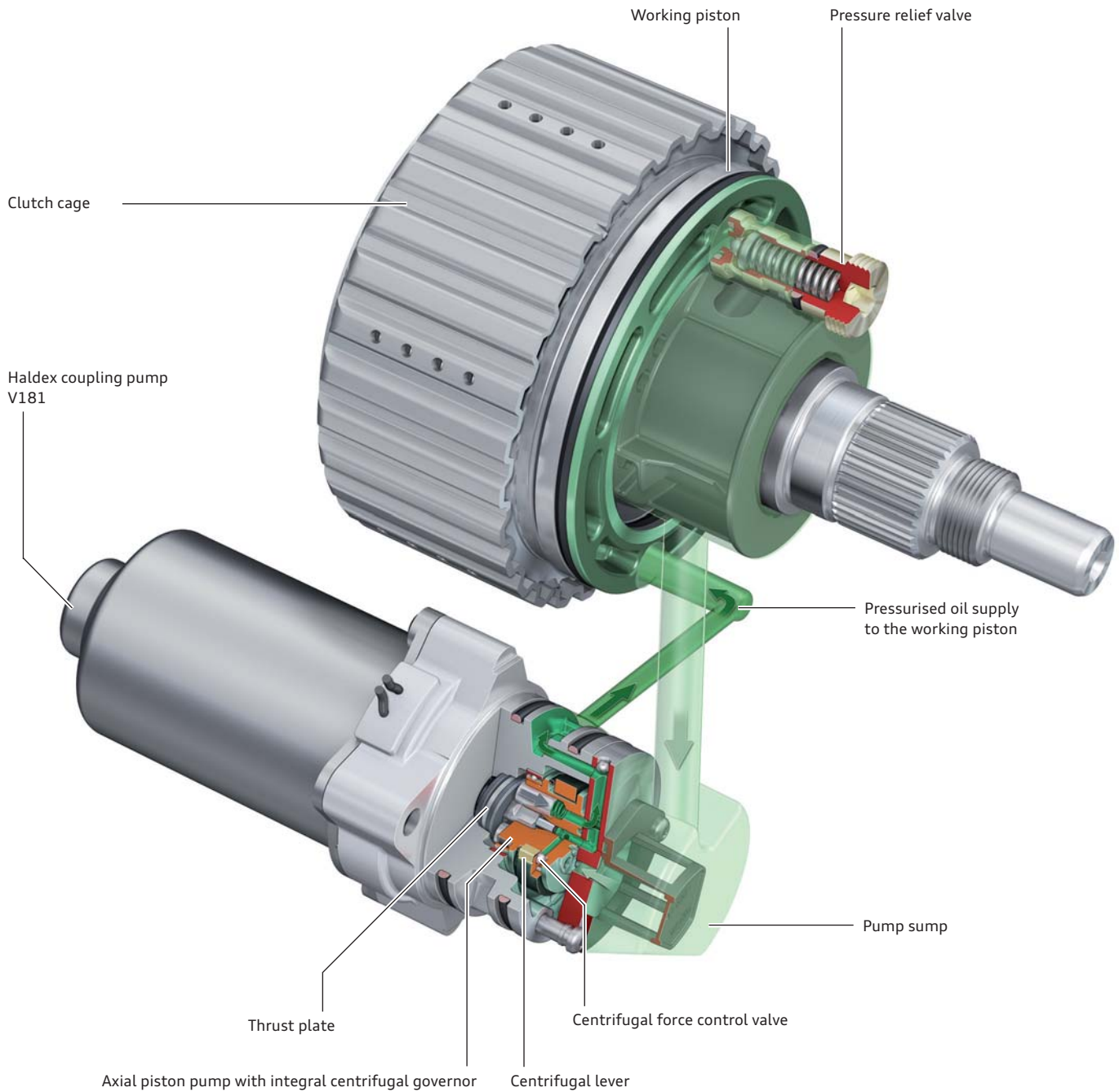

Low pump motor speed

There is still no pressure build-up inside the working piston's cylinder. Due to the low speed of the pump motor, the centrifugal levers do not apply pressure to the valve balls.

The pumped oil flows back into the pump sump through the centrifugal force control valves of the centrifugal governor.

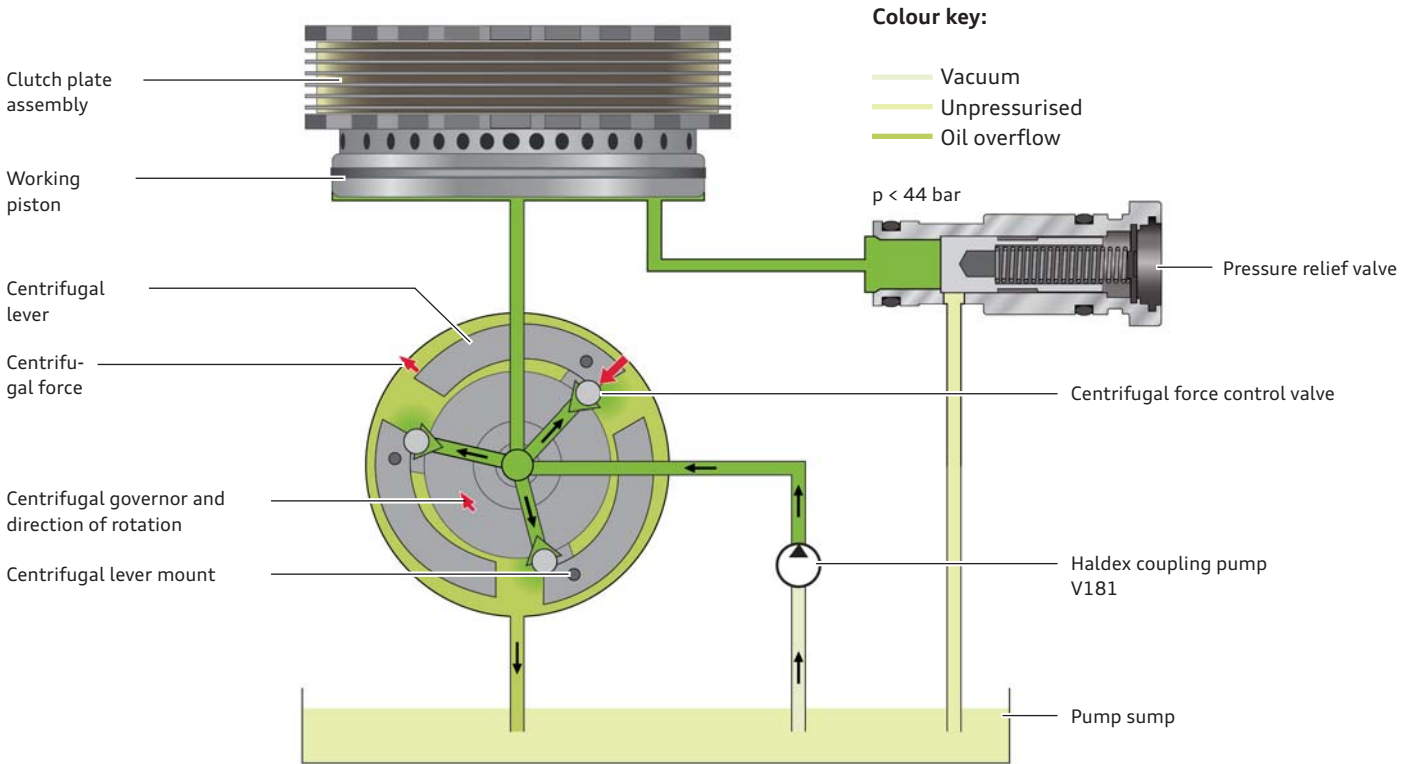

609_019

Pressure build-up due to increased pump motor speed

Pressure builds up inside the cylinder of the working piston. The centrifugal levers now apply pressure to the valve balls and close the gap. The rising pressure pushes the valve balls back slightly, bringing the centrifugal force and the hydraulic force into equilibrium.

The pressure inside the working piston, and hence the amount of torque which can be transmitted, rises with increasing motor speed.

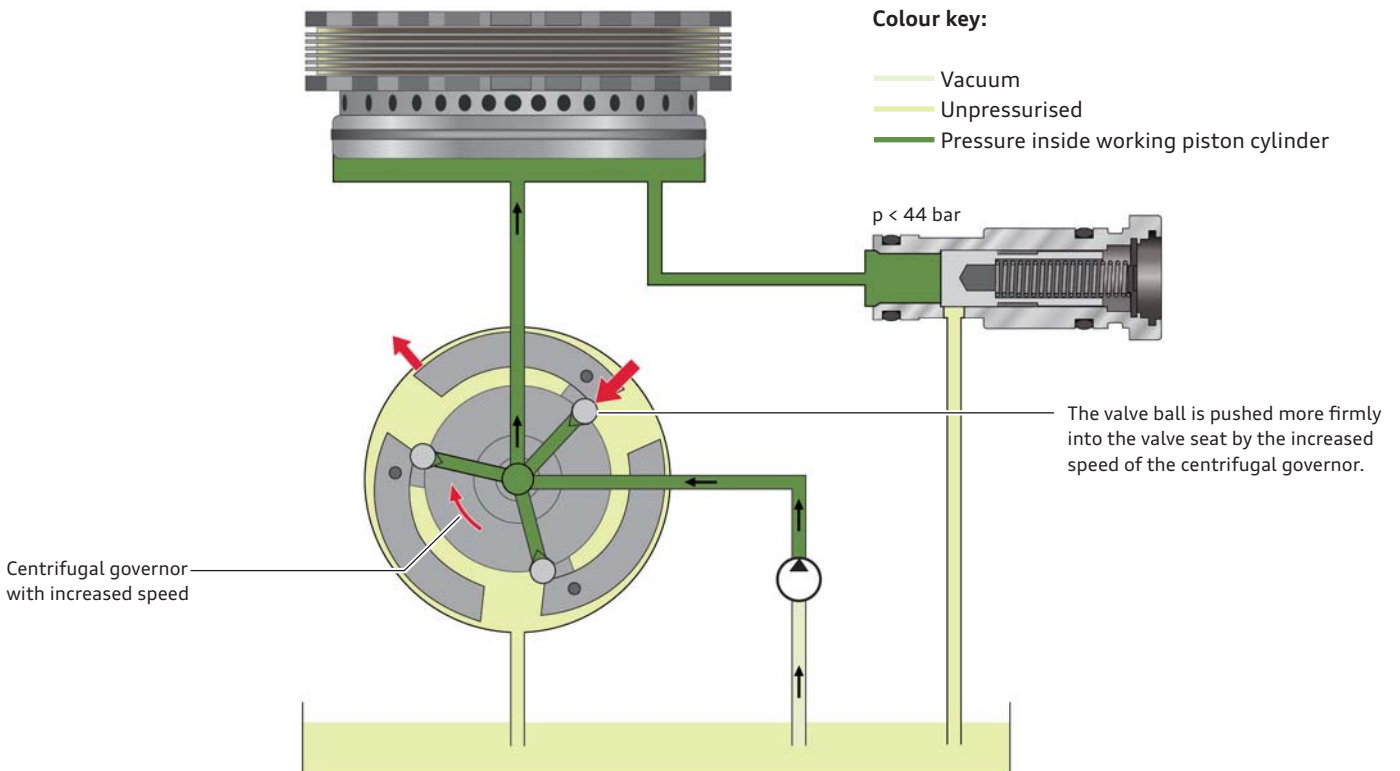

609_021

Overspeeding of pump motor

The centrifugal levers apply pressure to the valve balls to such an extent that the pressure inside the working piston cylinder rises to an unacceptable level.

When the pressure exceeds 44 bar, the pressure relief valve opens and limits the system pressure.

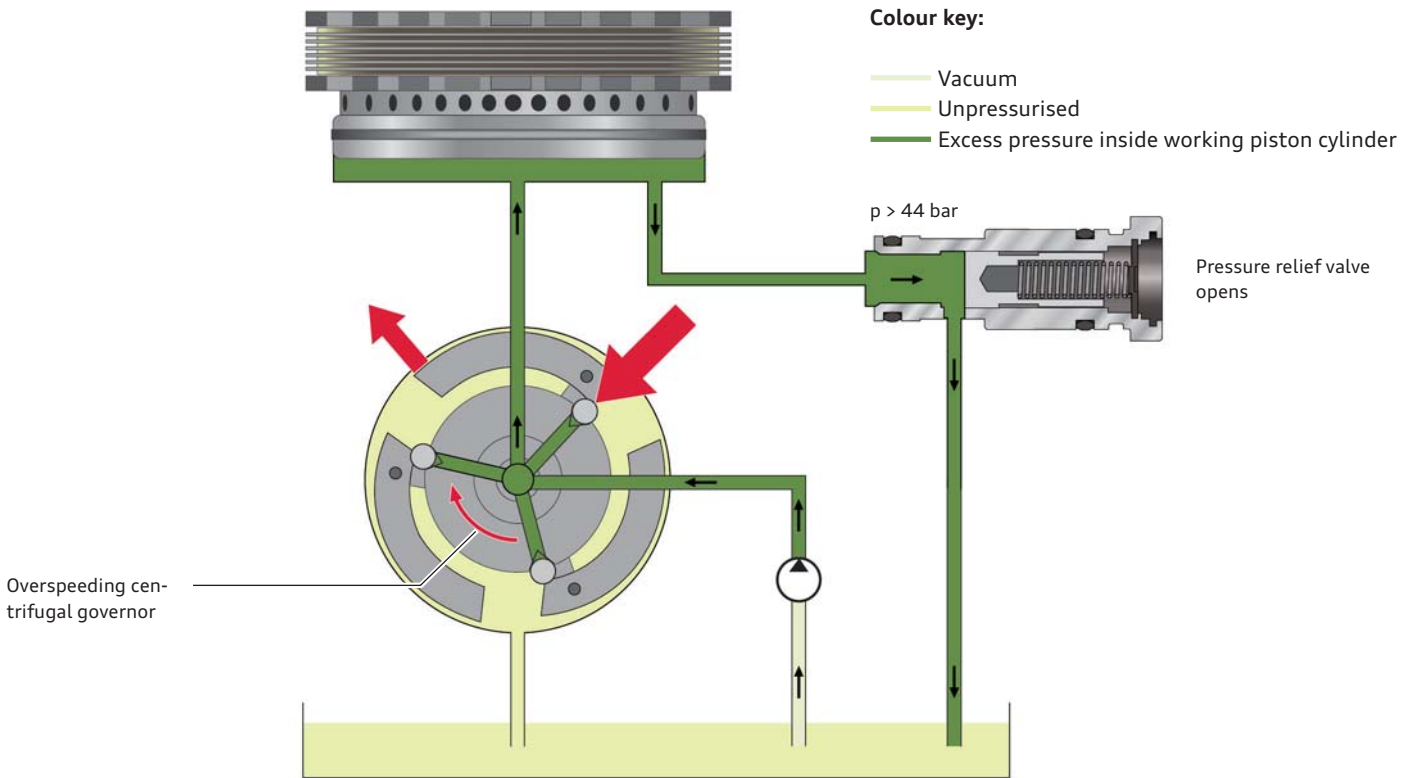

609_020

Pressure reduction due to decreased pump motor speed

The centrifugal levers exert less pressure on the valve balls. The pressure is relieved through the open valve gap until the centrifugal force and the hydraulic force are again in equilibrium.

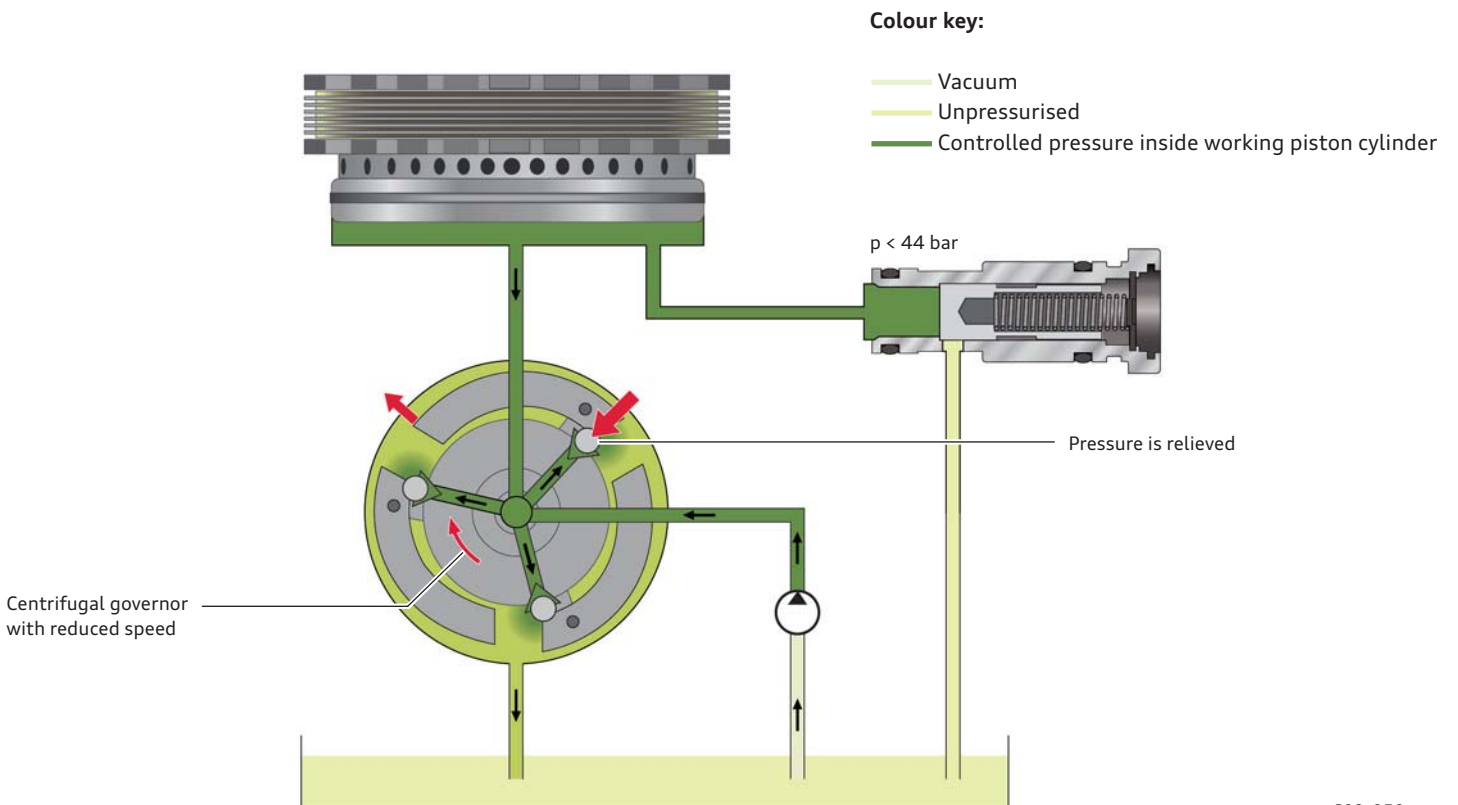

609_050

Function diagram

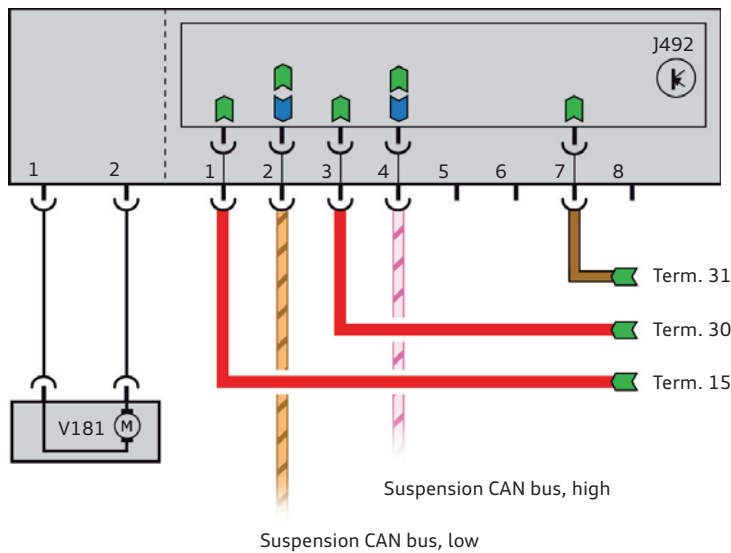

J492: All-wheel drive control unit
V181: Haldex coupling pump

609_136

The all-wheel drive control unit J492 communicates with the ABS control unit J104 and the power steering control unit via the suspension CAN bus.

It communicates with the dual clutch gearbox mechatronics J743, the engine control unit J623 and the control unit in dash panel insert J285 via the data bus diagnostic interface J533.

Service

The all-wheel drive control unit J492, the Haldex coupling pump and the flange/prop shaft are replaceable.

The seals for the housing, drive hub and pump are also replaceable.

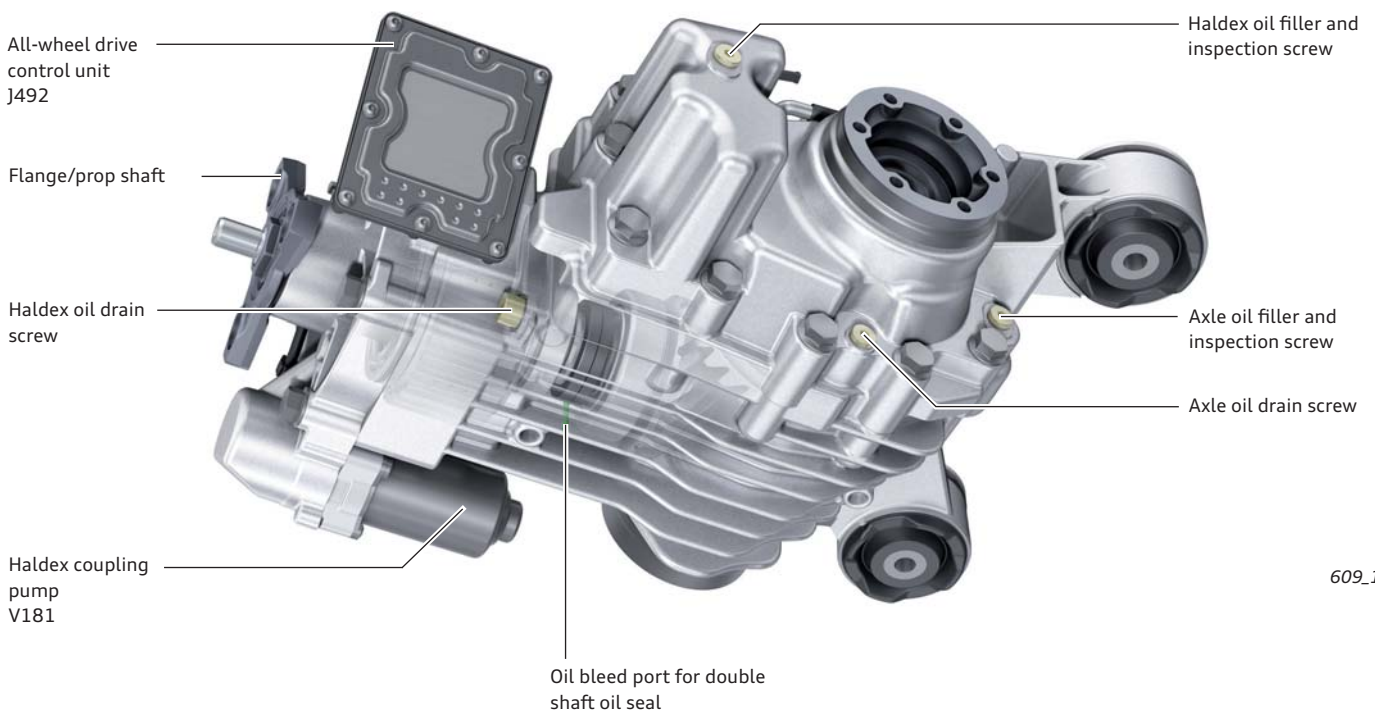

609_137

Change intervals

The Haldex oil must be changed every 3 years, regardless of mileage. The axle oil is not subject to a change interval.



Note

It is important not to mix up the Haldex oil and the axle oil when changing the Haldex oil. Use of the wrong oil can cause irreparable damage to components.

Diagnostics

The all-wheel drive control unit J492 can be selected with the vehicle diagnostic tester using address word 22.

The following functions can be activated:

- ▶ **Control unit identification**
- ▶ **Checking the SVM control unit configuration**
The validity of the software, the coding and the adaption channels for the vehicle is checked.
- ▶ **Event memory,**
Query and clear.
- ▶ **Actuator diagnostics**
To activate the actuator diagnostics, the internal combustion engine must be running, the temperature must be less than 60 °C and the vehicle must be at a standstill. If the actuator diagnostics are active, the multi-plate clutch is kept closed up to a speed of 6 kph. Driving the vehicle with the steering at full lock while the actuator diagnostics are active puts strain on the driveline, causing the rear axle to shudder.
The multiplate clutch opens when the vehicle reaches a speed of 6 kph, noticeably relieving the strain on the driveline - an indication that the Haldex coupling is working.

- ▶ **Basic setting**
The basic setting function can be used to assign the Haldex coupling pump V181 to a matching characteristic curve stored in the all-wheel drive control unit J492.
- ▶ **Read measured data**
- ▶ **Replace control unit**
Includes all the work operations necessary to replace the control unit.

Replacing the Haldex coupling pump V181

The first thing to do after replacing the Haldex coupling pump is to correct the Haldex oil level. An actuator test must then be performed on the stationary vehicle and the oil level checked again. Finally, a basic setting procedure must be performed.

Limp-home mode

On the printed circuit board of the all-wheel drive control unit J492 there are two temperature sensors which monitor the electronic components. The temperature of the multiplate clutches is calculated. Depending on the temperature threshold exceeded, the Haldex coupling is shut off. This is not indicated to the driver by a warning lamp.

Freewheel mode of dual clutch gearbox OD9 / OCW

In models equipped with Audi drive select, the driver can select efficiency mode using the drive select button in the centre console or via the Car menu in the MMI depending on which infotainment systems are fitted (refer to page 58 ff.).

In models with dual clutch transmission, an E is displayed in the instrument cluster for the selector lever position if efficiency mode has been activated and the selector lever is in D.

Under these conditions, the dual clutch gearboxes attempt to open the clutches and interrupt power flow to the engine while the vehicle is coasting (in overrun). This action is based entirely on software in the gearbox and helps to save fuel, thereby increasing vehicle efficiency.

If the clutches are open, the text "Freewheel" is displayed in the instrument cluster instead of the momentary fuel consumption.

In addition to the aforementioned conditions, the following criteria are relevant to clutch opening:

- ▶ Vehicle speed between 20 kph and maximum speed
- ▶ Accelerator position 0 % – power flow to the engine is interrupted directly after the 0 % accelerator position is detected and the last gearshift has been completed.
- ▶ Gradient < 8 % – the gradient is measured by the longitudinal acceleration sensor of the brake electronics.

Shut-off conditions:

- ▶ The brake is depressed.
- ▶ "tip minus" is selected on the steering wheel.
- ▶ The selector lever is moved out of D.
- ▶ The cruise control system is activated or is active. Activation or deactivation of the cruise control system does not constitute a shut-off condition.
- ▶ Gradient > 15 %
- ▶ When the vehicle is travelling downhill, it accelerates to faster than the cruise control system's set speed.

While the vehicle is freewheeling, the gearbox control unit preselects a gear suited to the speed at which the vehicle is travelling, thereby allowing the clutch to close comfortably at any time.

The engine speed drops to idle speed during the freewheeling phase. If the freewheeling phase occurs at a high vehicle speed, e.g. 180 kph, the engine takes between one and two seconds to achieve the required synchronisation speed.



609_172



609_174

Selector mechanism



609_138

Selector lever position display unit Y26

Selector lever position

If the selector lever is in P, switch F319 is open. It is closed in all other positions. The information "selector lever in P", "switch F319 open" cancels the ignition key removal lock and is required to enable engine starting. If there is a short circuit to ground in the line, the engine cannot be started and the ignition key cannot be removed in models without an advanced key.

Selector lever positions P, R, N and D/S and the tiptronic signals "tiptronic gate recognition", "tip plus" and "tip minus" are registered by the selector lever sensors control unit J587 and indicated to the dual clutch gearbox mechatronics J743 via the powertrain CAN bus. To shift from D to S (or from S to D), the selector lever need only be flicked backwards out of D/S once only. The selector lever always springs back to the D/S position.

Parking lock emergency release mechanism

The parking lock emergency release mechanism can be accessed by unclipping the selector lever gaiter from the centre console and pushing the insulating foam to the side.

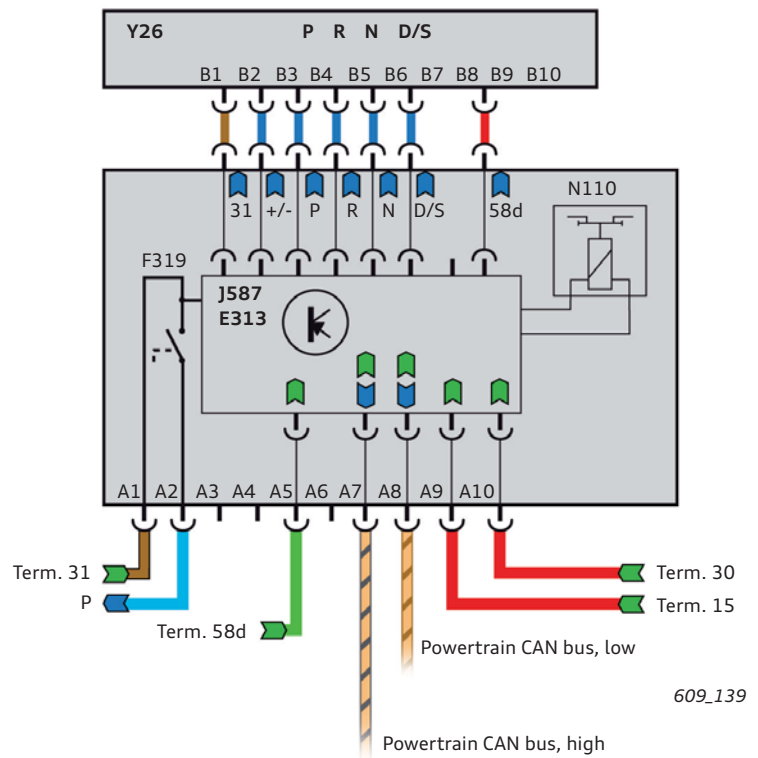

609_139

- E313** Selector lever
- F319** Selector lever locked in P switch
- J587** Selector lever sensors control unit
- N110** Selector lever solenoid
- Y26** Selector lever position display unit
- P** Discrete line, to the steering column electronics control unit J527 in vehicles without advanced key, and to electronic steering column lock control unit J764 in vehicles with advanced key.



Emergency release mechanism

609_140

Suspension system

Overall concept

A major development goal for the suspension system of the Audi A3 '13 was to achieve a high level of agility, sporty handling and a high standard of driving comfort without making any compromises on driving dynamics.

The interplay of all specially co-ordinated suspension components contributes to active safety. Even in its basic configuration, the Audi A3 '13 offers brand-typical driving and vibration comfort with a strong emphasis on sporty attributes. Thus, it provides a high level of driving enjoyment.



609_141

The following suspension system versions will be offered for the Audi A3 '13:

Dynamic suspension

The dynamic suspension system is standard in the Audi A3 '13.

Sports suspension

The sports suspension is optional. In models with sports suspension, ride height is 15 mm lower than in models with the standard suspension. The sports suspension will be available at launch of the Audi A3 '13.

Heavy-duty suspension

The heavy-duty suspension is optionally available for specific markets with bad roads. The ride height is 15 mm higher than that of the standard suspension system. The heavy-duty suspension system will become available after the launch of the Audi A3 '13.

Suspension system with electronic damping control

This suspension system is also available as an option for models with engine outputs of 103 kW and higher. It is based on the Audi Magnetic Ride system currently featured in other Audi models. This suspension system will become available after the launch of the Audi A3 '13.



Reference

For further information about the suspension system in the Audi A3 '13, refer to Self Study Programme 612 "Audi A3 '13 Suspension System".

Front suspension

A newly developed McPherson front suspension with wishbones and independent struts is used. The front suspension kinematics give the vehicle sporty and dynamic qualities (agile handling, excellent vibration and roll comfort, low roll angle and good dynamic stability).

Steering forces are transmitted directly to the swivel bearings so as to provide immediate steering response.

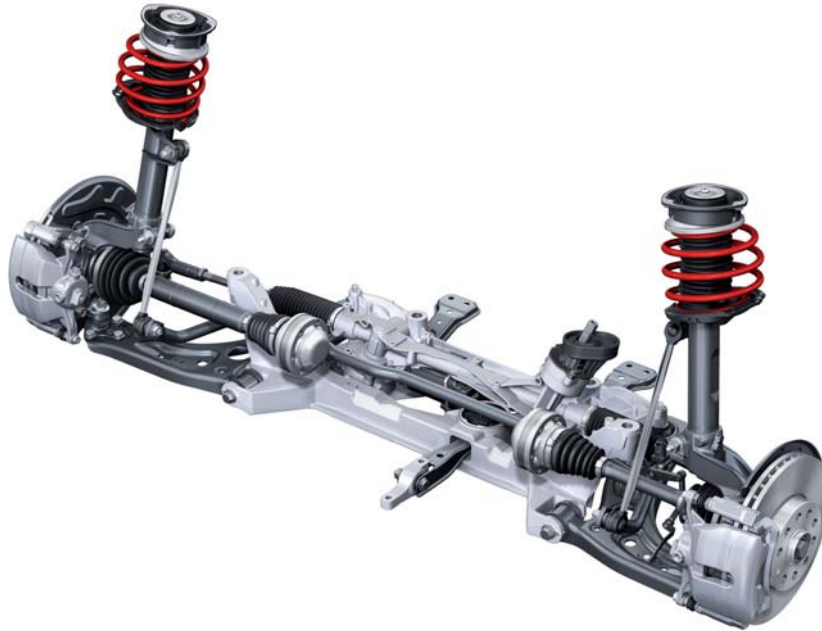

609_142

Rear suspension

Torsion beam suspension

A newly developed torsion beam suspension system is used for front wheel drive models with engine outputs of less than 85 kW. Two versions of the suspension system will be used for models with dynamic suspension and sports suspension. Torsion is produced by a downward-facing U profile. The new axle design eliminates the need for an anti-roll bar.

The axle location bearings have high transverse rigidity in order to ensure the rapid build-up of lateral traction. Since the shock absorbers are in approximately the same positions as in the multi-link suspension, only minor bodyshell modifications are needed in order to accommodate vehicles with torsion beam suspension and multi-link suspension.

Multi-link suspension

A four-link suspension for quattro and front wheel drive is used for vehicles with engine outputs of 85 kW and upwards. The basis for the new development is the proven rear suspension from the predecessor model. The shock absorbers are now coupled to the spring link instead of to the wheel carrier like in the predecessor model. The anti-roll bars are also connected to the spring link.

Spring travel has been increased in order to enhance comfort. Fuel tank filling has been optimised by repositioning the upper damper bearings. The weight of the axle has been significantly reduced by approx. 4.5 kg by paying close attention to lightweight design.



609_143



609_144

Steering system

Overview

The steering system concept has been adopted from the predecessor model for the Audi A3 '13.

This includes the electro-mechanical steering system, a mechanically adjustable steering column and an extensive range of steering wheel options.

A four-spoke steering wheel is standard equipment

Four-spoke steering wheels and a three-spoke sports wheel in various versions are optional.

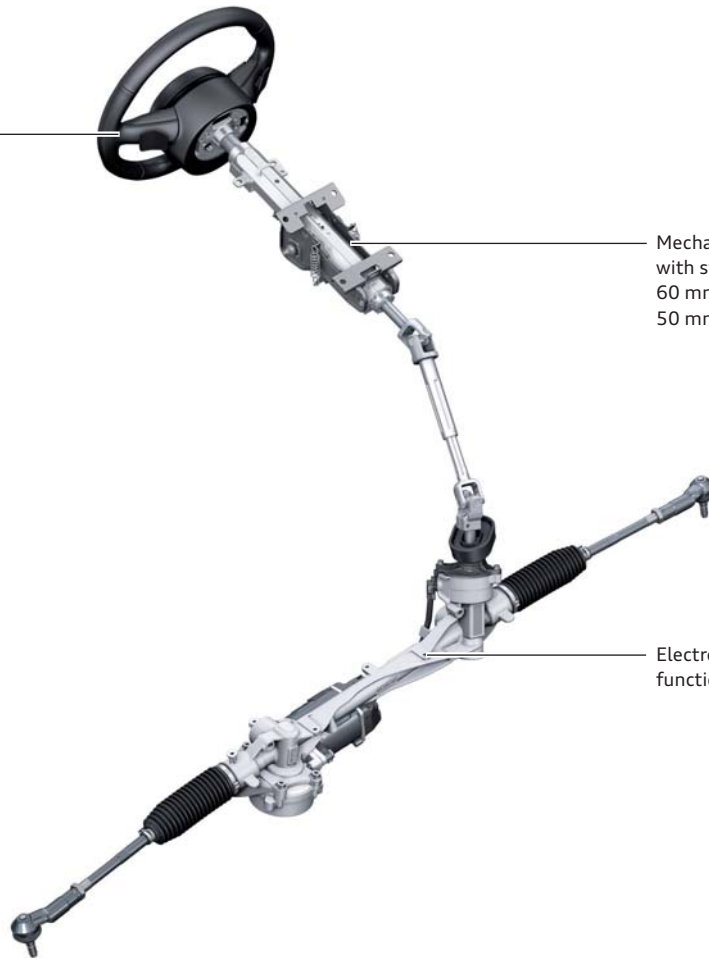

Mechanically adjustable safety steering column with stepless adjustment
60 mm longitudinally
50 mm vertically

Electro-mechanical steering with Servotronic function as standard equipment

609_145

Electro-mechanical steering

Design and function

The functional principle of the steering system has been adopted unchanged from the predecessor model. Torque assistance is provided by a second steering pinion driven by an electric motor. A torque sensor determines the steering torque applied by the driver. The electronic control unit determines the required torque assistance in dependence on steering torque, vehicle speed, steering angle, steering speed and other input variables. A significant modification compared to the predecessor model is the use of a synchronous pinion drive motor in place of an asynchronous motor. By making this modification and by redesigning the geometry of the steering housing, the overall weight of the steering unit has been reduced by approximately 2.5 kg.

The position of the electric motor's rotor is registered by a rotor speed sender built into the motor. This sender has the same functional principle as that used in the predecessor model. A temperature sensor integrated in the control unit measures the output stage temperature. If a predetermined limit is exceeded, power steering assistance is incrementally reduced. If a system fault is detected, power steering assistance is deactivated. System faults are indicated to the driver visually by a yellow or red indicator lamp and audibly by gong signals.



Reference

For detailed information about the design and function of the electro-mechanical steering system, refer to Self Study Programme 313 "Audi A3 '04 Suspension".

Brake system

Overview

The brake system of the Audi A3 '13 is a logical progression from the brake system of its predecessor. At the start of production, 15 and 16 inch systems will be used on the front axle and a 15 inch system on the rear axle. The brake systems outperform those of the predecessor model at comparable engine power output.

Pistons with larger diameters are used on all models, resulting in sportier pedal feel. The electro-mechanical parking brake (EPB) is used for the first time in this class of vehicle. The brake servo and pedal assembly are new developments. The Audi A3 '13 is the first Audi to be equipped with Continental's ESP MK100 brake system.

Continental ESP MK 100



15 or 17 inch wheel brakes depending on engine version

Tandem master brake cylinder with single 10" or 11" brake servo for left-hand drive models

7"/8" or 8"/8" tandem brake servo for right hand drive models

15" rear wheel brakes with electro-mechanical parking brake (EPB)

609_146

adaptive cruise control (ACC)

Overview

ACC is available as an option for the first time in this class of Audi vehicle. The customer can choose from two options:

- ▶ The "ACC" option includes a system which operates over a speed range from 30 kph to 150 kph in models with manual transmission and from 0 kph to 150 kph in models with automatic transmission.
- ▶ The optional "driver assistance package" includes an ACC system which operates over an extended speed range from 30 kph or 0 kph to 200 kph. This equipment package also includes the front camera for driver assistance systems R242.



609_147

ACC radar sensor
(ACC sender G259 and ACC control unit J428)

Design and function

There is no difference between both systems in terms of their design and general functioning. As previously in the Audi A4 '08, A5 and Q5 models, radar sensors with four transmitter and receiver units are also used in the Audi A3 '13. The ACC system in the Audi A3 '13 generally functions in the same way as the system currently used in the above-mentioned Audi models.

Additional functions

As in the A6 '11, A7 Sportback and A8 '10 models, the Audi A3 '13 also has the stop-and-go function if equipped with automatic transmission.

The prewarning and braking intervention functions featured in current Audi models under the designation "braking guard" are now incorporated into Audi pre sense.

A new safety function implemented for the first time in the Audi A3 '13 automatically brakes the vehicle in the event of an impending collision at low speeds of below 30 kph. This function is also incorporated into Audi pre sense. The measurement data obtained by the ACC system provides the basis for the identification of collision hazards. The software in the ACC control unit determines whether a collision hazard exists or not.















609_148

Wheels and tyres

Depending on equipment package, 16 and 17 inch wheels are used in the standard trim. The 17 and 18 inch wheels are optional.

The range of tyres extends from the 205/60 R16 to the 225/40 R18. The "Tyre Mobility System" is standard equipment; a minispare wheel is optional.

| | | | |
|-------------------|---|--|---|
| Attraction |  |  |  |
| | 1 | 5 | 9 |
| Ambiente |  |  |  |
| | 2 | 6 | 10 |
| Ambition |  |  |  |
| | 3 | 7 | 11 |
| S line |  |  |  |
| | 4 | 8 | 12 |
| | Standard wheels | Optional wheels | Winter wheels |
| | 6.5J x 16 ET46 Steel wheel 205/55 R16 | 1 6.5J x 16 ET46 Light alloy wheel 205/55 R16 | 5 6.5J x 16 ET48 Steel wheel snow chain compatible 205/55 R16 |
| | 7.0J x 16 ET48 Light alloy wheel 205/55 R16 | 2 7.0J x 17 ET51 Light alloy wheel 225/45 R17 | 6 7.0J x 16 ET48 Light alloy wheel 205/55 R16 |
| | 7.5J x 17 ET51 Light alloy wheel 225/45 R17 | 3 7.5J x 17 ET51 Light alloy wheel 225/45 R17 | 7 6.0J x 17 ET48 Light alloy wheel snow chain compatible 205/50 R17 |
| | 7.5J x 18 ET51 Light alloy wheel 225/40 R18 | 4 7.5J x 18 ET51 Light alloy wheel 225/40 R18 | 8 7.5J x 18 ET51 Flow-formed wheel 225/40 R18 |

Tyre pressure indicator

609_171

The Audi A3 '13 is also offered with the well-known second-generation tyre pressure indicator. This system is identical to the systems currently in use on other Audi models in terms of its design, function, operation, driver information, service operations and diagnostics.

Electrical system

Audi drive select

The Audi A3 '13 is equipped with the Audi drive select system. The customer can choose between four operating modes: efficiency, comfort, auto and dynamic. The efficiency mode configures the vehicle for fuel efficiency and helps the driver to conserve fuel. In addition, the vehicle set-up can be custom configured in individual mode.

Functional features:

- ▶ The mode previously selected is restored when the vehicle restarts.
- ▶ The settings in individual mode are automatically assigned to the vehicle key in use.
- ▶ The mode can be changed when the vehicle is stationary or while driving (requirement: terminal 15 "on").
- ▶ To active the newly selected mode for the engine too, the accelerator must be briefly moved into the idle position.
- ▶ In models with manual transmission, an E is additionally displayed on the gearshift indicator in efficiency mode.
- ▶ In models with automatic transmission, selector lever position E is automatically displayed in selector lever position D in efficiency mode.

Depending on which infotainment systems are fitted, the Audi drive select system can be configured either using a button in the centre console or via the Car menu in the MMI.

The selected mode of the Audi drive select system is displayed in the instrument cluster in the Audi radio version. In the MMI versions, the mode can additionally be indicated in the MMI display.

Equipment-dependent special features:

- ▶ The efficiency mode is only available in engine versions developing over 200 Nm of torque.
- ▶ The efficiency mode is unavailable in trailer mode.
- ▶ individual mode is only available with infotainment version MMI Radio or MMI Navigation plus.

Controllable systems



The figure shows the systems in full specification.

609_060

Functional characteristics in models with efficiency mode

Vehicles with twin clutch gearbox

| | efficiency | | comfort | | auto | | dynamic | |
|-------------------------|-------------------|-------------------|-------------------|-------------------|-------------------|-------------------|-------------------|-------------------|
| Selector lever position | D | S | D | S | D | S | D | S |
| Engine | | | | | | | | |
| Power/torque | reduced | normal | normal | normal | normal | normal | normal | normal |
| Load change | balanced | sparty | balanced | sparty | balanced | sparty | balanced | sparty |
| Accelerator pedal | balanced | sparty | balanced | sparty | balanced | sparty | balanced | sparty |
| Gearbox | | | | | | | | |
| Freewheel | active | inactive | inactive | inactive | inactive | inactive | inactive | inactive |
| Shift characteristics | "E" ¹⁾ | "S" ²⁾ | "D" ³⁾ | "S" ²⁾ | "D" ³⁾ | "S" ²⁾ | "D" ³⁾ | "S" ²⁾ |

¹⁾ optimised for fuel economy

²⁾ sparty

³⁾ balanced

Vehicles with manual gearbox

| | efficiency | | comfort | | auto | | dynamic | |
|-------------------|------------|--|----------|--|----------|--|---------|--|
| Engine | | | | | | | | |
| Upshift indicator | eco | | normal | | normal | | normal | |
| Power/torque | reduced | | normal | | normal | | normal | |
| Load change | balanced | | balanced | | balanced | | sparty | |
| Accelerator pedal | balanced | | balanced | | balanced | | sparty | |
| Gearbox | | | | | | | | |
| | — | | — | | — | | — | |

Driveline-independent vehicle systems

| | efficiency | | comfort | | auto | | dynamic | |
|---------------------------------------|-------------------------------|--|-------------|--|----------|--|--------------------------|--|
| Steering | balanced | | comfortable | | balanced | | sparty | |
| Damper control | balanced | | comfortable | | balanced | | sparty | |
| Automatic air conditioning | reduced | | normal | | normal | | normal | |
| Cornering light | eco | | comfortable | | normal | | sparty | |
| Reversible seat belt tensioner | standard | | standard | | standard | | Deployment point adapted | |
| Adaptive cruise control | optimised for fuel efficiency | | comfortable | | balanced | | sparty | |



Reference

For more detailed information about the efficiency mode, refer to Self Study Programme 486 "Audi A6 '11".

Installation locations of control units

Some of the control units shown in the overview are optional and/or country-specific equipment.

Refer to the current service literature for details of controls unit positions, as well as instructions for installation and removal.

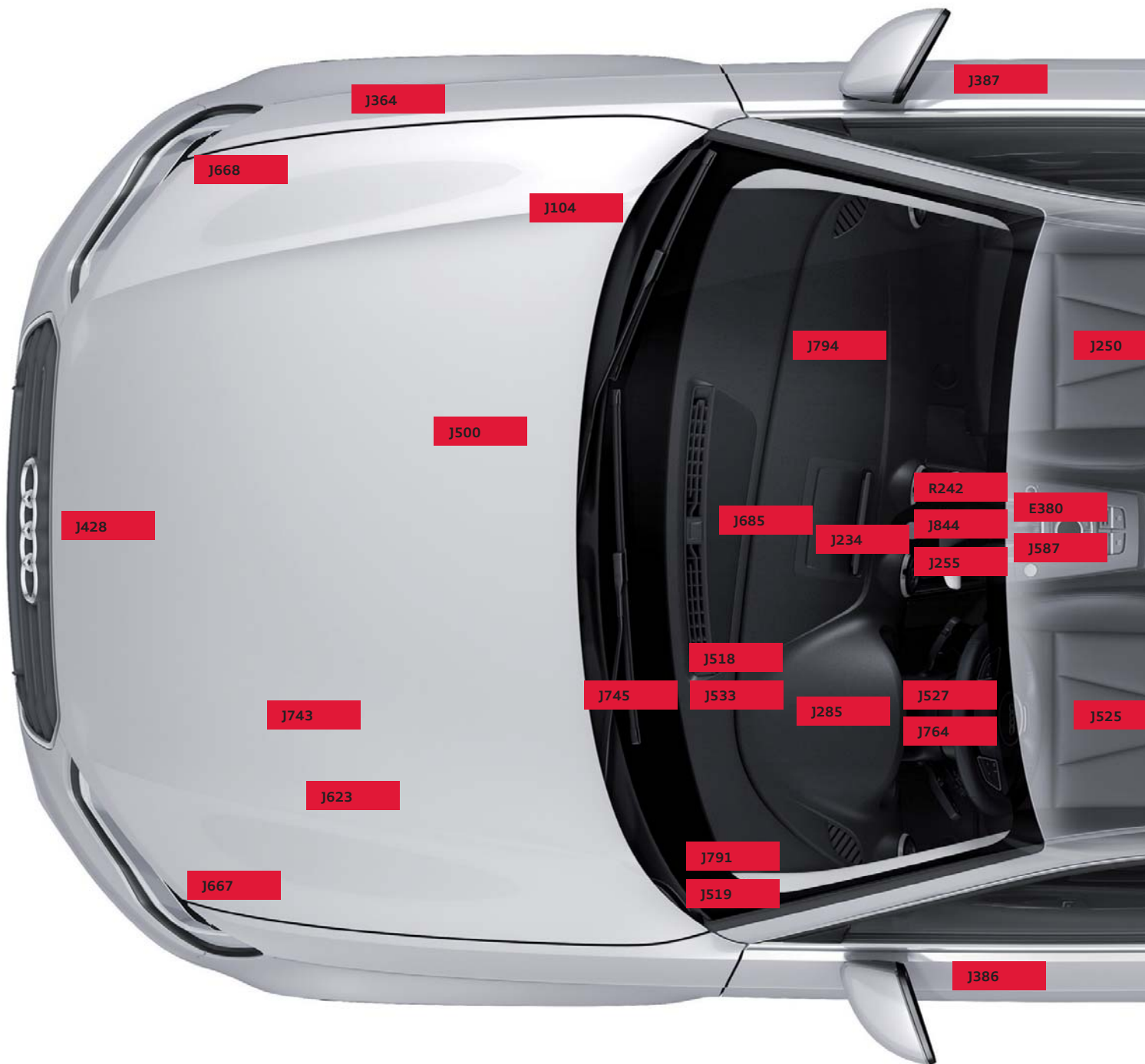

Key:

- | | |
|--|--|
| E380 Multimedia system operating unit | J428 ACC control unit |
| J104 ABS control unit | J492 All-wheel drive control unit |
| J234 Airbag control unit | J500 Power steering control unit |
| J250 ECD control unit (electronically controlled damping) | J518 Entry and start authorisation control unit |
| J255 Climatronic control unit | J519 Onboard power supply control unit |
| J285 Control unit in dash panel insert | J525 Digital sound package control unit |
| J345 Trailer detector control unit | J527 Steering column electronics control unit |
| J364 Additional heater control unit | J533 Data bus diagnostic interface |
| J386 Door control unit, driver side | J587 Selector lever sensors control unit |
| J387 Door control unit, front passenger side | J608 Special vehicle control unit |



609_153

- | | |
|--|--|
| J623 Engine control unit | J791 Audi parking system control unit |
| J667 Headlight power module, left | J794 Information electronics control unit 1 |
| J668 Headlight power module, right | J843 Vehicle tracking system interface control unit |
| J685 MMI display | J844 Headlight assist control unit |
| J743 Twin clutch gearbox mechatronics | R78 TV tuner |
| J745 Cornering light and headlight range control unit | R242 Front camera for driver assistance systems |
| J764 Electrical steering column lock control unit | |
| J769 Audi lane assist control unit | |
| J770 Audi lane assist control unit 2 | |
| J772 Reversing camera system control unit | |

Topology

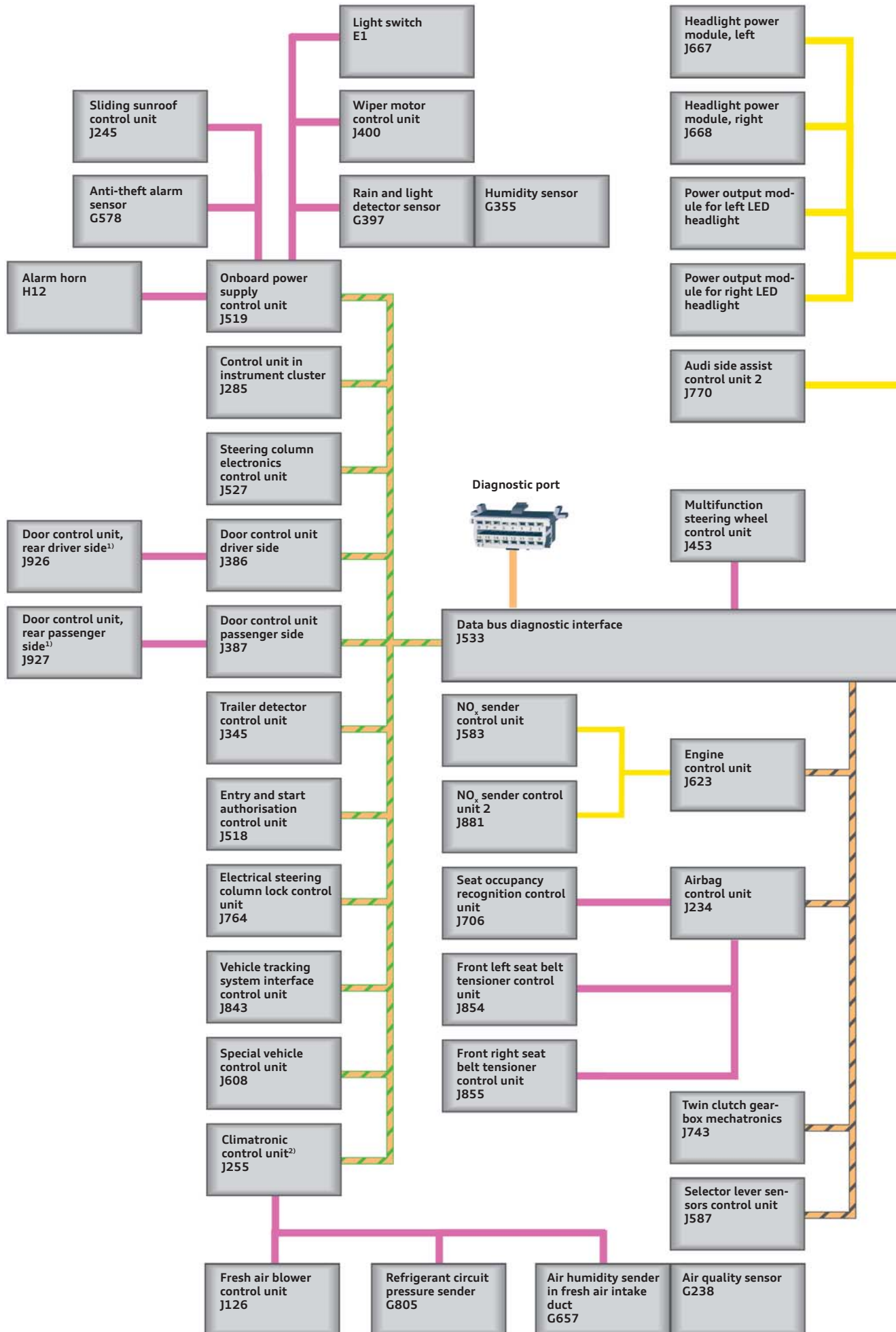





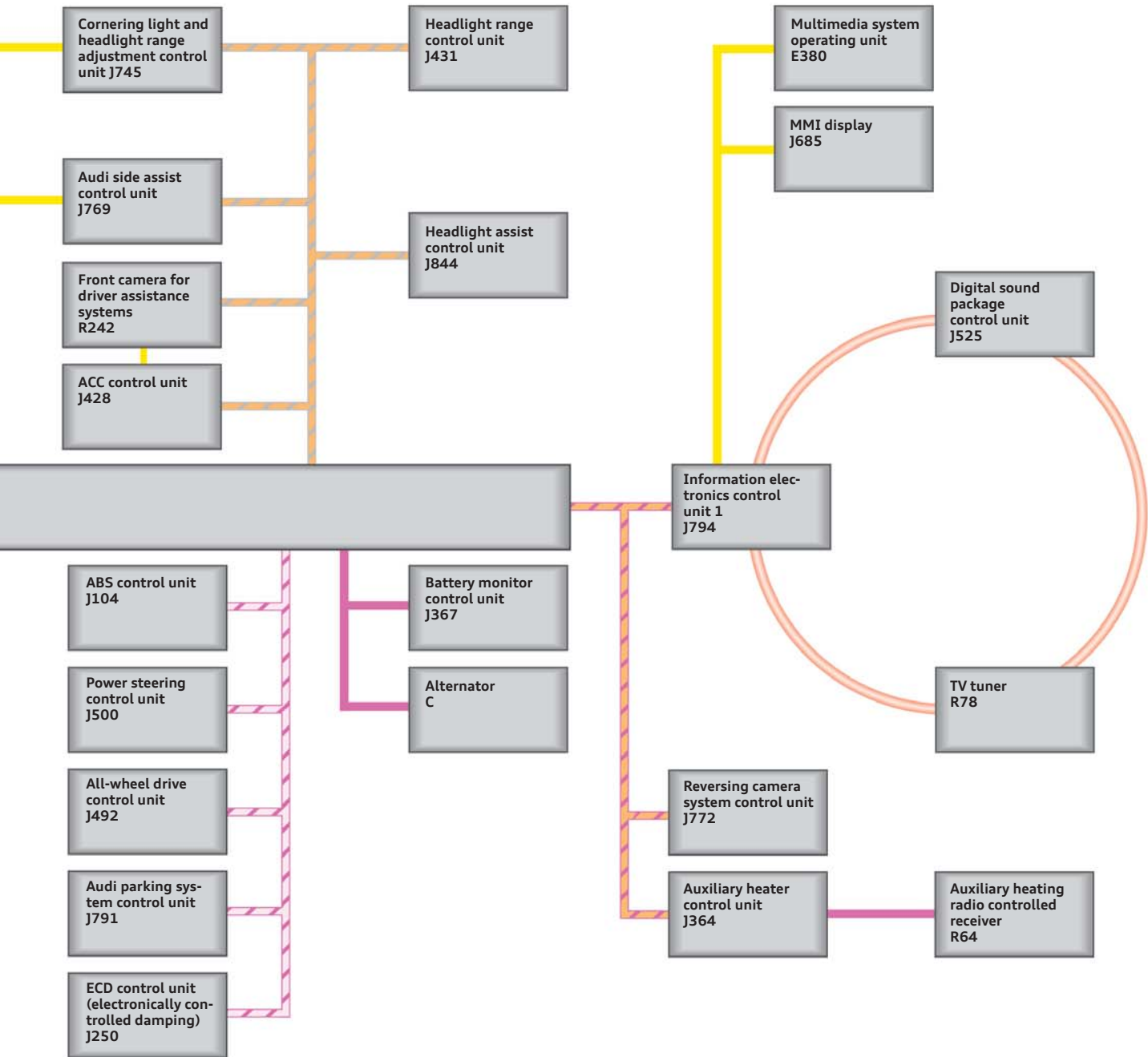



The topology shows all control units with connectivity to the data bus system. Some of the control units shown here are optional or country-specific equipment, or will be introduced at a later date.

This diagrammatic representation of all possible control units is purely theoretical. The cornering light and headlight range control unit J745, for example, is never fitted at the same time as the headlight range adjustment control unit J431, rather only one or the other.



Key:

- | | | |
|---|--|---|
|  Powertrain CAN bus |  Infotainment CAN bus |  LIN bus |
|  Convenience CAN bus |  Diagnostics CAN bus |  Sub-bus systems |
|  Extended CAN bus |  Suspension CAN bus |  MOST bus |

¹⁾ For five-door models only

²⁾ For more details of heater / air conditioning configurations, refer to SSP 609 "Audi A3 '13".

Air conditioning

Introduction

Air conditioning system versions

The Audi A3 '13 is available with different heating and air conditioning equipment:

- ▶ with a heating system only
- ▶ with a manually controlled air conditioning system
- ▶ with an automatically controlled air conditioning system

Not all three versions may necessarily be available in certain markets, depending on country specifications.

The automatic air conditioning system has a moisture and enthalpy control system. The moisture control system is used to detect windscreen fogging, and the data it provides is taken into account when calculating the stop phases in start-stop mode.

Enthalpy is a measure of the energy content in the air conditioning system. In the Audi A3 '13 efficient air conditioning is ensured by precision control of the fresh air to recirculated air ratio inside the vehicle.

In efficiency mode (Audi drive select), the air conditioning system is configured to operate at maximum energy efficiency within temperature thresholds compatible with climate comfort. To this end, the automatic air conditioning system switches to eco mode, which is indicated in the Climatronic control unit J255.

The optional auxiliary heater affords customers additional comfort. The radio remote control of the auxiliary heater allows the customer to activate the auxiliary heater using the instant start function or the timer programming function. The departure time is defined using the timer programming function. The departure time is the time at which the vehicle is expected to reach the desired temperature.

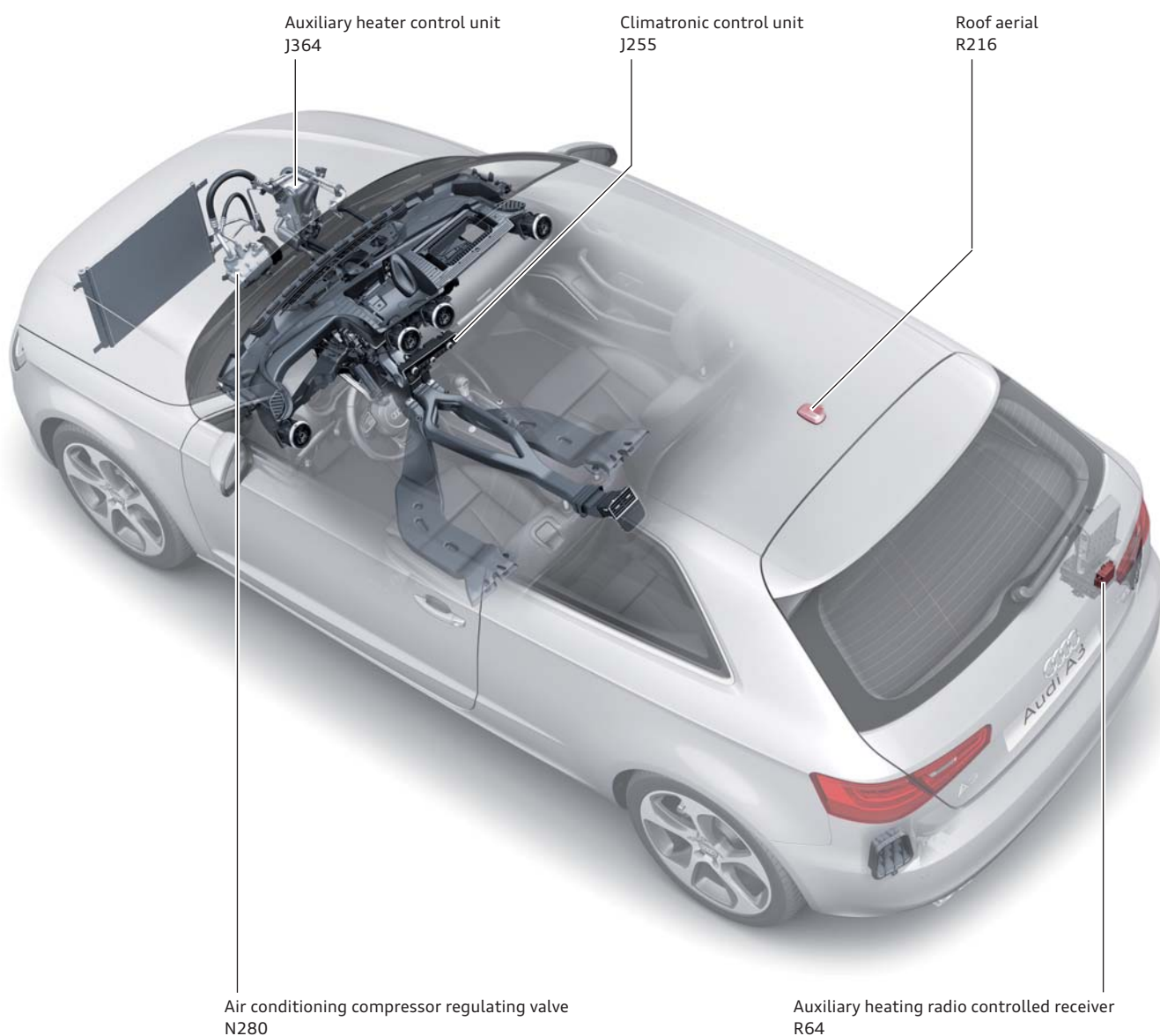

Operation

The various versions differ from one another with respect to their equipment specification. All versions are optionally available with a seat heater control button. The seat heater is a three-stage system and the selected heating level is indicated by an LED in the respective button.

As regards the operating elements, some of the rotary controls in both versions with air conditioning system have multiple functions, such as for turning cooling or automatic air conditioning ON and OFF.

The table shows an overview of the main functions of the individual versions:

| | Heater | Manual air conditioning system | Automatic air conditioning system |
|--|---|--|--|
| Control panel and control unit | Heater control unit J65 without display | Air conditioning control unit J301 without display | Climatronic control unit J255 with display |
|  | | | |
| Functions on the control panel | Three rotary controls for: <ul style="list-style-type: none"> ▶ Temperature ▶ Blower ▶ Air distribution Manual air recirculation button Heated rear window button Optional seat heater button, three-stage | Three rotary controls for: <ul style="list-style-type: none"> ▶ Temperature ▶ Blower ▶ Air distribution Manual air recirculation button Heated rear window button Optional seat heater button, three-stage AC button | Two rotary controls for drive and passenger side outlet temperature AC button AUTO button Rotary blower control Defrost button Manual air recirculation button Heated rear window button Three buttons for setting the air distribution Optional seat heater button, three-stage |
| Number of temperature zones | 1 | 1 | 2 |
| Air flow and air distribution in the occupant cell | Defroster vents Dash panel outlets, left-centre-right Footwell outlets, right/left Rear footwell outlets, right/left | Defroster vents Dash panel outlets, left-centre-right Footwell outlets, right/left Rear footwell outlets, right/left | Defroster vents Dash panel outlets, left-centre-right Footwell outlets, right/left Rear footwell outlets, right/left Rear outlets |
| Moisture and enthalpy control | no | no | • |
| AC modes | no | no | Two AC modes <ul style="list-style-type: none"> ▶ normal ▶ eco |
| Automatic air recirculation control | no | no | • |
| Air quality sensor | no | no | • |
| Sun sensor | no | no | • |
| Interior moisture sensor | no | no | • |
| Exterior moisture sensor | no | no | • |
| Glove compartment cooling | no | no | no |

Heater and air conditioner

The heaters and air conditioners are available in various versions but are identical in terms of their basic design. The heater on its own does not have any components of the refrigerant system, such as the expansion valve or the condensate drain. This is a unitary heater or air conditioner. To remove the air distributor housing from the Audi A3 '13, the heater or air conditioner must be taken out.

All versions have a dust and pollen filter. The automatic air conditioning system has an activated charcoal dust and pollen filter. In combination with the air quality sensor G238, the activated charcoal component in the filter works to reduce pollutant emissions in the fresh air inside the vehicle.

The dust and pollen filter in the Audi A3 '13 can be replaced through the open glove compartment.

Manual air conditioner

Left hand drive vehicles



Right hand drive vehicles

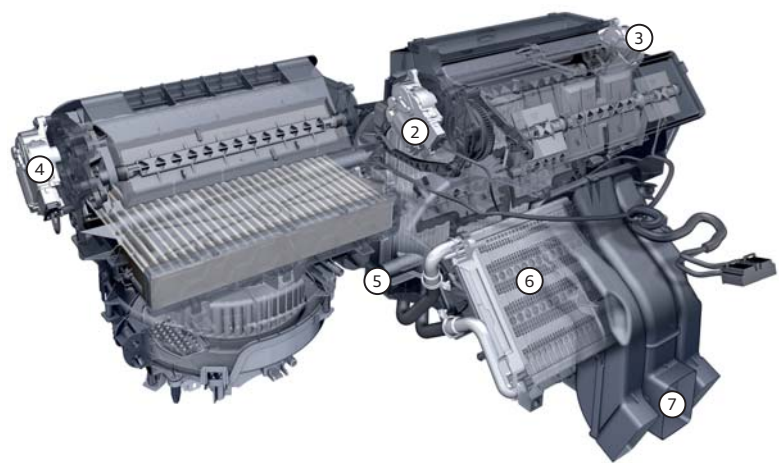

Key:

- 1 Temperature flap servomotor, left V158
- 2 Air distributor flap servomotor V428
- 3 Defroster flap servomotor V107
- 4 Air recirculation flap servomotor V113

- 5 Evaporator
- 6 Heat exchanger
- 7 Air duct for outlets in the rear centre console. Only in vehicles with automatic air conditioning system.

Basic design

The design of both air conditioners is partially mirror inverted. The position of the expansion valve is exactly the same in the left and right hand drive versions. In both versions the heat exchanger can be replaced with the air conditioner fitted. In the case of both air conditioners, the air conditioner has to be removed before the evaporator or the air distributor housing can be replaced. There are differences between left hand drive and right hand drive air conditioners, for example in regard to the procedure for removing the auxiliary heater element Z35 or the evaporator out-flow temperature sender G263.

The procedure for removing the various components is described in detail in the Heating and Air Conditioning Systems workshop manual.

The air conditioning servomotors have different actuator elements.



Note

- The arrangement of the servomotors on the heater and air conditioner is identical on left and right hand drive models.
- The mid-section of the air conditioner is identical in both versions.

Auxiliary heater

Thermo Top Evo

The Thermo Top Evo is used as an auxiliary heater in the Audi A3 '13. Thermo Top Evo is a more advanced version of Thermo Top C/Z.

Technical details:

- ▶ The heater works on the evaporator principle
- ▶ Heat output: 2.5 – 5.0 KW
- ▶ Fuel consumption: 0.6 – 0.7 l/h
- ▶ CO₂ analysis and adjustment are performed using the vehicle diagnostic tester
- ▶ Inline integration in the water circuit
- ▶ Auxiliary heating radio controlled receiver R64

The auxiliary heater is available as an optional extra for both petrol engined and diesel engined models. All diesel engined models come with an auxiliary heater element Z35 configured as an electrically assisted auxiliary heater for the occupant cell. The auxiliary heater is not presently used as a fuel operated auxiliary heater.

Installation location of the auxiliary heater in the vehicle

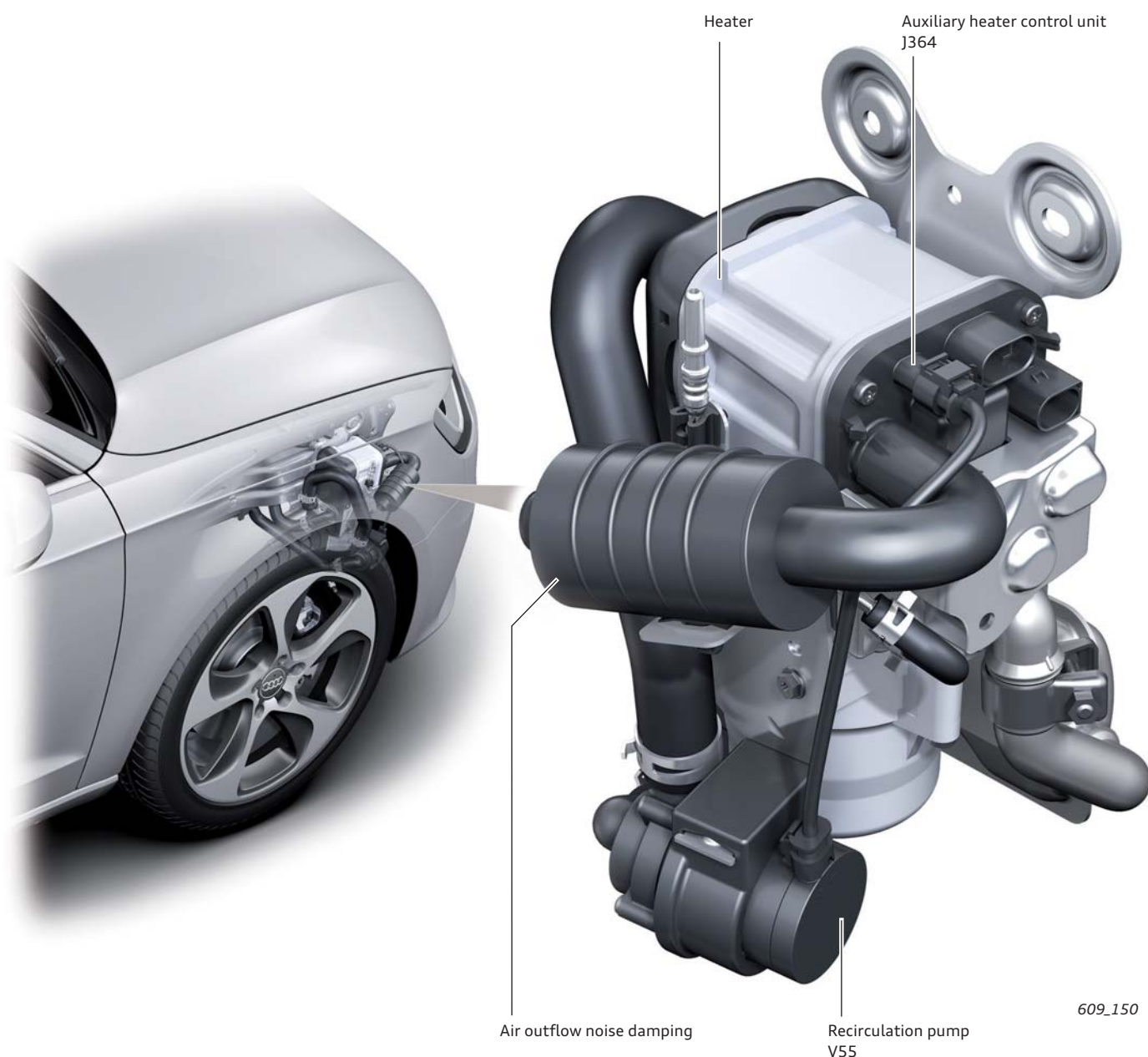

609_150

The water circuit is filled with the aid of the cooling system filling unit VAS 6096. The auxiliary heater and the recirculation pump V55 are separately post-ventilated.

A detailed description of the procedure can be found in the Auxiliary Heater workshop manual.

Design of the Thermo Top Evo auxiliary heater

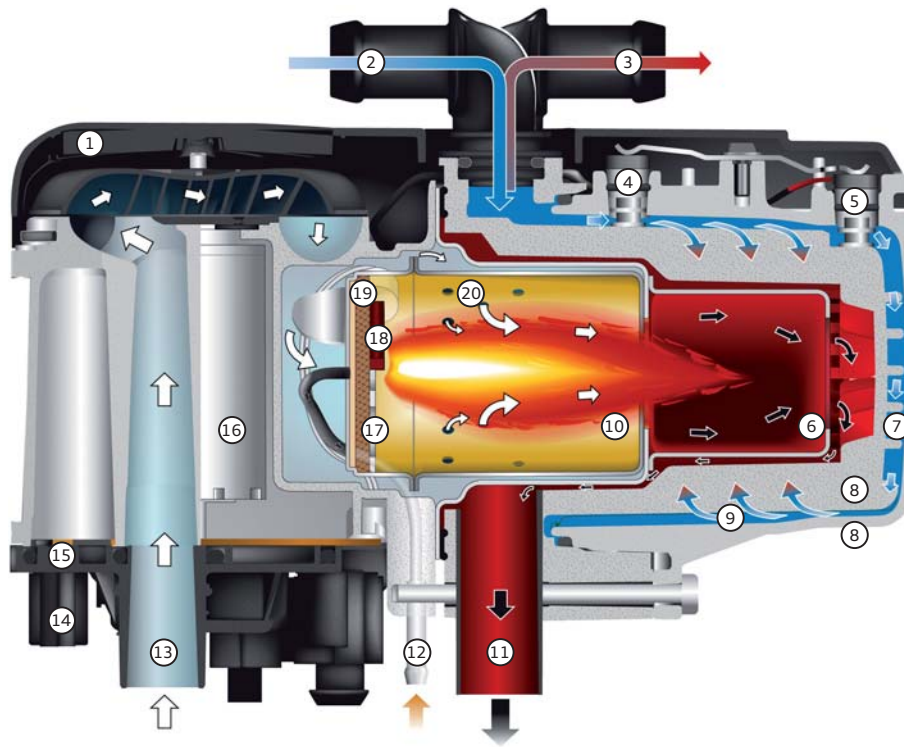

609_051

Key:

- | | | | |
|----|---------------------------------|----|-------------------------------------|
| 1 | Combustion air blower fan wheel | 11 | Exhaust outlet |
| 2 | Coolant inlet | 12 | Fuel feed line |
| 3 | Coolant outlet | 13 | Combustion air inlet |
| 4 | Temperature sensor G18 | 14 | Electrical connections |
| 5 | Overheating sensor G189 | 15 | Additional heater control unit J364 |
| 6 | Flame pipe | 16 | Combustion air blower V6 |
| 7 | Ribbing | 17 | Locking plate |
| 8 | Heat exchanger | 18 | Glowplug with flame monitor |
| 9 | Water jacket | 19 | Metal fleece |
| 10 | Combustion chamber | 20 | Combustion air intake ports |

Radio remote control

Unlike the well-known radio remote controls in the Audi A6 '11 / A7 Sportback and A8 '10 models, the radio remote control of the Audi A3 '13 offers added user convenience. It is now possible to simultaneously activate the instant start and timer programming functions. A new feature is the modified display. For easy identification by the customer, the radio remote control of the Audi A3 '13 is now indicated by a white font on a black background.

The Audi A3 '13 uses a modified auxiliary heating radio controlled receiver R64. This means that the handheld receivers are incompatible with the auxiliary heater receivers of the Audi A6 '11, A7 Sportback and A8 '10.

For further information, refer to SSP 484 "Audi A7 Sportback – Occupant Protection, Infotainment and Air Conditioning".



609_158

Integration of the auxiliary heater in the cooling system

Temperatures in the auxiliary heater circuit
(shown using 2.0l TDI engine EA288 as an example)

█ Cooled coolant
█ Heated coolant

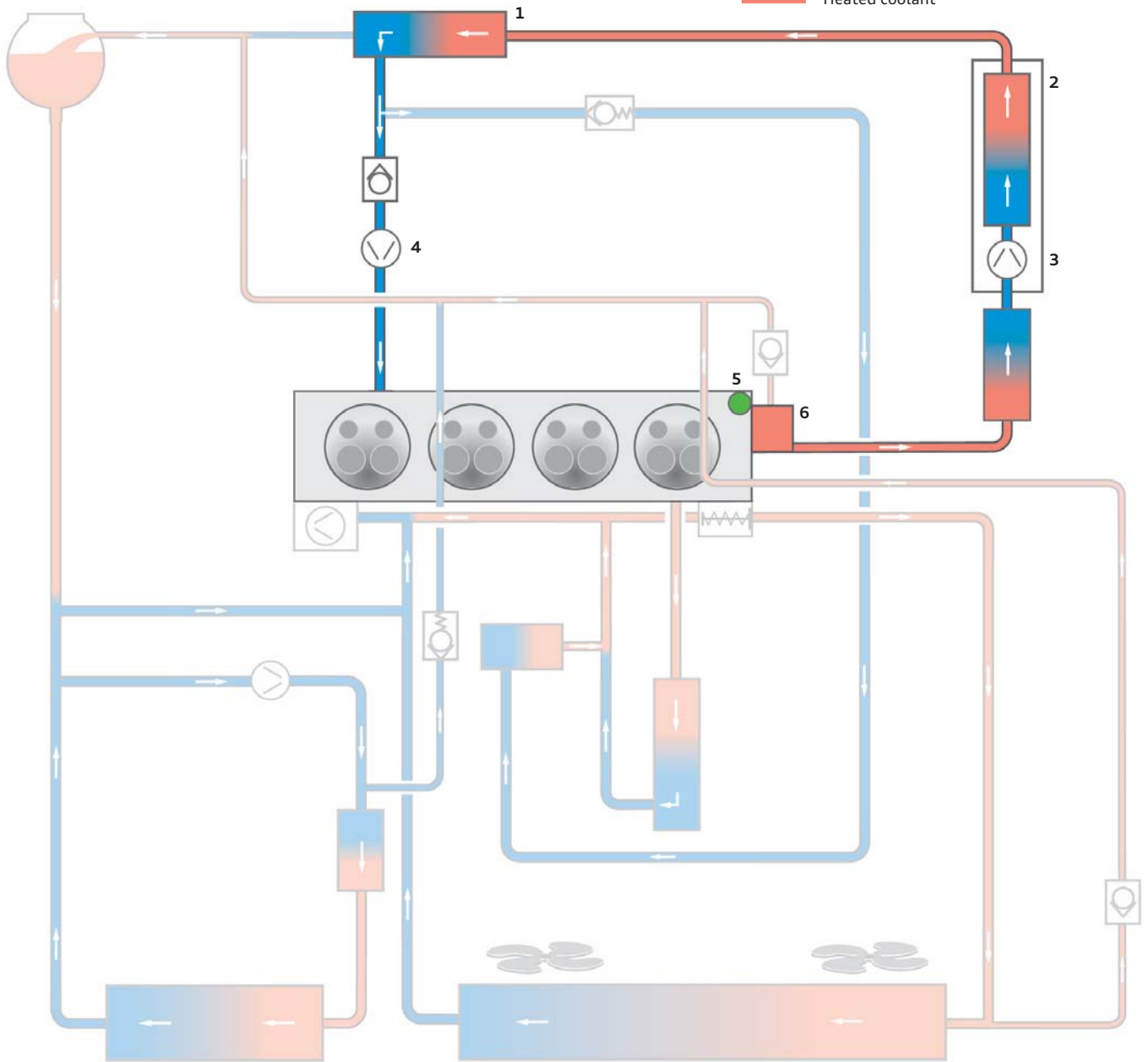

609_128

Key:

- | | |
|--|---|
| <p>1 Heater heat exchanger</p> <p>2 Auxiliary heater</p> <p>3 Recirculation pump V55</p> | <p>4 Heating assistance pump V488</p> <p>5 Coolant temperature sender G62</p> <p>6 Coolant socket</p> |
|--|---|

The auxiliary heater is integrated directly in the heat exchanger inlet. The overview diagram above shows the coolant circuit of a diesel engine. The secondary coolant circuit begins at the auxiliary heater, which directly supplies the heat exchanger in the vehicle interior with the aid of the circulation pump V55. The coolant then flows back towards the engine and passes the heating assistance pump V488. After flowing through the engine, the coolant heats up the exhaust recirculation cooler and then returns to the auxiliary heater.

The heating assistance pump V488 can be used in diesel engines.

The petrol and diesel engines have different coolant circuits. For example, the exhaust turbocharger can be integrated in the secondary coolant circuit or the coolant shutoff valve N82 in the infeed line to the heat exchanger.

Connected components

Heating and ventilation system

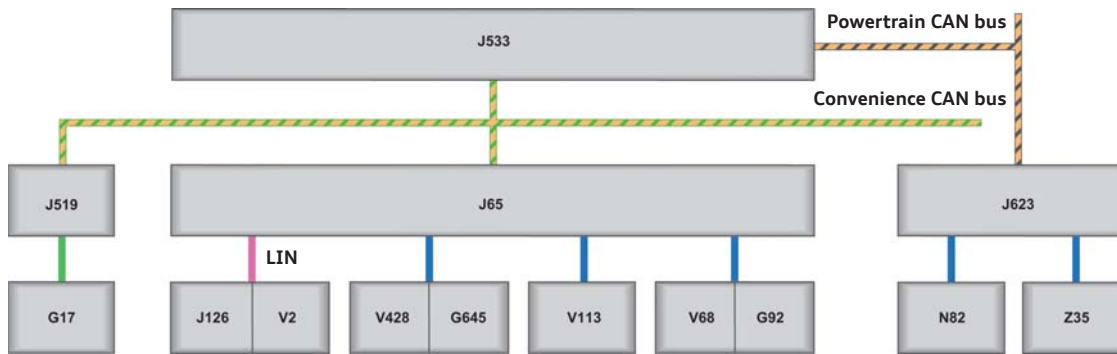

609_030

In all versions and in the heating and ventilation system, the fresh air blower control unit is a LIN bus user of the relevant heater and air conditioner.

All servomotors are connected directly to the heater control unit J65. The heater control unit J65 participates in communication with other control units via the convenience CAN bus.

Manual air conditioning system

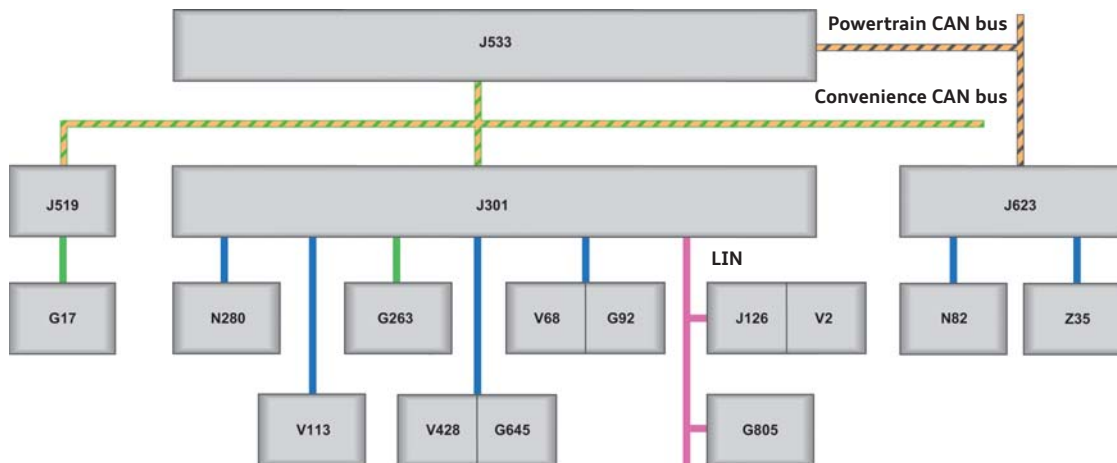

609_031

The air conditioning system control unit J301 also has at its disposal sensors and actuators from the refrigerant circuit, in addition to the "pure" heating system. The refrigerant circuit pressure sender G608 communicates with the air conditioning system control unit J301 by LIN bus.

Depending on engine type, all three versions can have a coolant shutoff valve N82 or an auxiliary heater element Z35.

Automatic climate control

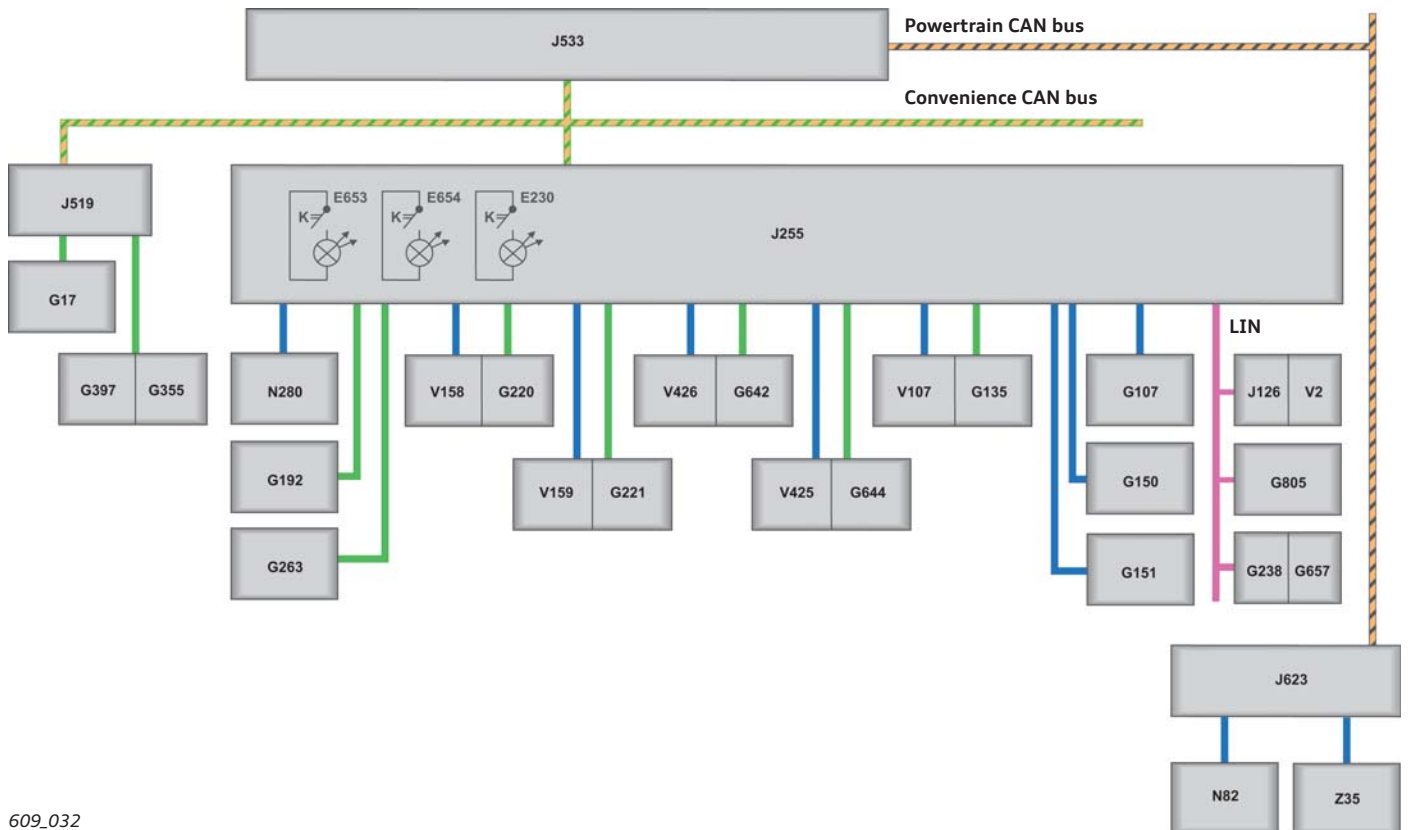

609_032

In order to control the enthalpy of the air conditioning system, the Climatronic control unit J255 requires additional information on relative humidity as well as the cabin air and the ambient air.

For this purpose, the humidity sender G355 supplies cabin air data to the Climatronic control unit J255 via the convenience CAN bus. Ambient air humidity data is sent by LIN signal directly to the Climatronic control unit J255 from the air humidity sensor in the fresh air duct G657.

Key to figures on pages 70 and 71:

E230 Heated rear window button
 E653 Seat heater button, left
 E654 Seat heater button, right

G17 Ambient temperature sensor
 G92 Temperature flap servomotor potentiometer
 G107 Sunlight photosensor
 G135 Defroster flap servomotor potentiometer
 G150 Left vent temperature sender
 G151 Right vent temperature sender
 G192 Footwell vent temperature sender
 G220 Left temperature flap servomotor potentiometer
 G221 Right temperature flap servomotor potentiometer
 G238 Air quality sensor
 G263 Evaporator outlet temperature sender
 G355 Humidity sender
 G397 Rain and light detector sensor
 G642 Front air distributor flap servomotor potentiometer
 G644 Fresh air/air circulation and air flow flap servomotor potentiometer
 G645 Air distributor flap servomotor potentiometer
 G657 Air humidity sender in fresh air intake duct
 G805 Refrigerant circuit pressure sender

J65 Heater control unit
 J126 Fresh air blower control unit
 J255 Climatronic control unit
 J301 Air conditioning system control unit
 J519 Onboard power supply control unit
 J533 Data bus diagnostic interface
 J623 Engine control unit

N82 Coolant shutoff valve
 N280 Air conditioning compressor regulating valve
 V2 Fresh air blower
 V68 Temperature flap servomotor
 V107 Defroster flap servomotor
 V113 Air recirculation flap control motor
 V158 Left footwell flap control motor
 V159 Right temperature flap control motor
 V425 Fresh air/air circulation and air flow flap servomotor
 V426 Front air distributor flap servomotor
 V428 Air distributor flap servomotor
 Z35 Auxiliary heater element (in diesel engine models)

Infotainment

The Audi A3 '13 is the first model to be provided with hardware of the infotainment platform with the designation Modular Infotainment Platform (MIP for short).

The Modular Infotainment Platform is yet another milestone of the Volkswagen Group. In future, the Modular Infotainment Platform will replace all previous infotainment systems. In all, there will be three expansion levels of the MIP: MIP Entry, MIP Standard and MIP High. The new platform allows the same CPU (infotainment electronics control unit 1 J794) to be used Group-wide. For differentiation purposes, however, the user interface and the controls are adapted for each brand.

The Modular Infotainment Platform comes as standard with an infotainment CAN bus and can also have a MOST bus if optional equipment is fitted. In the future, image data from TV tuners and DVD changers will be sent via MOST bus.

The infotainment system in the Audi A3 '13 features classic Audi styling and an advanced operating logic.

Overview of versions

Three basic versions are available in the Audi A3 '13: Audi Radio, MMI Radio and MMI Navigation plus. From a technical point of view, however, three different versions of the MMI Radio are fitted. These are: MIB Entry plus, MIB Standard and MIB Standard with navigation function. The version behind the term Audi Radio is MIP Entry. Once again, the term MMI Navigation plus denotes the highest expansion level, i.e. MIP High.

The technical details of the individual expansion levels of the Modular Infotainment Platform are briefly explained on the following pages.

Depending on market, the Audi A3 '13 will also be available with Audi connect including a car phone at a later date. This means that Audi connect services can also be used in the Audi A3 '13.

The following table shows the main equipment features and optional equipment.

Audi Radio (Europe only)

MMI Radio



Basic equipment

3.4" monochrome display with 270 x 94 pixel resolution

5.8" TFT colour monitor with 400 x 240 pixel resolution

AM/FM radio with phase diversity

AM/FM radio with phase diversity

Car configuration via Setup

Car menu

CD drive (MP3, WMA)

CD drive (MP3, WMA, AAC¹⁾)

1 SD card reader (SDHC cards w 32 GB of memory)

AUX In socket

AUX In socket

Basic sound system (2 x 20 watts) (8RE)

Basic Plus sound system (4 x 20 (8RM)

Options







Bluetooth interface for HFP and (9ZX) and speech dialogue system

Audi music interface (UE7)

Universal Mobile Phone Preparation (Audi phone box) for HFP and A (9ZE)

Digital radio DAB or SDARS (QV3)

Audi Sound System (9VD)

| | MMI Radio with Connectivity Package | MMI Radio with Navigation Package | MMI Navigation plus |
|---------------|---|--|---|
| |  |  |  |
| |  |  |  |
| | 5.8" TFT colour monitor with 400 x 240 pixel resolution | 5.8" TFT colour monitor with 400 x 240 pixel resolution | 7.0" TFT colour monitor with 800 x 480 pixel resolution |
| | Prewired for navigation | 2D navigation system with SD card | 3D hard drive navigation system |
| | | | MMI touch |
| ty | AM/FM radio with phase diversity and TMC tuner | AM/FM radio with phase diversity and TMC tuner | AM/FM radio with phase diversity and background tuner |
| | Car menu | Car menu | Car menu |
| | CD drive (MP3, WMA, AAC) | CD drive (MP3, WMA, AAC) | DVD drive (audio/video, MP3, AAC, WMA, MPEG4) |
| with up to | 2 SD card readers (SDHC cards with up to 32 GB of memory) | 2 SD card readers (SDHC cards with up to 32 GB of memory) | 2 SD card readers (SDHC cards with up to 32 GB of memory) |
| | | | approx. 10 GB for jukebox |
| | Audi music interface (UE7) | Audi music interface (UE7) | Audi music interface (UE7) |
| 0 watts) | Basic Plus sound system (4 x 20 watts) (8RM) | Basic Plus sound system (4 x 20 watts) (8RM) | Basic Plus sound system (4 x 20 watts) (8RM) |
| | Bluetooth interface for HFP and A2DP (9ZX) | Bluetooth interface for HFP and A2DP (9ZX) | Bluetooth interface for HFP and A2DP (9ZX) |
| | Speech dialogue system | Speech dialogue system | Premium speech dialogue system |
| A2DP em | | | |
| tion UHV A2DP | Universal Mobile Phone Preparation UHV (Audi phone box) for HFP and A2DP (9ZE) | Universal Mobile Phone Preparation UHV (Audi phone box) for HFP and A2DP (9ZE) | Universal Mobile Phone Preparation UHV (Audi phone box) for HFP and A2DP (9ZE) |
| | | | Bluetooth car phone BTA (market-dependent, Audi connect incl. car phone) (9ZK) |
| | Digital radio DAB (QV3) | Digital radio DAB (QV3) | Digital radio DAB or SDARS (QV3) |
| | Audi Sound System (9VD) | Audi Sound System (9VD) | Audi Sound System (9VD) |
| | Bang & Olufsen Sound System (9VS) | Bang & Olufsen Sound System (9VS) | Bang & Olufsen Sound System (9VS) |

¹⁾ The MMI Radio can only play back AAC files if optional equipment is fitted.

Modular Infotainment Platform (MIP)

Introduction

The name Modular Infotainment Platform in itself is indicative of the process of standardisation which the very different systems previously used within the Volkswagen Group has undergone. The MIP is modular in design so that brand-specific versions can be offered on four standardised hardware platforms.

Three versions are used in the Audi A3 '13:

- ▶ MIP Entry/Entry plus
- ▶ MIP Standard
- ▶ MIP High

A Group brand is responsible for each of these expansion levels. AUDI AG is responsible for the development of MIP High, Volkswagen for MIP Standard and Škoda for MIP Entry.

Each version of the MIP has a central control unit - the information electronics control unit 1 J794. It is always installed in the glove compartment in the Audi A3 '13.

Depending on version, the information electronics control unit 1 J794 combines the following control units and functions:

- ▶ Infotainment system master
- ▶ CD or DVD drive
- ▶ Radio
- ▶ Digital radio (DAB or SDARS)
- ▶ Audio amplifier (up to 180 watts)
- ▶ Up to two SD card readers
- ▶ Bluetooth interface (HFP and A2DP plus SAP with Bluetooth car phone)
- ▶ Telephone module with SIM card reader
- ▶ Navigation
- ▶ Non-volatile memory (approx. 60 GB)
- ▶ Voice control
- ▶ System and diagnostic master for MOST bus



J794 of MIP Entry

609_084



J794 of MIP Entry plus

609_085



Front of MIP Standard
radio version

609_086



Front of MIP Standard
navigation version

609_087



Front of MIP High
with Bluetooth car phone

609_088



Reference

For further information about the Modular Infotainment Platform, refer to Self Study Programme 618 "Audi Modular Infotainment Platform".

Networking

The information electronics control unit 1 J794 is connected to the data bus diagnostic interface J533 via the infotainment CAN bus in all versions of the MIP. The infotainment CAN bus is a highspeed bus with a data transfer rate of 500 kbit/s.

The MMI display J685 and the operating unit E380 are connected to the information electronics control unit 1 J794 via a private CAN bus for the first time. This bus is also a highspeed bus with 500 kbit/s.

If the vehicle is fitted with an additional infotainment control unit, such as the Bang & Olufsen audio amplifier, the system also comes with a MOST bus. Thus, for the first time, both the infotainment CAN bus and the MOST bus can be simultaneously integrated in a vehicle.

The MOST bus is a so-called "MOST150" with a data transfer rate of 150 Mbit/s. The information electronics control unit 1 J794 acts both as the system master and as the diagnostics master for the MOST bus.

Due to the combination of infotainment CAN bus and MOST bus, an open circuit in the MOST bus will not result in total failure of the MMI. All functions which are executed directly in J794 therefore remain available. However, audio would no longer be output via an external amplifier.

As an option, the reversing camera system control unit J772 and the additional heater control unit J364 can be connected to the infotainment CAN bus of the Audi A3 '13.

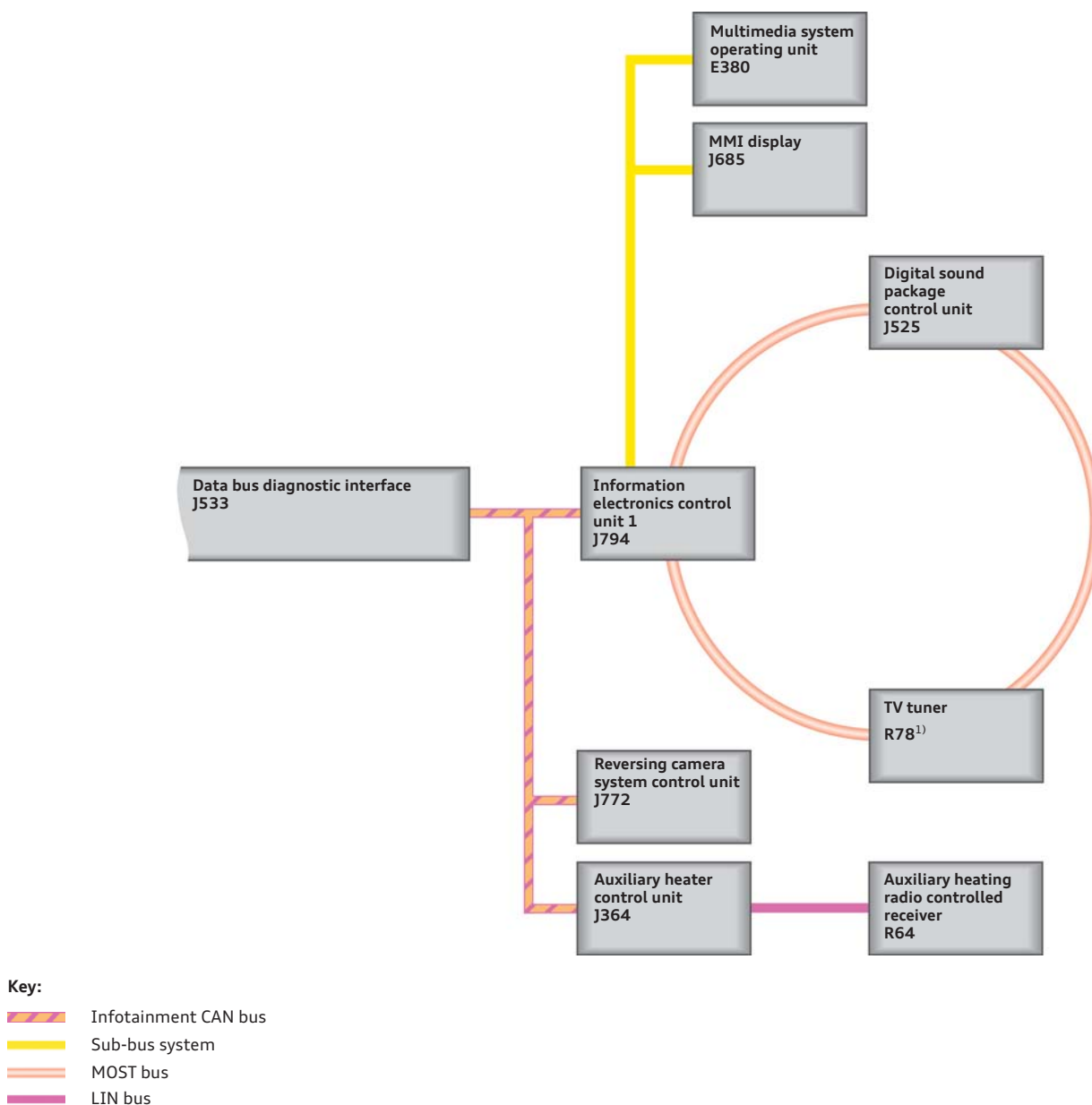

609_123

¹⁾ TV is available in Japan only

MIP Entry and Entry plus (available in Europe only)

MIP Entry is the entry-level infotainment system. In the Audi A3 '13 it is referred to as Audi Radio. The information electronics control unit 1 J794 is located in the glove compartment, as in all MIP versions. MIP Entry is operated via the operating unit E380 mounted on the dash panel, in which the display unit is also integrated. No optional equipment is available with MIP Entry.

MIP Entry has the following features:

- ▶ Radio with phase diversity for FM (very high frequency) and AM (medium wave)
- ▶ A single CD drive which supports MP3 and WMA files
- ▶ Integrated amplifier with 4 x 20 watts max. power
- ▶ AUX In socket
- ▶ Car configuration via Setup button
- ▶ All-in-one display and operating unit

The operating unit E380 mounted on the dash panel is equipped with a 3.4" monochrome display. The operating unit is mechanically retractable. When the display is fully retracted, the buttons for media operation and volume control can still be operated.

If customers require a radio with a large MMI display and a remote control panel, they have the option of ordering MMI Radio. The system in question is MIP Entry plus.

MIP Entry plus has the following additional features not available in MIP Entry:

- ▶ An SD card reader for MP3 and WMA files
- ▶ An electrically retractable 5.8" TFT screen
- ▶ A remote control panel in the centre console

Both a monochrome and colour driver information system and a multifunction steering wheel are optionally available with MIP Entry plus.



Front of MIP Entry
(Audi Radio)

609_084



Back of MIP Entry
(Audi Radio)

609_089



Display and operating unit of MIP Entry
(Audi Radio)

609_090



Front of MIP Entry plus
(MMI Radio)

609_085



Back of MIP Entry plus
(MMI Radio)

609_091

MIP Standard

There are radio and navigation versions of MIP Standard. In the Audi A3 '13 the versions always have the designation MMI Radio. The information electronics control unit 1 J794 in MIB Standard always has a MOST bus connection. If no optional equipment requiring a MOST bus is fitted, the MOST bus connection is unasigned.

The radio version of MIP Standard has the following features:

- ▶ Radio with phase diversity, FM dual tuner (very high frequency) and AM tuner (medium wave)
- ▶ A single CD drive for MP3, WMA and AAC files
- ▶ An SD card reader for MP3, WMA and AAC files
- ▶ Integrated amplifier with 4 x 20 watts max. power
- ▶ AUX In socket
- ▶ Car menu
- ▶ An electrically retractable 5.8" TFT screen
- ▶ A remote control panel in the centre console

It is optionally available with the following features:

- ▶ DAB tuner (digital radio) (QV3)
- ▶ SDARS tuner (NAR spec digital radio) (QV3)
- ▶ Internal amplifier for Audi sound system with 180 watts max. power (8VD)
- ▶ Audi music interface (UE7)
- ▶ Bluetooth interface for HFP and A2DP (9ZX)
- ▶ Universal Mobile Phone Preparation (9ZE)
- ▶ Speech dialogue system
- ▶ Bang & Olufsen Sound System with 705 watts max. power (9VS)

If MMI Radio is prewired for navigation, it has the following additional features:

- ▶ Second SD card reader
- ▶ Navigation hardware

If the navigation function of the MMI Radio is activated ex works, the navigation map data is stored on an SD card in the vehicle.



Front of MIP Standard radio version (MMI Radio)

609_086



Back of MIP Standard radio version (MMI Radio)

609_092



Front of MIP Standard navigation version (MMI Radio)

609_087

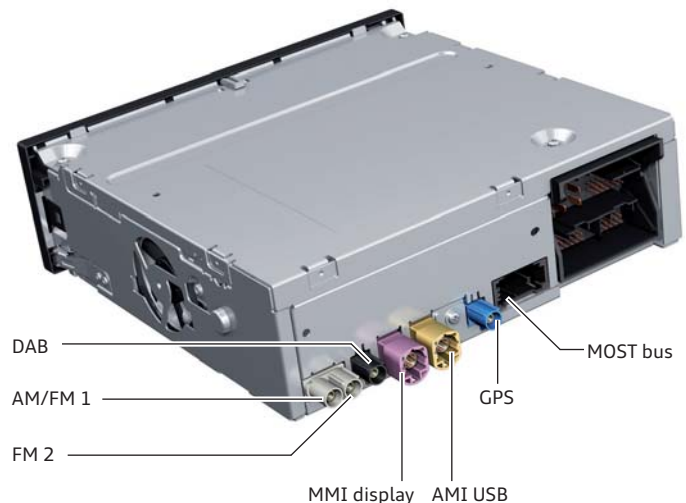

Back of MIP Standard navigation version (MMI Radio)

609_093

MIP High

The MIB High in the Audi A3 '13 has the designation MMI Navigation plus. The information electronics control unit 1 J794 in MIB High always has a MOST bus connection. If no optional equipment requiring a MOST bus is fitted, the MOST bus connection is unassigned.

The MIB High is a logical progression from the 3rd generation plus MMI with a new 3D screen display and an SSD non-volatile memory¹⁾.

MIP High has the following features:

- ▶ Radio with phase diversity, FM dual tuner (very high frequency) and AM tuner (medium wave)
- ▶ Single DVD drive for audio and video files
- ▶ Two SD card readers for audio and video files
- ▶ SSD non-volatile memory (approx. 60 GB, of which approx. 10 GB for jukebox)
- ▶ 3D navigation with navigation data on non-volatile memory
- ▶ Integrated amplifier with 4 x 20 watts max. power
- ▶ Audi music interface
- ▶ Car menu
- ▶ Bluetooth interface for HFP and A2DP
- ▶ Premium speech dialogue system
- ▶ Provision of predictive route data
- ▶ An electrically retractable 7.0" TFT screen
- ▶ Remote control panel in centre console with MMI touch

MMI High is optionally available with the following features:

- ▶ Universal Mobile Phone Preparation (9ZE)
- ▶ Bluetooth car phone; marketdependent, Audi connect incl. car phone (9ZK)
- ▶ DAB tuner (digital radio) (QV3)
- ▶ SDARS tuner (NAR spec digital radio) (QV3)
- ▶ Internal amplifier for Audi sound system with 180 watts max. power (8VD)
- ▶ Bang & Olufsen Sound System with 705 watts max. power (9VS)

If MIB High is equipped with Audi connect including car phone, it has Audi connect.



Front of MIB High
(MMI Navigation plus)

609_124



Back of MIB High
(MMI Navigation plus)

609_094



Front of MIB High with Bluetooth car phone
(MMI Navigation plus)

609_088

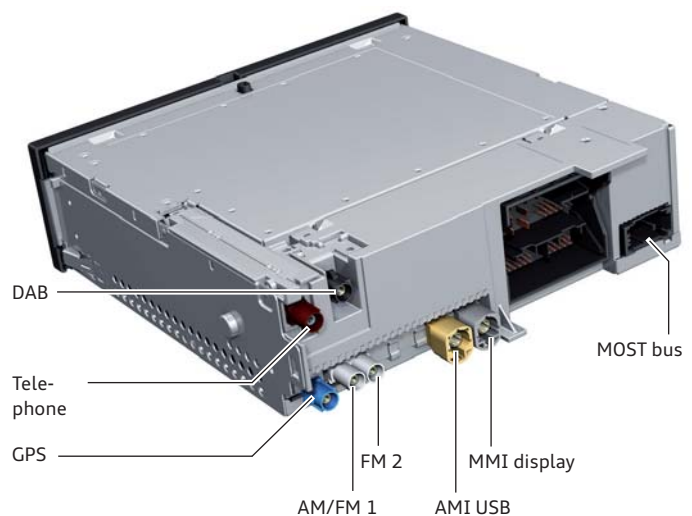

Back of MIB High with Bluetooth car phone
(MMI Navigation plus)

609_095

¹⁾ SSD (Solid State Drive) non-volatile memory

Audi connect (market dependent)

The term Audi connect stands for networked mobility. It combines applications and developments which allow media to be used in the vehicle and to be connected to the outside world.

Audi connect also includes the Audi Online Services which were introduced in the Audi A8 '10.

Audi connect can be used whenever the vehicle is equipped with Audi Navigation plus with Bluetooth car phone online. Audi connect services and applications can vary from market to market.

In the Audi A3 '13, new services will be available in addition to the existing Audi connect services.

Previous services and functions include:

- ▶ Audi traffic information online
- ▶ Google Earth
- ▶ WLAN hotspot

New services include:

- ▶ Facebook
- ▶ Twitter

Several services, such as "Google Earth", are already activated and ready for use on delivery of the vehicle. Other services, such as "Facebook", can only be used after they have been activated via "myAudi". For this purpose, customers must register online at "myAudi". Customers can then configure their vehicle here. If the configured vehicle meets the requirements for Audi connect, additional services available for this vehicle can also be activated.

Audi connect also includes smartphone applications such as "Audi music stream".



Audi connect – Google Earth

609_096



Audi connect – activated additional services

609_097



Reference

For information on previous Audi connect services (previously referred to as Audi Online Services), refer to Self Study Programme 456 "Audi A8 '10" as well as SSP 484 "Audi A7 Sportback – Occupant Protection, Infotainment and Air Conditioning" and SSP 603 "Audi A6 Avant '12".

Various Service TV broadcasts on the topic of Audi connect have been published at Audi Training Online (ATO). Among others, the programme "Audi Online Services and myAudi" appeared in January 2010, two programmes on "Audi Traffic Information online" in July 2011 and the programme "Audi music stream" in May 2012.

Components in the Audi A3 '13

Operating unit

(multimedia system operating unit E380)

Two versions of the multimedia system operating unit E380 are installed in the Audi A3 '13. To allow even more intuitive operation, the number of buttons on the operating units was optimised compared to the previous systems. There are now two toggle buttons which can be used to select between two menus.

The volume control also tilts to the left and right. It can be used for example to move backwards and forwards between tracks in the music menu.

Two versions are installed for the MMI Radio versions. Technically, they are identical and differ only in terms of the menu options available with the left toggle button. The third version additionally has MMI touch.

In the basic version, the left toggle button can be used to activate the following menus:

- ▶ Tone
- ▶ Car

The next version comes into effect if an MMI Radio with a hands-free, telephone or navigation function is fitted. The following menus can be activated with the left toggle button:

- ▶ Telephone
- ▶ Navigation

The third version with MMI touch is fitted in combination with MMI Navigation plus. With this version also, the left toggle button is used to select between telephone and navigation. In this case, however, the turn-push button is slightly larger than in the other versions.

The touch sensitive input field is integrated in the turn-push button. This can be used to control the following functions:

- ▶ Input of letters, numbers and characters by automatic signature recognition
- ▶ Scrolling through album covers
- ▶ Operating the DVD main menu
- ▶ Moving the navigation map



Operating unit with TONE/CAR button

609_098



Operating unit with NAV/TEL button

609_099



Operating unit with MMI touch

609_100

Button combinations for service personnel

System reset

To restart (reset), the following buttons must be briefly pressed simultaneously:

- ▶ Turn-push button
- ▶ Softkey at top right
- ▶ MENU



Shortcut for system reset

609_101

Engineering menu

The Engineering menu is required, for example, to install software updates. To access the menu, the following buttons must be pressed successively and kept pressed down:

- ▶ Top left softkey
- ▶ BACK



Shortcut for Engineering menu

609_102

Screenshot

A screenshot is a copy of the current MMI display screen. To save the screenshot, an SD card is inserted into the SD card reader and the following buttons must be pressed successively and kept pressed down.

- ▶ Bottom left softkey
- ▶ Bottom right softkey

In the case of MIP Standard, the screen briefly goes blank to indicate that saving is in progress. In the case of MIP High, the message "take screenshot" appears at the top left of the MMI display.



Shortcut for screenshot

609_103

System reset with Audi Radio (MIB Entry)

If Audi Radio is fitted, to restart the system the following buttons must be pressed simultaneously and kept pressed down for at least five seconds:

- ▶ ON/OFF switch
- ▶ Forward button



Shortcut for reset

609_104

MMI display

(front information display unit J685)

The MMI display in the Audi A3 '13 has a depth of only 11 millimetres. This is achieved by attaching the actual TFT screen directly to the ultralight magnesium housing. It is seated on the dash panel and is retracted electrically.

There are two versions of the screen with the following features:

- ▶ 5.8" TFT colour monitor with 400 x 240 pixel resolution with MMI Radio
- ▶ 7.0" TFT colour monitor with 800 x 480 pixel resolution with MMI Navigation plus

The kinematic mechanism of the MMI display (display swivel mechanism VX452) has the following electrical components:

- ▶ Electric motor with Hall sensor (display opening/closing motor V301)
- ▶ Two limit switches (display opening limit switch F330 and display closing limit switch F331)

The number of motor revolutions is registered by the Hall sensor while the display is extending and retracting and evaluated by the information electronics control unit 1 J794. The number of motor revolutions dictates the end position of the display. In addition, both display limit switches are evaluated. The display extends and retracts automatically and can if needed be extended and retracted using the display unit button E506.

If the "display opening limit switch" F330 is triggered while the display is extended, e.g. by briefly pushing down on the display from above, the electric motor is activated and the display retracts automatically. This safety function lessens the likelihood of third party damage.



5.8" TFT colour screen with MMI Radio

609_105



7.0" TFT colour screen with MMI Navigation plus

609_106



609_107

MMI display

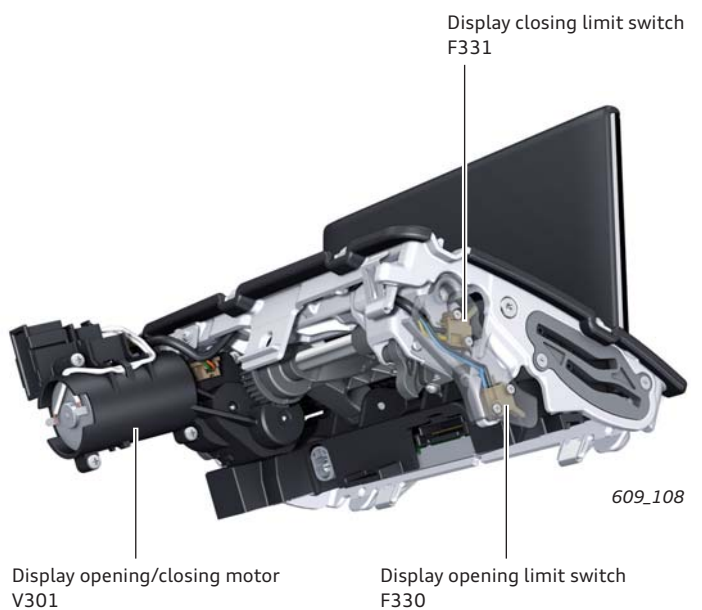

609_108

MMI display and kinematic mechanism

Aerials overview

The aerials in the Audi A3 '13 are distributed across the rear window and the roof aerial R216. The boosters for the aerials in the rear window and in the rear spoiler are mounted to the rear hatch.

The in-car booster connections are adapted to trim level. Only the connections which are actually needed are installed.

Roof aerial R216 (Europe/rest of world)

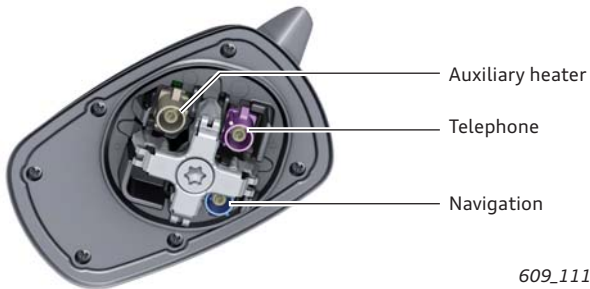

Roof aerial R216 (North America)

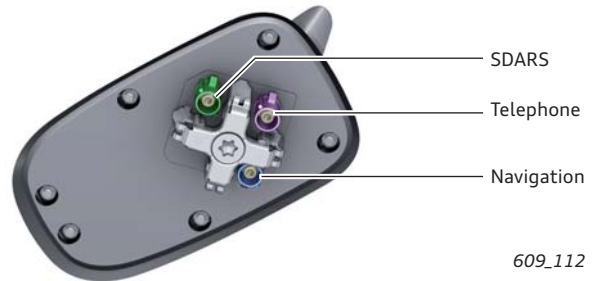

Overview of rear window aerials with boosters

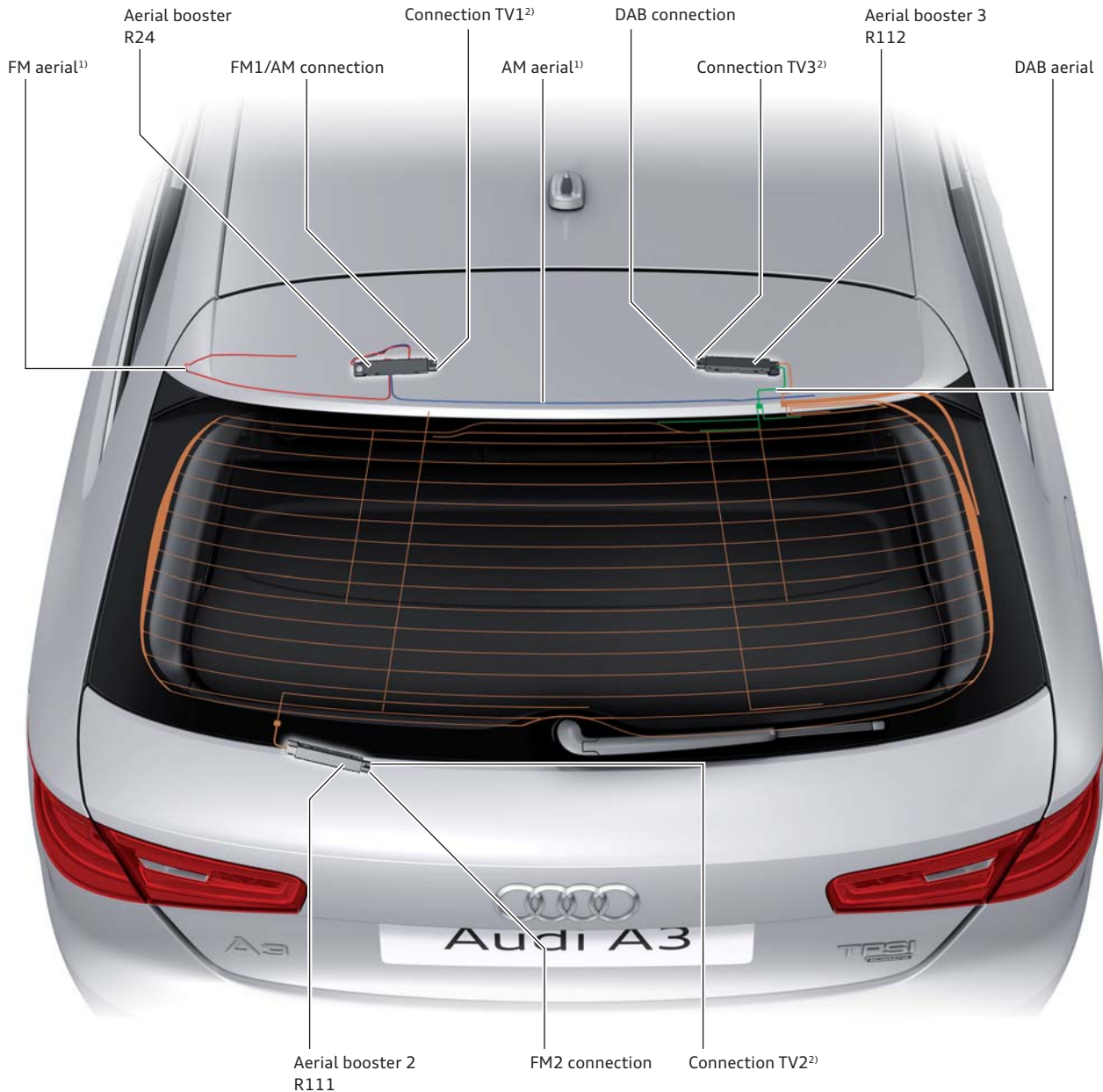

¹⁾ integrated in rear spoiler

²⁾ TV is available Japan spec model only

Sound systems

The Audi A3 '13 is fitted as standard with four loudspeakers in the front with a max. power output of 20 watts per side. The Basic Plus sound system with eight loudspeakers is fitted in combination with MMI Radio and higher. The audio amplifier is integrated in the information electronics control unit 1 J794.

The optional Audi sound system also comes with a centre speaker on the dash panel and a subwoofer in the spare wheel well. The audio amplifier integrated in the information electronics control unit 1 J794 has a total power output of 180 watts.

Audi A3 '13 with Audi sound system



609_109

Audi A3 '13 with Bang & Olufsen Sound System

The optional Bang & Olufsen Sound System delivers a total power output of around 705 watts. With its 5.1 Surround Sound speakers, it provides excellent sound quality. The external Bang & Olufsen audio amplifier (digital sound package control unit J525) powers a total of 13 loudspeakers and the subwoofer through its 15 channels. The subwoofer is driven through two channels.

The external audio amplifier is located below the left front seat and is connected to the information electronics control unit 1 J794 via the MOST bus. In models fitted with the Bang & Olufsen Sound System, both bass loudspeakers in the front doors are highlighted by indirect lighting. The LEDs installed for this purpose are driven by the door control units.

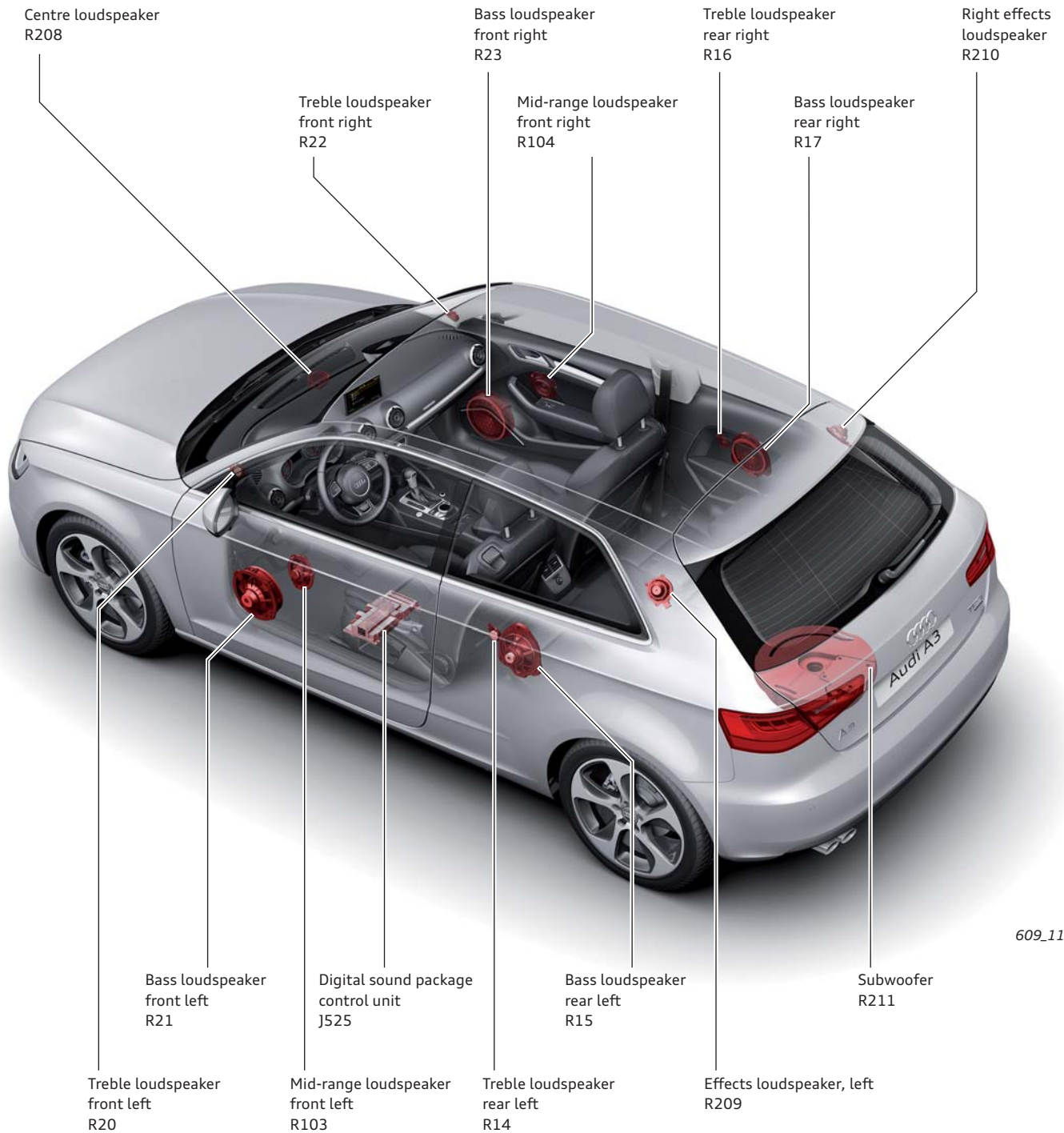

609_110

Universal Mobile Phone Preparation – Audi phone box

In the Audi A3 '13, the so-called infotainment box is located in the centre console. It is equipped as standard with an AUX-In connection.

If the Universal Mobile Phone Preparation (9ZE) is fitted, the vehicle receives the Audi phone box in place of the infotainment box. It accepts any mobile phone. If there is a mobile phone in the phone box, it is connected to the vehicle's aerial by a coupling aerial. The coupling aerial is located directly below the cradle.

The mobile phone can be charged via a USB port in the phone box. For this purpose, an optional telephone-specific cable can be plugged into the USB port in order to charge the telephone. The USB port has a charging function only (USB charging).

An AUX-In socket for 3.5 mm jack plugs is integrated in the cradle as standard. If the Audi A3 '13 is equipped with the optional Audi music interface (AMI) as standard, the AMI connector is fitted in place of the AMI connector's AUX-In socket.



609_114

Audi phone box



609_115

Audi phone box front

Design

The cradle is comprised of up to three parts:

- ▶ the housing
- ▶ the connector block
- ▶ the coupling aerial (telephone bracket R126)

The connector block includes up to two connectors and can only be replaced as a complete unit. There are four different connector combinations to allow for all possible equipment versions.

- ▶ AUX-In
- ▶ USB charging and AUX-In
- ▶ AMI
- ▶ USB charging and AMI

The service designation for the AUX-In and AMI connectors is "external audio sources connection R199". The USB charging port has the service designation "USB port bracket R193".



AUX-In connector block

609_116



USB charging and AUX-In connector block

609_117



AMI connector block

609_118



USB charging and AMI connector block

609_119

Coupling aerial

The coupling aerial (telephone bracket R126) is attached to the base of the cradle. During the development phase, care was taken to ensure that reception is the same at all points in the cradle. To allow reception across the entire base of the cradle, a full-surface coupling aerial was developed. This is why an aerial is attached to the top and bottom of the aerial module. The position of the mobile phone in the cradle therefore has no effect on reception.

The coupling aerial has two connections to the vehicle:

- ▶ Aerial connector to mobile phone booster R86 (compensor)
- ▶ 4-pin connector to information electronics control unit 1 J794



Coupling aerial (telephone bracket R126)

609_120

Adaptor

To offer customers maximum convenience, new adaptors will be available for making USB connections between the vehicle and mobile phones. These adaptors were developed by Audi and come fitted with spiral cable and an angled USB port. The spiral cable not only prevents tangling but also provides ample freedom of movement when plugging and unplugging mobile phones. The adaptors are fully functional USB cables and therefore can also be used for connecting to a computer.

They are currently available in the following versions:

- ▶ Micro-USB port with straight connector
- ▶ Micro-USB port with angled connector
- ▶ Connection with 3.5 mm jack plug
- ▶ Connection for iPhone
- ▶ Connection for Sony Ericsson mobile phones



609_121



Note

For further information on adaptors, refer to the Electronic Parts Catalogue (ETKA).

Service

Special tools and workshop equipment

T10172 with T10172/11

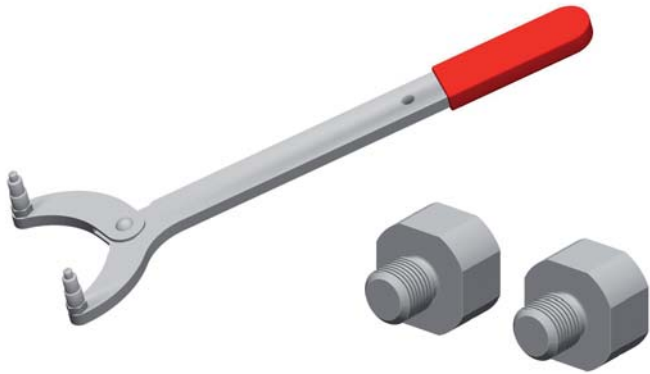

609_159

609_160

Tensioning the timing belt

T10490



609_162

Locking the crankshaft with round and oval belt pulleys

T10492



609_164

Locking the high-pressure pump and camshaft

T10489



609_161

Disconnecting the high-pressure pump drive gear

T10491



609_163

Removing and fitting the oxygen sensor

T10493

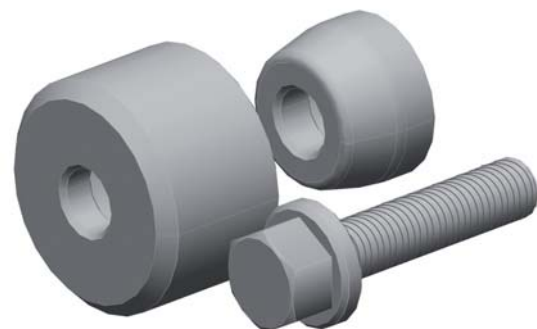

609_165

Fitting the camshaft seal

T10503



609_151

For use with reversible ratchet attachment for bits VAS 6784

T10502



609_152

Fitting the protective cap on the brake caliper housing

VAS 6748



609_178

Removing and fitting the airbag control unit, in combination with T10503

VAS 6338/38



609_179

Flushing the air conditioner refrigerant circuit

Inspection and maintenance

The following service intervals are displayed:

- ▶ Oil change service
- ▶ Mileage-based service events
- ▶ Time-based service events

Example of a service interval display in the MMI

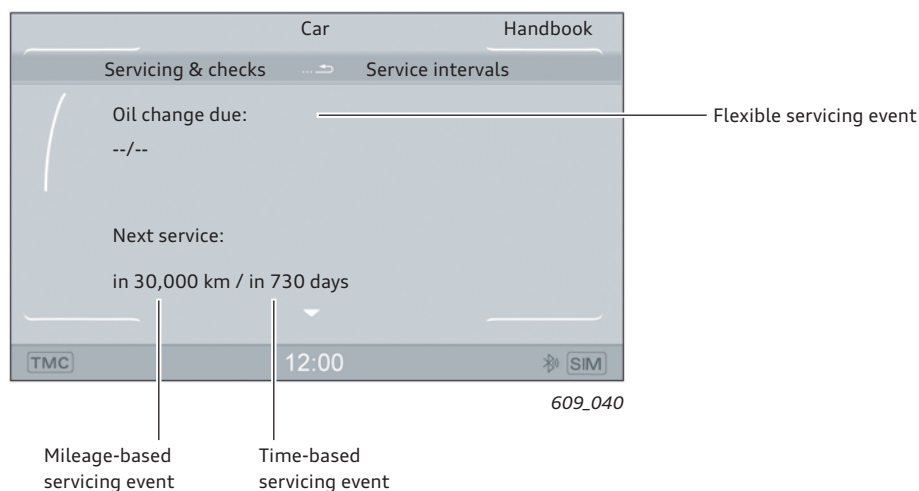

In new vehicles, the next oil change due box (flexible servicing event) is initially blank. A servicing interval computed from the driving profile and engine load is displayed after the vehicle has covered approx. 500 km. The display "Oil change due" then switches to "Next oil change".

The value in the mileage-based servicing events box is now 30,000 km for new vehicles, and is counted down in increments of 100 km. The value in the time-based servicing events box is now 730 days (2 years) for new vehicles and is updated on a daily basis (upwards of a total mileage of approx. 500 km).

Overview of maintenance intervals (Europe)

| | Audi A3 1.6 TDI | Audi A3 2.0 TDI | Audi A3 1.2 TFSI | Audi A3 1.4 TFSI | Audi A3 1.8 TFSI | Audi A3 2.0 TFSI |
|---------------------------------------|--|--------------------------|--------------------------|--------------------------|---------------------------|------------------------|
| Oil change interval | between 15,000 km / 1 year and 30,000 km / 2 years | | | | | |
| Service interval | 30,000 km / 2 years | 30,000 km / 2 years | 30,000 km / 2 years | 30,000 km / 2 years | 30,000 km / 2 years | 30,000 km / 2 years |
| Pollen filter | 30,000 km / 2 years | 30,000 km / 2 years | 30,000 km / 2 years | 30,000 km / 2 years | 30,000 km / 2 years | 30,000 km / 2 years |
| Air filter | 90,000 km / 6 years | 90,000 km / 6 years | 60,000 km / 6 years | 60,000 km / 6 years | 90,000 km / 6 years | 90,000 km / 6 years |
| Spark plugs | — | — | 60,000 km / 6 years | 60,000 km / 6 years | 60,000 km / 6 years | 60,000 km / 6 years |
| Fuel filter | 90,000 km | 90,000 km | — | — | — | — |
| Timing gear | 240,000 km ³⁾ | 240,000 km ³⁾ | 210,000 km ³⁾ | 210,000 km ³⁾ | Chain (lifetime) | Chain (lifetime) |
| Brake fluid | Change after 3, 5, ... years | | | | | |
| Haldex oil change¹⁾ | — | 3 years | — | — | 3 years | 3 years |
| Gear oil change²⁾ | — | 60,000 km | — | — | 60,000 km quattro only | 60,000 km |

¹⁾ quattro

²⁾ S-tronic

³⁾ Timing belt inspection



Note

The specifications in the current service literature always apply.

Self Study Programmes

For further information about the technology in the Audi A3 '13, refer to the following Self Study Programmes.



609_039



609_176



609_180



609_181

SSP 608 Audi 1.6l / 2.0l 4-cylinder TDI engines, order number: A12.5S00.92.20

SSP 610 Audi A3 '13 Onboard Power Supply and Networking, order number: A12.5S00.94.20

SSP 611 Audi A3 '13 Vehicle Electronics and Driver Assistance Systems, order number: A12.5S00.95.20

SSP 612 Audi A3 '13 Suspension, order number: A12.5S00.96.20

All rights reserved.
Technical specifications are subject to
change.

Copyright
AUDI AG
I/VK-35
service.training@audi.de

AUDI AG
D-85045 Ingolstadt
Technical status 04/12

Printed in Germany
A12.5S00.93.20