

Audi New Technology 2009 – 2010

Self-Study Program 990193

Audi of America, LLC
Service Training
Printed in U.S.A.
Printed 11/2009
Course Number 990193

©2009 Audi of America, LLC

All rights reserved. Information contained in this manual is based on the latest information available at the time of printing and is subject to the copyright and other intellectual property rights of Audi of America, LLC., its affiliated companies and its licensors. All rights are reserved to make changes at any time without notice. No part of this document may be reproduced, stored in a retrieval system, or transmitted in any form or by any means, electronic, mechanical, photocopying, recording or otherwise, nor may these materials be modified or reposted to other sites without the prior expressed written permission of the publisher.

All requests for permission to copy and redistribute information should be referred to Audi of America, LLC.

Always check Technical Bulletins and the latest electronic repair literature for information that may supersede any information included in this booklet.

Table of Contents

R8 with 5.2L V10 FSI Engine	1
Packaged Ultrasonic Level Sensor (PULS)	17
OB5 S Tronic Transmission.	20
Sport Differential.	44
Indirect Tire Pressure Monitoring.	69
MMI 3G	73
Knowledge Assessment	93

The Self-Study Program provides introductory information regarding the design and function of new models, automotive components or technologies.

The Self-Study Program is not a Repair Manual!
All values given are intended as a guideline only.
Refer to the software version valid at the time of publication of the SSP.

For maintenance and repair work, always refer to the current technical literature.

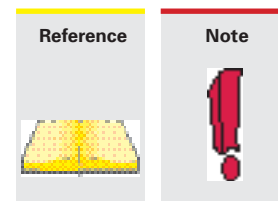

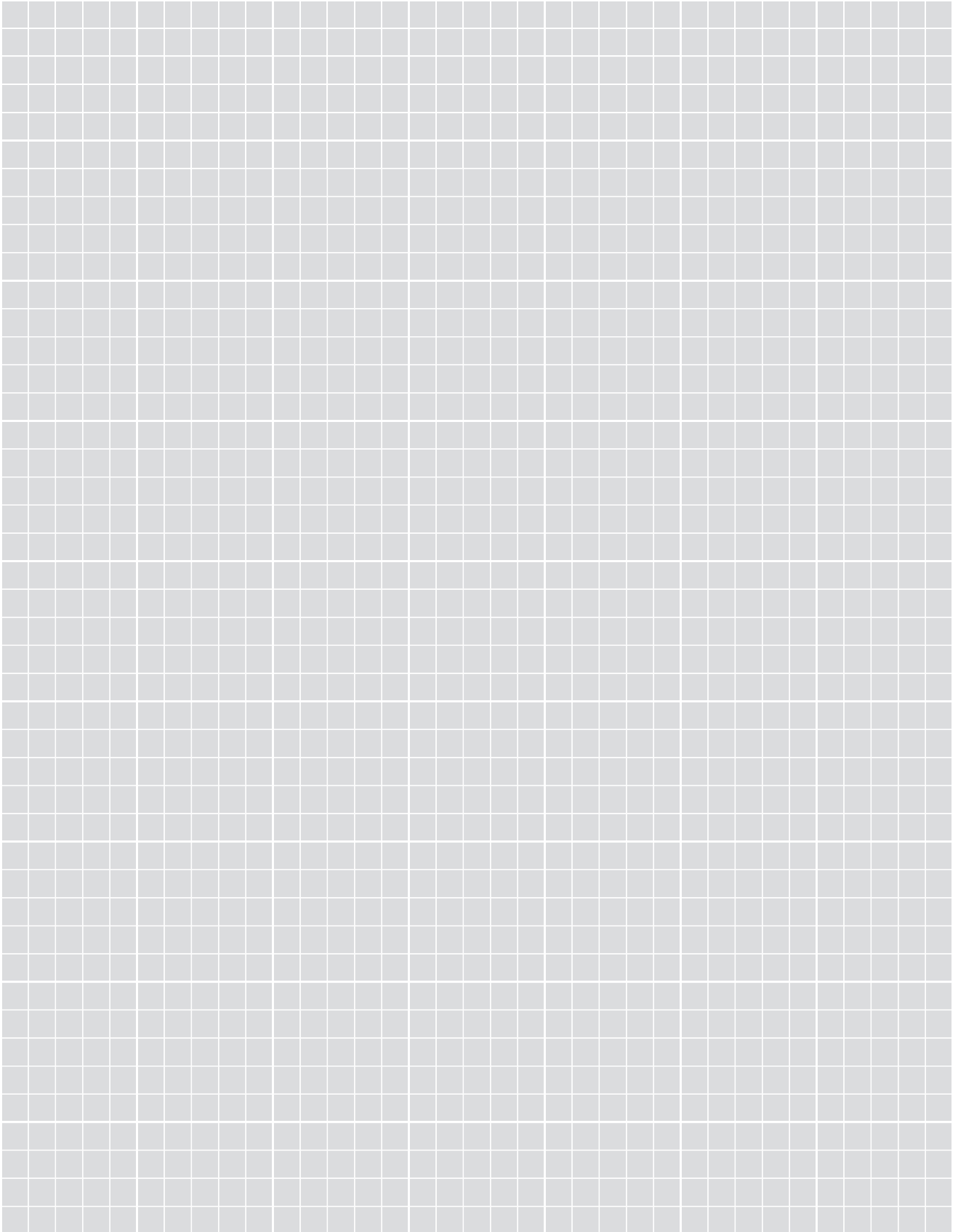

R8 with 5.2L V10 FSI Engine

Audi continues to build on its leadership position in the high-performance sports car segment with the R8 5.2L V10 FSI quattro. The top-of-the-line model of the R8 model series was developed jointly with quattro GmbH. Its ten-cylinder engine develops 525 hp (386 kW) which is capable of delivering breathtaking performance.

Audi technologies such as quattro permanent all wheel drive, lightweight aluminum body (ASF) and innovative all-LED lights propel the R8 5.2L V10 to the top of its competitive field.

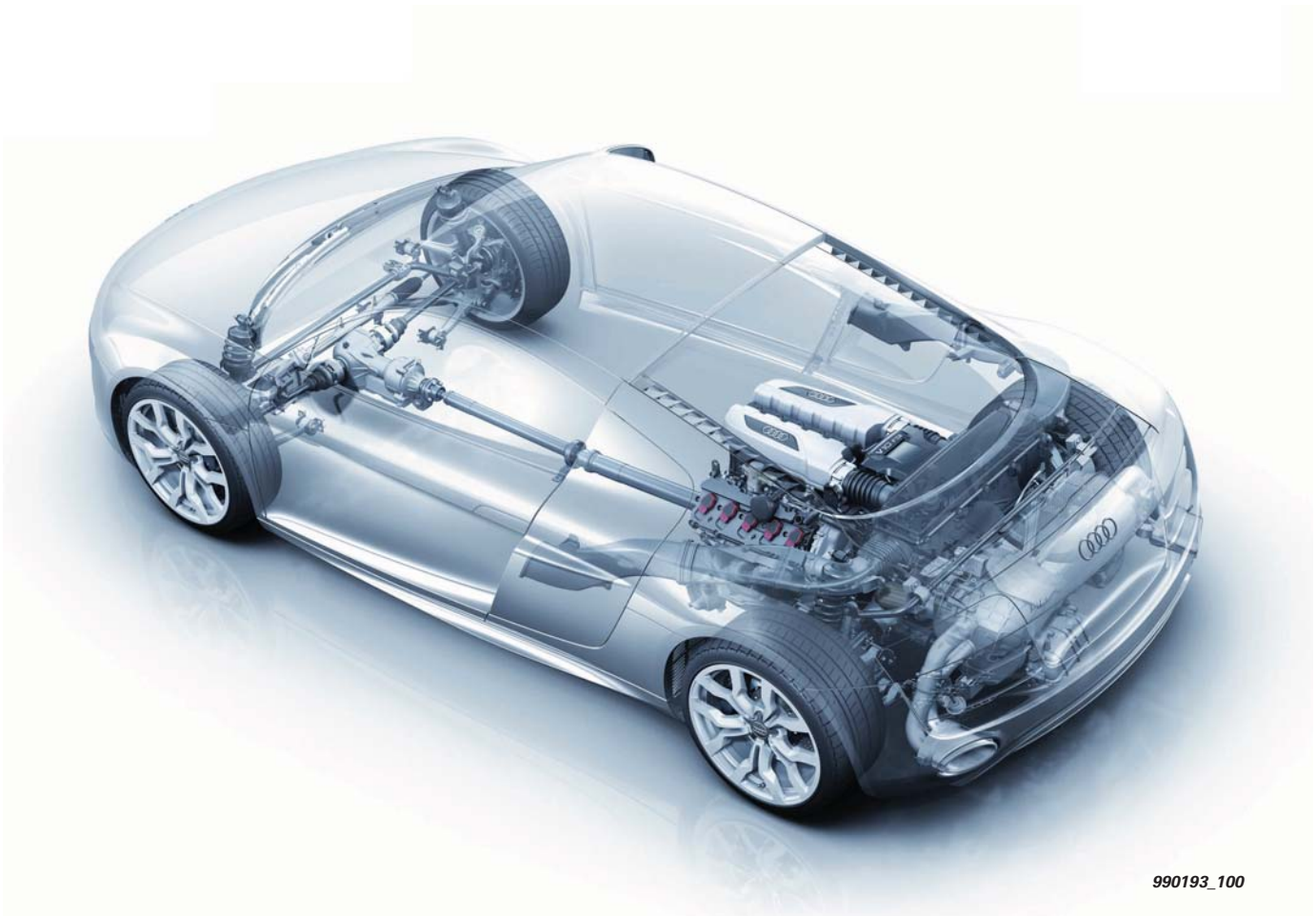

990193_100

At a glance:

Engine

- Newly developed V10 with 5.2 liters displacement, FSI direct injection and dry sump lubrication
- Superior performance 525 hp (386 kW) and 390 lb ft (530 Nm) of torque

Power train

- Six-speed manual transmission; optional sequential R tronic with paddle shifters on steering wheel and "Launch Control" function
- quattro permanent all wheel drive with rear-wheel bias

Chassis

- Dual aluminum wishbone suspension
- High-performance brakes, optional with ceramic discs
- 19-inch wheels
- Audi magnetic ride adaptive suspension

Body and design

- Lightweight, extremely rigid aluminum ASF body weighs only 436 lb (210 Kg)
- Spacious interior and high level of everyday utility
- Exterior and interior design with distinctive new elements
- All-LED lights as standard

R8 with 5.2L V10 FSI Engine

Technical Specifications

Engine:

Type	Naturally aspirated 5.2 liter V10 spark ignition engine with FSI, 90° cylinder angle, 4-valve per cylinder, double overhead camshafts (DOHC), intake manifold with charge movement flaps
rpm	8700 rpm
Arrangement	Mid-mounted, longitudinal
Bore	3.33 in (84.5 mm)
Stroke	3.65 in (92.8 mm)
Displacement	317.6 cu in (5,204 ccm)
Compression ratio	12.5 : 1
Fuel requirement	Premium unleaded
Horsepower	525 hp (386 kW) @ 8000 rpm
Torque	391 lb ft (530 Nm) @ 6500 rpm

Engine design:

Cylinder block	Aluminum alloy incorporating silicon crystals
Connecting rods	Forged steel / large ends cracked
Pistons	Aluminum
Crankcase	High strength aluminum alloy casting
Crankshaft	Forged steel, 5 main bearings
Cylinder head	Aluminum alloy casting
Valve train	Chain-driven DOHC, continuous intake and exhaust camshaft adjustment
Firing order	1-6-5-10-2-7-3-8-4-9
Cooling system	Water-cooled, thermostatically controlled radiator fan
Lubrication system	Dry sump oil system
Fuel injection	FSI
Emission system	Two metal primary catalytic converters, two metal main catalytic converters, four heated oxygen sensors, secondary air injection system
Fuel	Super Plus ROZ 98 (Premium unleaded — 9 AKI)

Electrical system:

Battery	110 amp/hour
Alternator	14.0 volts 190 amp

Drive train:

Transmission	6-speed manual with launch control / optional R tronic with launch control	
Type	<u>Manual</u>	<u>R tronic</u>
Gear ratios:	1st	4.373
	2nd	2.709
	3rd	1.925
	4th	1.502
	5th	1.239
	6th	1.035
	Reverse	3.713
	Final drive	3.077
Center differential	Viscous clutch	

Steering:

Type	Hydraulically assisted rack-and-pinion
Ratio	17.3
Turning circle (curb to curb)	38.7 ft (11.8 m)

R8 with 5.2L V10 FSI Engine

Suspension:		
Front	Double aluminum wishbone	
Rear	Double aluminum wishbone	
Brakes:		
Service brake: Discs/calipers	Disc brakes, internally vented / eight piston calipers at front, 4 piston calipers at rear	
Front	14.4 in (365 mm)	
Rear	14.4 in (365 mm)	
Parking brake	Mechanically actuated at the rear wheels	
Wheels (standard only):		
Size	Front: 8.5J x 19, Rear: 11J x 19 Alloy	
Tire (standard only):		
Size	Front: 235/35 91Y, Rear: 295/30 100Y	
Body:		
Material	Multi-step anti-corrosion protection	
Corrosion protection	Audi Space Frame (ASF)	
Capacity:		
Engine oil	12.7 qt (12.0L)	
Fuel tank	23.8 gal (90L)	
Reserve	2.6 gal (10L)	
Cooling system	5.3 gal (24.0l)	
Exterior dimensions:	<i>[see next page]</i>	
Interior dimensions:		
Seating capacity	2	
EPA class	n/a	
Head room	n/a	
Shoulder room	n/a	
Leg room	n/a	
Interior volume (EPA)	n/a	
Luggage capacity trunk / behind seats	3.5 cu ft (100L) / 3.18 cu ft (90L)	
Performance:		
	5.2 FSI quattro - manual	5.2 FSI quattro - R tronic
0 - 60 mph	3.7 seconds	3.7 seconds
0 - 100 km/h	3.9 seconds	3.9 seconds
0 - 200 km/h	12.0 seconds	12.0 seconds
Top speed	196 mph (316 km/h)	196 mph (316 km/h)
Lateral acceleration	1.2 g	
Fuel economy (EPA estimate):		
	Manual	R-tronic
City	12.0 mpg	13.0 mpg
Highway	20.0 mpg	20.0 mpg
Combined	15.0 mpg	15.0 mpg

R8 with 5.2L V10 FSI Engine

Dimensions

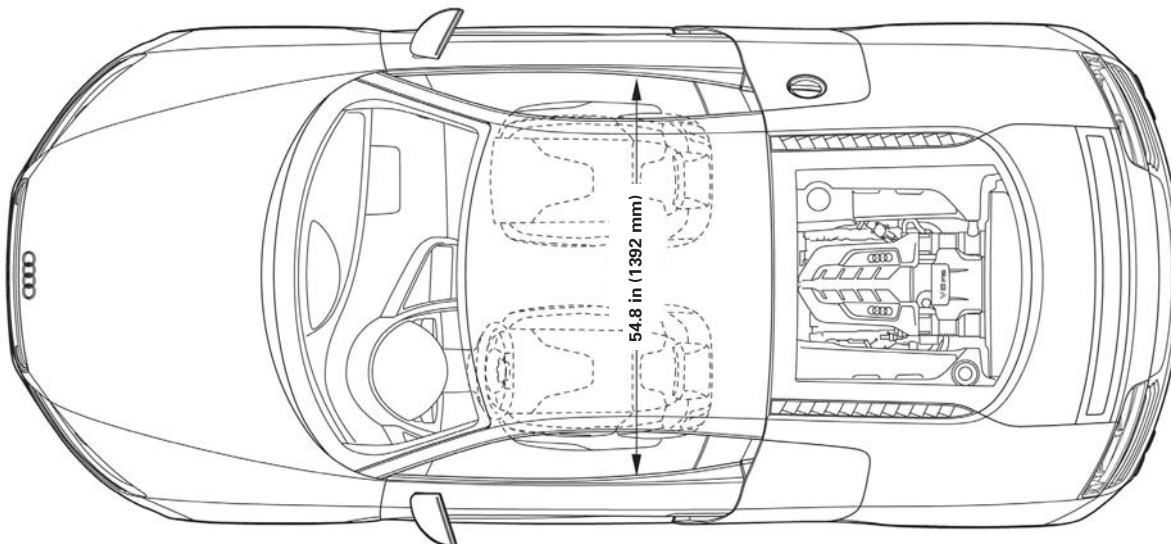
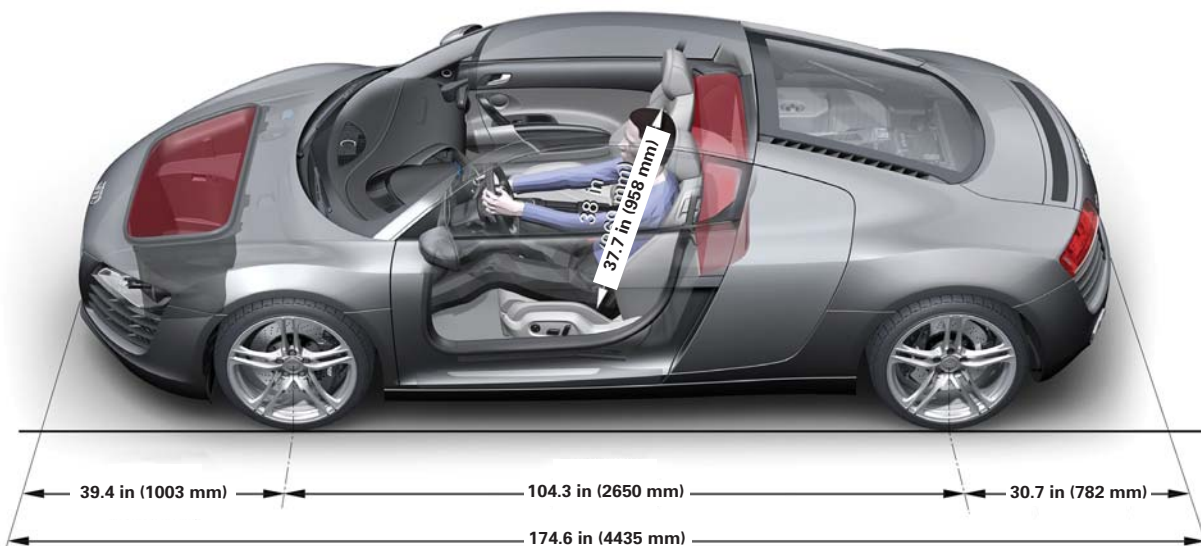
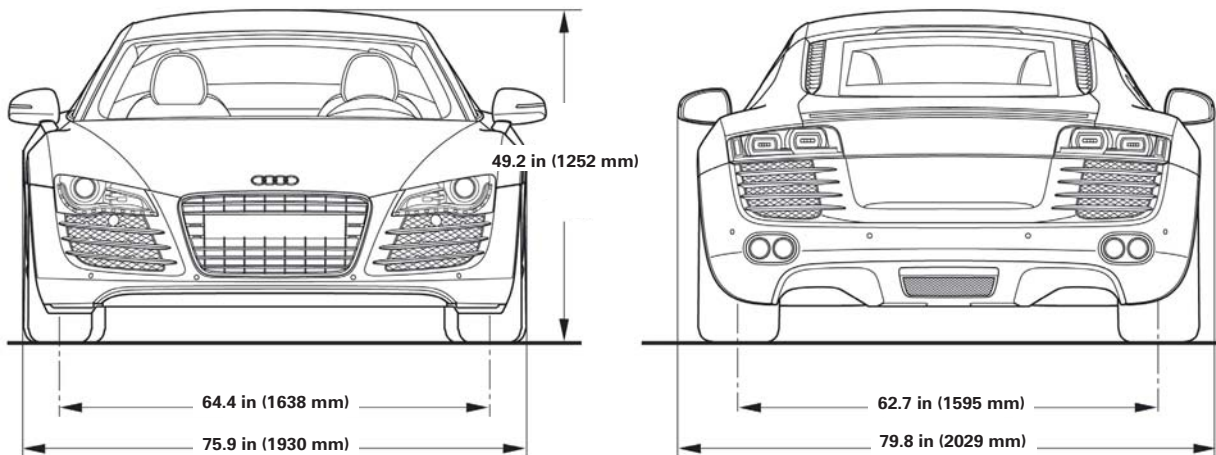

R8 with 5.2L V10 FSI Engine

Like the R8 4.2L, the R8 5.2L V10, uses an Audi Space Frame of aluminum and ultra-light magnesium. It is produced largely by hand in the Neckarsulm manufacturing plant of quattro GmbH.

Maximum precision and the use of the most advanced joining techniques are employed. This includes: 325 ft (99 meters) of welding seams, 782 rivets, and 308 self-tapping screws that hold the body together.

A fully automatic measuring system checks the dimensions of every body with precision in the one-tenth of a millimeter range.



990193_102

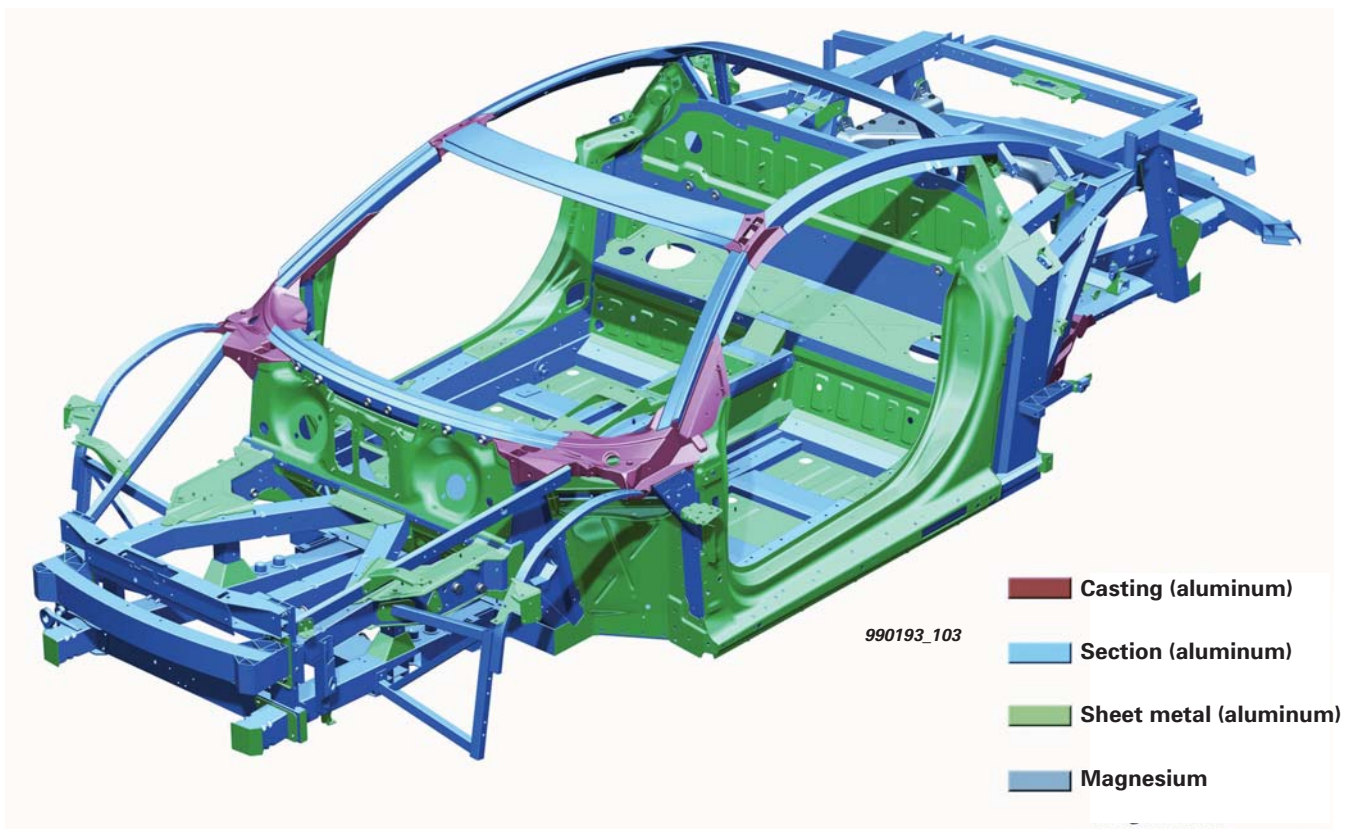

R8 with 5.2L V10 FSI Engine

5.2L V10 FSI Engine

The V10 for the R8 has a total displacement of 5,204 cc and is designed for high-performance.

Specific power output for the R8 V10 is 100.9 hp per liter of displacement. Each horsepower of the engine only needs to move 6.81 lb (3.09 kilograms) of weight. When equipped with a manual transmission, the vehicle only weighs 3571 lb (1,620 kilograms).

The 10-cylinder layout is an ideal design solution for maximum performance. Compared to a V8 with the same displacement, a V10 has smaller and lighter pistons and connecting rods, which makes it a free-revving engine. Compared to a V12, it has fewer components, resulting in lower moving masses and less internal friction. Even with all attached components, the 10-cylinder engine is only 25 inches (646 mm) long, 29 inches (737 mm) wide, and 27 inches (696 mm) high.

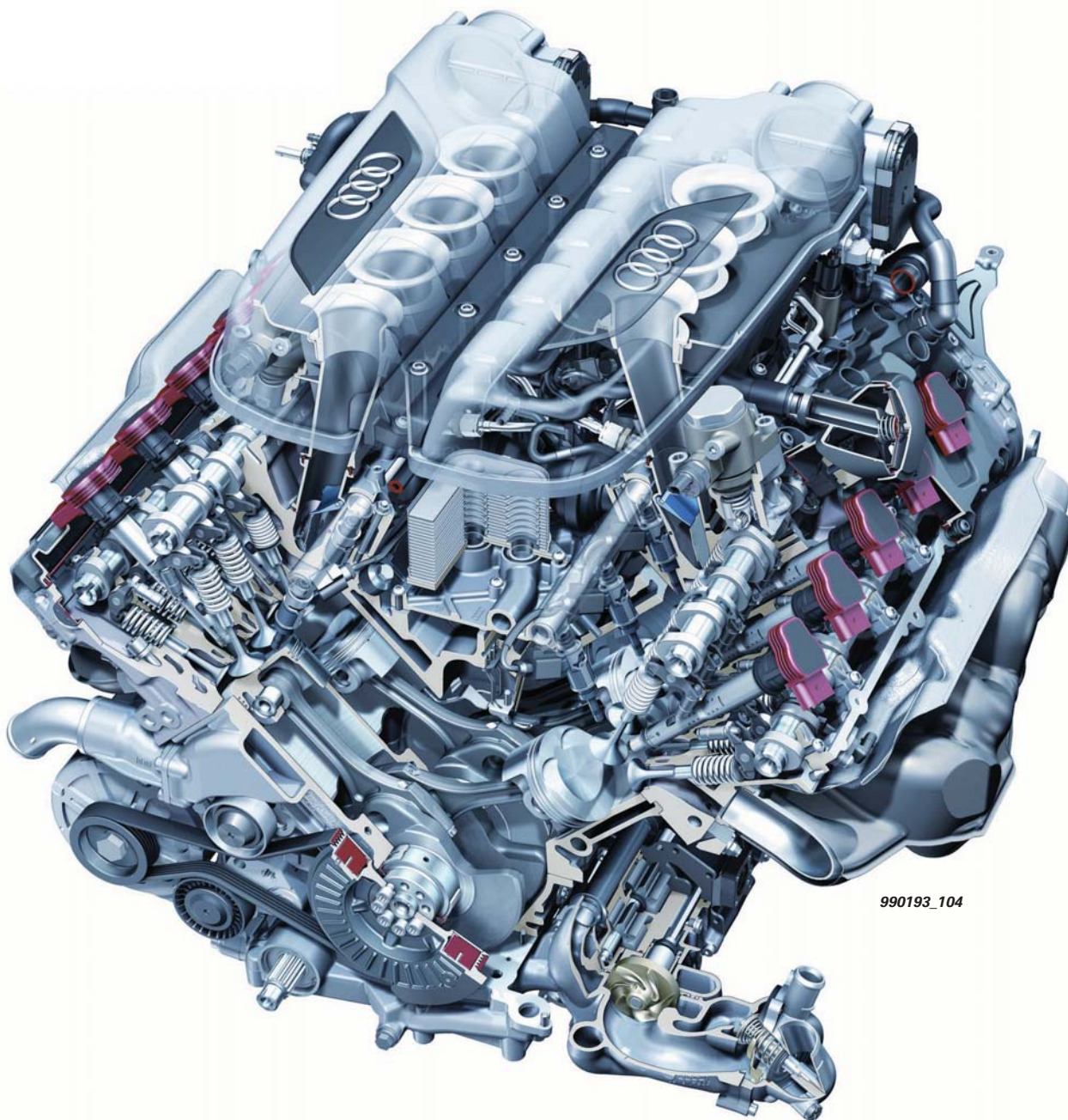

990193_104

R8 with 5.2L V10 FSI Engine

Specifications

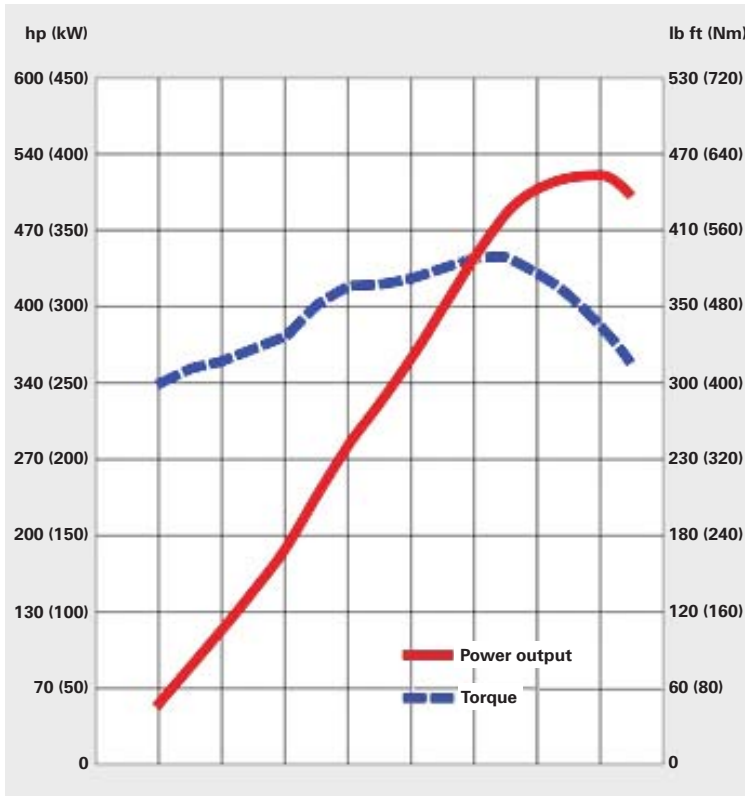

990193_110



990193_113

Displacement:	317.8 cubic inches (5204 cc)
Horsepower:	525 hp SAE (386 kW) @ 8000 rpm
Maximum torque:	391 lb ft (530 Nm) @ 6500 rpm
Maximum rpm:	8700
Fuel requirement:	Premium unleaded

Type:	5.2 liter V10 spark-ignition with FSI, 90° cylinder angle, 4 valve technology, DOHC, intake manifold with charge movement flaps, naturally aspirated
Arrangement:	Longitudinal, mid-engine installation
Bore:	3.33 inches (84.5 mm)
Stroke:	3.65 inches (9.28 mm)
Compression ratio:	12.5:1
Cylinder block:	Aluminum alloy
Connecting rods:	Forged steel
Pistons:	Aluminum
Crankcase:	High strength aluminum alloy casting
Cylinder head:	Aluminum alloy
Valve train:	DOHC chain driven, continuously variable intake and exhaust camshaft adjustment
Firing order:	1-6-5-10-2-7-3-8-4-9
Cooling system:	Water cooled, thermostatically controlled radiator fans
Lubrication system:	Dry sump oil system
Fuel injection/ignition system:	FSI direct injection
Emission system:	Two metal primary converters, two main converters, four heated O ₂ sensors, secondary air system
Fuel:	Super Plus ROZ 98 / Premium unleaded (91 AKI)

R8 with 5.2L V10 FSI Engine

The crankcase is produced by a low-pressure die-casting method. It is made from hypereutectic aluminum-silicon alloy — a high-tech material that combines low weight with high strength. The high silicon content of this alloy gives the cylinder walls the necessary wear resistance to withstand very high average piston velocity.

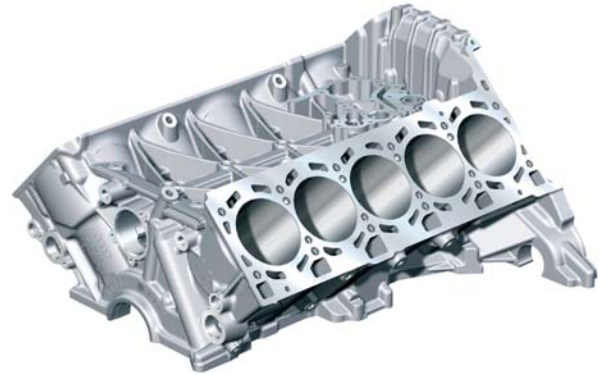

The bedplate design — the lower bearing brackets for the crankshaft are integrated into a single frame — provides the crankcase with maximum rigidity and optimal vibration behavior. Integrally cast iron bearing brackets reduce thermal expansion of the aluminum housing and minimize play in the main crankshaft bearings. The forged crankshaft and forged-steel con rods combine high strength with low weight. The pistons are forged of a high-strength aluminum alloy.



With the dry-sump lubrication system there is no oil pan. The engine has an intake module connected directly to the external oil pump via intake ports.

This intake module does not have a large oil reservoir. Instead it serves as a baffle plate and collects the out-flowing oil generated by the rotation of the crankshaft.

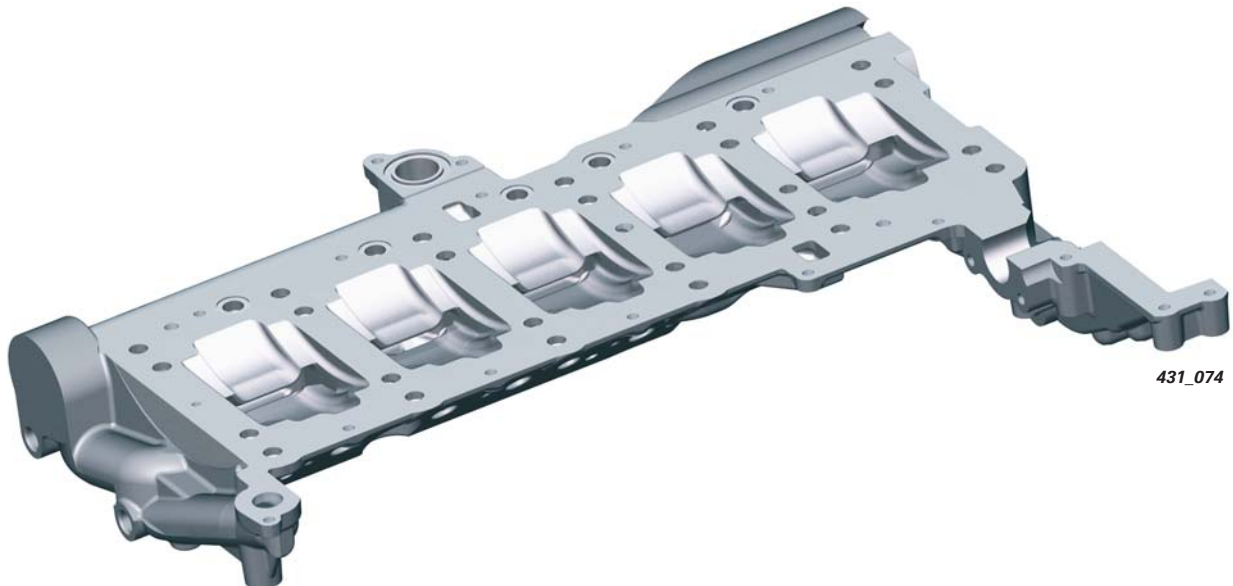

R8 with 5.2L V10 FSI Engine

The crankshaft has been designed as a common-pin type crank pin, and not a split-pin type as on the 5.2L V10 engine used in the Audi S6.

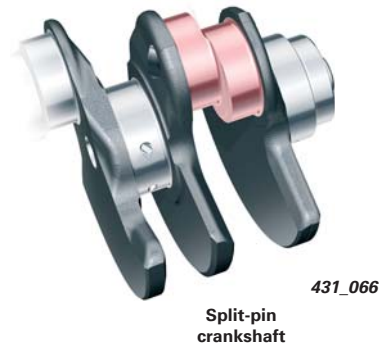
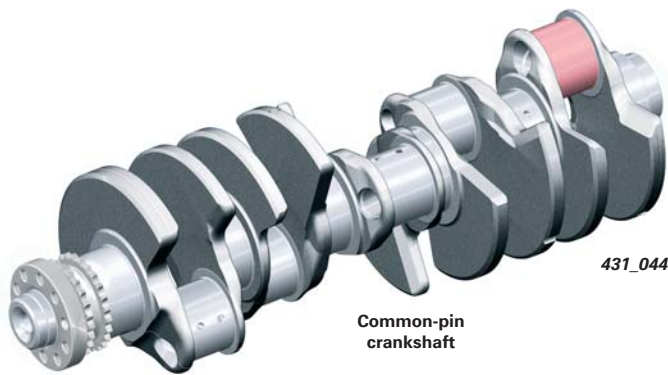

The camshafts, as well as the oil pump, the water pump, and parts of the accessory sub-systems, are driven by maintenance-free chains located on the rear wall of the engine. All four camshafts are adjustable through a 42° crank angle, which provides a wide range of control timing. The valves are actuated by roller-mounted cam followers. The exhaust valves are subject to a high thermal load and are lined with sodium to assist in cooling.

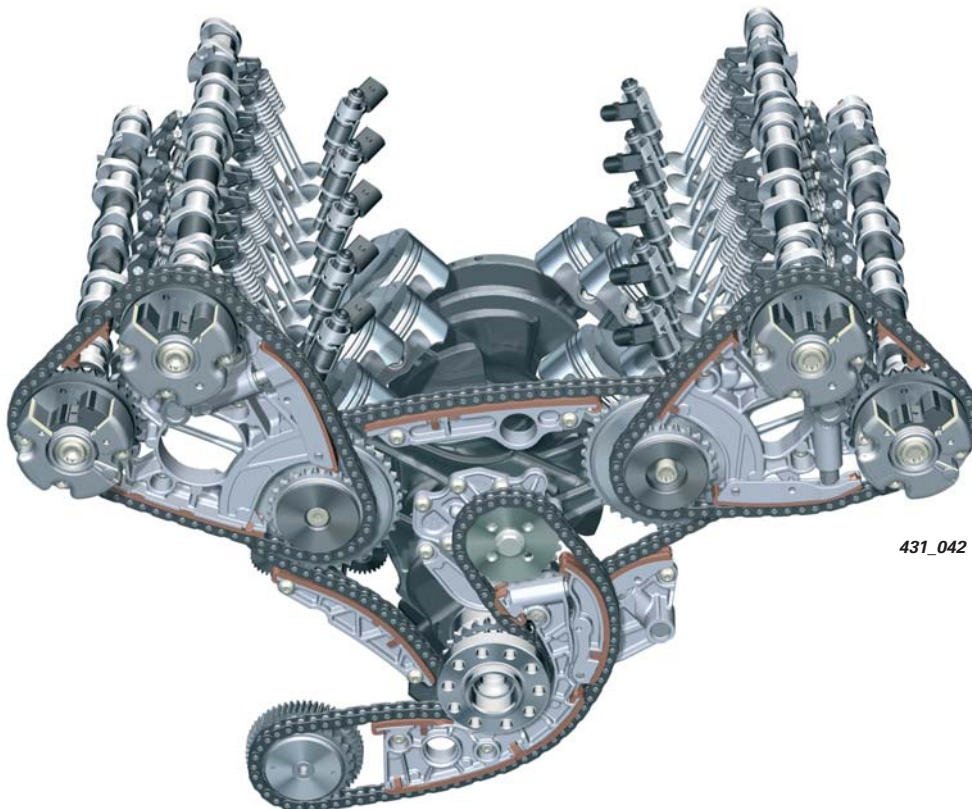

R8 with 5.2L V10 FSI Engine

Dry Sump Lubrication System

The oil pump module is external to the engine and is chain-driven. The pump consists of a suction and feed pump for filling the oil reservoir, and a suction and pressure pump for supplying oil to the engine.

The oil pump and coolant pump are paired to form a single unit, so they can only be replaced as a unit.

Only the thermostat housing and integrated coolant thermostat can be replaced separately.

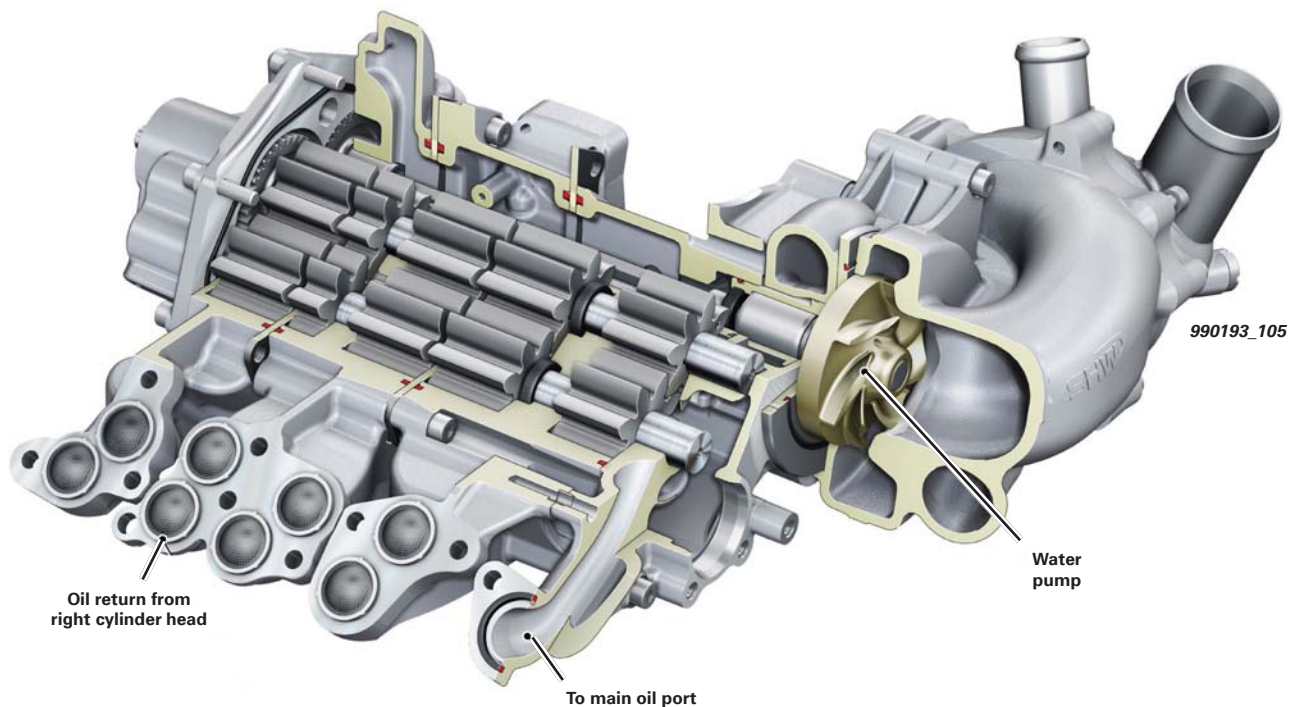

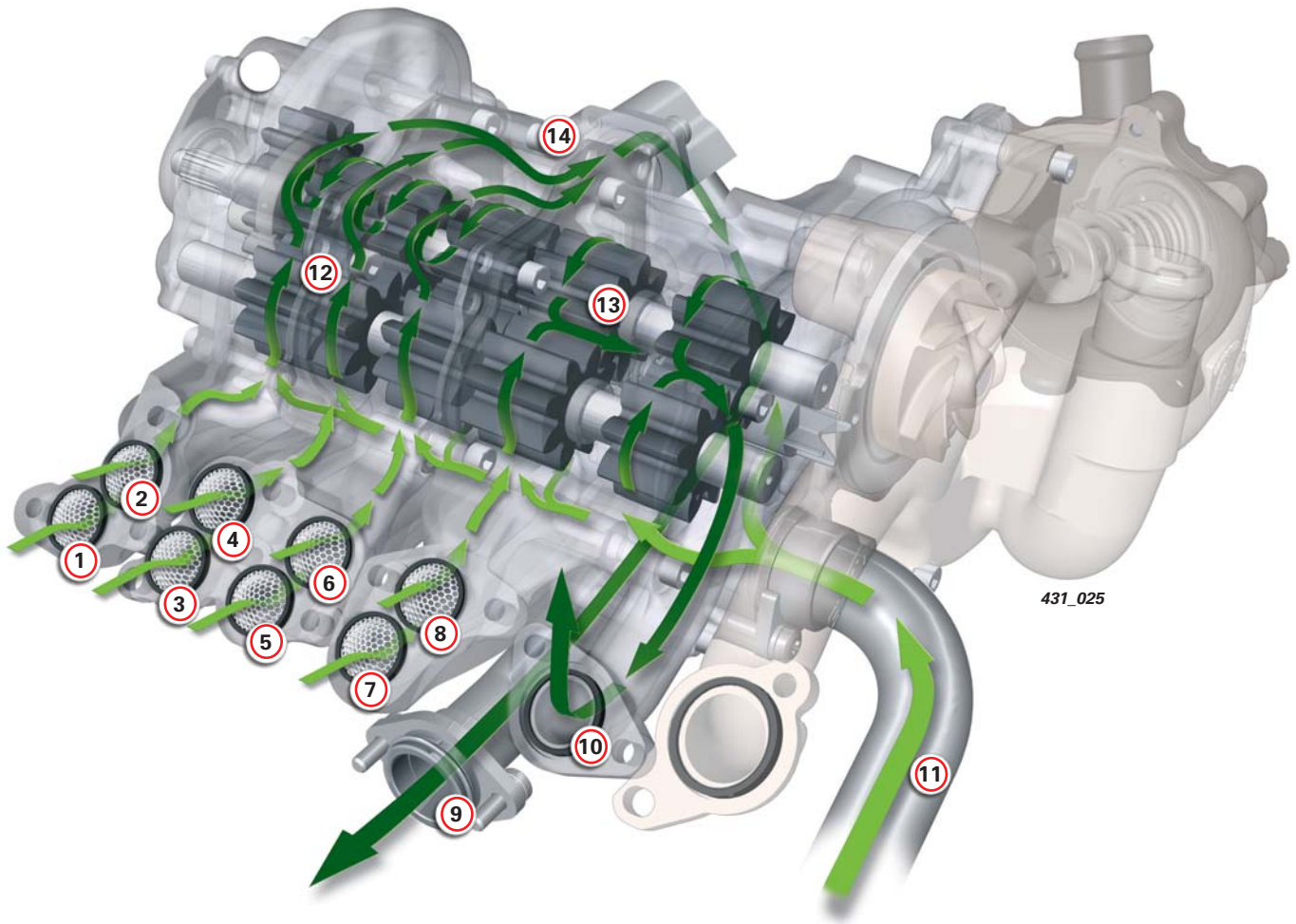

Legend

- | | | | |
|---|-------------------------------------|---|----------------------|
| ① | Crankshaft chamber 5 | ⑧ | Crankshaft chamber 1 |
| ② | Chain case return line | ⑨ | To oil thermostat |
| ③ | Oil return from right cylinder head | ⑩ | To main oil port |
| ④ | Oil return from left cylinder head | ⑪ | From oil reservoir |
| ⑤ | Crankshaft chamber 4 | ⑫ | Suction pump |
| ⑥ | Crankshaft chamber 3 | ⑬ | Pressure pump |
| ⑦ | Crankshaft chamber 2 | ⑭ | Crankcase divider |

R8 with 5.2L V10 FSI Engine

In combination with an oil-to-water heat exchanger located in the inner V of the engine, the 5.2L V10 uses a thermostatically controlled airflow-type oil cooler to regulate engine oil temperature. It is mounted behind the left side-blade of the body.

When the engine oil is cold, the re-circulating, extracted oil is pumped into the oil thermostat housing. When the thermostat is in a closed state, it seals off the inlet leading to the oil cooler, while the oil in the thermostat housing is redirected to the oil reservoir.

When the temperature of the oil exceeds 212°F (100°C), the oil thermostat opens the inlet to the oil cooler.

An expanding element in the thermostat exerts pressure against the thermostat housing. Due to the pressure of the expanding element, the thermostat is displaced against the force of a spring, opening the channel, and simultaneously closing off the inlet leading directly to the oil reservoir.

Oil flows through this port and into the oil cooler, returning from there to the oil thermostat housing before entering the oil reservoir.

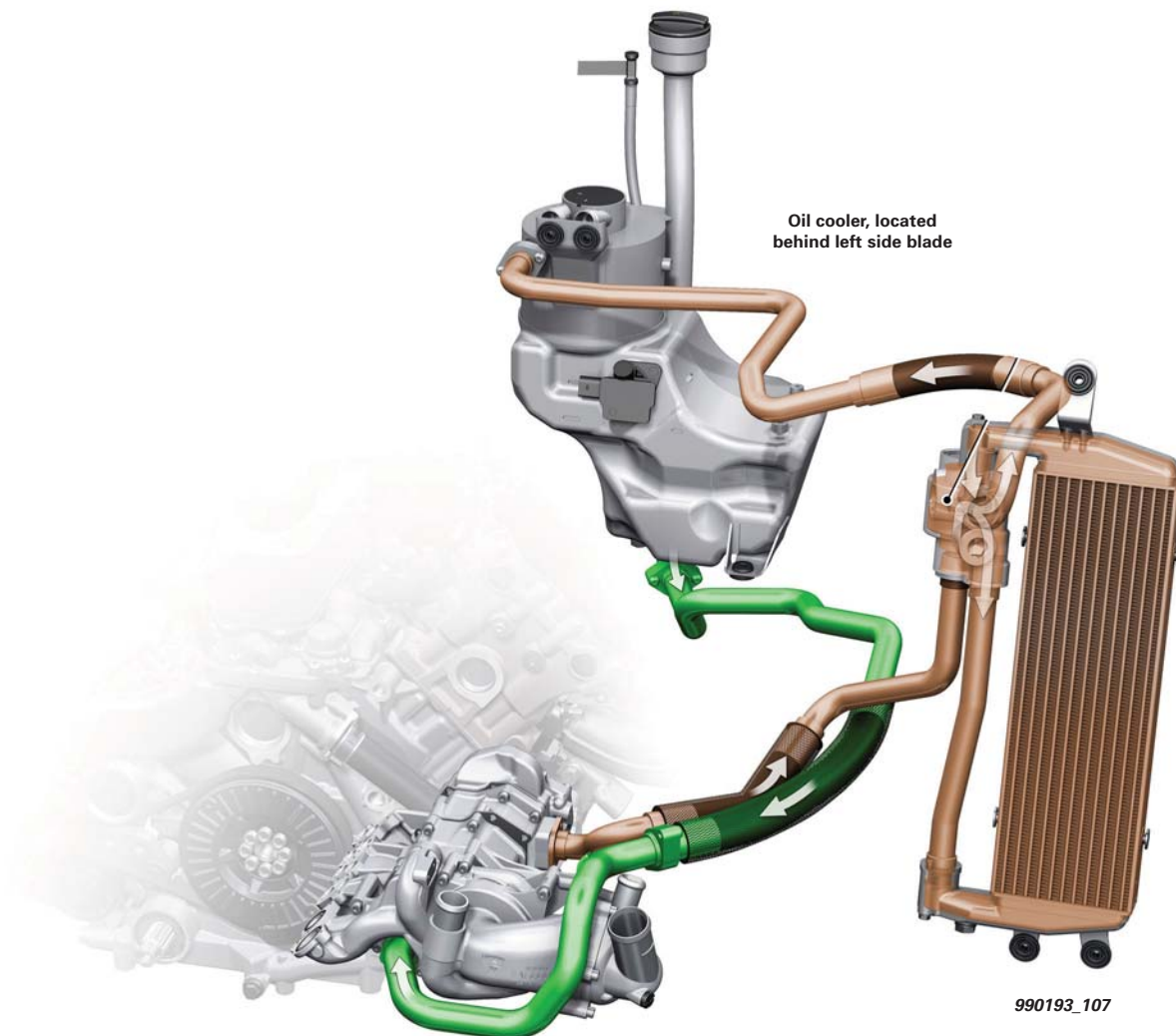

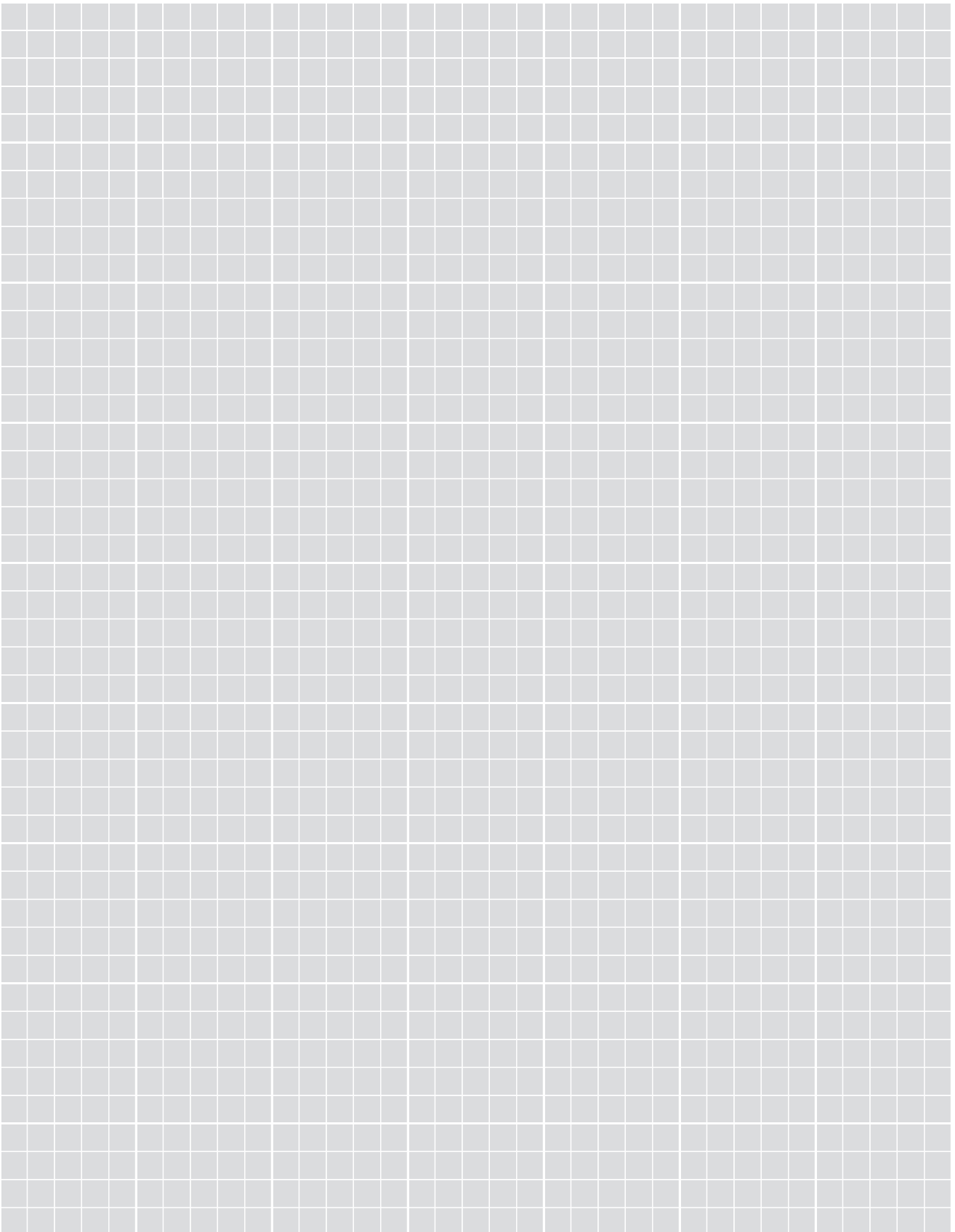

R8 with 5.2L V10 FSI Engine

Mass Air Flow Sensor G70
Intake Air Temperature Sensor G42

Throttle Position Sensor G79
Accelerator Pedal Position Sensor -2- G185

Engine Speed Sensor G28

Knock Sensors -1- and -2- G61, G62

Fuel Pressure Sensor G247

Camshaft Position Sensor G40
Camshaft Position Sensor -3- G300

Throttle Valve Control Module J338
Throttle Drive Angle Sensors -1- and -2- G187, G188
Throttle Drive G186

Engine Coolant Temperature Sensor G62

Low Fuel Pressure Sensor G410

Intake Manifold Runner Position Sensor G336

Heated Oxygen Sensor G39
Oxygen Sensor Behind 3-Way Catalytic Converter
G130 Heated Oxygen Sensor -2- G108
Oxygen Sensor -2- Behind 3-Way Catalytic Converter G131

Brake Booster Pressure Sensor G294

Brake Light Switch F
Brake Pedal Switch F47

Additional Signals:
Oil Temperature Sensor -2- G664 Secondary Injection
Sensor -1- G609
Clutch Position Sensor G476
Cruise Control ON/OFF
Park/Neutral Signal
Terminal 50
Wake Up Signal from Driver's Door Switch via J393

Mass Air Flow Sensor G246
Intake Air Temperature Sensor -2- G299

Camshaft Position Sensor -2- G163
Camshaft Position Sensor -4- G301

Throttle Valve Control Module -2- J544
Throttle Drive Angle Sensors -1- and -2- G297, G298

Knock Sensors -3- and -4- G198, G199

Heated Oxygen Sensor -3- G285
Oxygen Sensor -3- Behind 3-Way Catalytic Converter G287
Heated Oxygen Sensor -4- G286
Oxygen Sensor -4- Behind 3-Way Catalytic Converter G288

Intake Manifold Runner Position Sensor -2- G512

Secondary Air Injection Sensor -2- G610
Fuel Pressure Sensor -2- G624

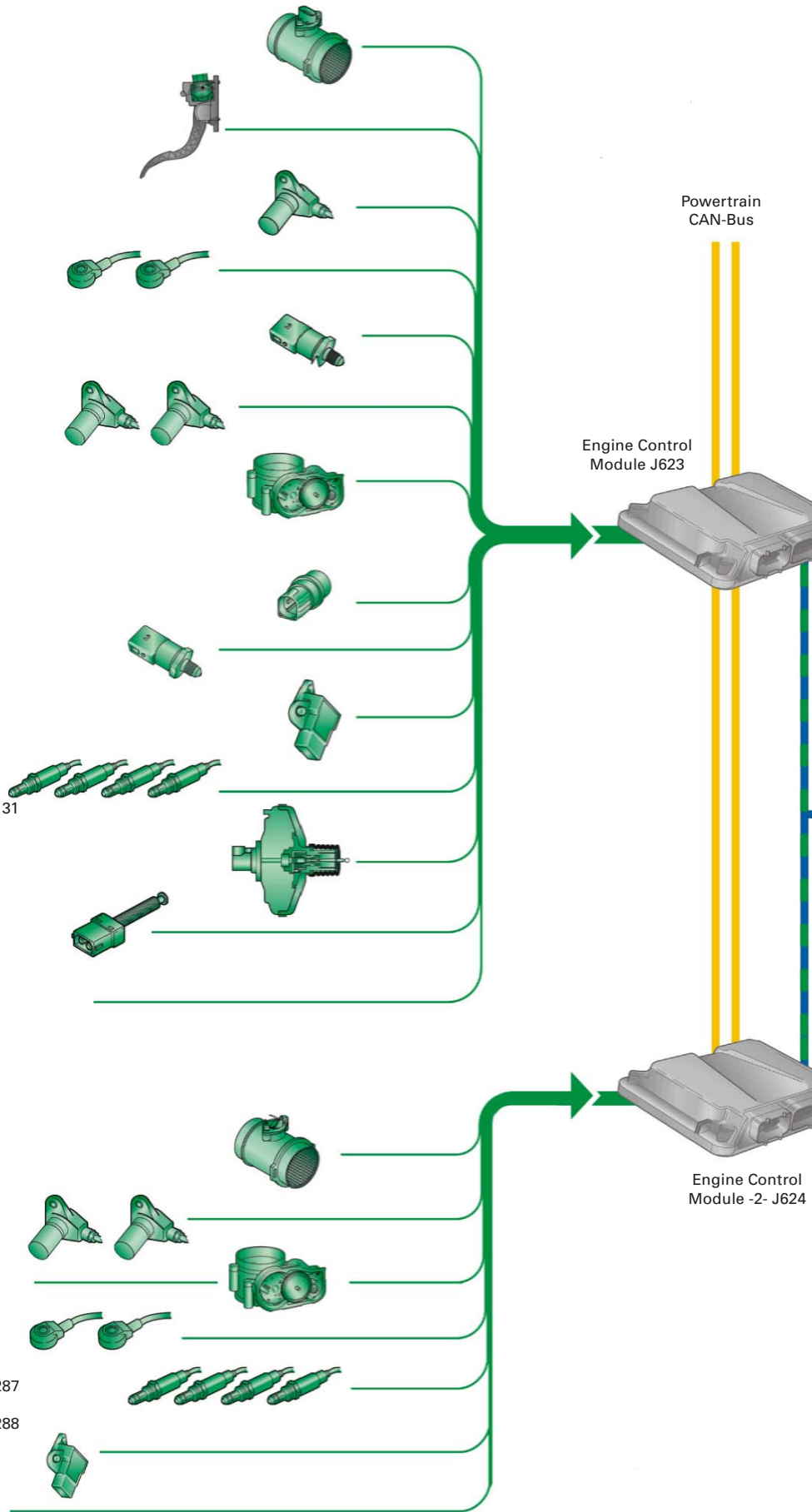

R8 with 5.2L V10 FSI Engine

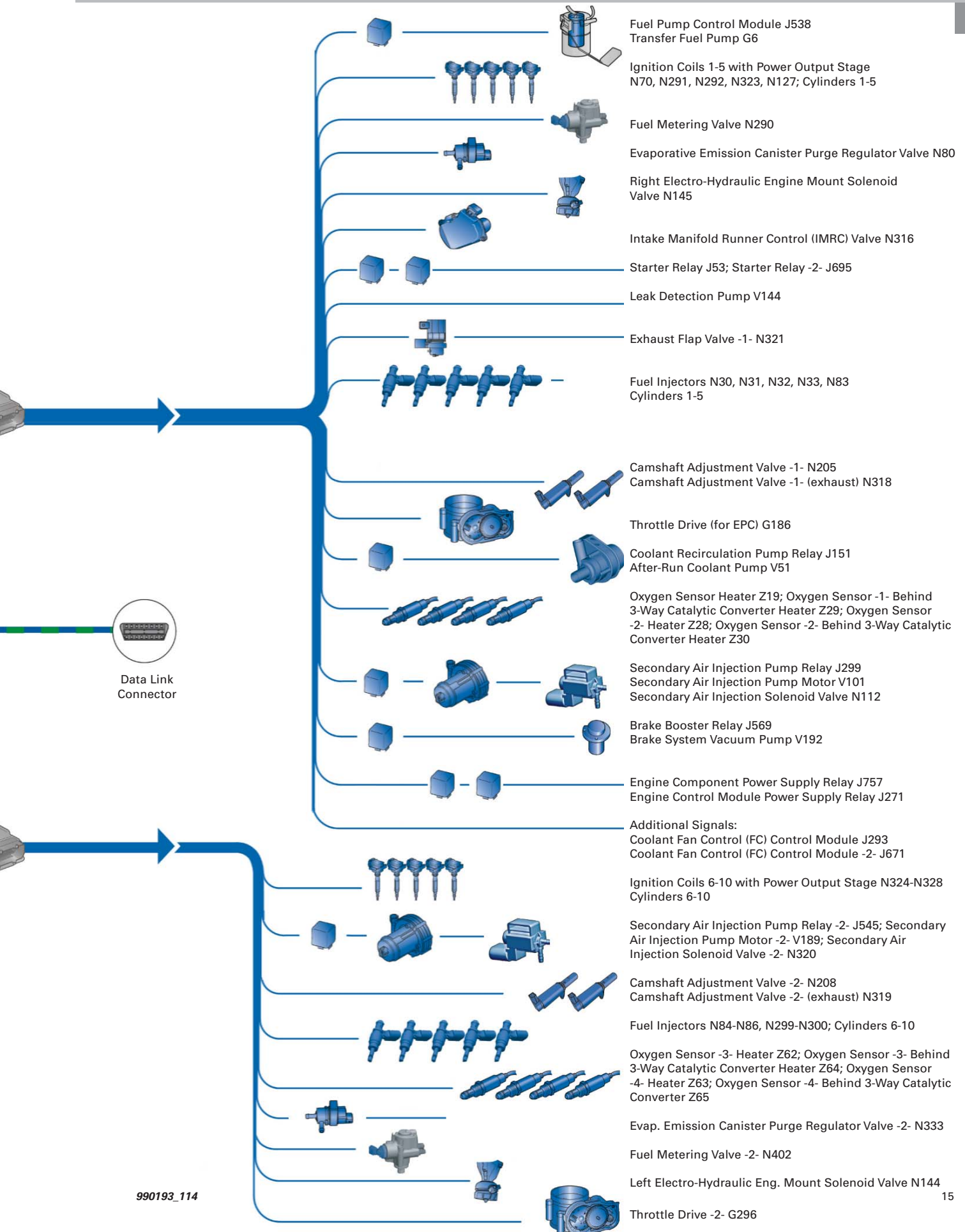

R8 with 5.2L V10 FSI Engine

Distinguishing Features of the 5.2L V10 R8

Audi is the world's first automaker to use LEDs for high beam, low beam, daytime running lights, and turn signals. In this highly complex technology, lens and reflector systems, intelligent ballasts, and fan driven coolers interact. Although the LEDs emit cool light, they heat up, and their temperature must be kept within a defined range.

With a color temperature of 6,000 Kelvin, the LED light closely resembles white daylight, which is less tiring to the eyes when driving at night.

Excellent light distribution and virtually unlimited LED service life are additional benefits. Their energy consumption is also substantially lower than halogen lights.



990193_112

The rear fascia of the R8 5.2L V10 features high-gloss black as the dominant color.

LEDs mounted in tubular housings create a three-dimensional lighting effect.

The rear fascia air outlets have only two cross braces, and the exhaust system terminates in two large, oval tailpipes.

The fully enclosed underbody ends in a diffuser with a pronounced upward sweep.

The rear spoiler automatically deploys at 62 mph (100 km/h.)



990193_111

Packaged Ultrasonic Level Sensor (PULS)

New Oil Level Sensor

A new generation engine oil level sensing system has been introduced by Audi. It is referred to in the technical literature and VAS Scan Tool as: PULS — Packaged Ultrasonic Level Sensor. Vehicles using this system can be identified by the absence of an oil dipstick.

PULS operates on an ultrasonic principle. Ultrasound pulses generated by the oil level sensor are reflected by the oil-air boundary layer. This type of level sensor replaces the older Thermal Oil Level Sensor (TOLS) that used the hot-wire principle.

With PULS, oil level is calculated by the engine control module, which factors the difference between transmitted and reflected pulses of the oil level sensor, and the speed of sound.

The driver can view oil level information via the MMI under the heading CAR. In addition, minimum and maximum oil level warnings are displayed in the Driver Information Display of the instrument cluster.

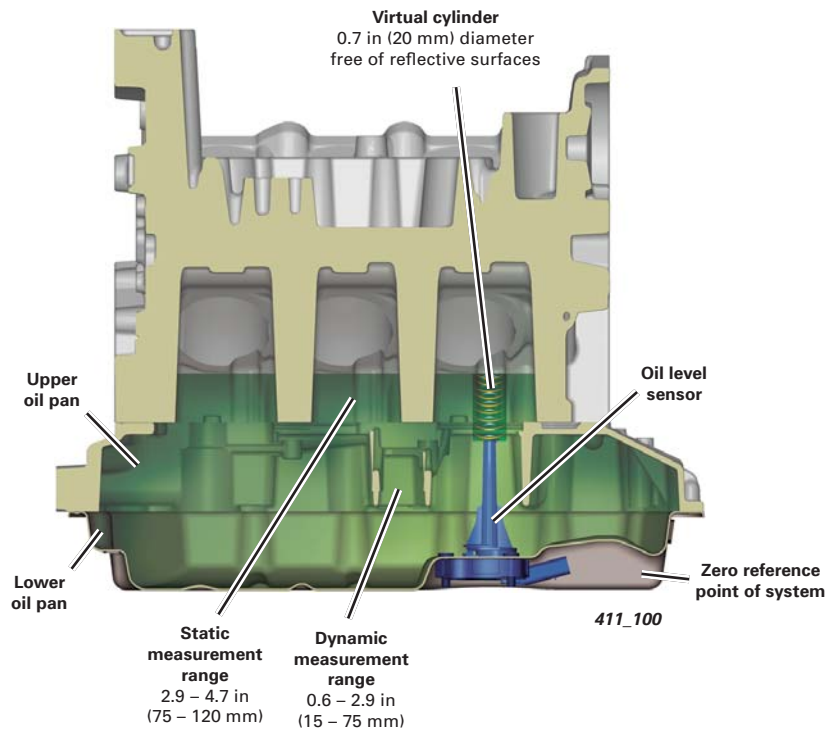

Ultrasonic signals are processed electronically by circuitry in the oil level sensor and are transmitted to the instrument cluster through a Pulse Width Modulated (PWM) signal.

Advantages of the PULS versus a Thermal Oil Level System (TOLS):

- The sensor signal is available quickly (approx. 100 ms for ignition ON)
- Low electrical power consumption (approx. 0.5A)

Packaged Ultrasonic Level Sensor (PULS)

Oil Level Scale

The Engine Control Module calculates oil level in the engine. This information is transmitted to the Powertrain CAN-bus where it is read by the instrument cluster and MMI, which then pass this information on to other sub-systems via Data Bus On Board Diagnostic Interface J533.

Because the dipstick has been eliminated, the customer can only check the oil level via the instrument cluster or MMI displays.

Checking the oil in the workshop requires special tool T40178. The tool must be calibrated for each individual engine. The adjustment ring is first set to the correct position, then the oil level is read on the oil level scale. The correct setting position value for T40178 can be found in the repair manual maintenance section.

Oil level is calculated both dynamically (vehicle moving) and statically (vehicle stationary).

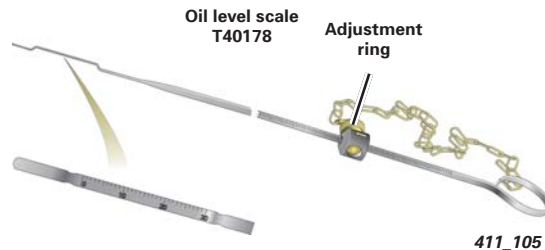

Dynamic Measurement

This measurement method is preferred because it provides more accurate results. The measurement process is interrupted when:

- Vehicle acceleration rate is greater than 6.7 mile/hour seconds (3 meter/sec²)
- Oil temperature is greater than 284°F (140°C)
- Engine hood has been opened

The following criteria are evaluated:

- Engine speed
- Longitudinal and transverse acceleration
- Engine temperature
- Engine Hood Switch F266 position (open/closed)
- Number of miles (km) driven since the last opening of Engine Hood Switch F266 (more than 30 miles [50 km])
- Number of measurement values generated within the driving cycle

Static Measurement

This measurement is performed:

- At ignition ON (however, the signal is transmitted as soon as the driver's door is opened in order to obtain a level signal quickly)
- Engine speed less than 100 rpm
- Engine at standstill for longer than 60 seconds
- Engine temperature over 104°F (40°C)

The longitudinal and transverse acceleration values, as well as the parking brake position are also used to determine vehicle status when measurements are made.

Packaged Ultrasonic Level Sensor (PULS)

Oil level can be checked by the customer using the MMI, under the CAR menu.

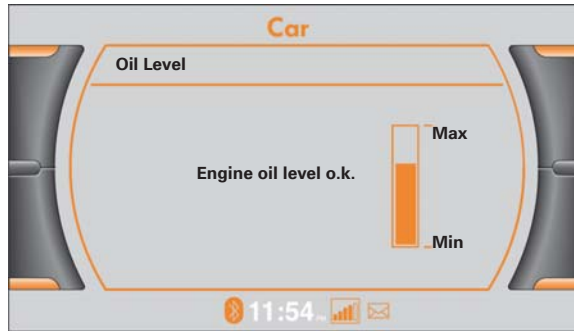

411_096

The following graphics can be displayed in the DIS of the instrument cluster.

In addition, there is a display that indicates overfilling of the system, and a display that indicates if the oil level sensor has failed.



411_097

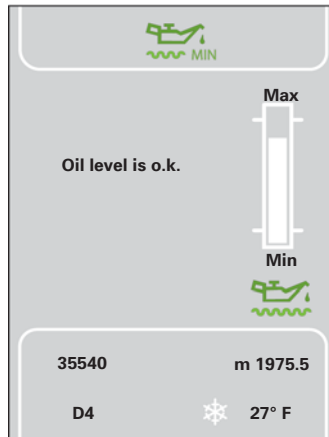

411_098

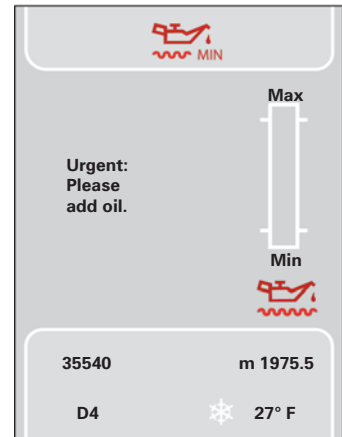

411_099

OB5 S Tronic Transmission

OB5 7-Speed Dual Clutch Transmission

Following the success of the six-speed S tronic on the Audi A3 and Audi TT models, a seven-speed dual-clutch transmission, combined with the quattro powertrain, is now available for the first time in a longitudinal configuration.

The OB5 S tronic transmission combines the positive features of an automatic transmission with the sportiness and efficiency of a manual gearbox. It provides extremely short shift times without interruption of tractive power to provide a special driving experience.

Specifications of the OB5 transmission

Designations	Manufacturer: DL501-7Q Service: OB5 Distribution: S tronic
Development production	Audi AG Ingolstadt VW plant, Kassel
Type	Seven-speed, dual-clutch gearbox; fully synchronized, electro-hydraulically controlled
Dual clutch	Dual oil-cooled multi-plate clutches, electro-hydraulically controlled
Control	Mechatronic system — integrating the hydraulic control module, electronic control module, some sensors and actuators; sport program and “tiptronic” shift program for manual gear shifting
Ratio spread	Up to 8.1 : 1*
Shaft spacing	3.503 in (89.0 mm)
Torque capacity	Up to 406.6 lb ft (550 Nm) at 9000 rpm
Weight	Approx. 313.0 lb (142 kg), including dual-mass flywheel and oil fill

* 7th gear is configured as an overdrive gear. Top speed is in 6th gear.

OB5 S Tronic Transmission

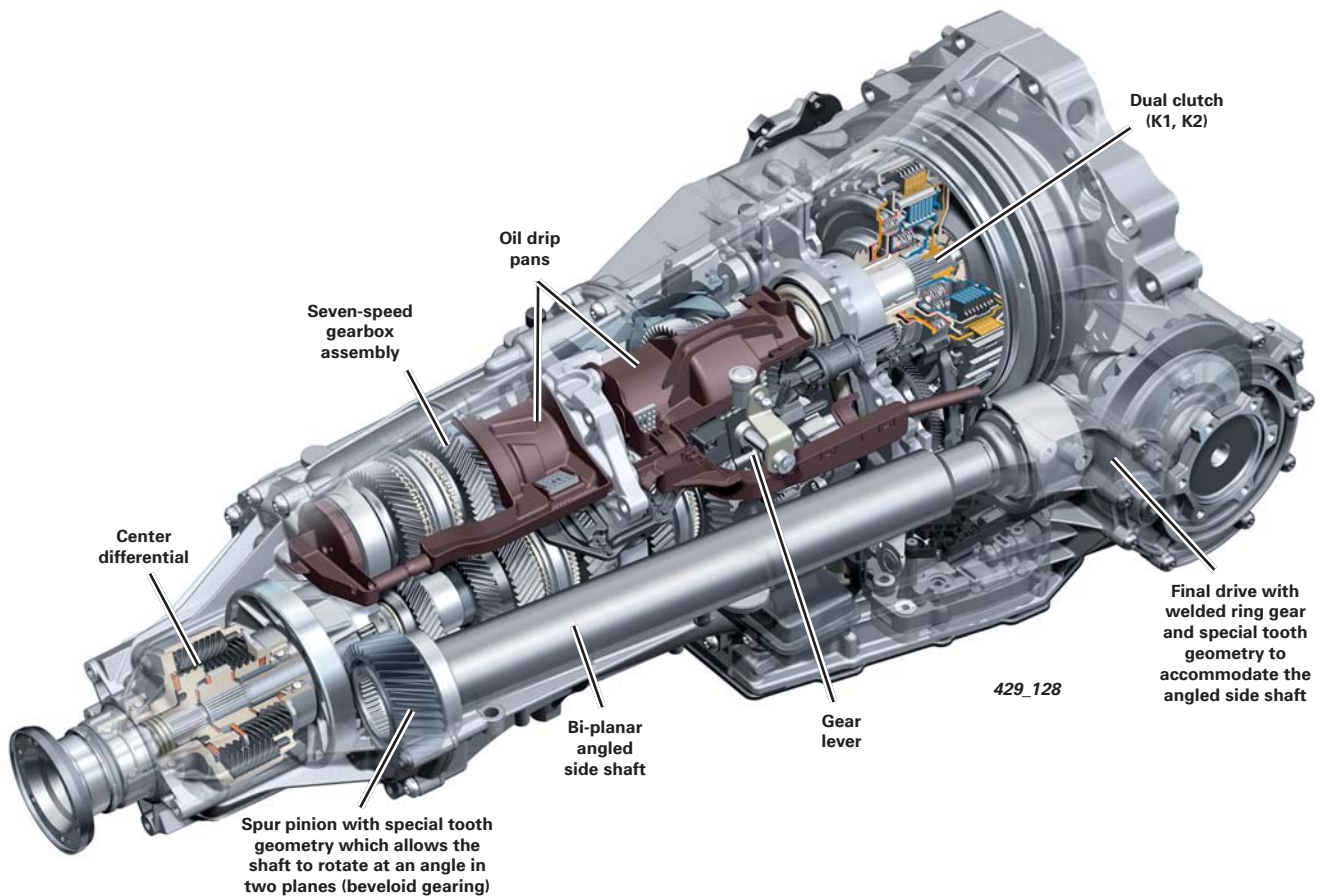
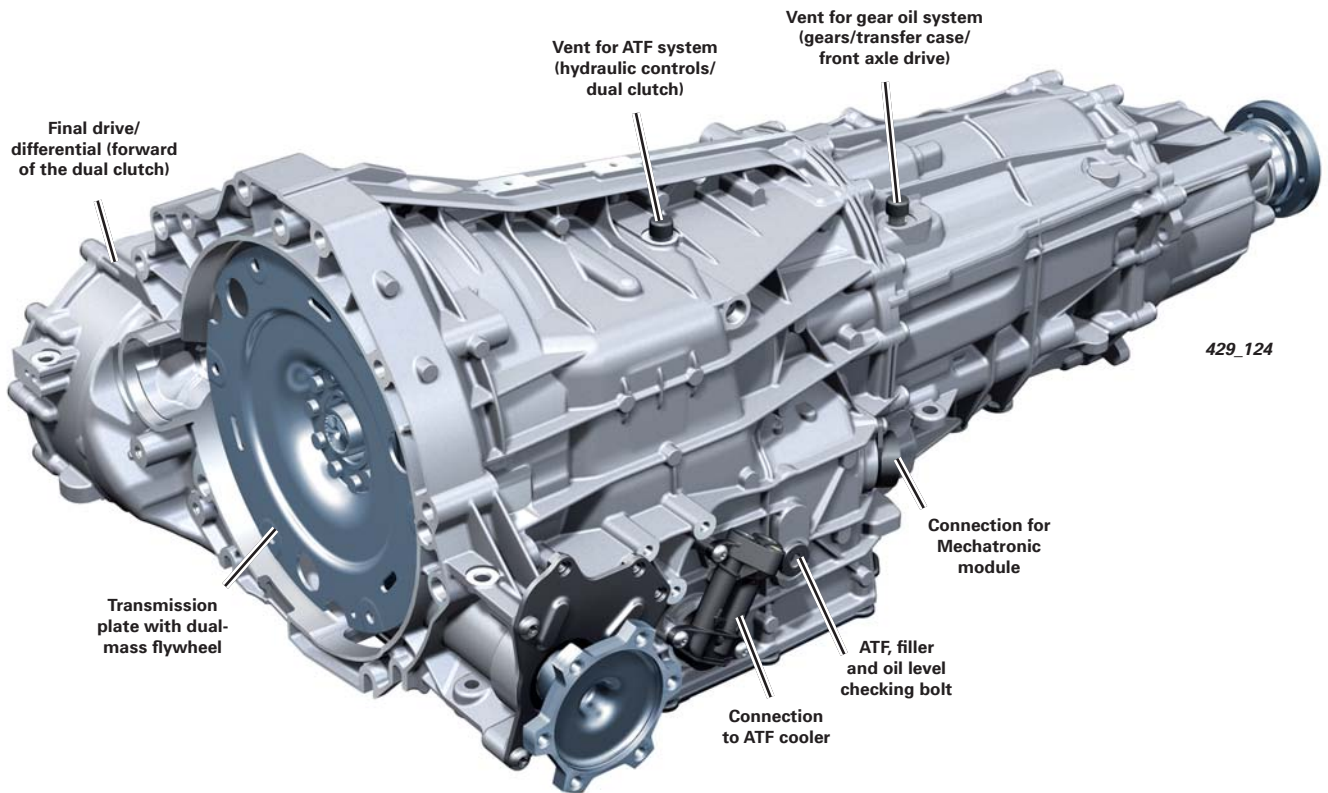

OB5 S Tronic Transmission

Component Parts Overview

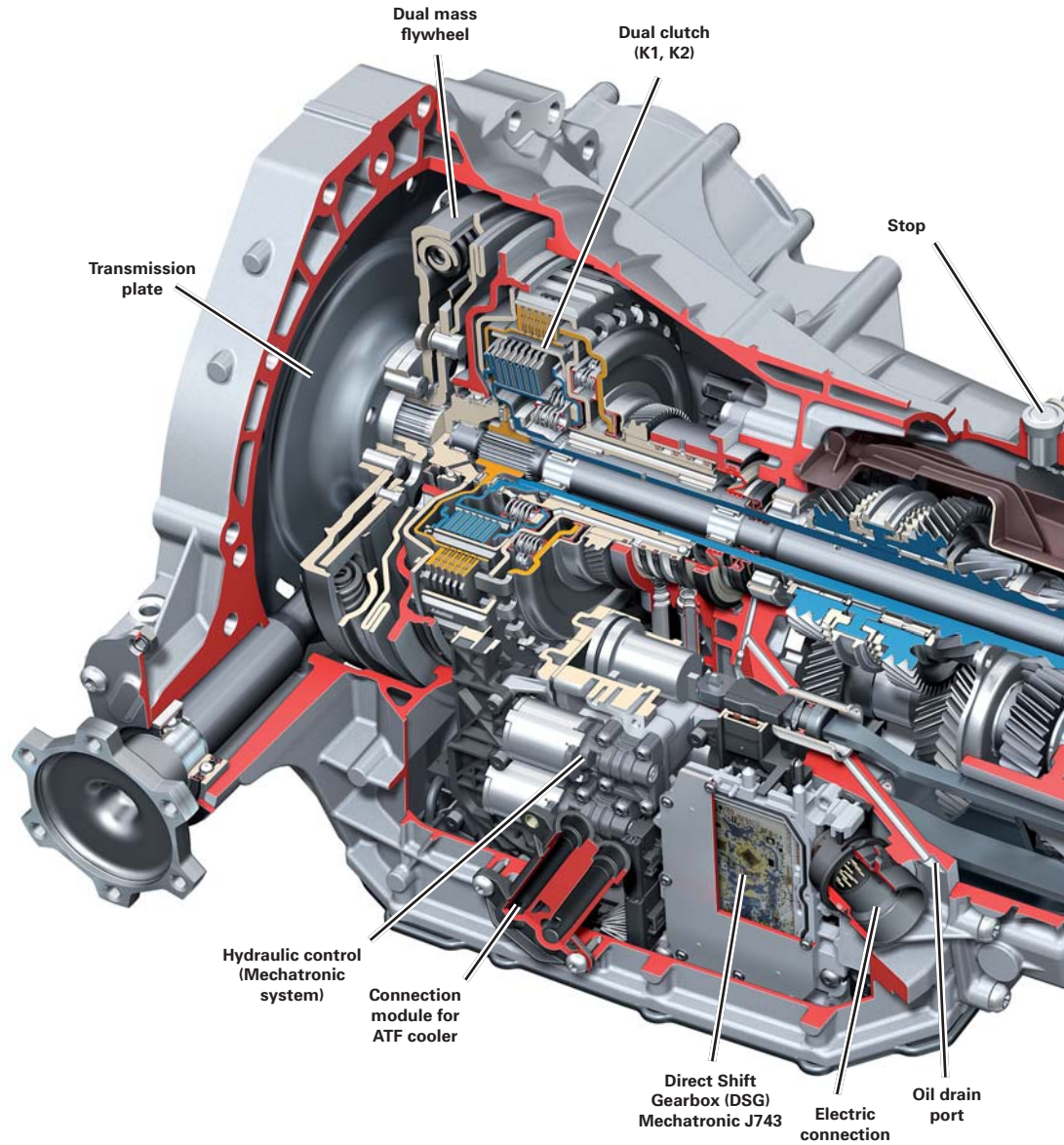

Advantages of Seven Gear Ratios

Seven forward gears provide a wide ratio spread that boosts initial acceleration, while also lowering fuel consumption via the 7th (overdrive) gear.

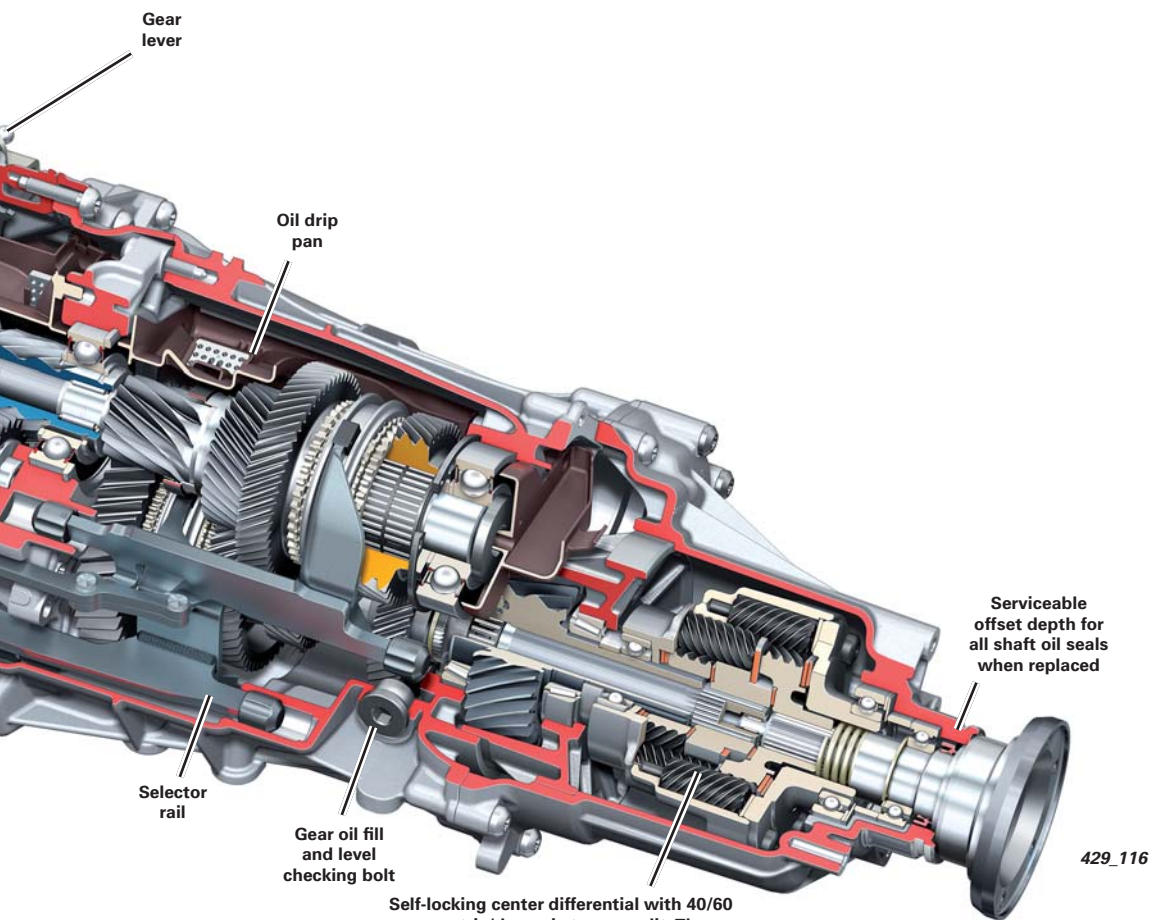

Self-locking center differential with 40/60 asymmetric/dynamic torque split. The asymmetric-dynamic power distribution provides sporty and agile driving characteristics with slight emphasis to the rear axle. When needed, the center differential can deliver up to 85% power to the rear axle or a maximum of 65% power to the front axle.

OB5 S Tronic Transmission

Gearbox Design – Function

Drive is transmitted to the dual mass flywheel through the transmission plate. From there, torque is transmitted to electro-hydraulically controlled clutches (K1, K2) which operate even or odd numbered gears.

The gear arrangement of the 05B transmission can be viewed as two separate gear boxes.

Sub-Gearbox 1

Odd numbered gears (1, 3, 5, 7) are driven through central input shaft 1 by clutch K1.

Sub-Gearbox 2

Even numbered gears (2, 4, 6) and the reverse gear are driven through input shaft 2 (a hollow shaft) by clutch K2.

Power output is through the common output shaft, with torque transmitted directly to the center differential. Torque distribution is approx. 60% to the flange shaft connected to the rear axle, and approx. 40% to the spur pinion and side shaft connected to the front axle drive (not shown here).

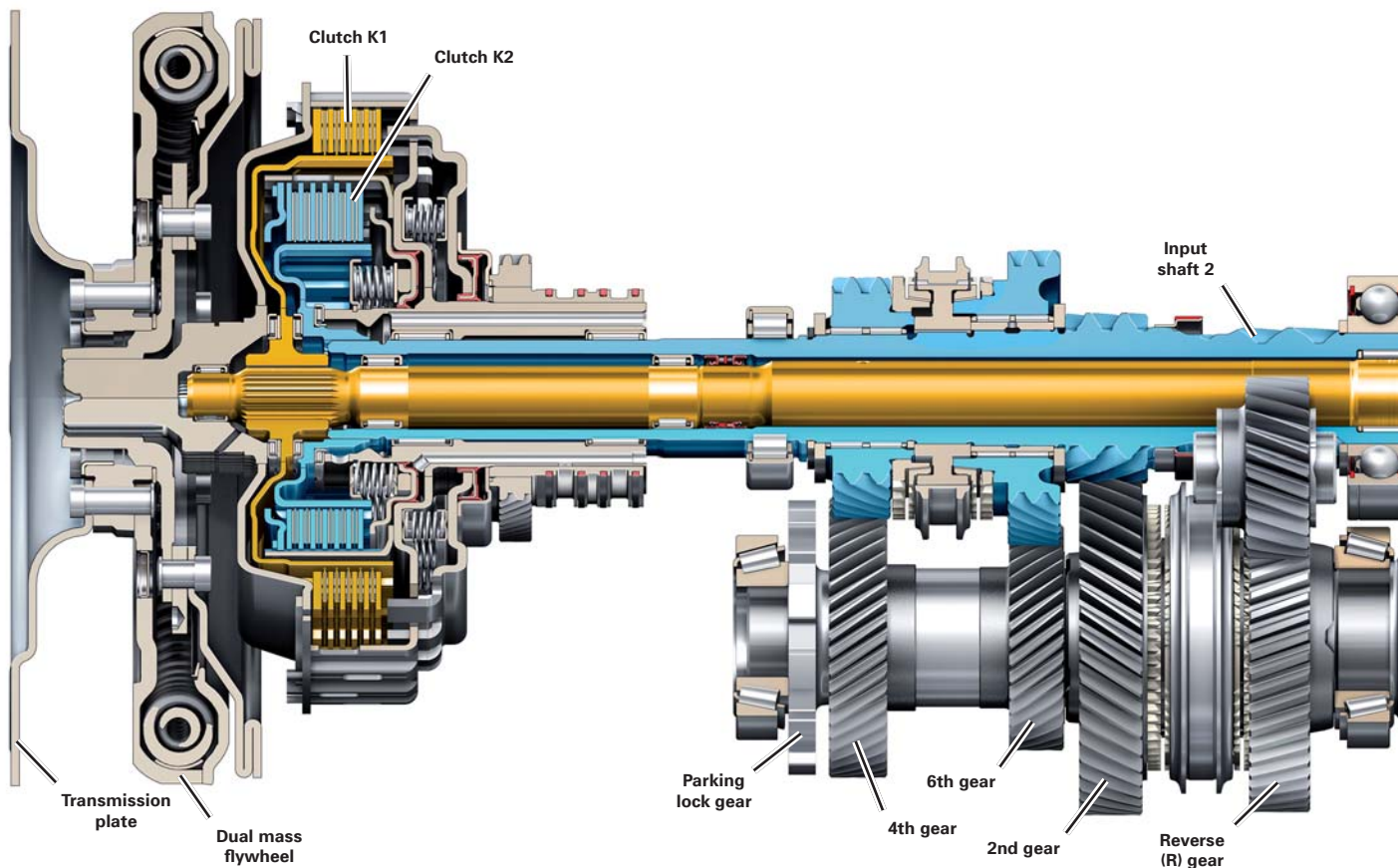

Design Features of the Dual Clutch

The dual clutch serves two tasks:

- To engage the engine at initial acceleration and to disengage the engine when stopping
- To shift the gears

The dual clutch was designed so that clutch K1 is located on the outside, making it a larger diameter. This meets the higher demands placed on K1 as the starting clutch (in first gear).

Small pressure cylinders and coil spring assemblies on both clutches provide good control during initial acceleration and when changing gears.

Hydraulic pressure equalization is no longer required. Clutch control corrects dynamic pressure build-up caused by centrifugal forces at high engine speeds in any situation.

Gear Shifting Sequence

Initial Acceleration

In selector lever position P or N, only 1st gear and reverse are engaged. This allows immediate acceleration from a standing stop. Regardless of whether the driver decides to drive in reverse or to go forward, the correct gears are already pre-selected.

Shifting

To drive forward, the driver shifts the selector lever into D and drives away in 1st gear. When a defined speed threshold of approx. 10 mph (15 km/h) is exceeded, 2nd gear is engaged in sub-gearbox 2 (reverse was previously engaged).

When the shift point for upshifting from 1st to 2nd gear is reached, the gearshift is made by the rapid opening of clutch K1 and simultaneous rapid closing of clutch K2 without any interruption in tractive power. To enhance shift comfort and preserve the clutch, engine torque is reduced during the gearshift (overlap).

The gear shifting process is completed within a few hundredths of a second. 3rd gear is now pre-selected in sub-gearbox 1. The process described above repeats itself alternately during the subsequent gearshifts from 2-3 up to 6-7.

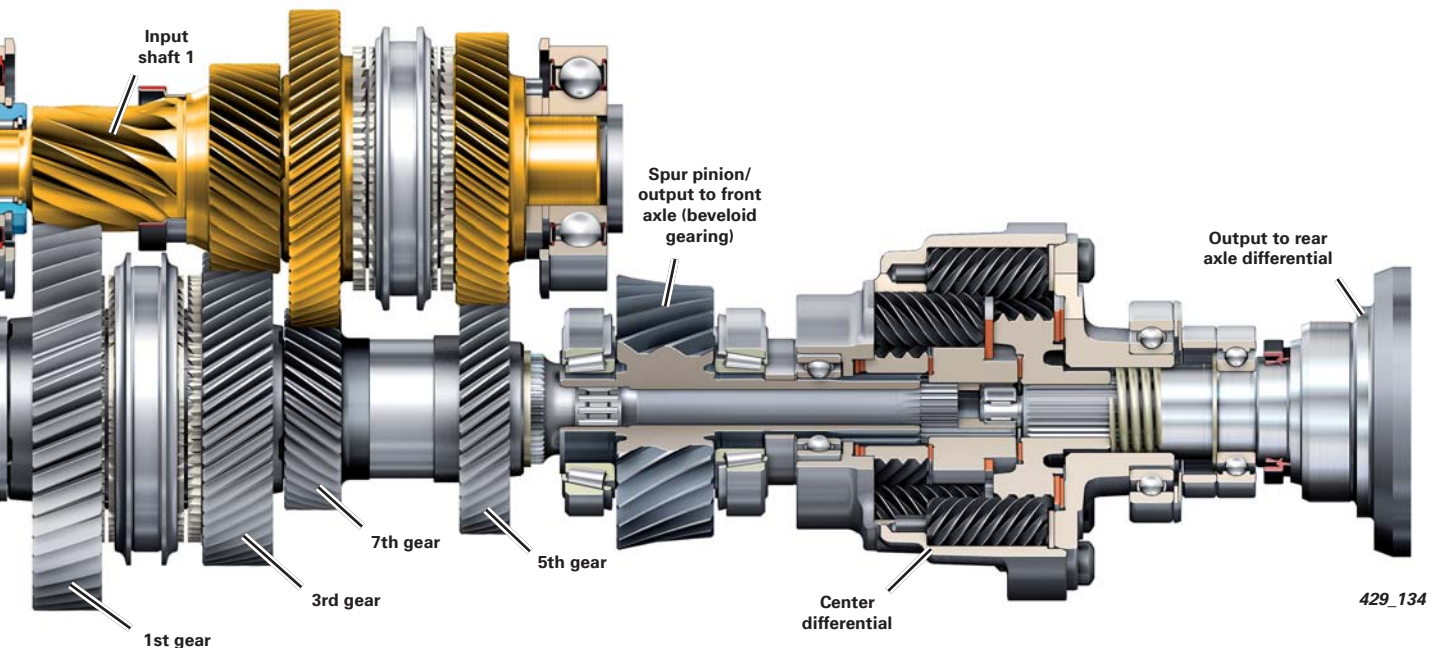

Synchromesh

To facilitate extremely short shift times, all gear synchronizers are carbon coated.

Gears one, two, and three are also triple cone synchronizers due to the high stresses to which they are subjected.

Gears 4, 5, 6, and 7 use single cone synchronizers.

OB5 S Tronic Transmission

Transmission Oil Systems

ATF Oil System

The OB5 transmission has two separate oil systems.

The first oil system accommodates the dual clutch, Mechatronic system, and oil supply. These components use an ATF developed specifically for the OB5 transmission.

This ATF system enables rapid shifting even at low temperatures, while also lubricating and cooling the dual clutch.

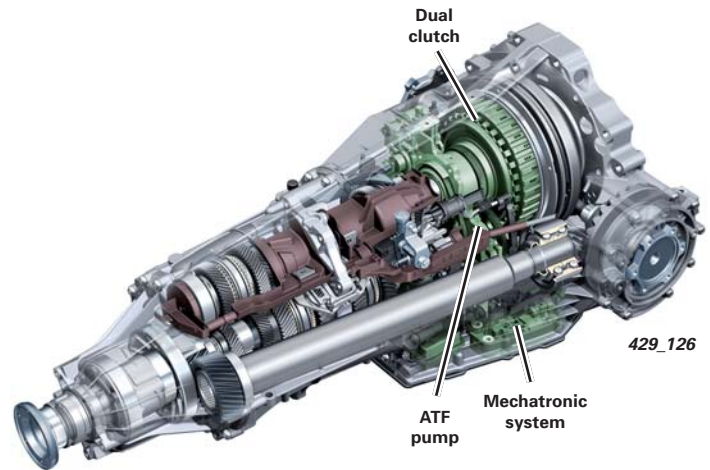

Note



ATF oil is subject to a fixed replacement interval (refer to maintenance).

Hypoid gear oil is designed for lifetime use.

Gear Oil System

The second oil system incorporates the gear assembly, the transfer case (center differential), and the front axle drive.

Lubrication is by means of a hypoid gear oil with a special oil additive for the center differential. Separating these oil chambers made it possible to design the individual component parts of the transmission optimally. It was not necessary to make any compromises due to conflicting demands on the lubricants.

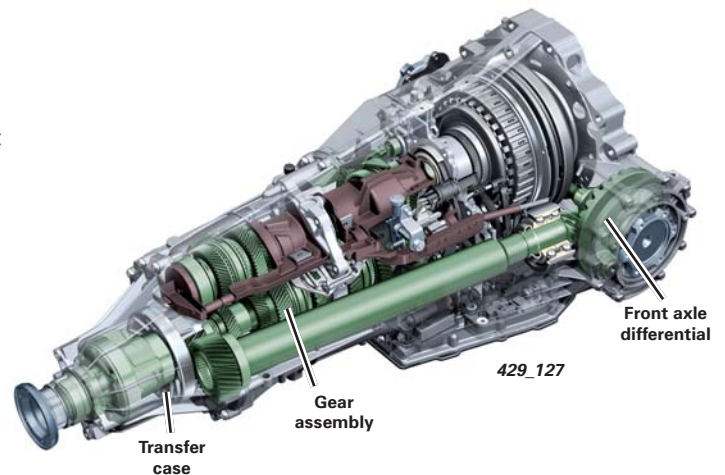

Gear Oil System

The oil chambers must be reliably sealed off from one another.

The ingress of gear oil into the ATF oil chamber (the ATF mixes with the gear oil) would adversely affect the performance of the dual clutch.

To prevent this from occurring, special sealing elements are fitted in relevant places.

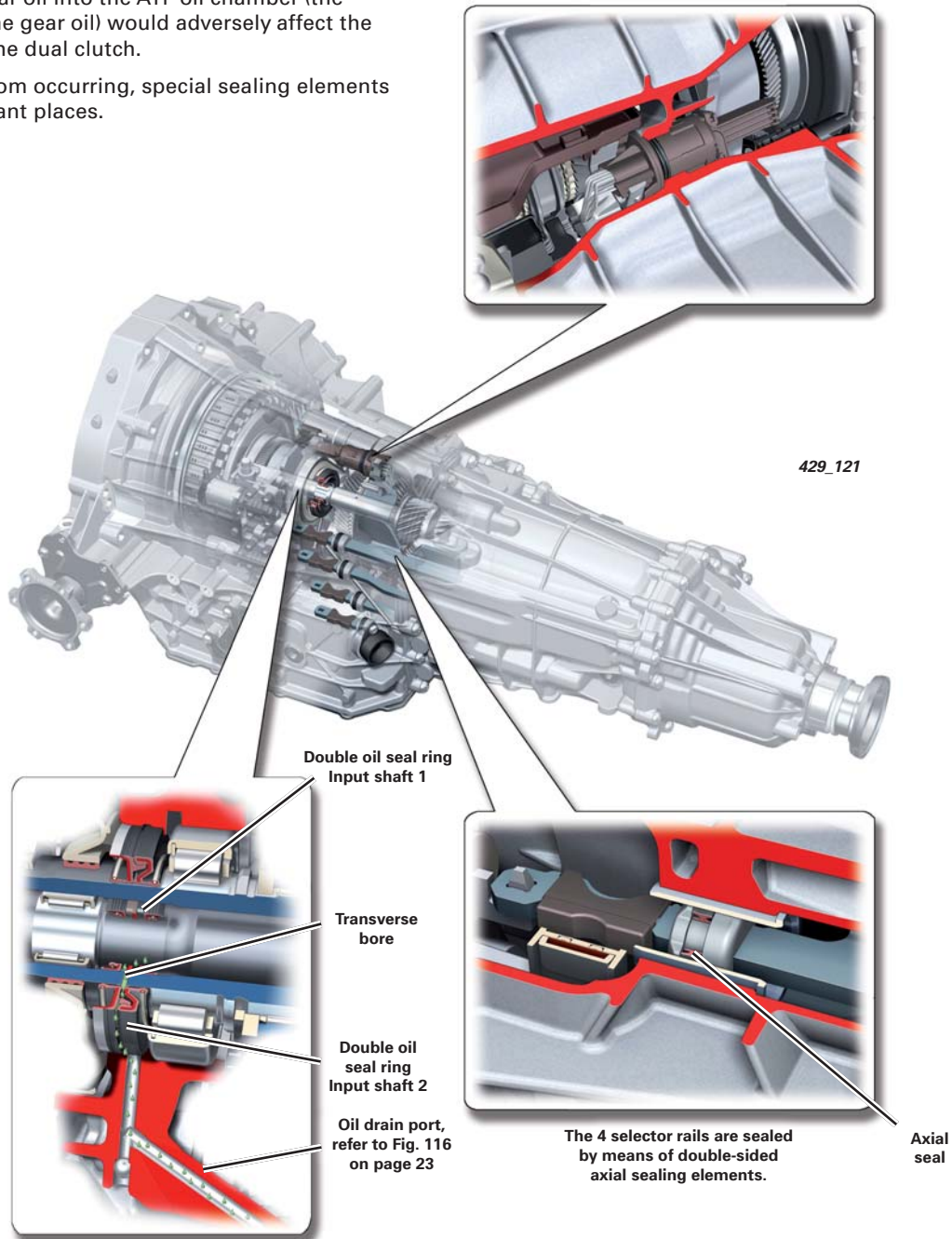

Input shafts 1 and 2 are sealed by a double oil seal ring. In total, four radial sealing rings are used. If a radial seal is leaking, a oil drain port allows the leaking oil to drain off and prevents it from entering the other oil chamber. The transverse bore in input shaft 2 establishes a connection between input shaft 1 and the oil drain port.

ATF Oil Supply – Lubrication

ATF Pump with Rotating Port and Dual Clutch Bearing

A sufficient supply of ATF oil is essential for the operation of the transmission.

An external gear pump driven by the dual clutch through a gear step provides necessary oil flow and oil pressure.

The ATF pump supplies the Mechatronic system with the oil pressure required to perform the following functions:

- Control of the multi-plate clutch (engagement and disengagement)
- Cooling and lubrication of the multi-plate clutch
- Control of gearbox hydraulics

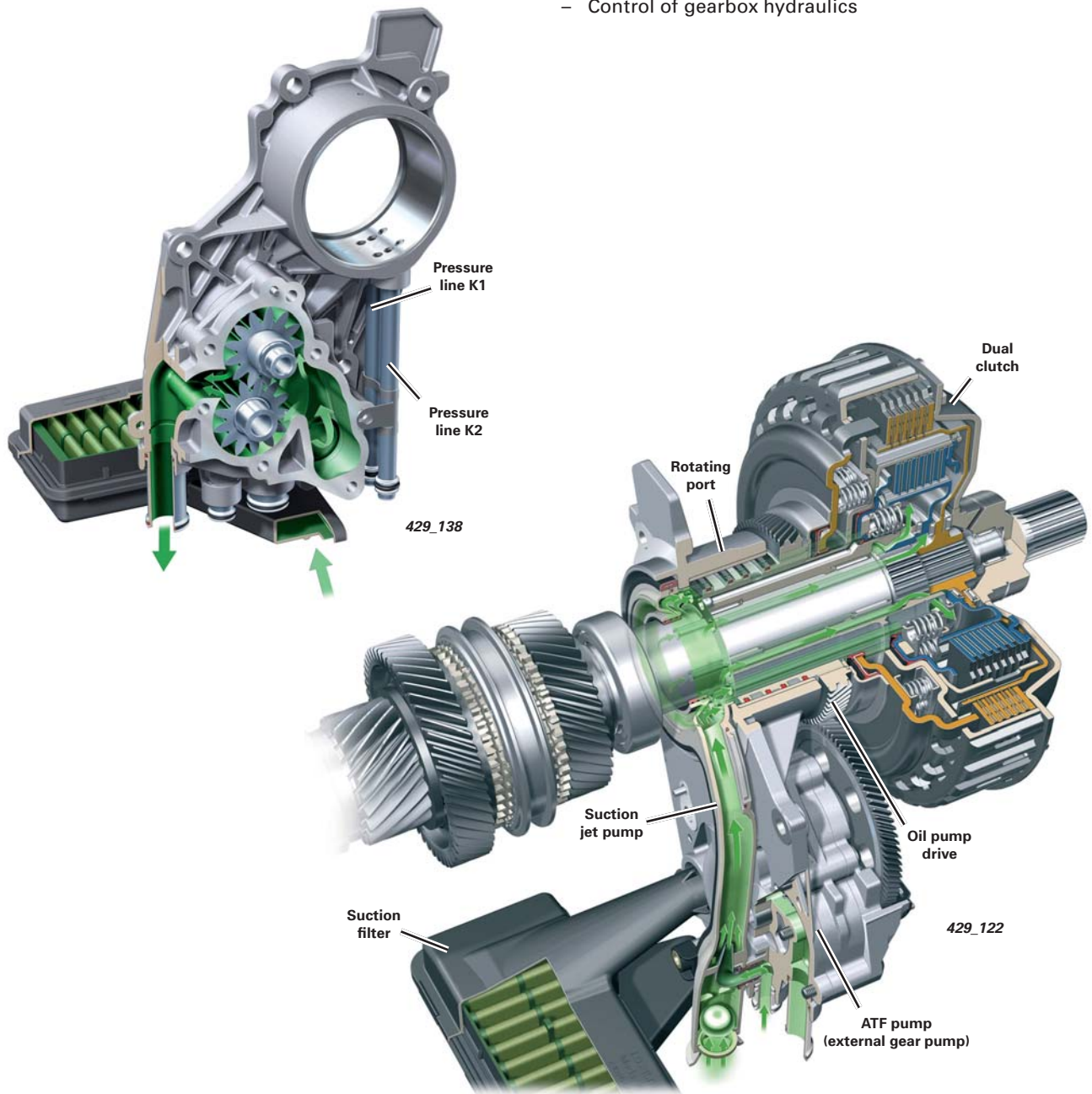

A suction jet pump, operating on the Venturi principle, increases the cooling oil flow for the clutch cooling system. Because this pump doubles the cooling oil flow rate without the need for increasing oil pump capacity, it is smaller and more efficient.

ATF Cooling

ATF cooling is provided by a heat exchanger integrated into the engine cooling system (ATF cooler).

The supply line running to the ATF cooler accommodates a pressure filter, which, in conjunction with the suction filter, provides effective filtering of the ATF. Both filters are designed for lifetime use in the transmission, and are not subject to a replacement interval.

A differential pressure valve is integrated in the pressure filter. It opens when the flow resistance rises above a threshold value, for example when the filter is clogged or the ATF is very cold. Therefore, circulation to the ATF cooler is always assured.

Notes on the ATF cooler:



If the ATF cooler is leaking, coolant will mix with the ATF. Even the smallest amounts of coolant in the ATF will impair clutch control. The new glycol test 8E0 398 998 can be used to determine whether the ATF contains glycol.

Notes on the ATF filter:

It is only necessary to replace the pressure filter if the ATF has been contaminated due to transmission damage. If swarf (metal chips), abraded matter, or other foreign material is found mixed in with the ATF, the ATF cooler must be flushed, and if necessary, replaced.

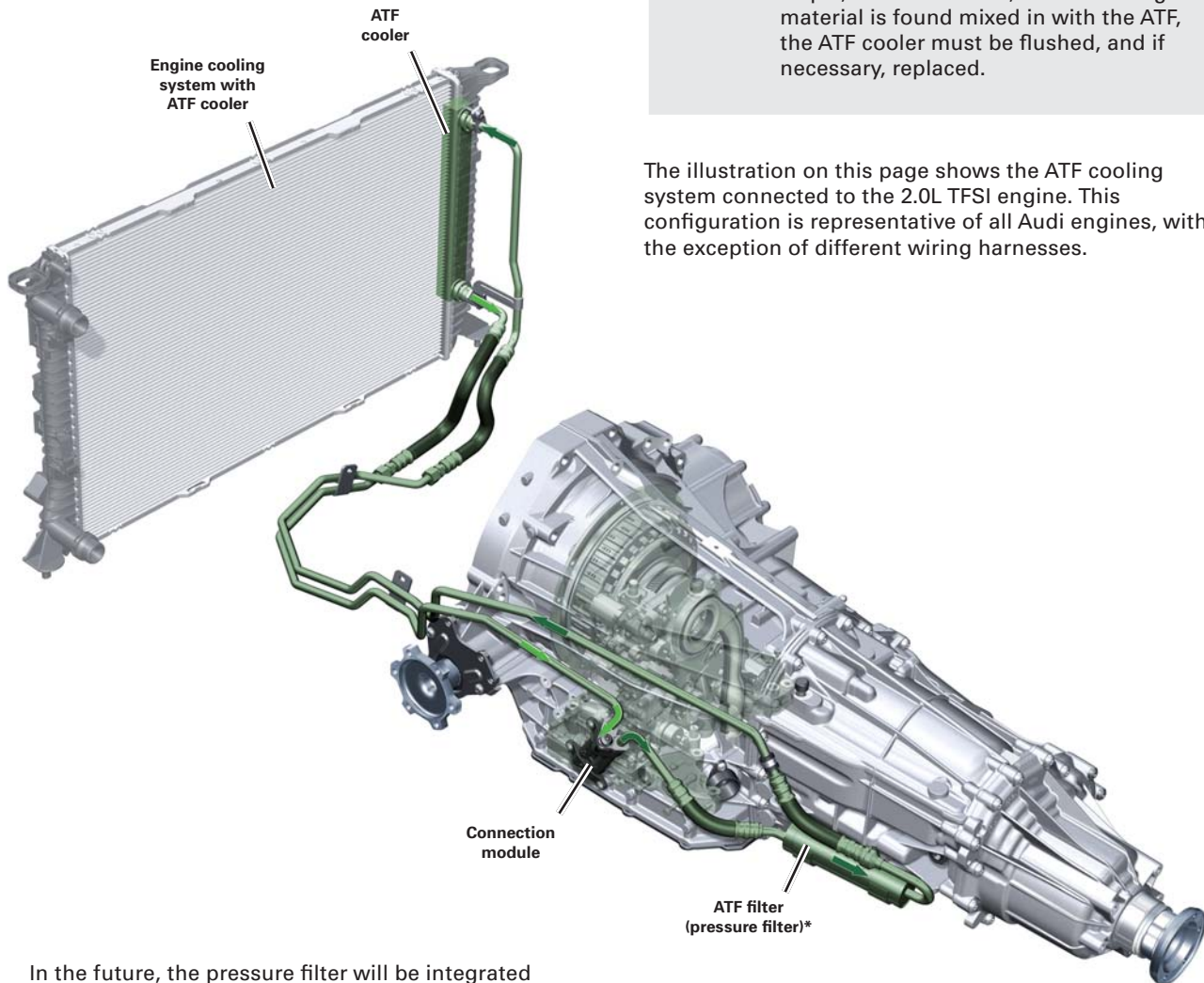

The illustration on this page shows the ATF cooling system connected to the 2.0L TFSI engine. This configuration is representative of all Audi engines, with the exception of different wiring harnesses.

* In the future, the pressure filter will be integrated into the connection module.

OB5 S Tronic Transmission

Gear Assembly Lubrication

Selective lubrication, conducted via special oil passages and oil drip pans, results in lower oil level requirements. This innovative lubrication design reduces churning losses and enhances overall transmission efficiency.

The bearings for the input shaft change gears are lubricated through the hollow drilled input shaft 1. Transverse bores in the shafts direct the oil to the bearing points.

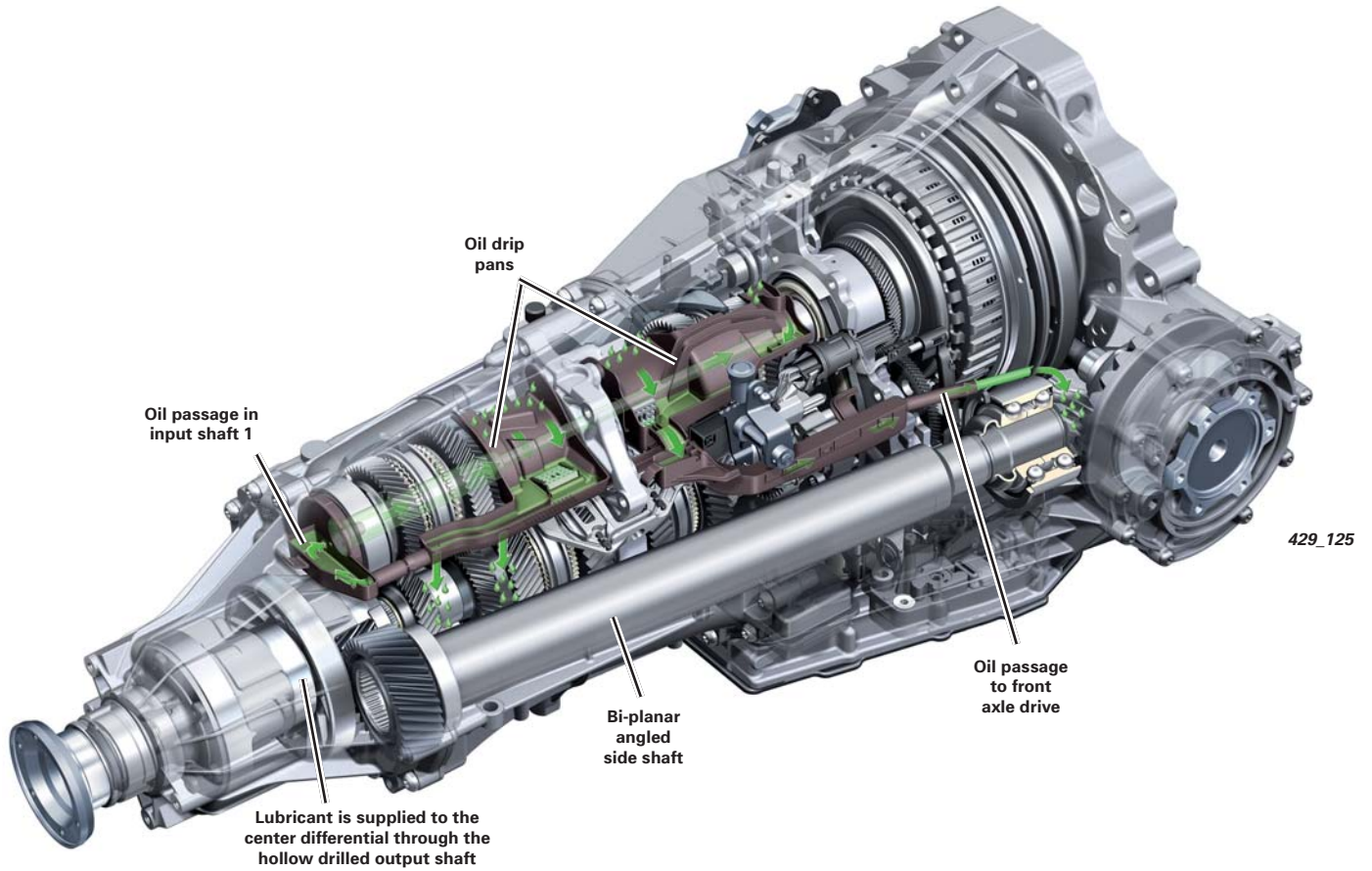

Parking Lock

The 0B5 transmission requires a parking lock since both clutches are open (disengaged) whenever the engine is not running.

The parking lock gear is connected to the output shaft. The pawl is actuated mechanically by the selector lever via the selector lever cable.

Drive Position Sensor G676 is also actuated through the selector shaft and the parking lock lever.

For this purpose, a permanent magnet exerting a magnetic field on the sensor is located on the parking lock actuating lever.

Utilizing the signals generated by Drive Position Sensor G676, the Mechatronic module recognizes the position of the selector lever (P, R, N, D, or S).

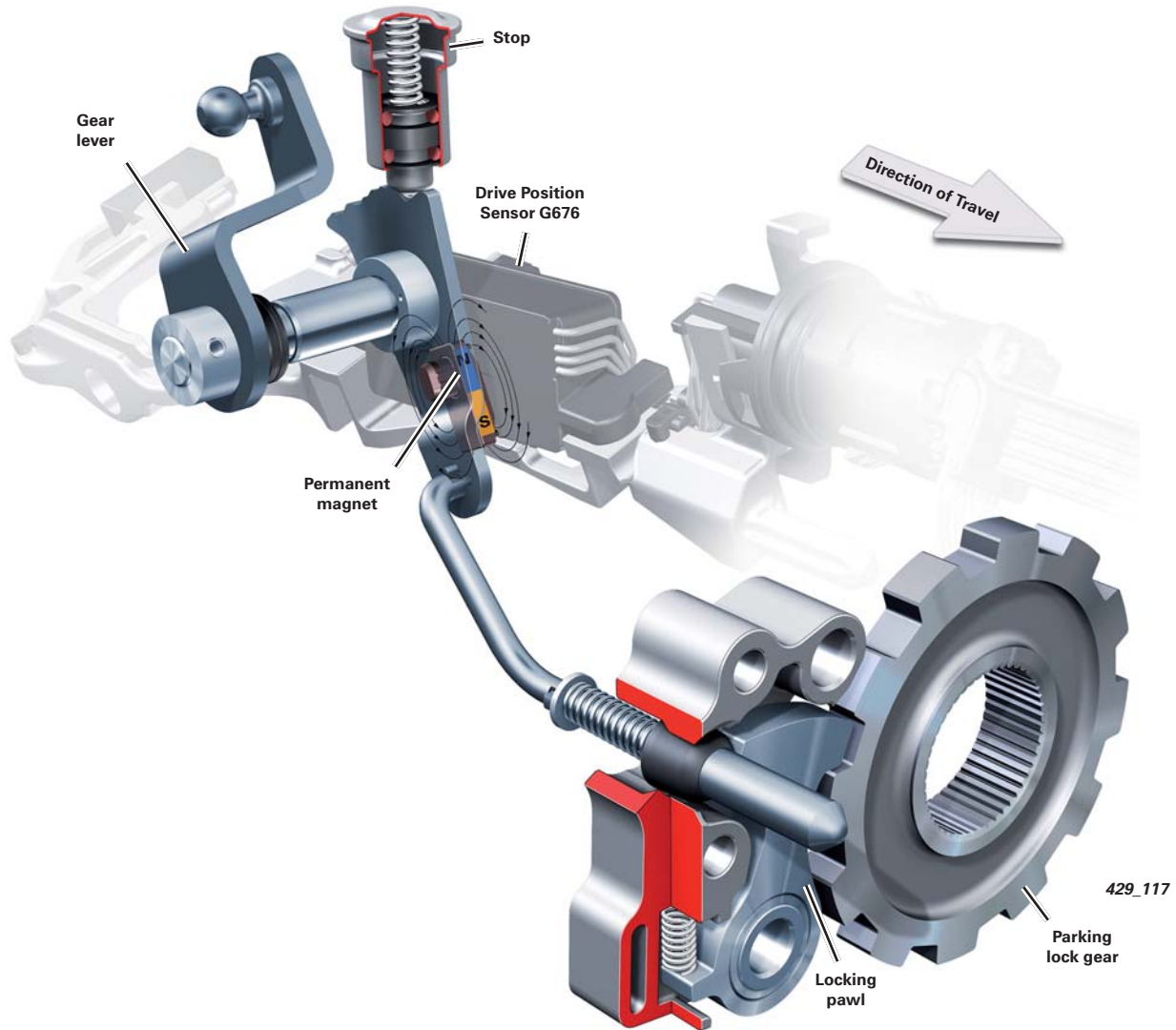

Parking lock in selector lever position P
(locking pawl engaged)



Note

The parking lock gear and pawl lock all four gears through the center differential, but can compensate through the center differential if a raised wheel is able to turn freely, for example, when changing a wheel.

Therefore, as a precaution, the parking brake must always be applied, in these situations.

Transmission Control

Direct Shift Gearbox Mechatronic J743

The transmission is controlled by a newly developed Mechatronic system. It enables precision control of gear engagement speed and force when changing gears. This means that regardless of the driving situation, rapid gear shifts are also smooth.

The Mechatronic system acts as the central transmission control module. It combines the electro-hydraulic control module (actuators), the electronic control module, and some of the sensors into a single unit.

Because of the longitudinal configuration, the rpm sensors of both gearbox input shafts and the gear sensor are located on a separate mounting bracket (PCB 3).

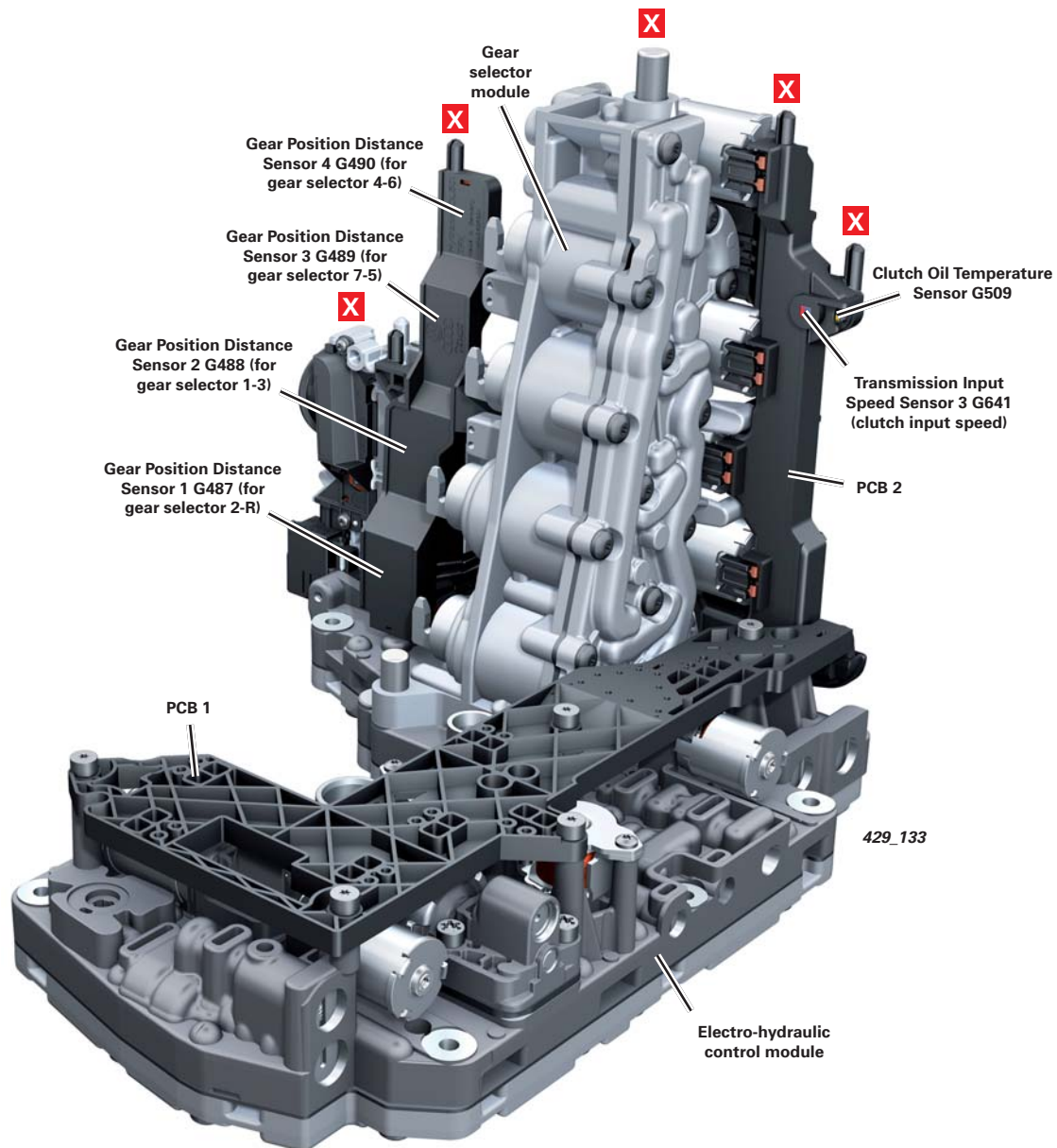

X Mounting points in the transmission case

OB5 S Tronic Transmission

The Mechatronic system controls, regulates, and performs the following functions:

- Adaptation of oil pressure in the hydraulic system to requirements
- Dual clutch regulation
- Clutch cooling regulation
- Shift point selection
- Transmission control and regulation
- Communication with other control modules
- "Limp home" program circuitry
- Self-diagnostics



Note

When replacing the Mechatronic system, various adaptations must be made using the VAS Scan Tool.



Note

When handling the Mechatronic system, it is important to pay close attention to the working guidelines regarding electrostatic discharge!

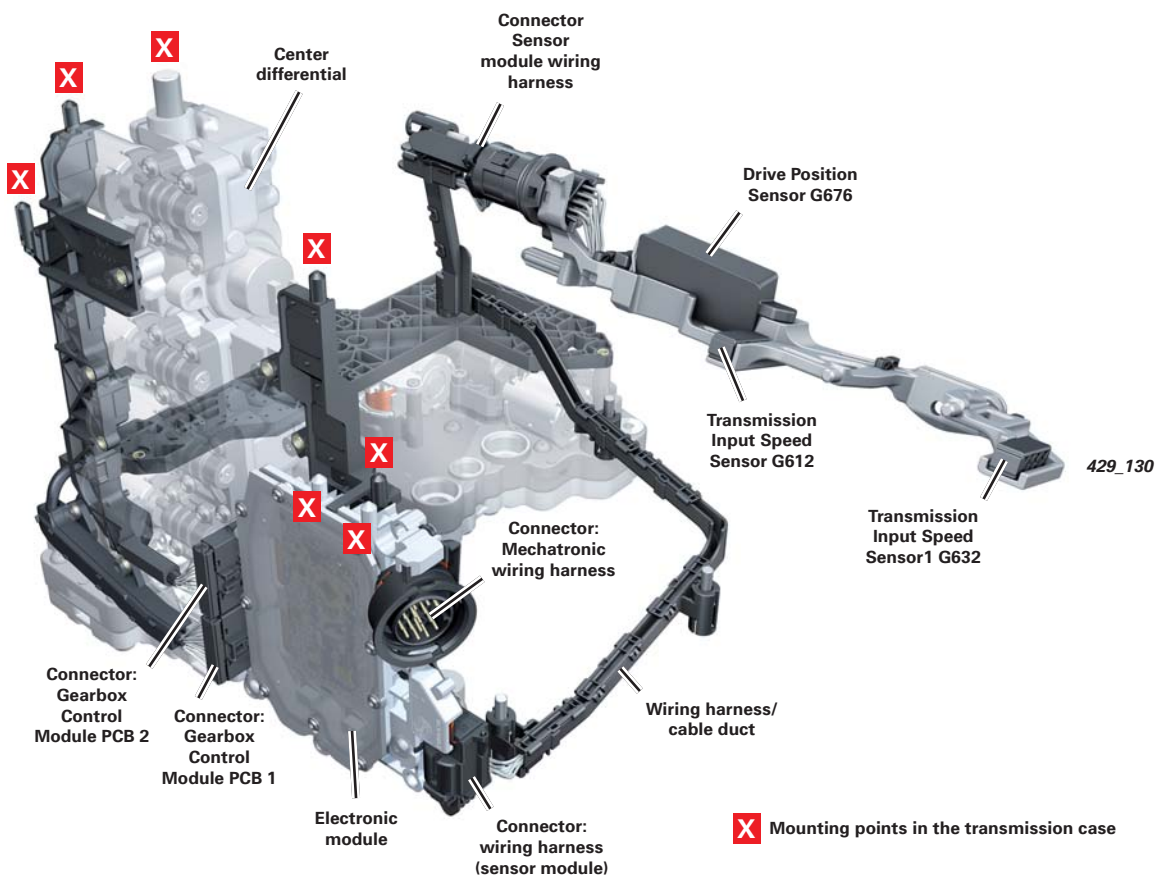

OB5 S Tronic Transmission

Hydraulic Component Overview

This illustration shows the electro-hydraulic control module, together with all components activated by the actuators.

- N433 Sub Transmission 1 Valve 1 (for gear selector 1-3)
 - N434 Sub Transmission 1 Valve 2 (for gear selector 7-5)
 - N435 Sub Transmission 1 Valve 3 (for clutch valve K1, activation)
 - N436 Sub Transmission 1 Valve 4 (for pressure regulation in sub-gearbox 1)
 - N437 Sub Transmission 2 Valve 1 (for gear selector 2-R)
 - N438 Sub Transmission 2 Valve 2 (for gear selector 4-6)
 - N439 Sub Transmission 2 Valve 3 (for clutch valve K2, activation)
 - N440 Sub Transmission 2 Valve 4 (for pressure regulation in sub-gearbox 2)
 - N471 Cooling Oil Valve
 - N472 Main Pressure Valve
- GS = Gear Selector

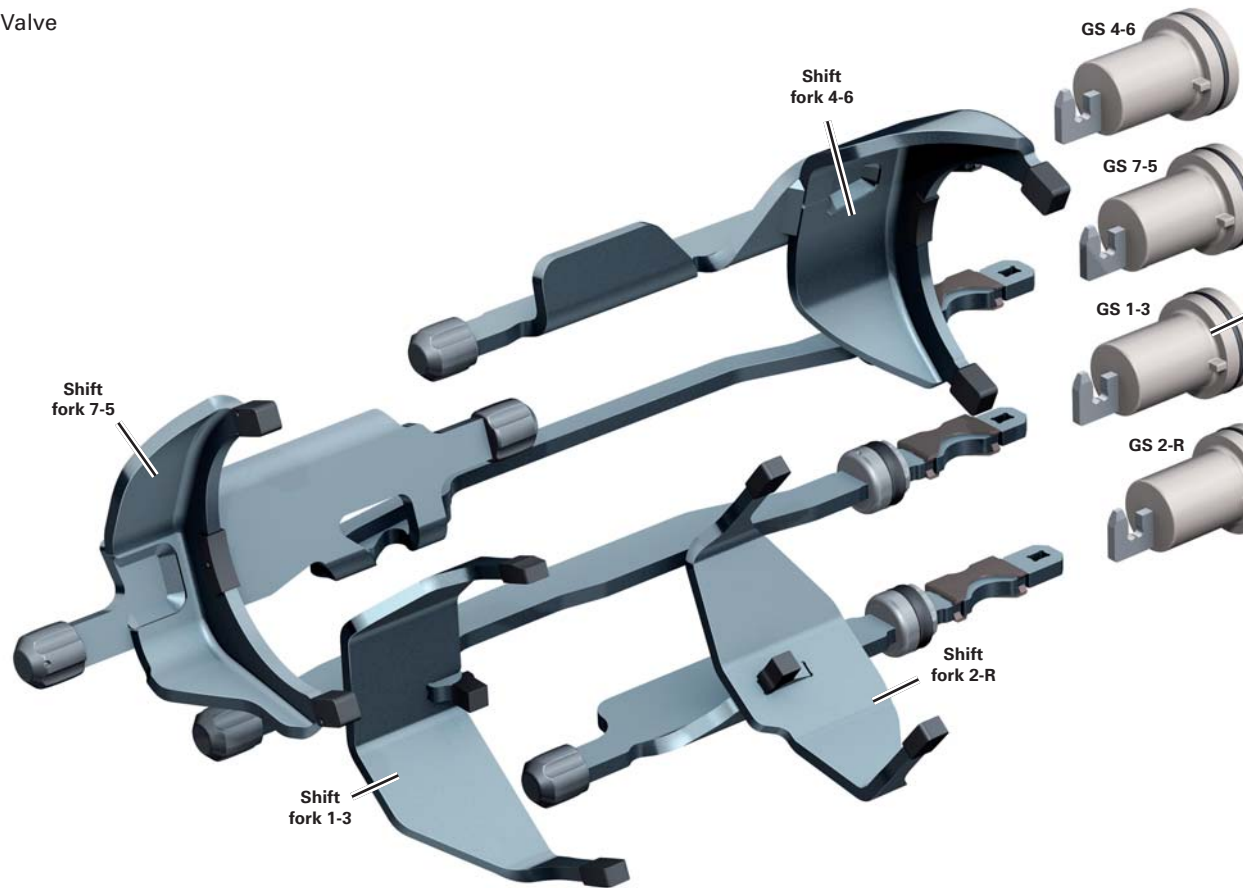

Note

Before installing the Mechatronic system into the transmission, the gear selectors and selector rails must be brought into alignment with each other. Refer to the repair manual.

The selector rails/shift forks have no stops, with the shift forks held in position by gear selectors. The only stops are in the gear change sleeve and the synchronizer assembly.

OB5 S Tronic Transmission

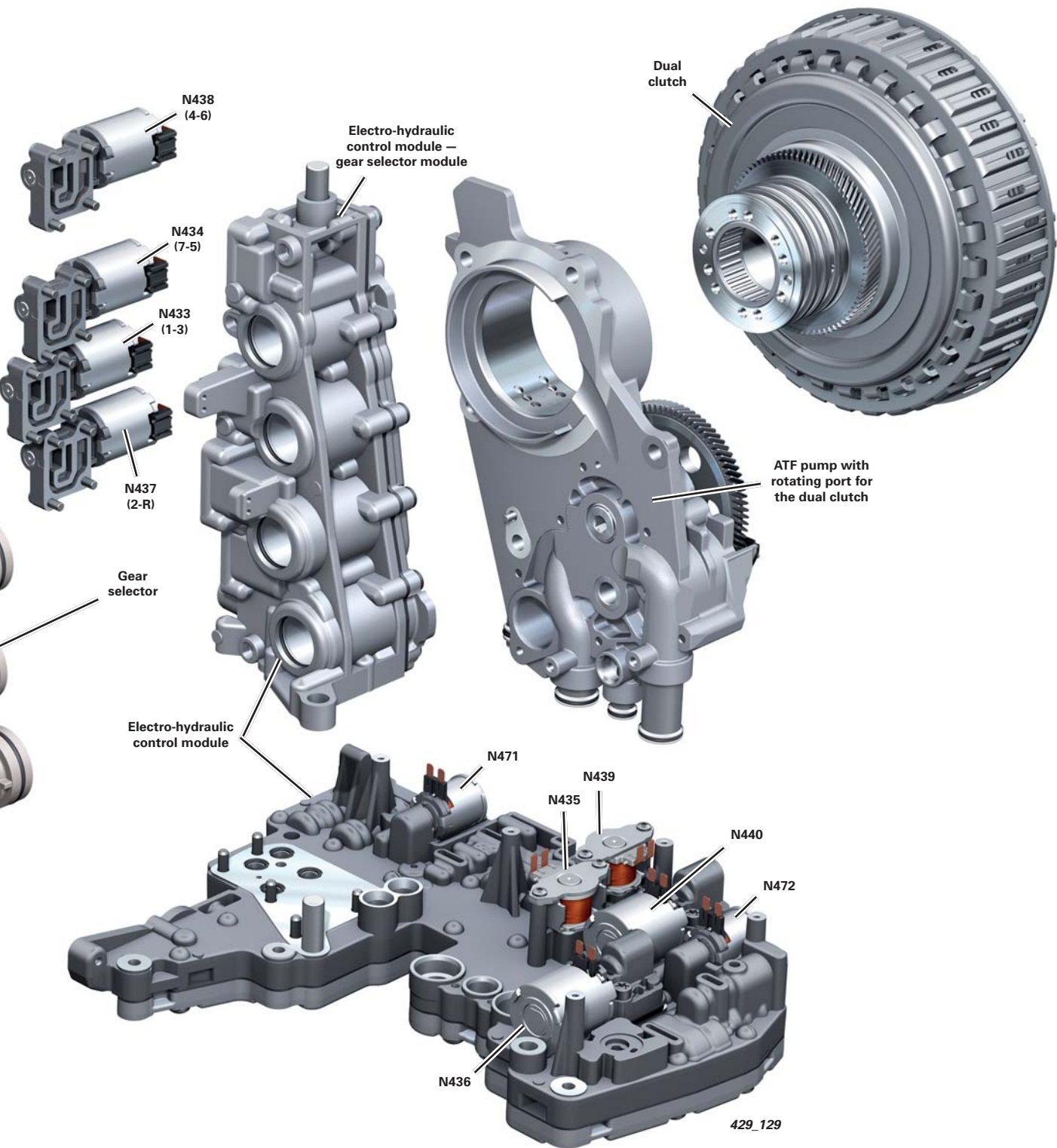

OB5 S Tronic Transmission

Electronics

Integrated Sensors

The transmission control module, the four distance sensors and the two hydraulic pressure sensors are combined as a non-separable unit.

Two temperature sensors are integrated into the TCM. One sensor is positioned to supply precise ATF temperatures.

The other sensor is integrated directly into the processor and measures critical component temperatures.

The two temperature senders monitor each other for plausibility. Electronics temperature monitoring is very important so that temperature reduction measures can be made quickly, as needed.

Besides safety, ATF temperature is relevant to both clutch control and hydraulic control. For this reason, ATF temperature is also a key factor in control and adaptation functions.

Automatic Transmission Hydraulic Pressures Sensors 1 and 2 are utilized for clutch pressure monitoring and for adaptation of the primary pressure and sub-gearbox pressures.

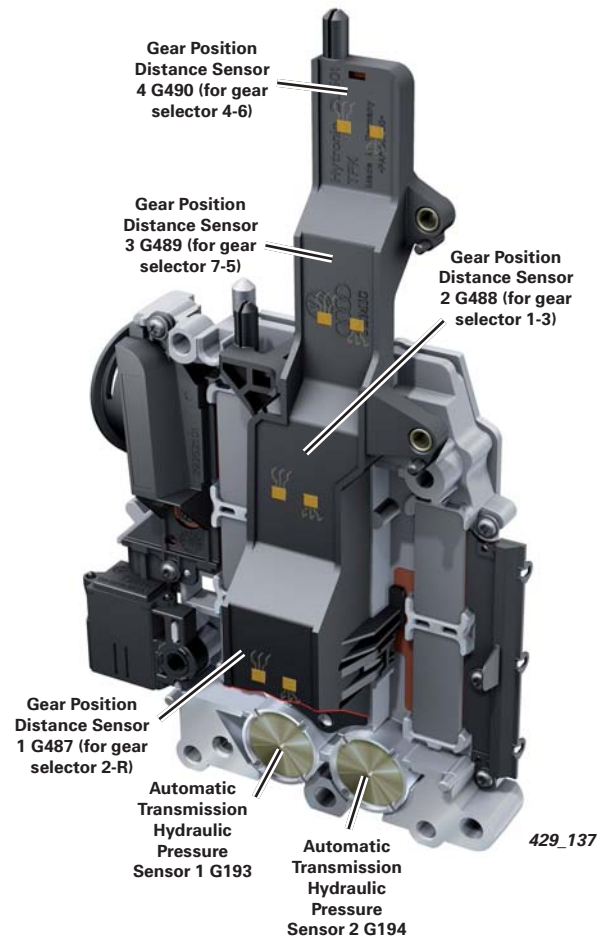
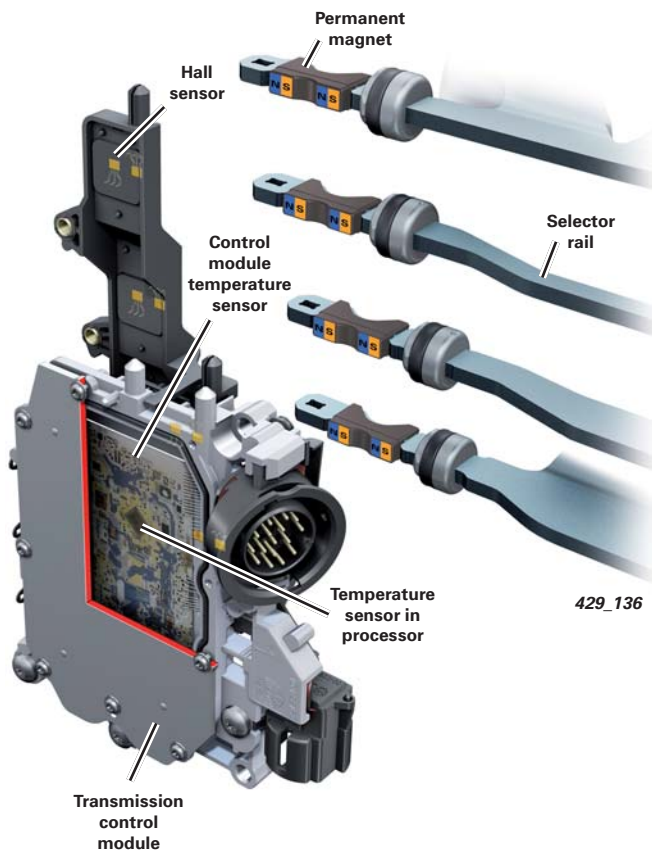

Four distance sensors determine the position of each selector rail/shift fork. The TCM requires this information to immediately diagnose non-allowed positions and to activate a “limp home” program, if necessary.

An exact travel measurement is also essential for precision gear shifting. The various phases of the synchronization and gearshifting processes can then be activated sequentially.

A distance sensor consists of two Hall sensors and two permanent magnets which are attached to the selector rail. Depending on the position of the magnets in relation to the Hall sensors, the Hall sensors output a voltage which corresponds to the distance traveled. The travel signal is generated by evaluating both voltage signals.



Note

To measure the precise distance traveled by the gear selector, the shift mechanism must be adapted to the transmission control module using the VAS Scan Tool.

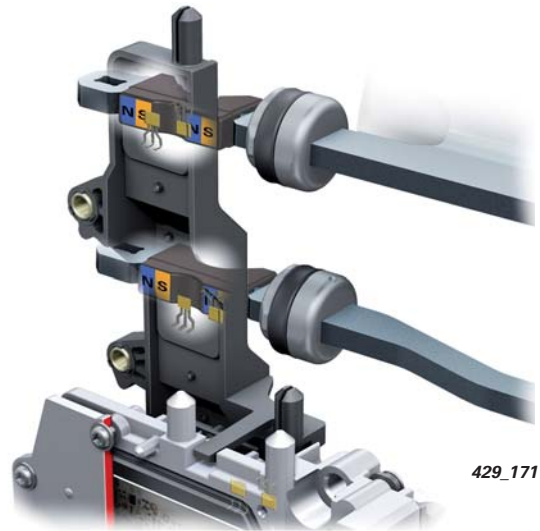

Separate Sensors

Transmission Input Speed Sensors 1 and 2, as well as the gear sensor are mounted together on a common mounting bracket (PCB 3).

Both engine speed senders are "intelligent sensors." With three Hall sensors and the corresponding evaluation electronics, it is possible to distinguish between driving forward, driving in reverse, and a weak magnetic field. The control module receives the information from the senders pre-evaluated in the form of a pulse width modulated signal.

The various states are indicated to the control module by different pulse widths. For example, when driving forward, the engine speed signal has a different pulse width than when reversing.

Signal Use

- Determination of the clutch output speed for computing clutch slip
- Determination of the synchronization speed for shift control

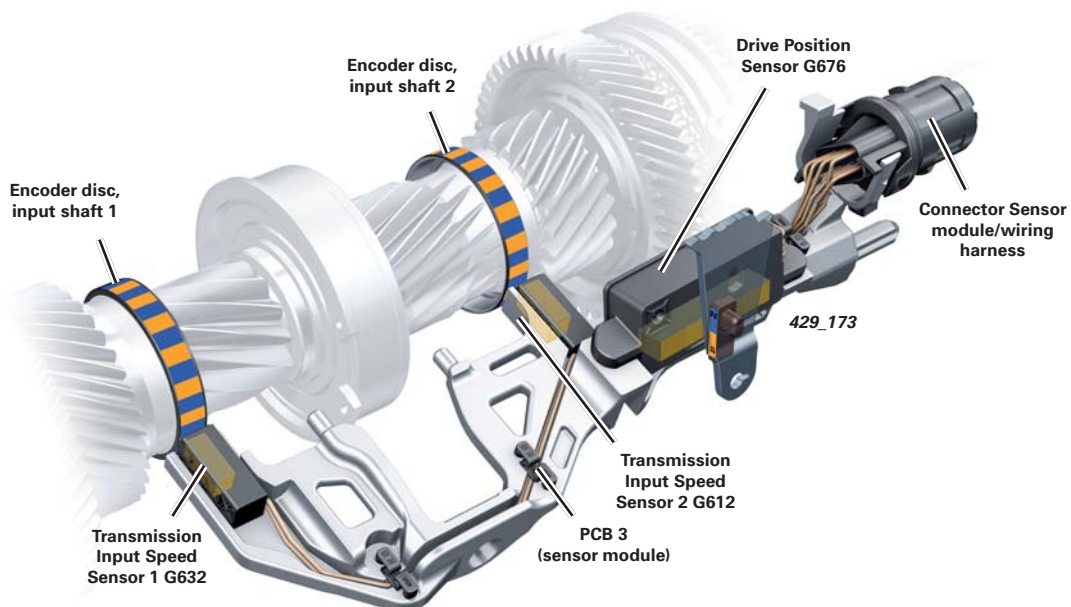

OB5 S Tronic Transmission

Drive Position Sensor G676

G676 is located in the gearbox and is an integral part of the sensor module. This is a contactless travel sensor which is used to determine the selector lever positions (P, R, N, D, and S).

A permanent magnet exerting a magnetic force on the gear sensor is located on the parking lock lever. The parking lock lever is connected to the gear lever by a shaft. It is actuated by the selector lever by means of a selector lever cable.

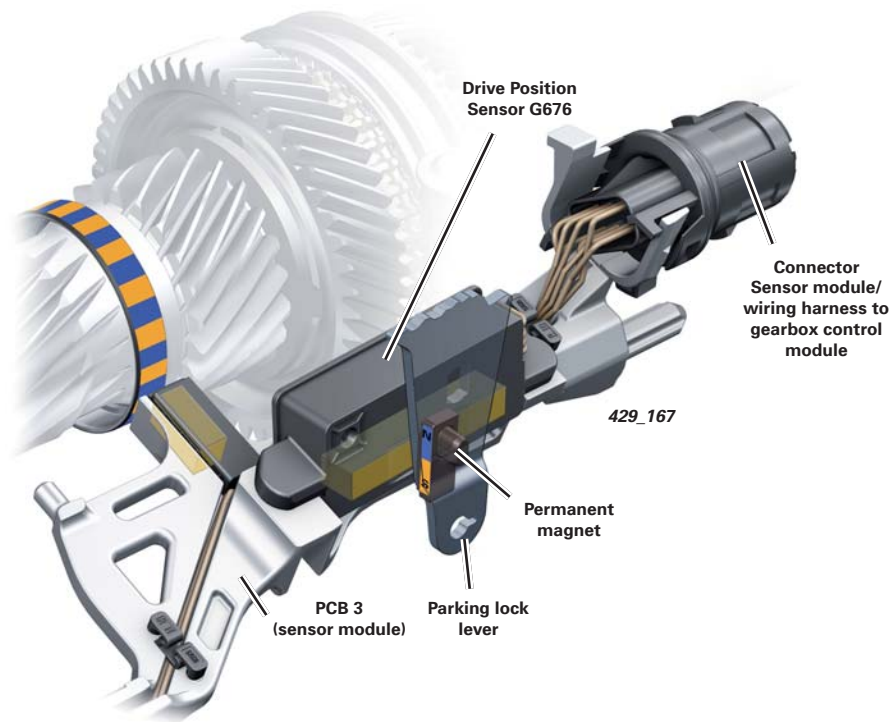

The transmission control module requires data on selector lever position to perform the following functions and generate the following signals and information:

- Information on driver input/vehicle operating state (forward, reverse, neutral) for activation of the clutches and gear selectors
- Information for selection of shift program "D" or "S"
- Signal for controlling the starter inhibitor
- Signal for controlling the P/N lock (shift-lock)
- Information for reverse gear (for example, back-up lights, Park Assist System, etc.)
- Control of the selector lever position indicator in the instrument cluster and gearshift mechanism

The position sensor is a PLCD travel sensor. The abbreviation PLCD stands for Permanent Magnetic Linear Contactless Displacement sensor and describes a contactless sensor which measures linear travel using a permanent magnet.

The signal generated by this sensor is very important for gearbox control and is safety-critical. For this reason, G676 consists of two redundant sensors arranged in parallel.

The TCM always evaluates both sensors.



Note

The gear sensors must be adapted to the transmission control module using the VAS Scan Tool.

Transmission Input Speed Sensor -3- G641 and Clutch Oil Temperature Sensor G509

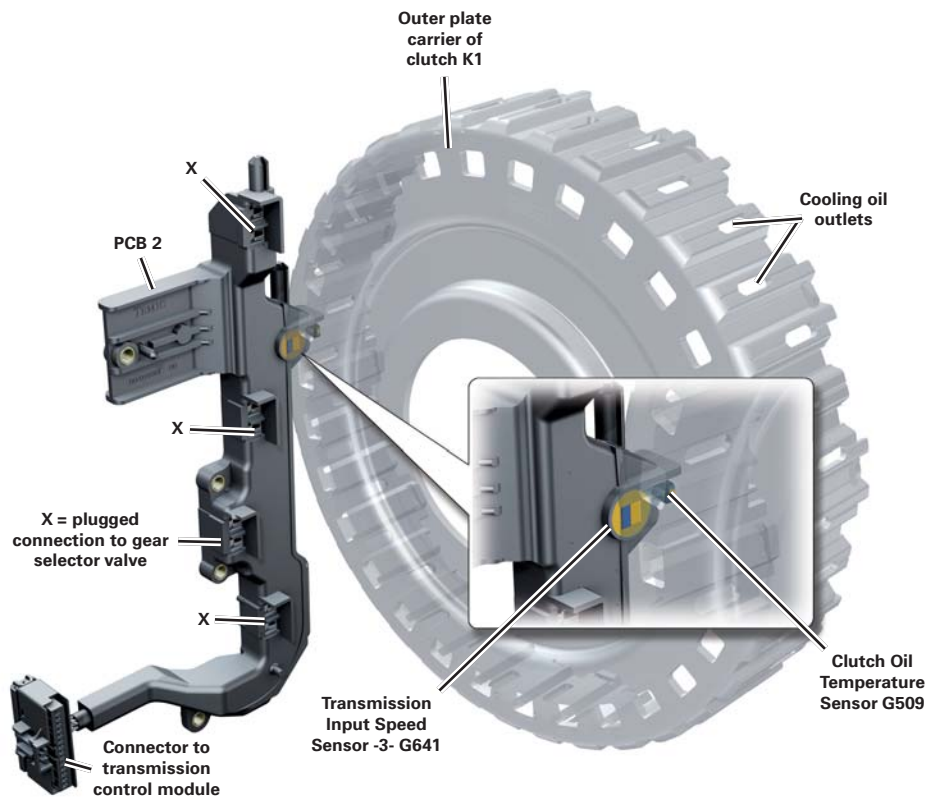

Sensors G641 and G509 are integral parts of PCB2. G641 is a Hall sensor. It measures the input speed of the dual clutch (engine speed after the dual-mass flywheel). The outer plate carrier of clutch K1 serves as an encoder disc.

The clutch input speed signal:

- Allows more precise clutch control
- Is used for adapting the clutches
- Is used for regulating micro-slip

G509 measures and monitors the temperature of the cooling oil emerging from the dual clutch. Clutch temperature can be derived from this information.

When a defined oil temperature is reached, safety precautions are taken to prevent a further rise in temperature.

Transmission Protection Functions

Control Module Temperature Monitoring

High temperatures have a negative impact on the useful life and performance of electronic components. Due to the integration of the transmission control module into the transmission housing (lubricated by ATF), it is very important to monitor the temperature of both the electronics and ATF.

When the temperature reaches approx. 275°F (135°C) (measured by one of the two temperature sensors in the transmission control module), the electronics must be protected against a further rise in temperature. When this threshold value is exceeded, the transmission control module initiates a reduction in engine torque to reduce heat input.

Up to a temperature of approx. 293°F (145 °C), engine torque can be reduced gradually until the engine is at idle. When the engine is at idle, the clutches are open and there is no power transmission from the engine to the drive wheels.

When the protective function is activated, an entry is made in the fault memory and the following text message is displayed in the instrument cluster: "You can continue driving to a limited extent."

Clutch Protection

If the clutch cooling oil temperature exceeds a value of approx. 320°F (160 °C), as determined by G509, the clutch is within a critical temperature range that can damage it. These temperatures occur, for example, when accelerating on extreme gradients, when towing a trailer, or when the vehicle is held stationary on an uphill slope using the accelerator and the clutch without engaging the brake.

As a safety precaution, engine torque is reduced when cooling oil temperature exceeds 320°F (160 °C.) If the cooling oil temperature continues to rise, engine torque is gradually reduced, sometimes to idle. When the engine is at idle, the clutches are open and there is no power transmission from the engine to the drive wheels.

When the protective function is initiated, an entry is made in the fault memory and the following text message is displayed in the instrument cluster: "You can continue driving to a limited extent."

As an additional safety precaution, the clutch temperature is determined using a computer model. If the computed temperature exceeds a pre-defined value, the above mentioned precautions are taken.

All you need to know about the ...

... transmission control module

In the B8 series, a new data and diagnostic log is used for the engine control modules, the TCM, and the airbag control module. The previous data blocks and numberings are no longer used. Individual measured data is now available and listed as full text in alphabetical order. This required measured data can then be specifically selected.

... clearing the fault memory

The fault memories of the engine and transmission control module are always cleared jointly. If the fault memory of the transmission control module is cleared, then the fault memory in the engine control module will be cleared as well. The converse applies if the memory of the engine control module is cleared.

... towing

If a vehicle with S tronic needs towing, the conventional restrictions of automatic transmissions apply:

- Selector lever in position “N”
- A maximum towing speed of 30 mph (50 km/h) must not be exceeded
- A maximum towing distance of 30 mi (50 km) must not be exceeded

Explanation:

When the engine is at standstill, the oil pump is not driven and certain parts of the transmission are no longer lubricated. Exceeding a speed of 30 mph (50 km/h) results in unacceptably high rotational speeds within the gearbox and dual clutch, because one gear is always engaged in both sub-gearboxes.

If these towing cautions are not observed, serious transmission damage can occur.

“Limp Home” Programs

In the event of a malfunction, serious damage can be prevented and mobility preserved by means of “limp home” programs initiated by the transmission control module. In addition, there are also protective functions, which protect certain components against overload.

In the event of certain pre-defined system malfunctions, the transmission control module shuts down the sub-gearbox in question and activates the relevant “limp home” program (driving with intact sub-gearbox).

1. Driving with sub-gearbox 1, sub-gearbox 2 shut down:

- Only gears 1, 3, 5, and 7* can be engaged (with interruption in tractive power)
- Backing up (reversing) is not possible

2. Driving with sub-gearbox 2, sub-gearbox 1 shut down:

Only gears 2, 4, 6, and R* can be engaged (with interruption in tractive power).

3. Complete gearbox shutdown:

In the case of serious faults — for example, a faulty powertrain CAN, no identification by the immobilizer, or recognition of an incorrect ratio in the gear steps or in the final drive — the gearbox is completely shut down.

* The nature of the fault dictates which gears are still available. To be sure that components do not overspeed, certain gears are disabled depending on fault type. After ensuring that no gear is engaged in the deactivated gearbox, all gears of the intact sub-gearbox are shifted without any further restrictions.

Displays/Warnings

The OB5 transmission features new information and warning technology in the instrument cluster, which will alert the driver to a system malfunction or the initiation of a protective function.

The following warnings are displayed:

Display 1 appears when faults the driver may not notice are recognized by the transmission control module, which then activates a suitable substitute signal.

These faults result in no, or only negligible, loss of performance. The purpose of the warning is to prompt the driver to take the vehicle to an Audi dealer at the next opportunity.

Display 1



Display 2 appears when gearbox protection functions and faults result in a loss of performance.

This can have the following effects:

- "Limp home" program: "Driving with sub-gearbox 2" is active. For example, gearshifts have interruptions in tractive power (even-numbered gears only)
- Gearbox protective function is active, but engine power is reduced because the engine torque reduction function is also active
- No power transmission to the driving wheels after stopping
- The engine can no longer be started

Display 2



Display 3 appears when the "limp home" program, "Driving with sub-gearbox 1," is active because reverse gear cannot be selected at the same time.

Text messages disappear after five seconds, and are displayed again for five seconds at "ignition ON." Yellow warning symbols are permanently displayed.

Display 3



Sport Differential

Traditional quattro Drive

Since 1980, quattro has been synonymous with outstanding driving dynamics. In its basic form, the torque-sensing center differential delivers 40% of the tractive force from the engine to the front axle and 60% to the rear axle.

This degree of rearward bias is now standard on all newer Audi models because it ensures optimum performance. The torque-sensing differential redistributes engine output without delay if road surface conditions change.

The quattro system technology also has distinct advantages in terms of lateral dynamics. By distributing traction among all four wheels, each wheel has greater potential to resist lateral forces, and tire grip is optimized.

The action of the electronic differential lock (EDL) and typical Audi settings adopted for the ESP also add to a high level of stability.



990193_001

quattro Drive with Sport Differential

The quattro system with electronically controlled sport differential distributes input torque variably between the two rear wheels, with nearly all tractive force directed to just one wheel, if necessary.

Torque input also ensures a neutral road behavior. The sport differential is active not only under load, but also on overrun. Its torque distributing action enhances car agility when the clutch is disengaged.

Depending on steering angle, lateral acceleration, yaw angle, road speed, and other signals, the control module calculates the most suitable distribution of torque to the rear wheels for every driving situation.

When the steering wheel is turned, for example, or when the car is accelerated in a corner, power is redirected in a controlled manner to the outer rear wheel. This has the effect of "forcing" the car into the corner so that the angle of the front wheels is followed accurately.

The difference in tractive force between the left and right wheels also exerts a steering effect, so that the usual corrections by the driver at the steering wheel are no longer needed. Understeer, the tendency for the car to run wide at the front when cornering, is virtually eliminated.

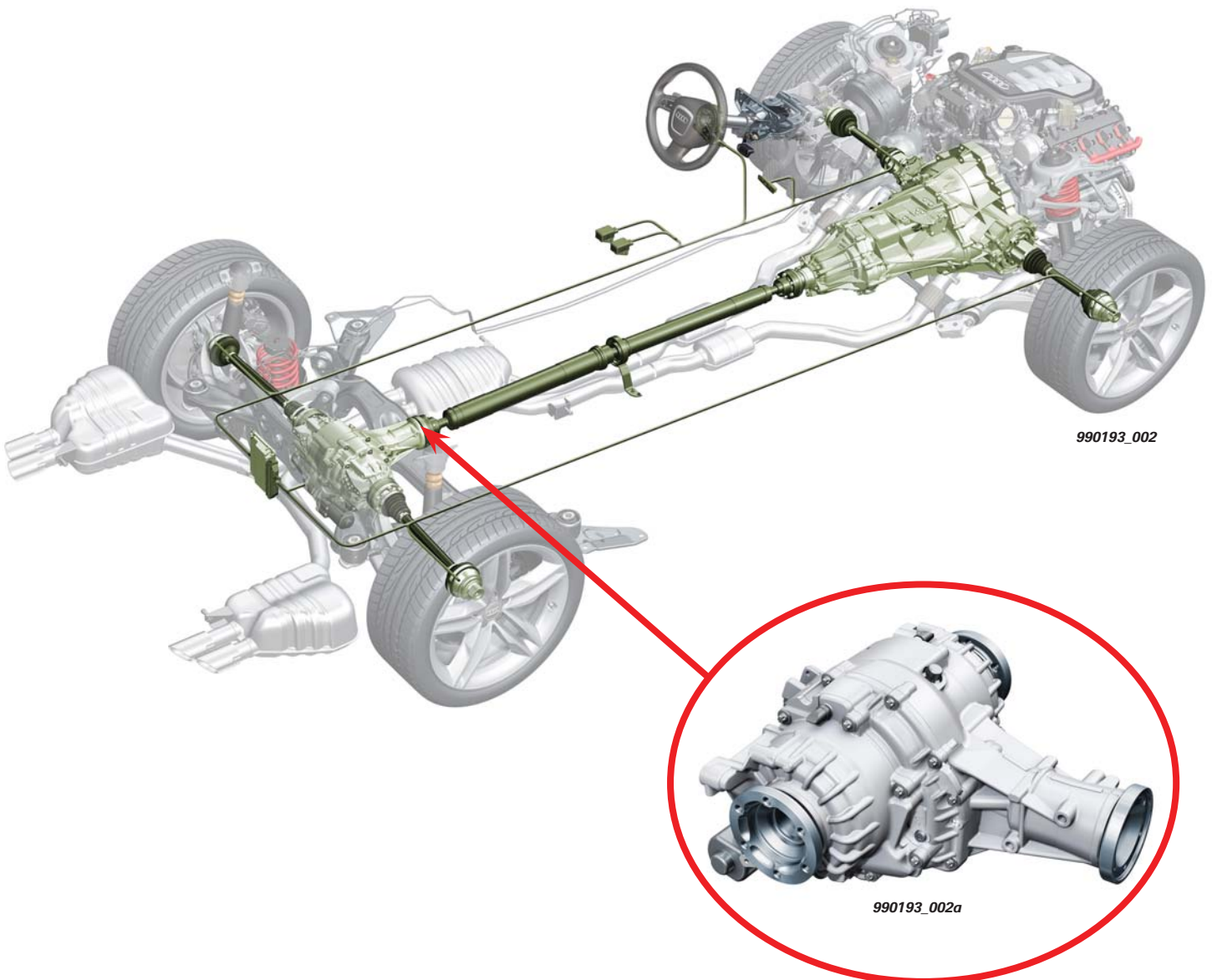

Sport Differential

Traditional quattro Drive

In the illustration below, a car adheres to successive bends when driven rapidly along a typical country road, similar to the precise track formed by skis in snow. The sport differential redistributes the power input continually and quickly and counteracts any tendency for the car to understeer or oversteer before either of these effects can build up. For the driver, this means reduced effort at the steering wheel and higher maximum lateral acceleration.

When approaching the car's handling limits, the sport differential acts like ESP, but with the principle reversed. Corrective movements are not initiated solely by altering the engine settings or applying the brakes, but also by controlled redistribution of tractive force through the sport differential. The car's forward progress becomes distinctly smoother and free-flowing because its actual road dynamics and those sensed subjectively by the driver are enhanced since ESP comes into action much less frequently.

Since its reaction time is extremely short – less than 100 milliseconds – the sport differential takes effect even more rapidly than ESP. Furthermore, ESP can only react to a discrepancy between the car's steering angle and its actual body rotation, whereas the sport differential influences the car's dynamic behavior before any such discrepancies occur. During sport differential action, ESP is not active.

Active torque distribution is based on an entirely new design principle for the rear axle differential. The unit can also divert torque to the outer wheel on the axle, which then rotates faster than the inner wheel when cornering. The rear axle differential has speed modulation units with multi-plate clutches mounted at the left and right sides. The clutches are activated by electro-hydraulic actuators based on input from sensors and other control modules.

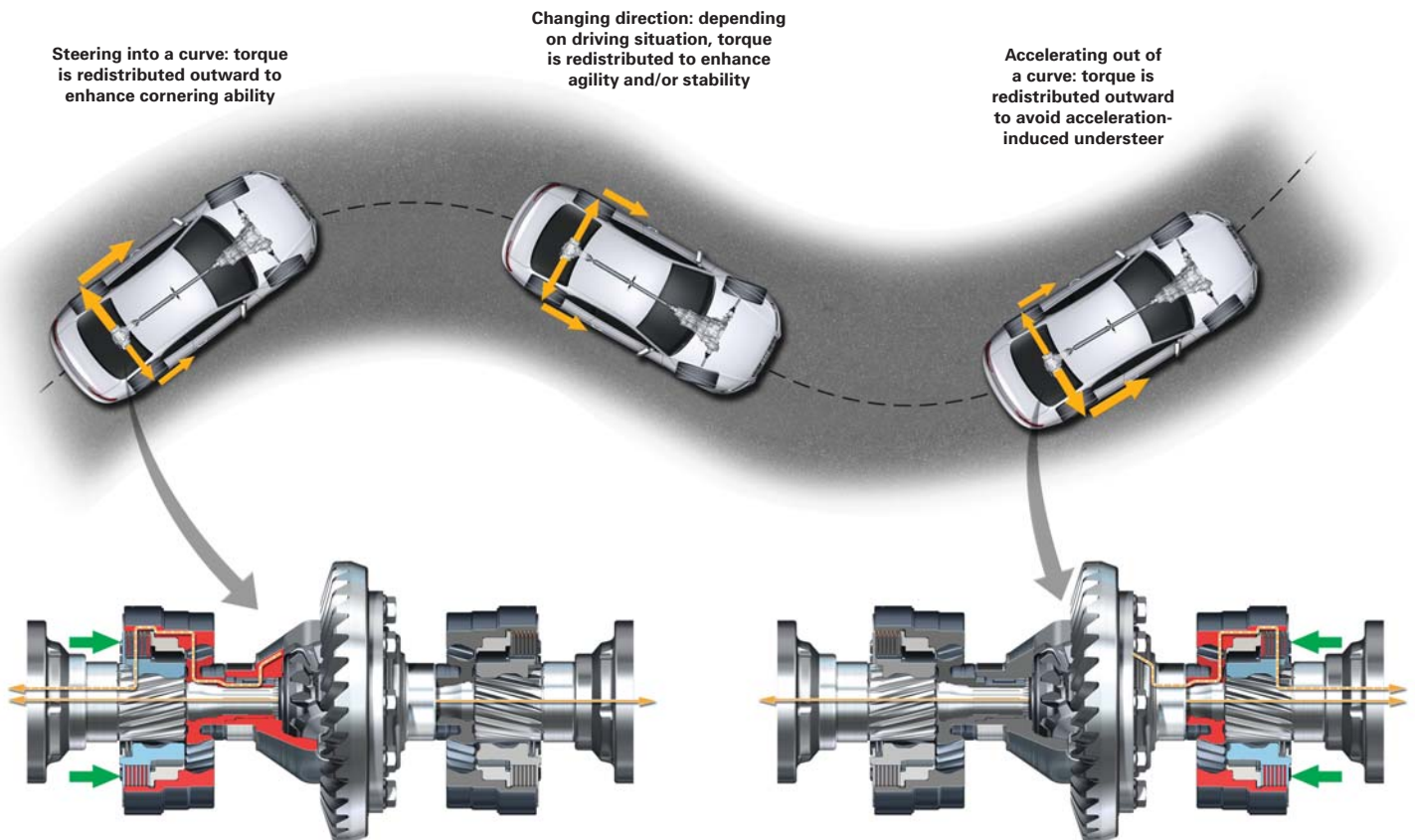

990193_003

Audi Drive Select with Sport Differential

The quattro driveline with sport differential is also part of Audi drive select, which integrates key components that affect each driving experience. These components include the engine, transmission, steering, shock absorbers, and sport differential. Drivers can adjust the characteristics of these systems at any time to suit their personal preferences.

Buttons on the center console enable drivers to vary the operation of Audi drive select in three stages ranging from comfortable to sport mode, or to create a profile that suits their personal preferences.

The engine's throttle response characteristic can be determined first, followed by that of the servotronic speed dependent power steering and, if the car has automatic transmission, its shift points.

The functions of the sport differential can also be varied to suit the driver's wishes. In "comfort" mode, driving safety and vehicle stability have absolute priority, with optimal damping of load reversals. In "auto" mode, a balance is achieved between all of the functions. The "dynamic" mode ensures optimum vehicle agility during load reversals.



Sport Differential

Component Overview

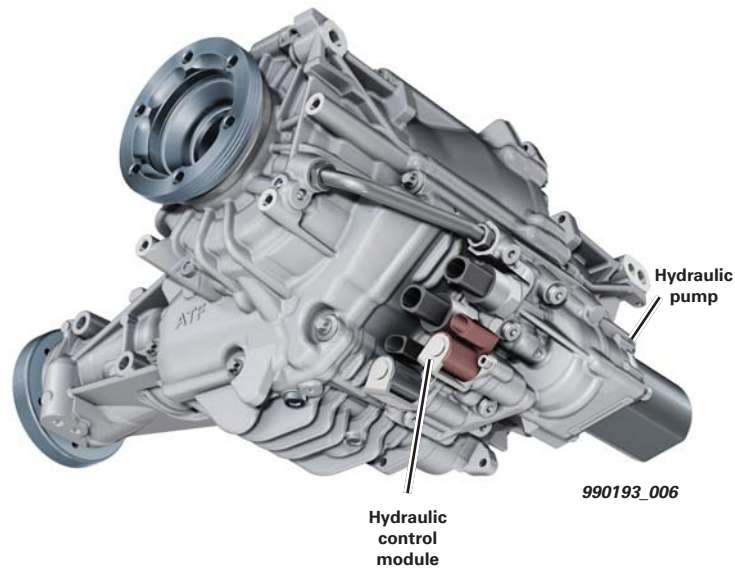
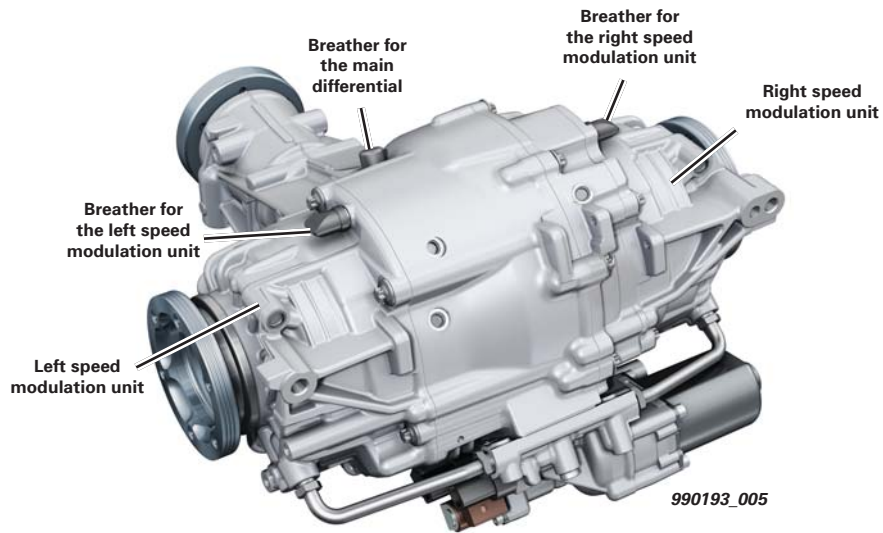

Specifications

Service Designations:	Final drive 0BF, internal: HL601
Development:	Magna powertrain (Graz, Austria) — Audi AG
Manufacturer:	Magna powertrain
Torque Capacity:	Up to approx. 480 lb ft (650 Nm) engine torque
Speed Modulation Unit Ratio:	i_{tot} 1.095
Weight:	Approx. 95.9 lb (43.5 kg) including oil

Sport Differential

The sport differential has a conventional pinion shaft and ring gear. Attached at both sides of the differential are speed modulation units. These units are made up of two sun gears and two ring gears and are sometimes referred to as speed modulation gearboxes or super-position gearboxes. They provide a step-up (or step-down) transmission ratio for each axle depending on the driving situation.

The engagement of the speed modulation units is done electro-hydraulically. Pressure is developed by an electric motor-driven hydraulic pump and directed to the multi-plate clutches by a hydraulic control module. Clutch actuation is determined by All Wheel Drive Control Module J492.

This ability to change the ratio (dependent on driving situation) is also referred to as "torque vectoring."

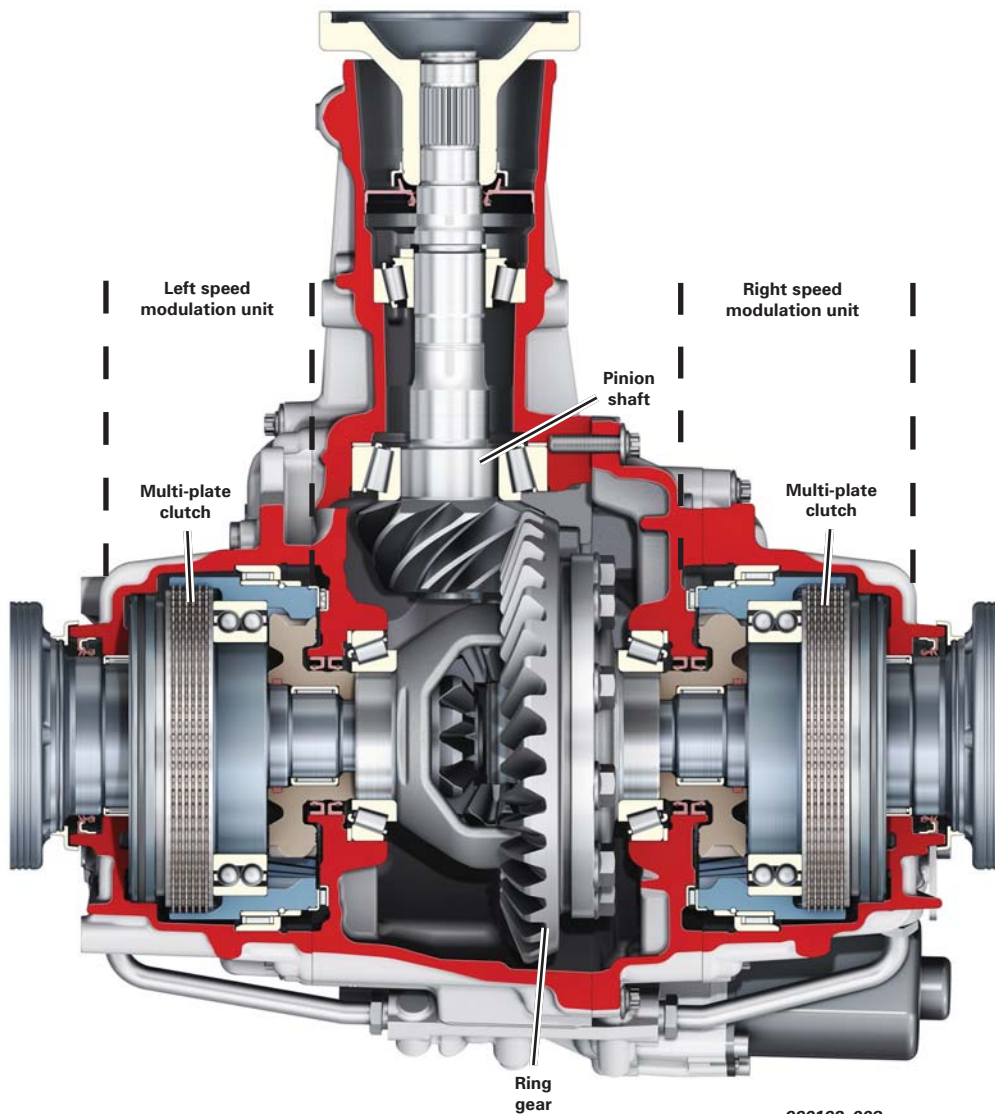

Sport Differential

Speed Modulation Gearbox Component Overview

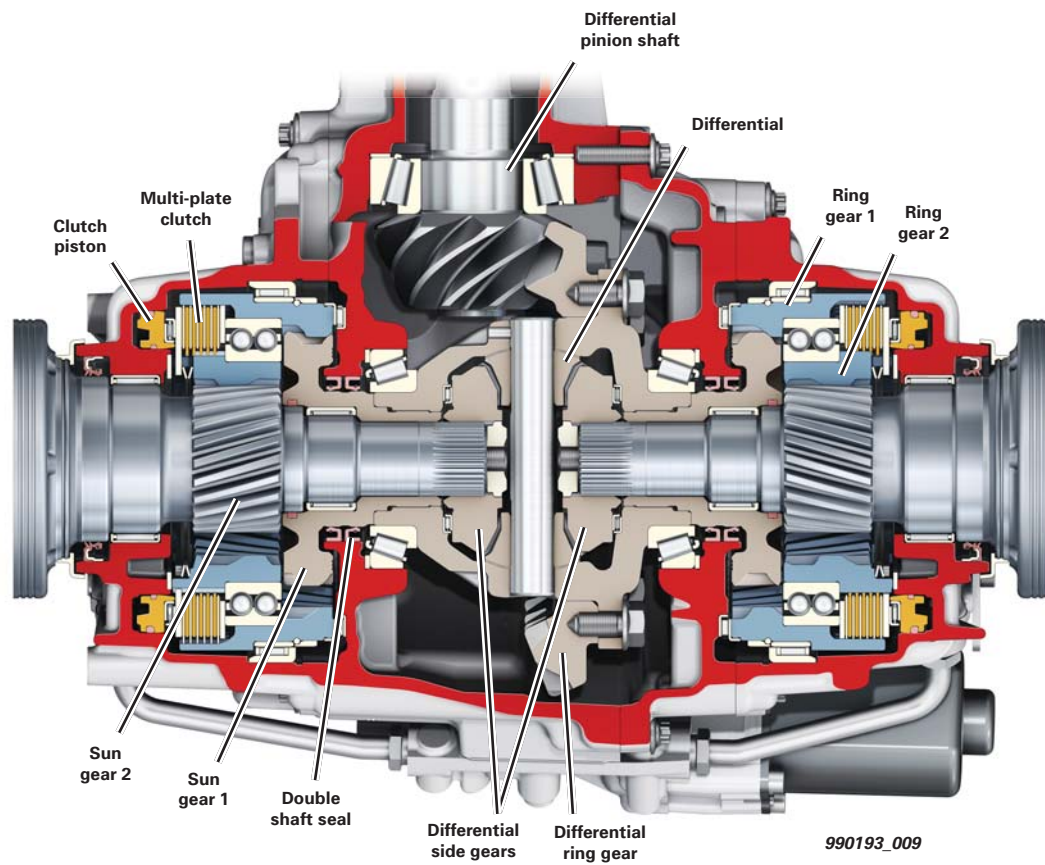

Sport Differential

Sun gear 1 is integral with the differential housing and, therefore, turns at the same speed. Sun gear 1 is internally meshed with ring gear 1 which rotates at a ratio of 0.868.

Sun gear 2 is integral with the stub axle. When a multi-plate clutch is engaged, ring gear 2 is joined to ring gear 1. Ring gear 2 then drives sun gear 2 which in turn drives the stub axle. Combining the gear ratios of both sun gears and ring gears provides the final output ratio to the stub axle.

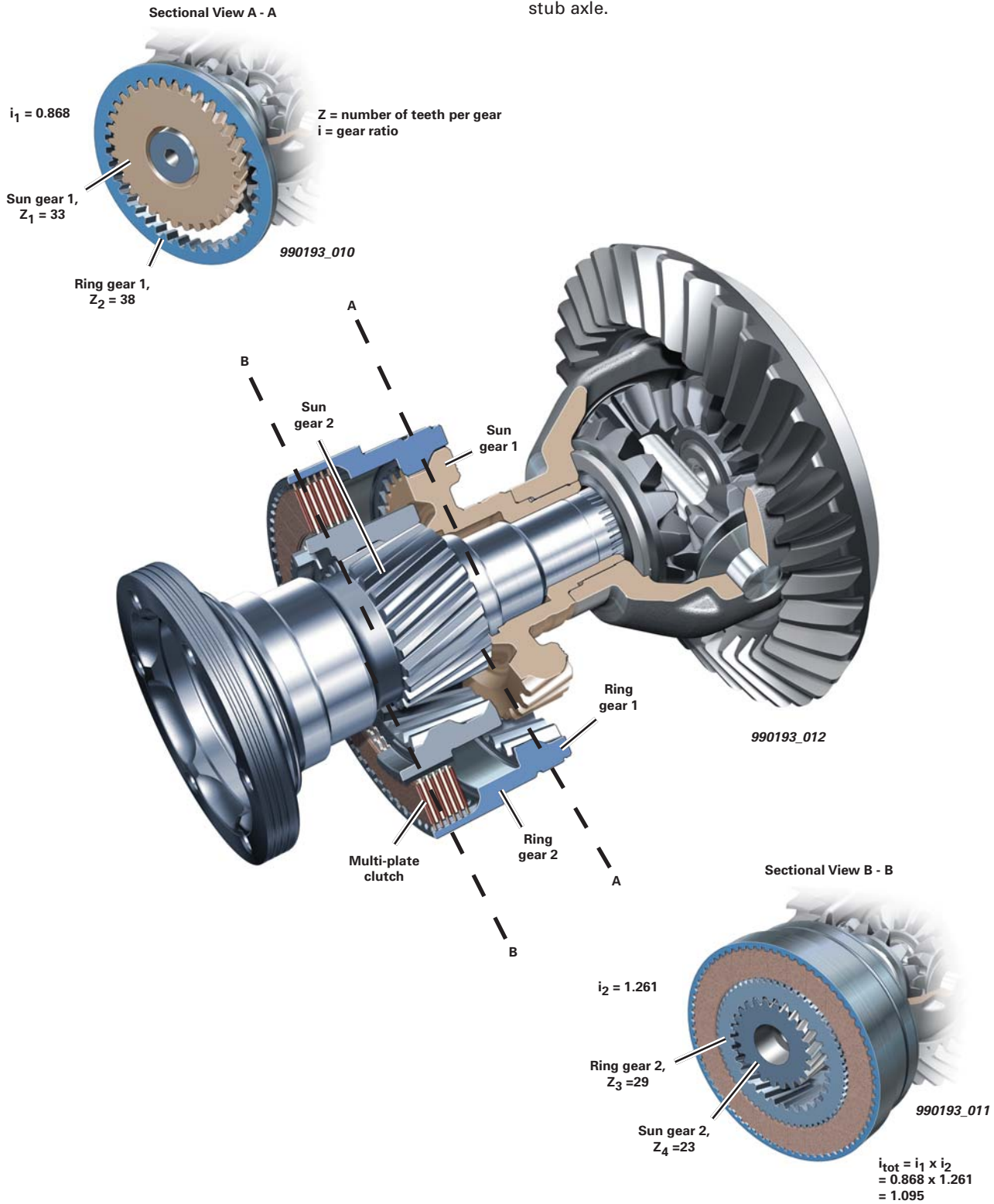

Sport Differential

Power Flow Without Intervention

The sport differential functions as a normal open differential when the multi-plate clutches of the speed modulation boxes are not engaged.

Torque is transmitted from the pinion shaft to the ring gear. The differential transfers the torque to the axles via the side gears.

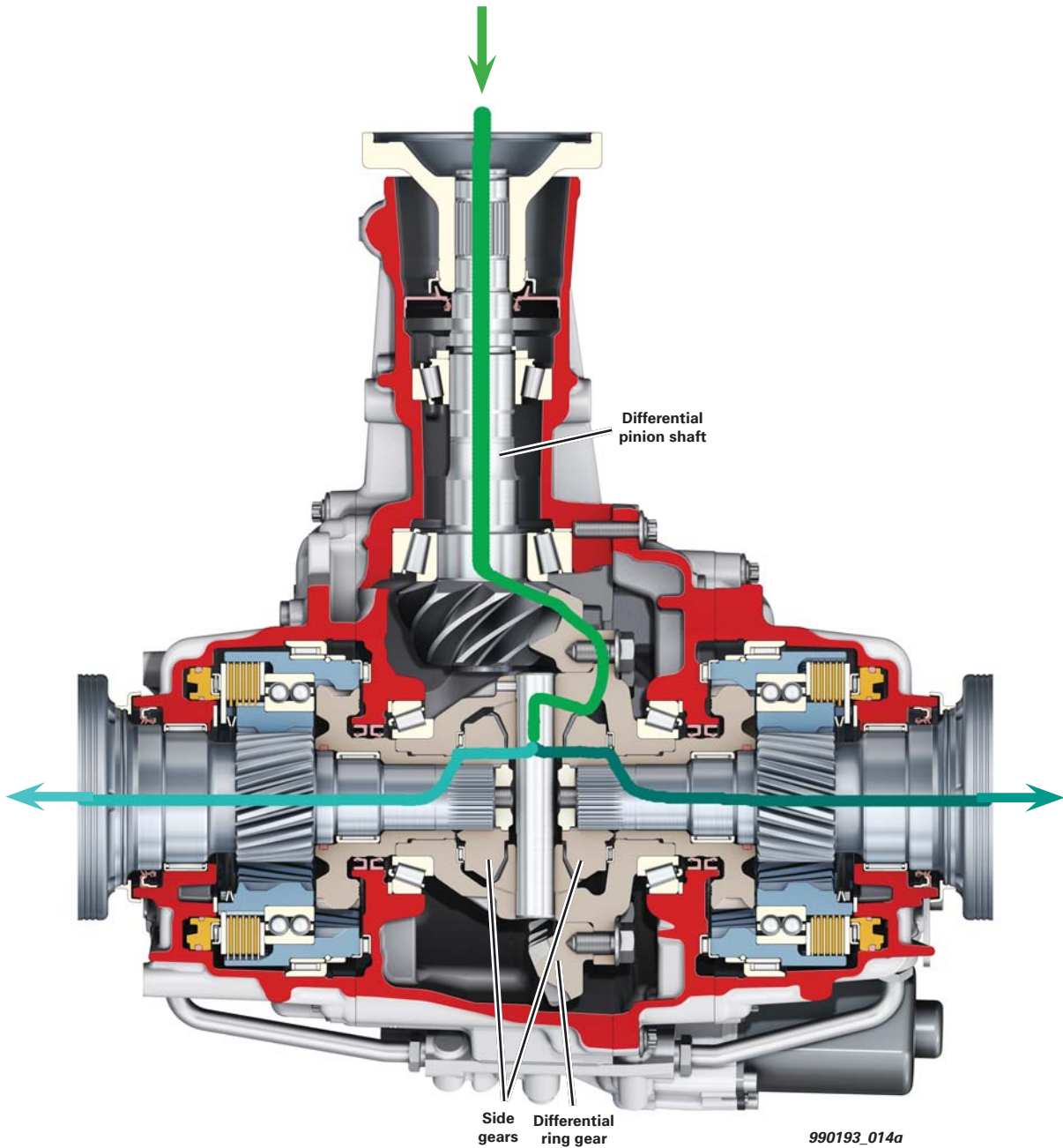

990193_014a

Power Flow With Intervention

The differential ring gear drives sun gear 1 which in turn drives ring gear 1. With clutch activation, ring gear 1 and ring gear 2 are joined together. Ring gear 2 drives sun gear 2 which drives the stub axle.

Only one speed modulation gearbox can be engaged at a time. When activated, the clutches do not fully engage, as there is always a defined amount of slip between the plates. This slip is monitored by All Wheel Drive Control Module J492 and has important service implications.

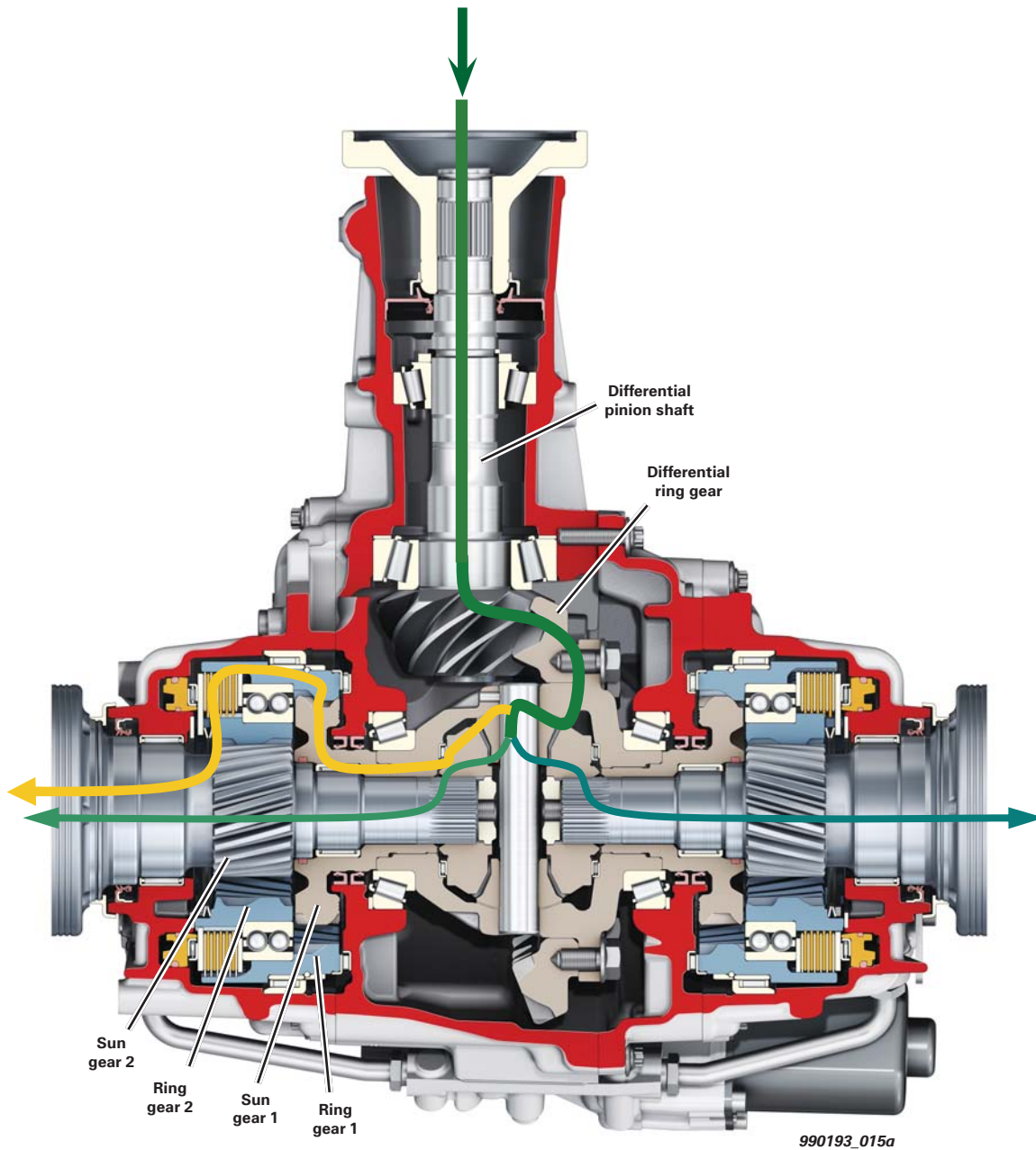

Sport Differential

Oil Circuits

The sport differential has two oil circuits and three distinct oil chambers.

The differential pinion and ring gear (conventional differential components) have a separate oil chamber filled with hypoid oil.

Two speed modulation gearboxes each have their own oil chamber and are interconnected by an oil passage. This forms a common oil circuit, which is filled with a special ATF. Both fluids are lifetime fills.

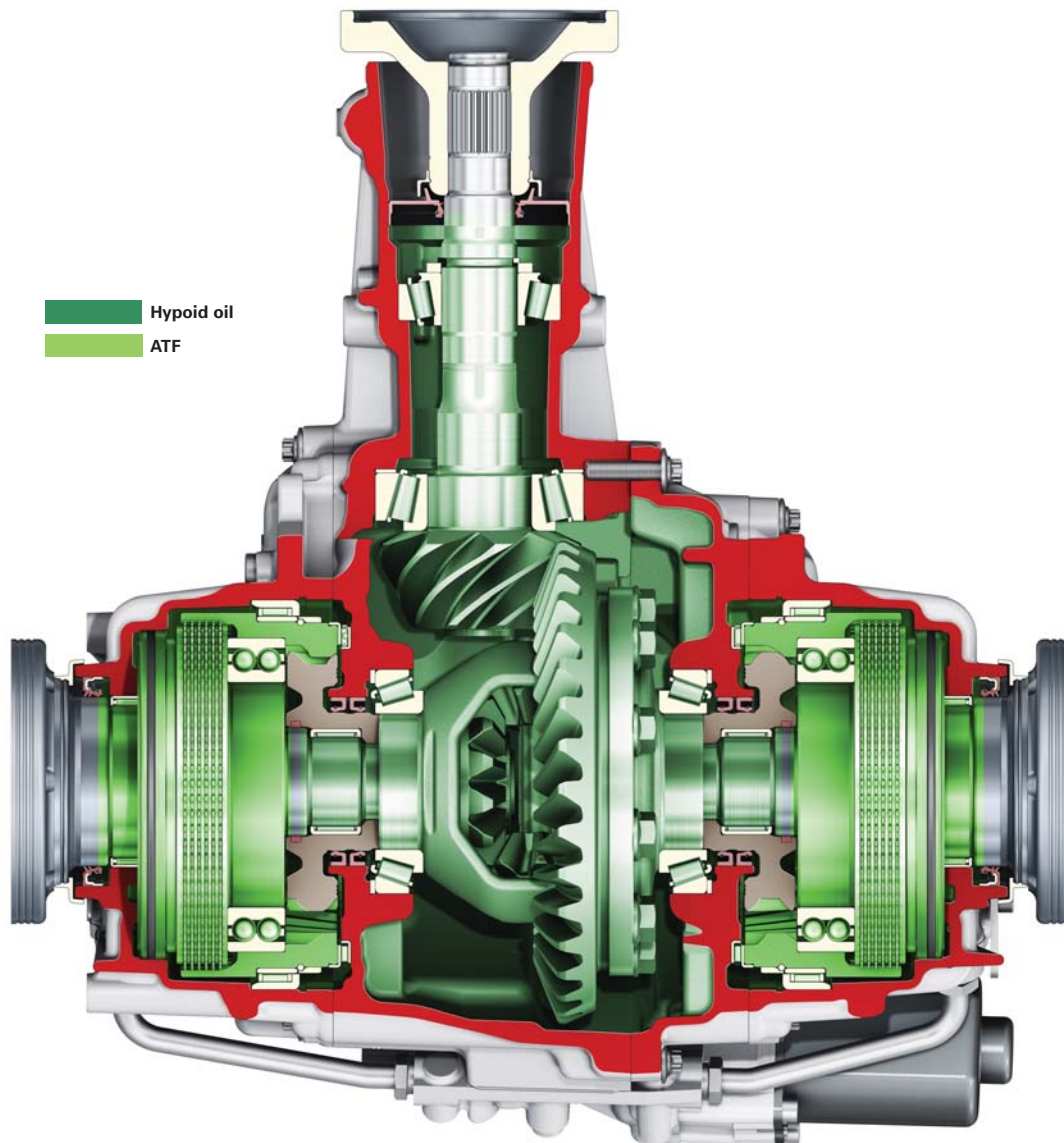

990193_016

Sport Differential

A ball valve integrated in the oil circuit prevents the ATF oil circuits from overflowing to one side during transverse acceleration.

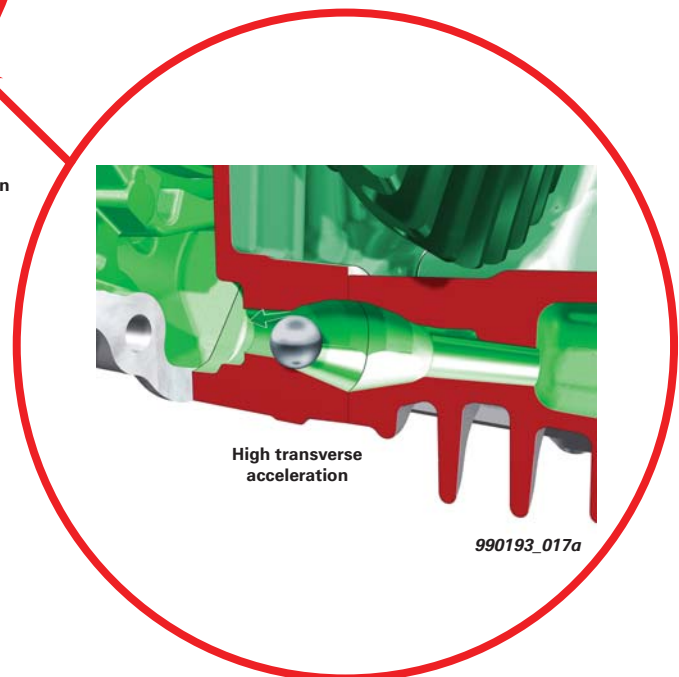
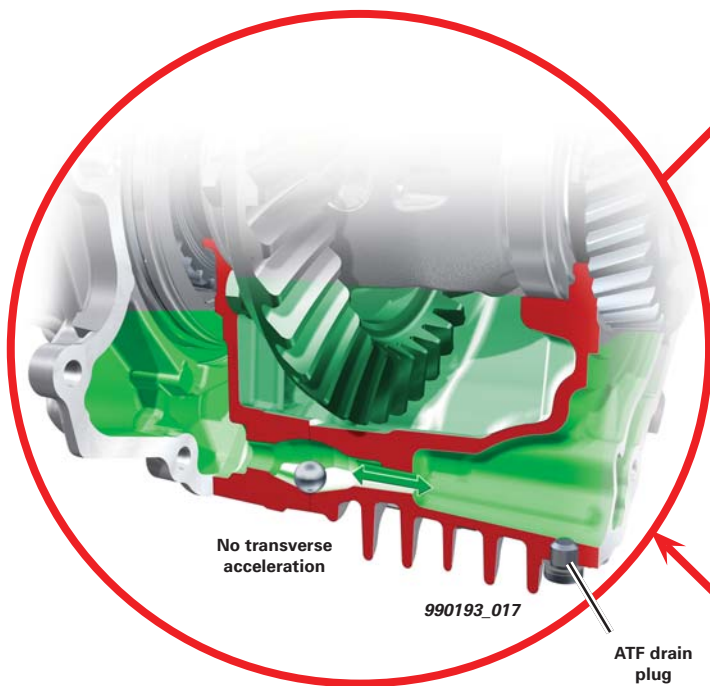
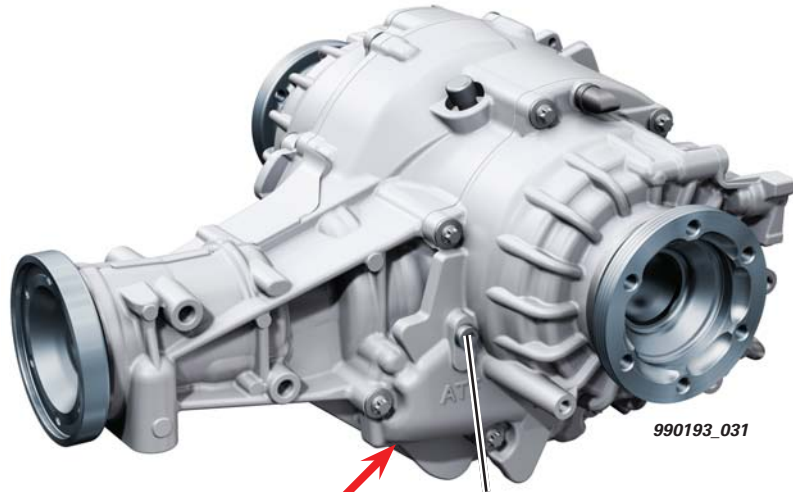

Sport Differential

Oil Circuit Separation

A double shaft seal and a special oil seal (rectangular ring) on each side ensures that the hypoid oil and ATF circuits are safely separated from each other.

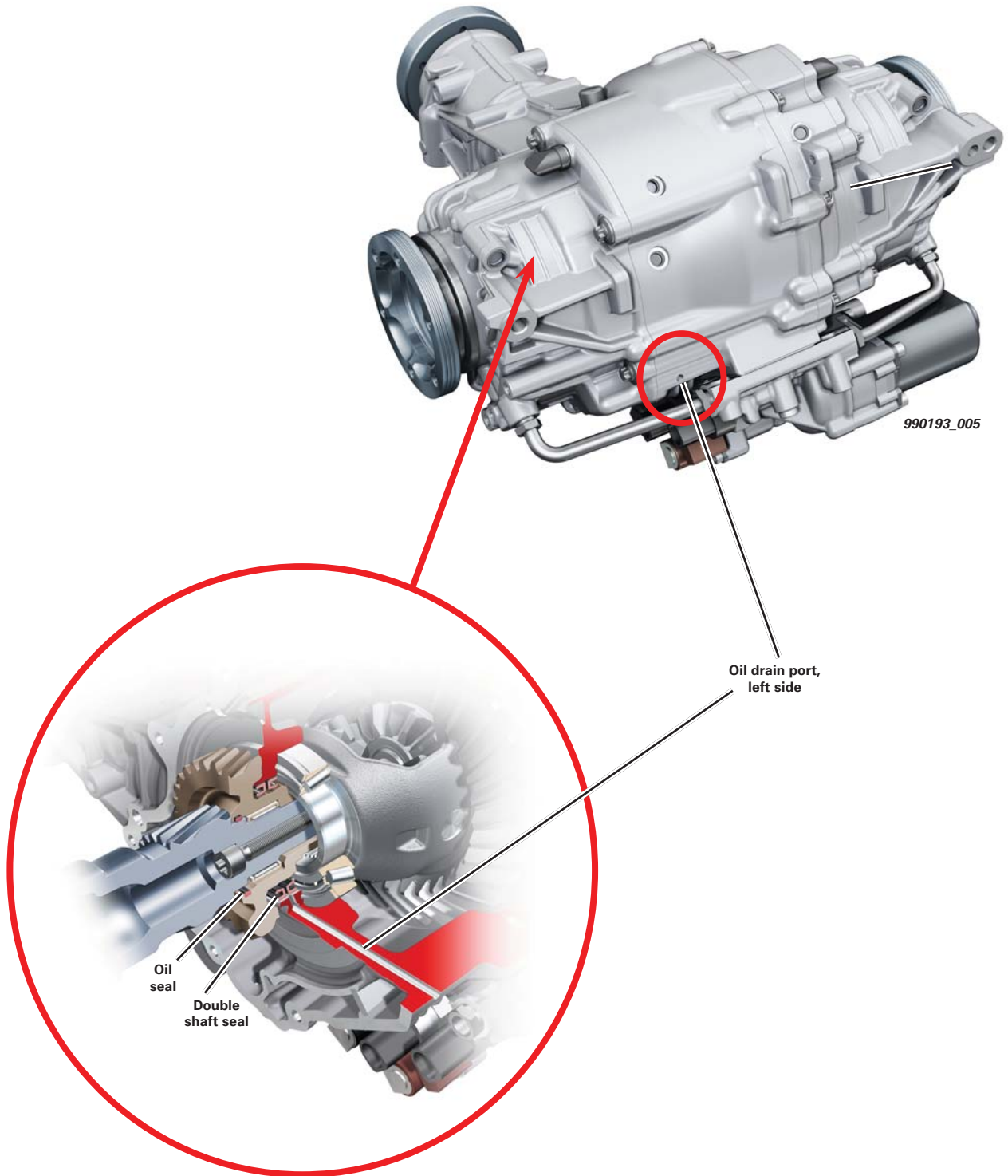

Sport Differential

Oil drain ports prevent the mixing of ATF and gear oil if a seal should fail. If a failure occurs, oil is vented to the outside of the axle housing via the drain port.

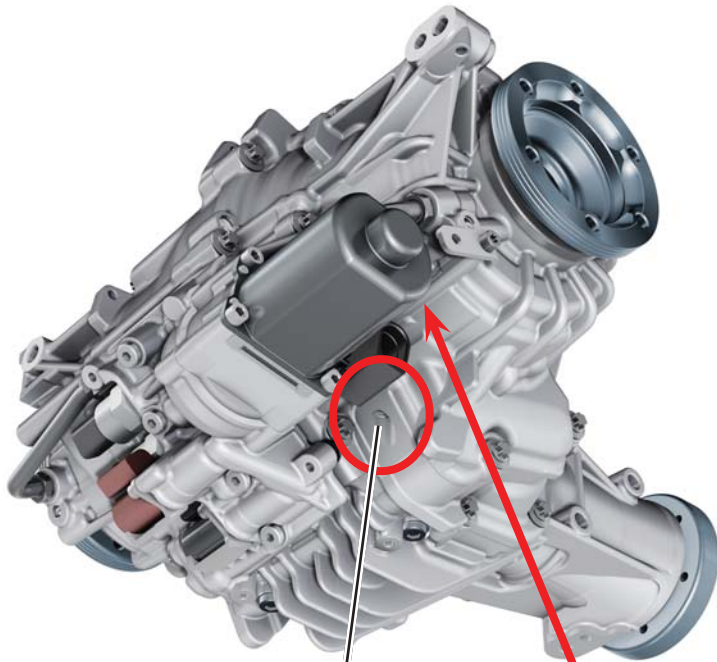

990193_019

Oil drain port,
right side

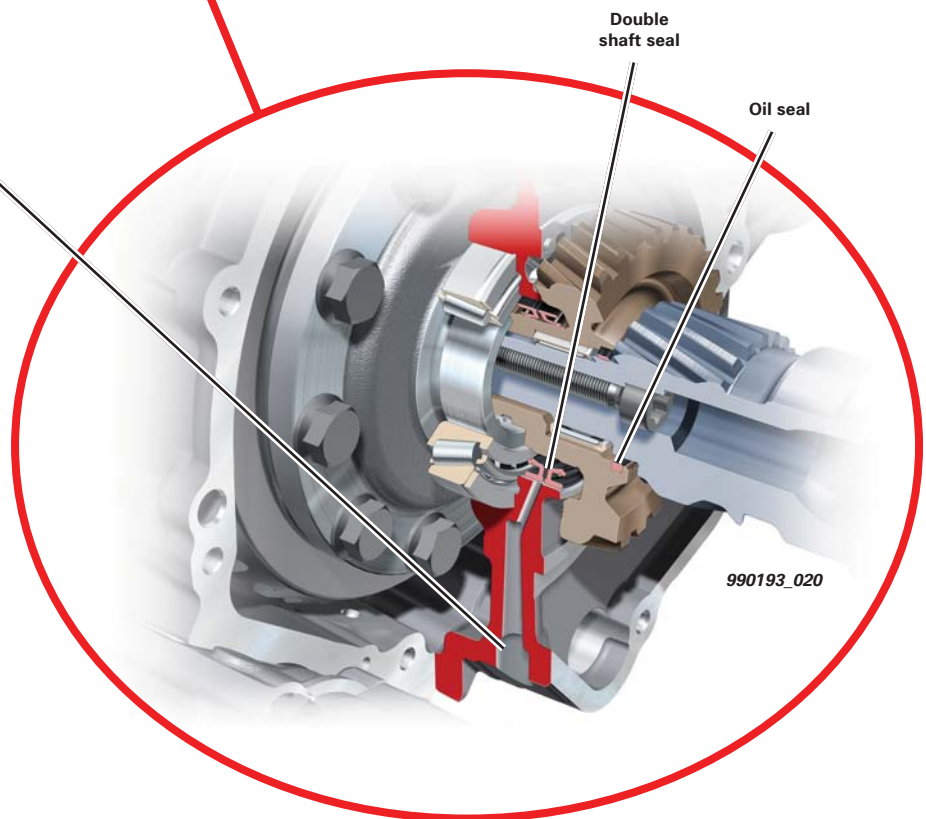

Double
shaft seal

Oil seal

990193_020

Sport Differential

Oil Inspection and Drain Plugs

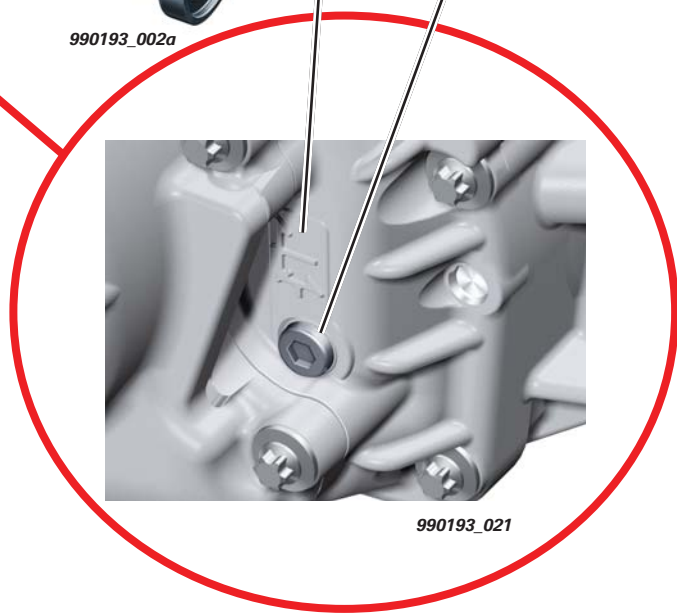
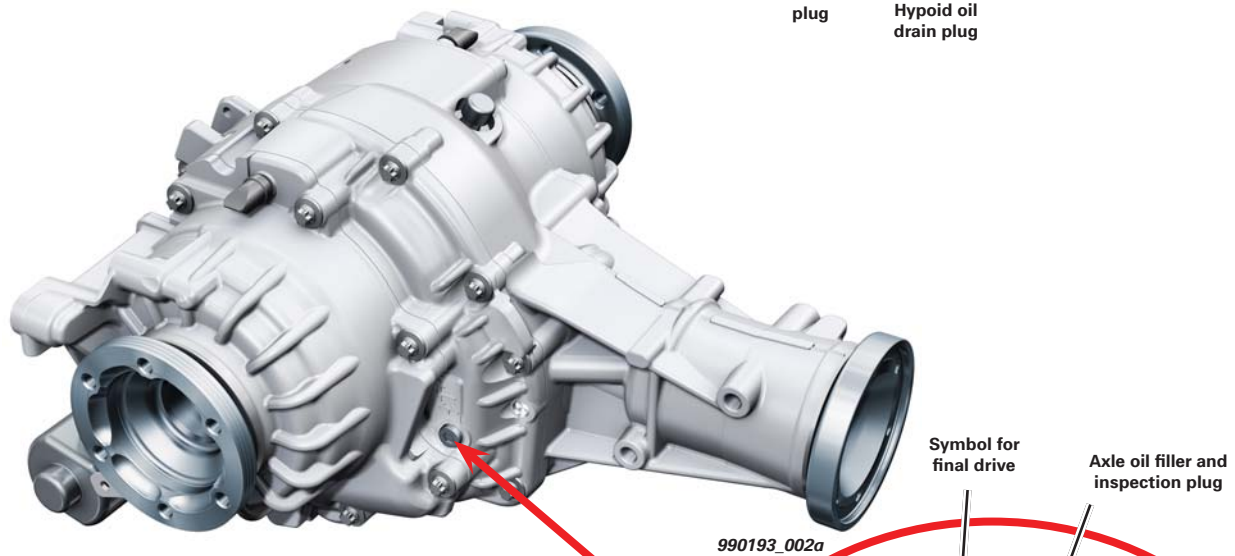
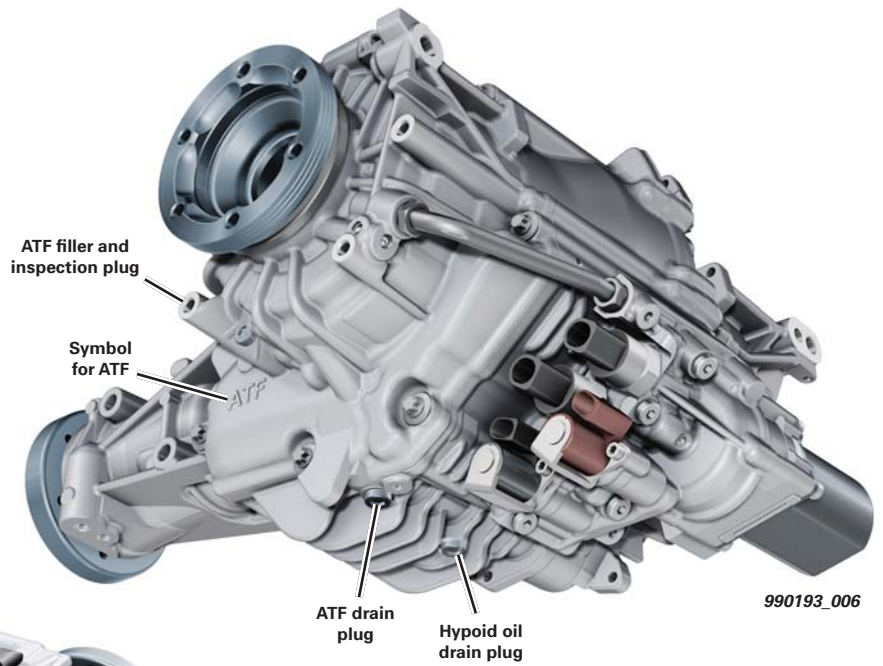

Hydraulic Control

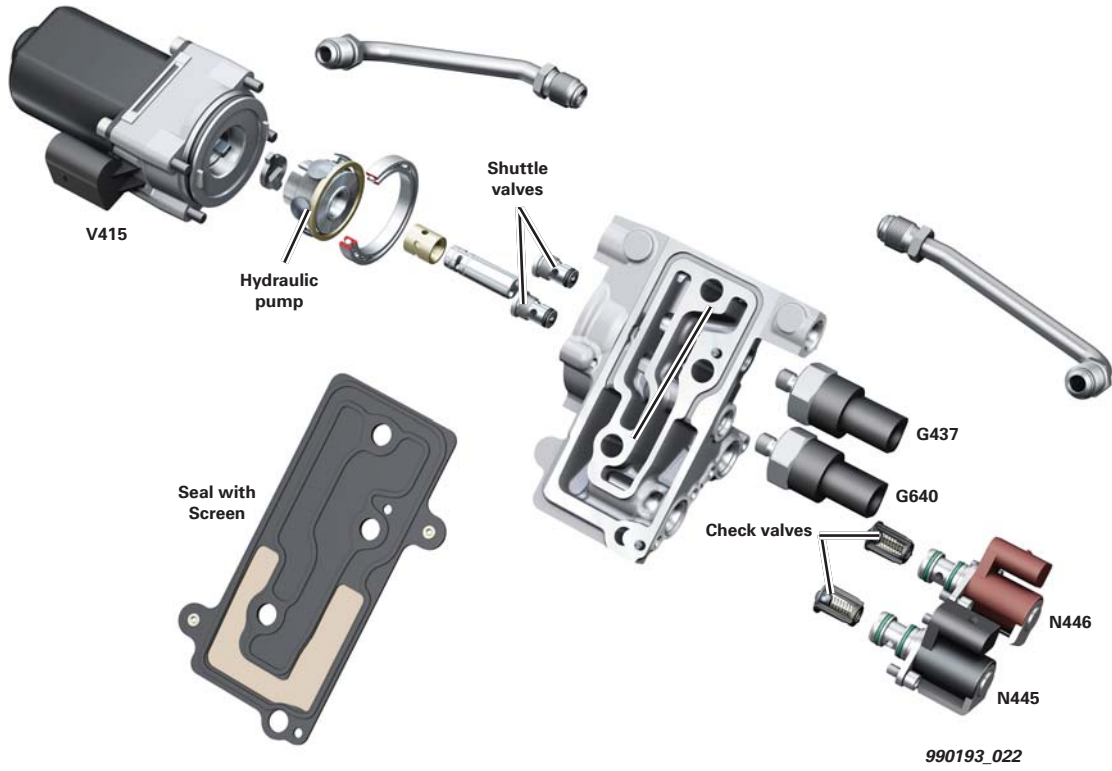
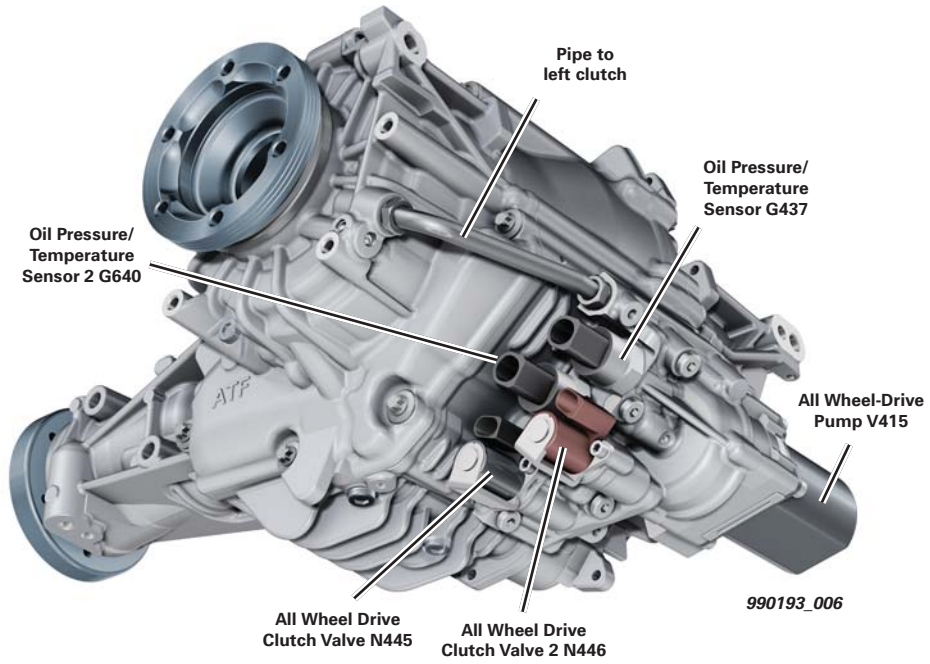

Sport Differential

Basic Configuration

Pressure for hydraulic operation is supplied by a pump driven by All Wheel Drive Pump V415. The pump operates in both directions dependent upon which clutch is to be activated.

The pressure limiting valves are designed to limit the extent of coupling force applied to the clutches to approx. 885 lb ft (1200 Nm). The shuttle valves move to prevent hydraulic pressure from being applied to both clutches at the same time.

Both the oil pressure and temperature sensors measure the same hydraulic pressure. However, they measure the pressure opposite from each other during clutch application. One will display a rising pressure while the other displays a falling pressure. This is done as a diagnostic function and plausibility check by All Wheel Drive Control Module J492.

All Wheel Drive Clutch Valve N445 and All Wheel Drive Clutch Valve 2 N446 are open until current is supplied.

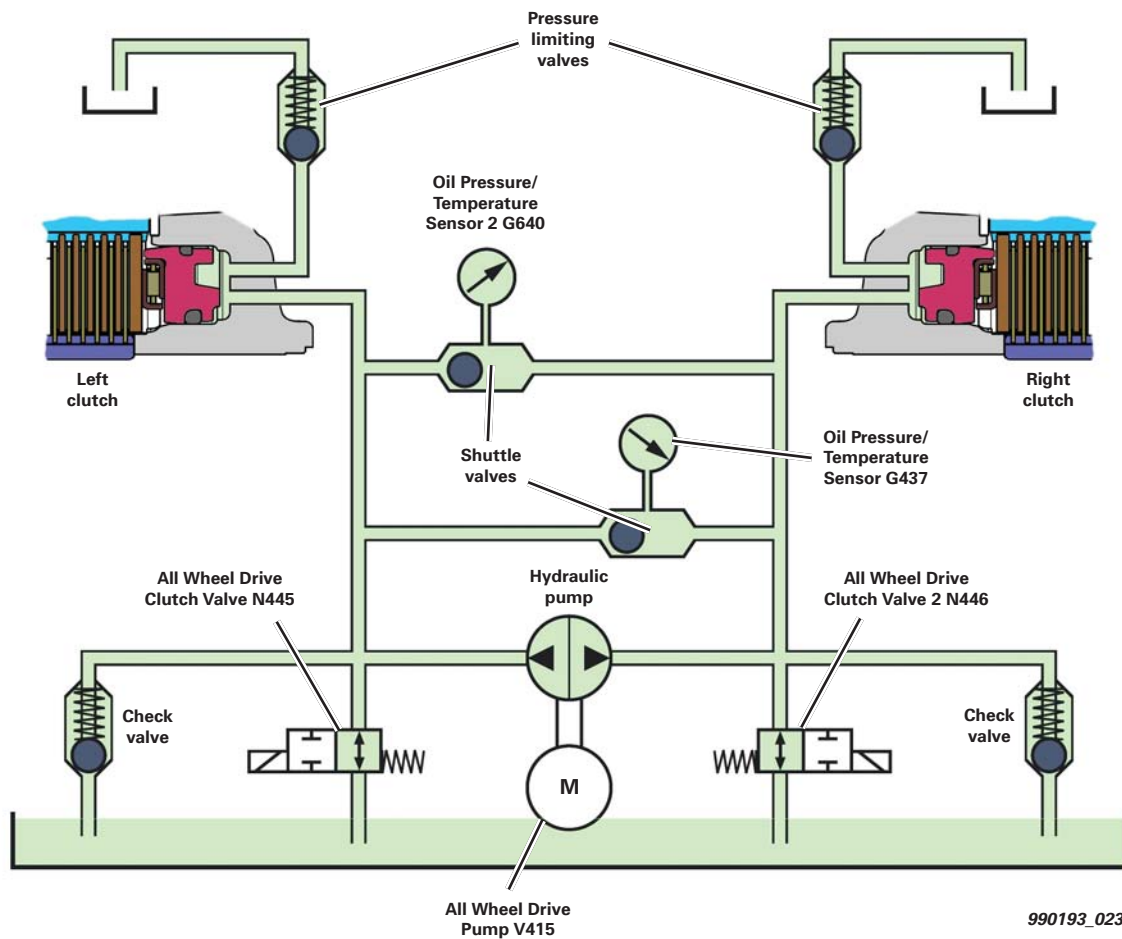

Activation of Right Clutch

The right clutch of the sport differential is activated, for example, when the vehicle is taking a curve to the left.

All Wheel Drive Pump V415 drives the hydraulic pump which suctions ATF from the sump through one check valve and All Wheel Drive Clutch Valve N445. Current is applied to close All Wheel Drive Clutch Valve N446 2 and pressure rises in the system.

The shuttle valves move to block oil pressure from being applied to the left clutch. Oil Pressure/Temperature Sensor G437 measures the pressure and displays it as a rising pressure. Oil Pressure/Temperature Sensor 2 G640 measures the same pressure but displays it as a declining pressure.

The hydraulic pressure developed applies the right clutch via its actuating piston.

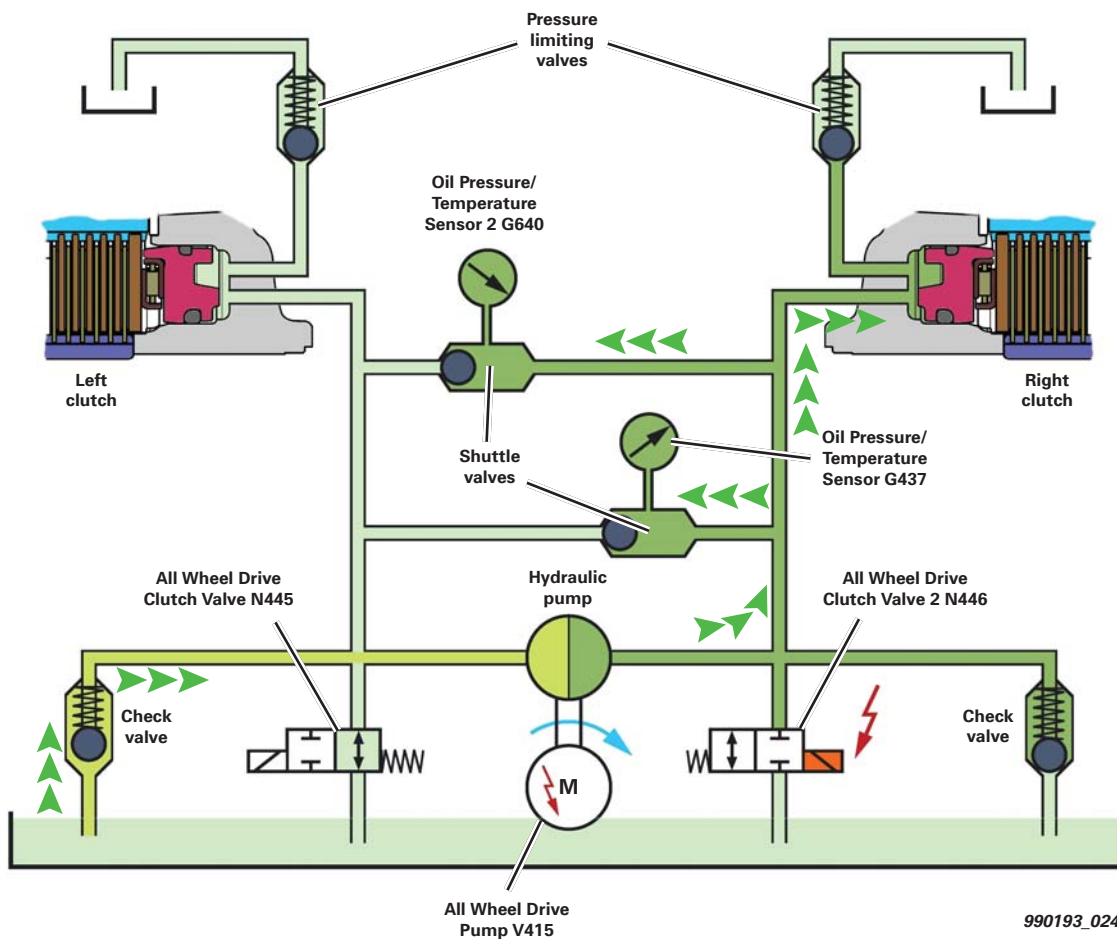

Sport Differential

Activation of Left Clutch

The left clutch of the sport differential is activated, for example, when the vehicle is taking a curve to the right.

All Wheel Drive Pump V415 drives the hydraulic pump in the opposite direction as before. This suction ATF from the sump through one check valve and All Wheel Drive Clutch Valve 2 N446. Current is applied to close All Wheel Drive Clutch Valve N445 and pressure rises in the system.

The shuttle valves move to block oil pressure from being applied to the right clutch. Oil Pressure/Temperature Sensor G437 measures the pressure and displays it as a declining pressure. Oil Pressure/Temperature Sensor 2 G640 measures the same pressure but displays it as a rising pressure.

The hydraulic pressure developed applies the left clutch through its actuating piston.

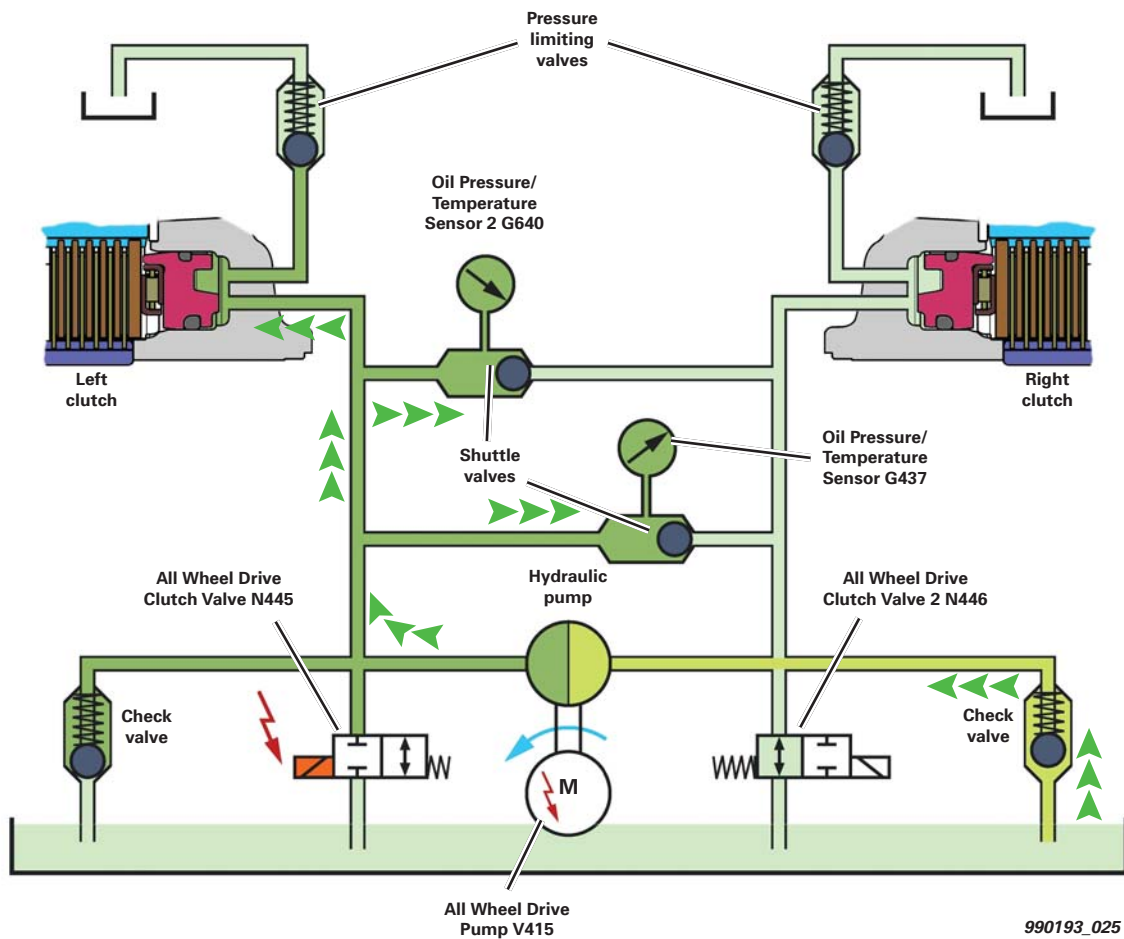

Pressure Reduction 1

Reduction of hydraulic pressure is done in two stages. In this example, the pressure is being reduced from the left clutch.

In the first stage, hydraulic pressure is released via All Wheel Drive Clutch Valve 2 N446. Current is still being applied to All Wheel Drive Clutch Valve N445.

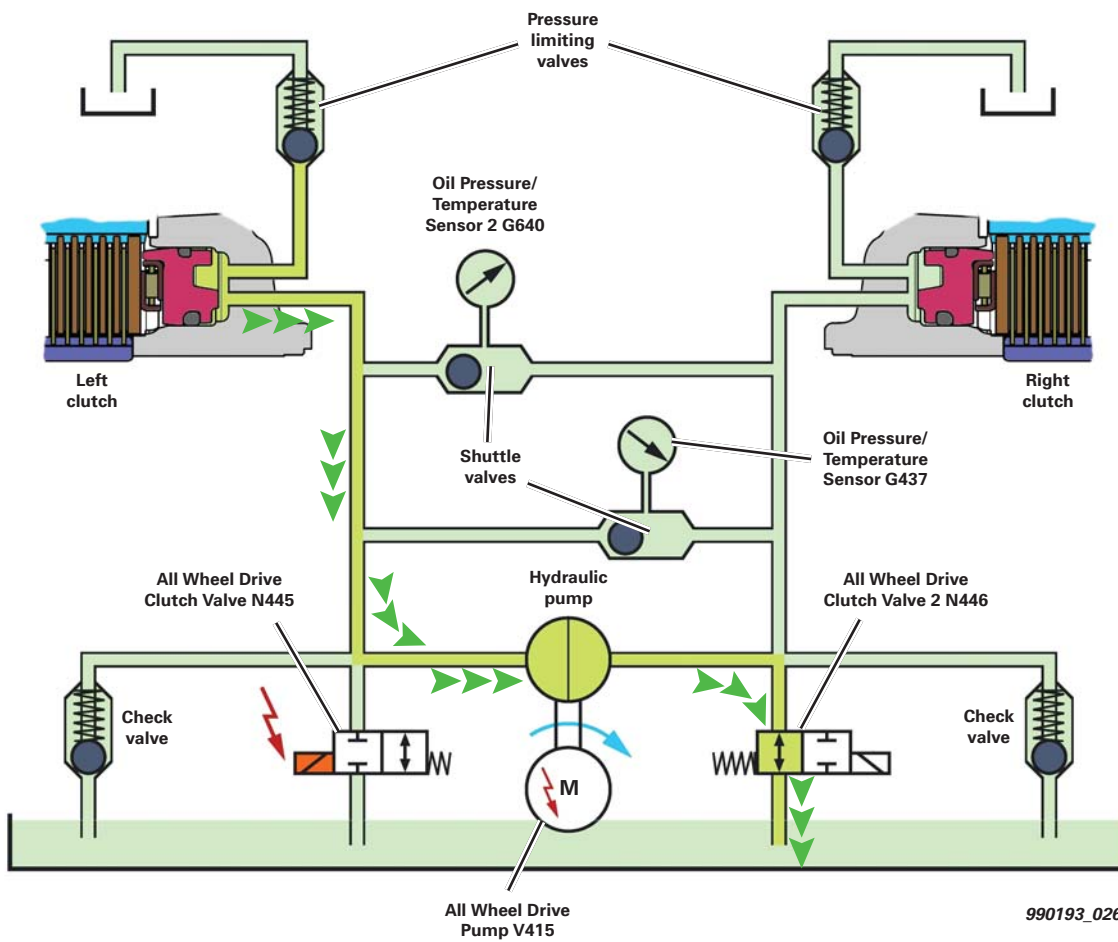

Sport Differential

Pressure Reduction 2

During the second stage of reduction, current flow to All Wheel Drive Clutch Valve N445 is removed allowing the valve to open. Hydraulic pressure is then released through the open valve.

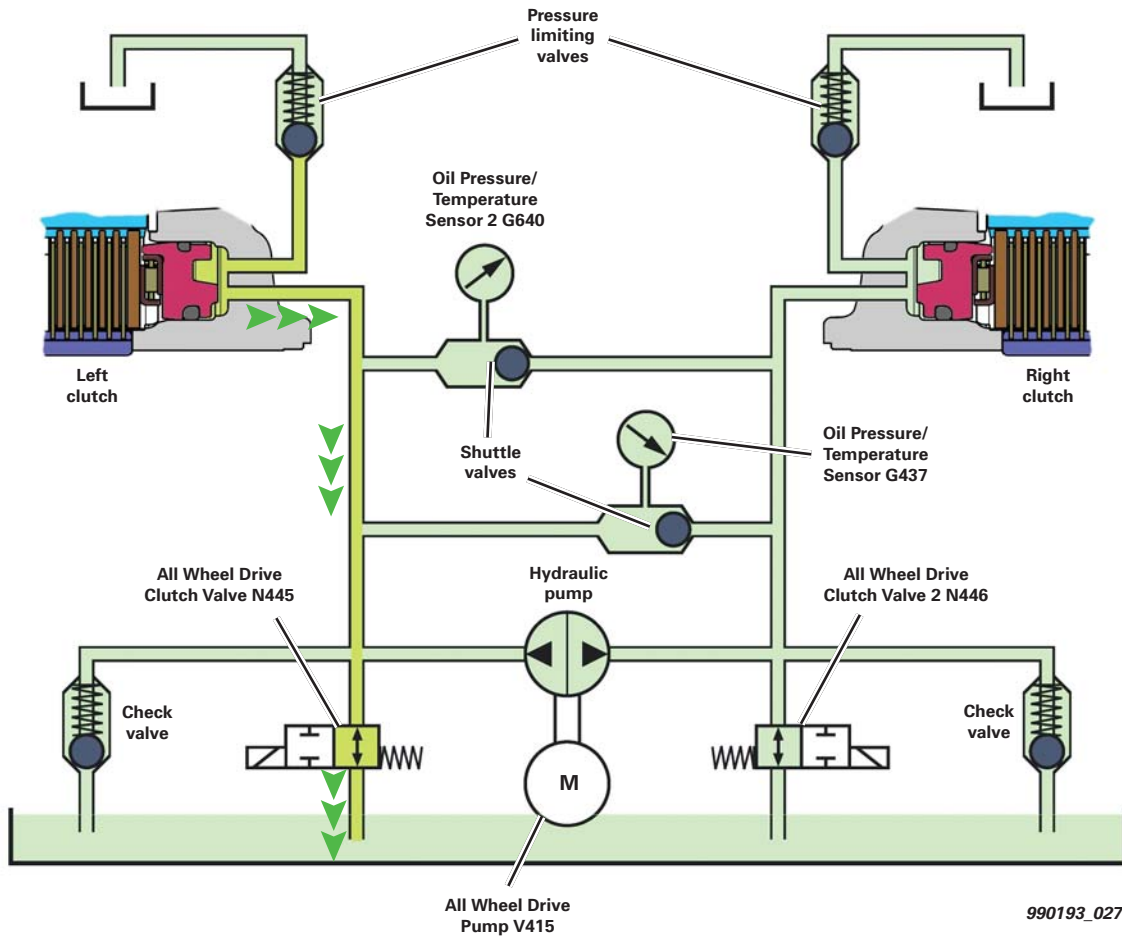

Sport Differential

The hydraulic system is vented at pre-determined intervals to eliminate the possibility of air compromising the system function. The requirements for activation are: engine idling and no wheel speed detected. Pressure is built up on each side alternately for a duration of approx. 100 – 200 ms until the pressure limiting valves open.

Any air in the hydraulic system will be vented with the oil returning to the sump. It is possible that some customers may hear the venting and consider it to be a problem rather than a normal operating function.

During service repairs that require adding fluid, a special bleeding procedure must be initiated through the VAS Scan Tool.

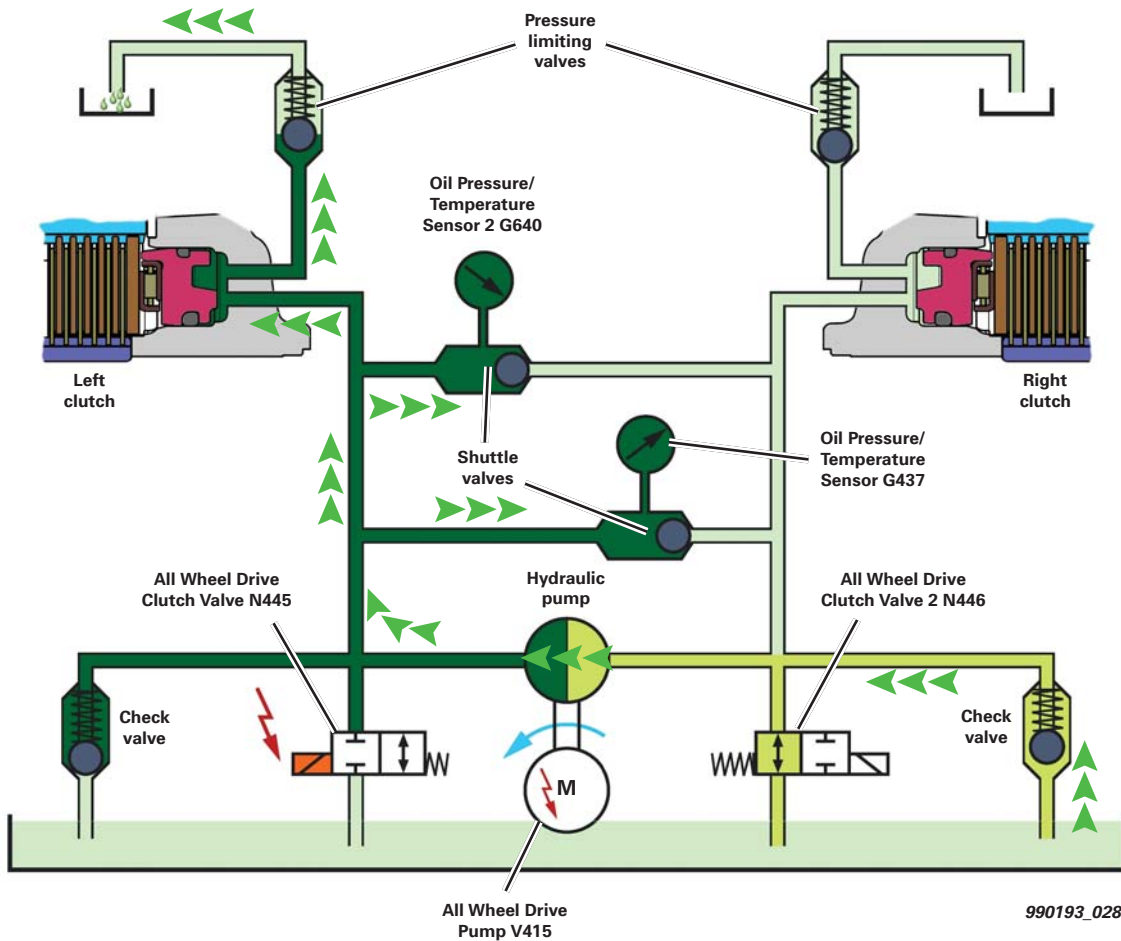

Sport Differential

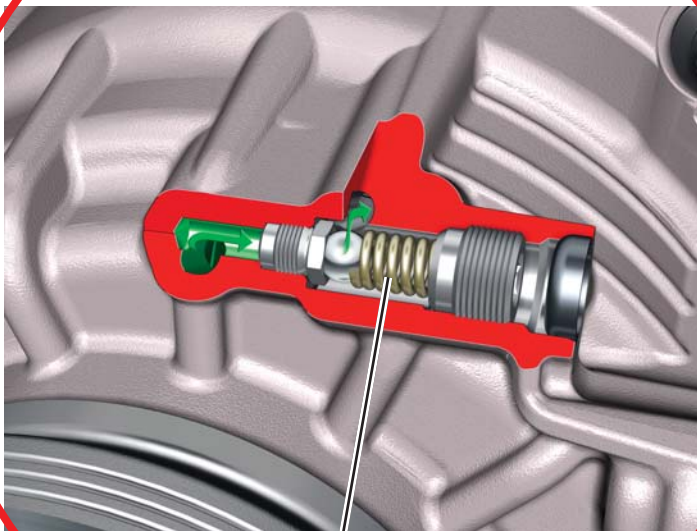
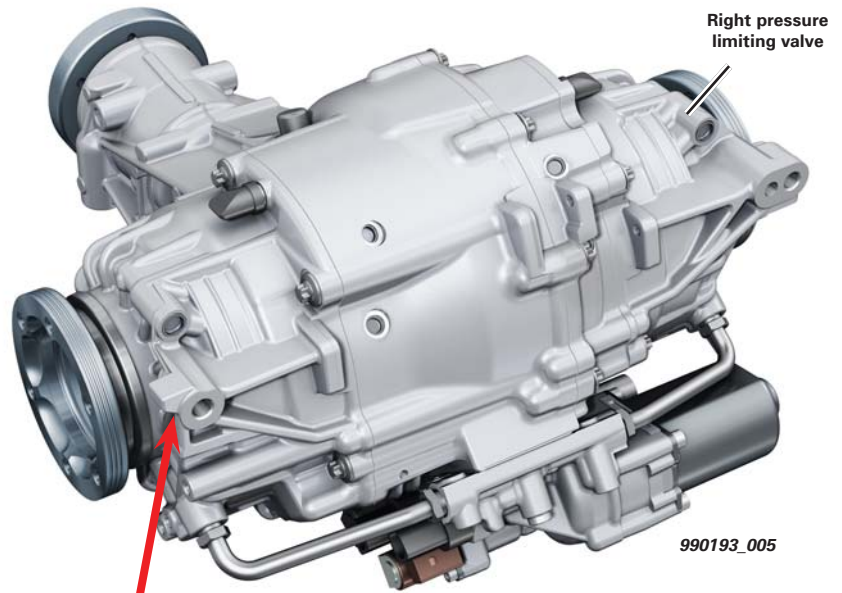

Important Service Notes

Both the ATF fill and hypoid gear oil fill are lifetime oils and do not require changing during routine scheduled maintenance. However, if repairs to the hydraulic controls are made, for example changing of the Oil Pressure/Temperature Sensors, All Wheel Drive Clutch Valves or hydraulic pump, the oil levels must be topped off. After this is done, a special bleeding process must be carried out via the scan tool.

Oil Pressure/Temperature Sensors G437 and G640 have their own serial numbers and characteristics. They are used to establish the identity of the sport differential for All Wheel Drive Control Module J492. They are color-coded and must not be installed in the wrong positions.

G437 and G640 should never (if possible) be replaced at the same time. Always replace one after the other. If this isn't done, All Wheel Drive Control Module J492 will assume a new sport differential has been installed and additional adaptation and maintenance procedures will be necessary, including changing of the ATF.

The speed modulation gearboxes (or super-position gearboxes) are tested and calibrated during the manufacturing process. The tolerances for each gearbox are inscribed on the sport differential housing in the form of a hexadecimal code. This code is used for adaptation via the VAS Scan Tool when repairs are made to the differential.

The VAS Scan Tool is used to diagnose the sport differential system. Information is found under Address Word 22.

In addition to doing adaptations and coding procedures, it is also possible to perform output check diagnosis. The output checks allow you to bleed the system, check the over-all functionality of the system, and to check the applied torque of the left and right clutches. This information is found in both Guided Functions and Guided Fault Finding.

Sport Differential

Displays/Warnings

If the sport differential malfunctions, two displays will be given to the driver via the Driver Information System in the instrument cluster.

The display at top right informs the driver of a general malfunction of the system. In this case, the system will shut down and the sport differential will not distribute torque as intended.

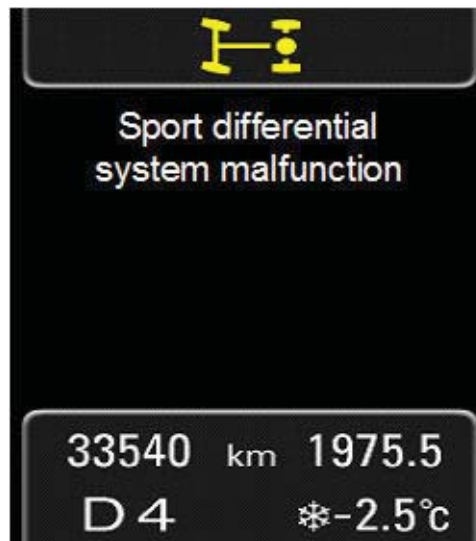

990193_030

The display at bottom right informs the driver that the temperature sensors have determined that the clutches have overheated. In this case, the system will not apply the clutches until the temperature is reduced, and the sport differential does not function.

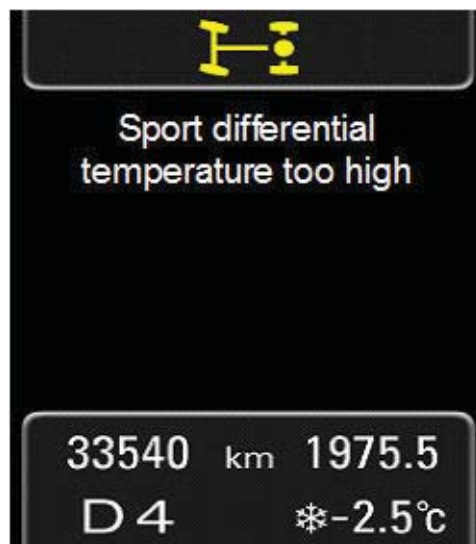

990193_033

Indirect Tire Pressure Monitoring

Beginning with the 2009 Audi A6, a new indirect tire pressure monitoring system was introduced to the North American market. This proven system has been used on Audi vehicles in other markets and will be available on all Audi vehicles in the near future.

With the indirect system, no actual tire pressures are measured. Instead, tire pressures are calculated by the Tire Pressure Monitoring (TPMS) control module. Wheel speed data from the wheel speed sensors is sent to the ABS control module and then to the TPMS control module. Through the process of wheel speed analysis and wheel spectrum analysis, the TPMS control module determines if the tires are inflated to correct pressure.

An under-inflated tire will have a smaller circumference than a properly inflated tire and therefore, turn at a faster speed. An under-inflated tire will also vibrate at a different frequency. This vibration frequency difference is detected through signals generated by the Wheels Speed Sensor (Wheel Spectrum Analysis) and helps determine which tire is under-inflated.

The system is designed to issue a warning when pressure loss is calculated to be 25% in one or more tires compared to tire pressures when the system was last reset.

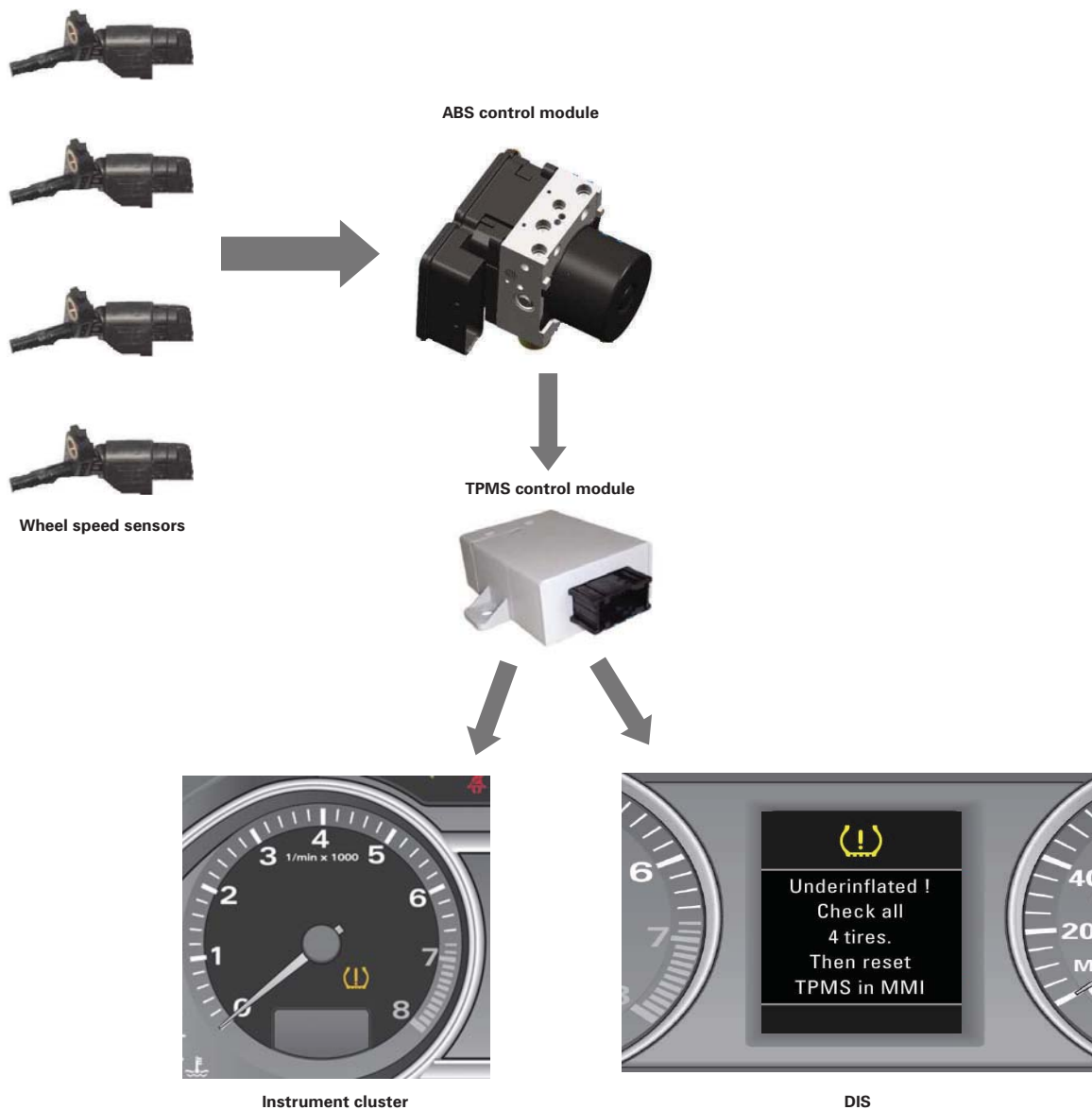

Indirect Tire Pressure Monitoring

This system is software based. No additional hardware is needed. There are no pressure sensors located in the wheels, no additional antennas, no special triggers. Therefore, all current hardware-related issues of direct TPMS (non-functioning tire pressure sensors, antennas, triggers, etc.) will be eliminated. Customers will not have to purchase additional tire pressure sensors for optional wheels or for winter/summer tire changes.

No individual tire pressures are displayed in the instrument cluster, or in the Driver Information System. The spare tire is not monitored.

To ensure accurate operation, the TPMS must be reset after the following service procedures:

- Tire/wheel rotation
- Tire/wheel changes. For example: changing from winter tires to summer tires, or when changing wheel sizes
- When a tire pressure change is made. For example, to meet recommended values or to change pressure due to an increased load change in the vehicle

The reset process is accomplished through the MMI in two steps.



Note

The TPMS will not give a warning about under-inflation if all tires are equally under-inflated. The system needs to see a difference of air pressures before it can make a determination to issue a warning. Therefore, it is critical that tire pressures are set to factory specifications when doing a system reset.



Indirect Tire Pressure Monitoring

Instrument Cluster Warnings

When the ignition is switched ON, Tire Pressure Monitoring Display Indicator Lamp K220 in the instrument cluster will light up for a few seconds and then go out. This is an indication to the driver that the system is functioning normally.

If the light remains on without flashing, it is an indication to the driver that a tire (or tires) with low pressure has been detected.



An additional text message will appear in the Driver Information System when a tire (or tires) with low pressure is detected. If only one tire with low pressure is detected, one of the following messages will be displayed:



Indirect Tire Pressure Monitoring

System Fault Indication

If the light comes ON and flashes for approx. one minute and then remains ON solid (no flashing,) it is an indication that there is a system fault in the TPMS. A warning will also be displayed in the Driver Information System.



Diagnosis procedures for the TPMS can be found with the VAS Scan Tool using Address Word 4C, Tire Pressure Monitoring II.

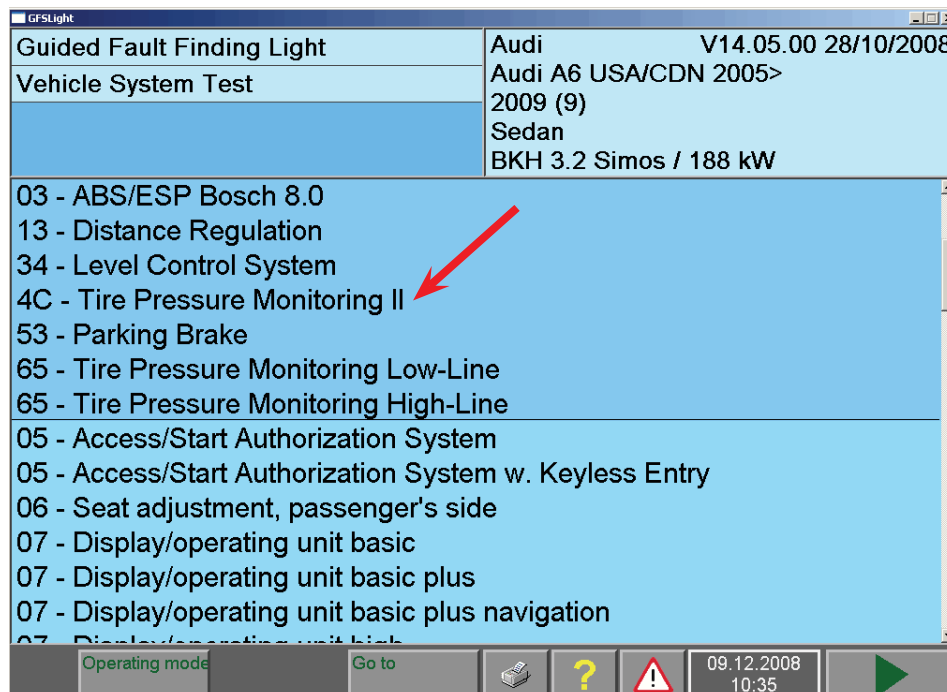

A third generation of the MMI — MMI 3G — has been developed by Audi. With a 40 GB hard drive (Navigation Plus only), a DVD drive, and high-speed processors, Audi's MMI system has become even more versatile and powerful.

The top-of-the-line version, MMI Navigation Plus (NAV Plus), is now the premium system. The basic operating principle of MMI 2G has been retained, but a new, innovative joystick control makes it easier to use. This joystick is located on the central knob and can be moved in eight directions.

MMI Navigation Plus has a large full color TFT display measuring 7" corner to corner. It is ergonomically located high up on the center console. With a resolution of 800 x 480 pixels and LED backlighting, this monitor produces a sharp image with exceptional contrast. Even in poor light conditions, colors stand out sharply against the black background.

The new central processor, Information Electronics Control Module 1, integrates into one unit, all functions previously assigned to as many as six separate control modules. Additional features, such as the SD card reader and hard drive, are integrated into the NAV Plus.

Another new component is the radio module. It updates tuner and sound system functions that previously had been assigned to as many as three control modules. All of which means that the total number of control modules in the MOST bus system has been greatly reduced.

Two versions of the MMI 3G will be offered: Basic Bluetooth and MMI Navigation Plus. NAV Plus Bluetooth will be available during the 2010 model year. MMI Navigation Plus was introduced in 2009 in the Audi Q5 and will be available in all 2010 models except the Audi A8. MMI 3G will be available in the A8 with the introduction of the D4 generation model.

**8-direction joystick control feature
now added to Navigation Plus**



435_050

Comparison of MMI 2G and MMI 3G Features

	MMI 2G	Navigation Plus	Enhancement	
Display	6.5" 1/4 VGA, resolution 480x240	7" VGA, resolution 800x480	Higher resolution, modernized menu appearance	
Radio	Scan diversity, single SDARS tuner	Phase diversity, double SDARS tuner	Better radio reception, dynamic SDARS station list	
Radio	CCDA, MP3 CD	CDDA / MP3 CD, SD card, DVD audio, HDD	SD card, DVD functionality, available HDD for music storage	
	N/A	DVD video, mpeg 4	Ability to watch video on front screen	
	iPod (MDI), USB, aux-in	iPod (MDI), USB, aux-in	3G allows user to load songs to HDD	
Telephone	SDS	Max. 150 address book entries, max. 1000 phone contacts, user created voice tags	Max. 5000 address book entries, max. 2000 phone contacts, user created voice tags or system created voice tags	More address book contacts, customer does not have to create voice tags for voice recognition operation
NAV		2D map, destination input using speller	2D or 3D mapping, destination using speller or voice recognition	More detail in NAV map, 3D objects in NAV map, simplified VR input

Comparison of Basic Bluetooth and Navigation Plus Features

		Basic Bluetooth	Navigation Plus
Display		6.5" 1/4 VGA, resolution 480x240	7" VGA, resolution 800x480
Radio		Scan diversity, single DAB/SDARS tuner	Phase diversity, double DAB/SDARS tuner
Radio		CCDA, MP3 CD	CDDA / MP3 CD, SD Card, DVD audio, HDD
		N/A	DVD video, mpeg 4
		iPod (MDI), USB, aux-in	iPod (MDI), USB, aux-in
Telephone	SDS	Max. 5000 address book entries, max. 2000 phone contacts, user created voice tags or system created voice tags	Max. 5000 address book entries, max. 2000 phone contacts, user created voice tags or system created voice tags
NAV		N/A	2D or 3D mapping, destination using speller or voice recognition

Control Module Topology for MMI 3G

The MOST bus is used for exchanging data between control modules of the MMI 3G system. It facilitates the high data transfer rate necessary for the transfer of audio data.

Video signals from the TV tuner or rearview camera are transmitted across an analog video line to Information Electronics Control Module 1 J794 as color video blanking signals (CVBS). This means all video signals are transmitted across a single cable.

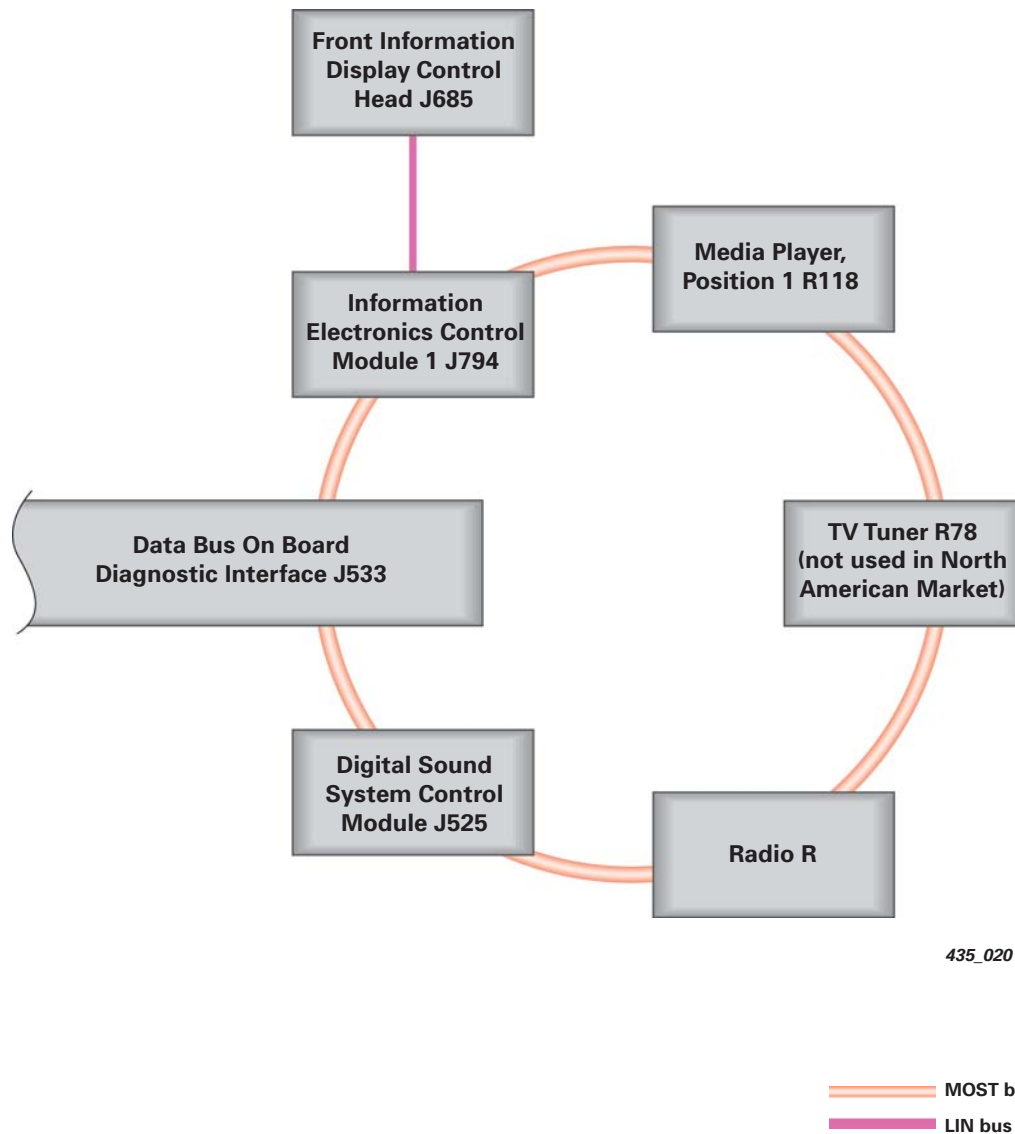

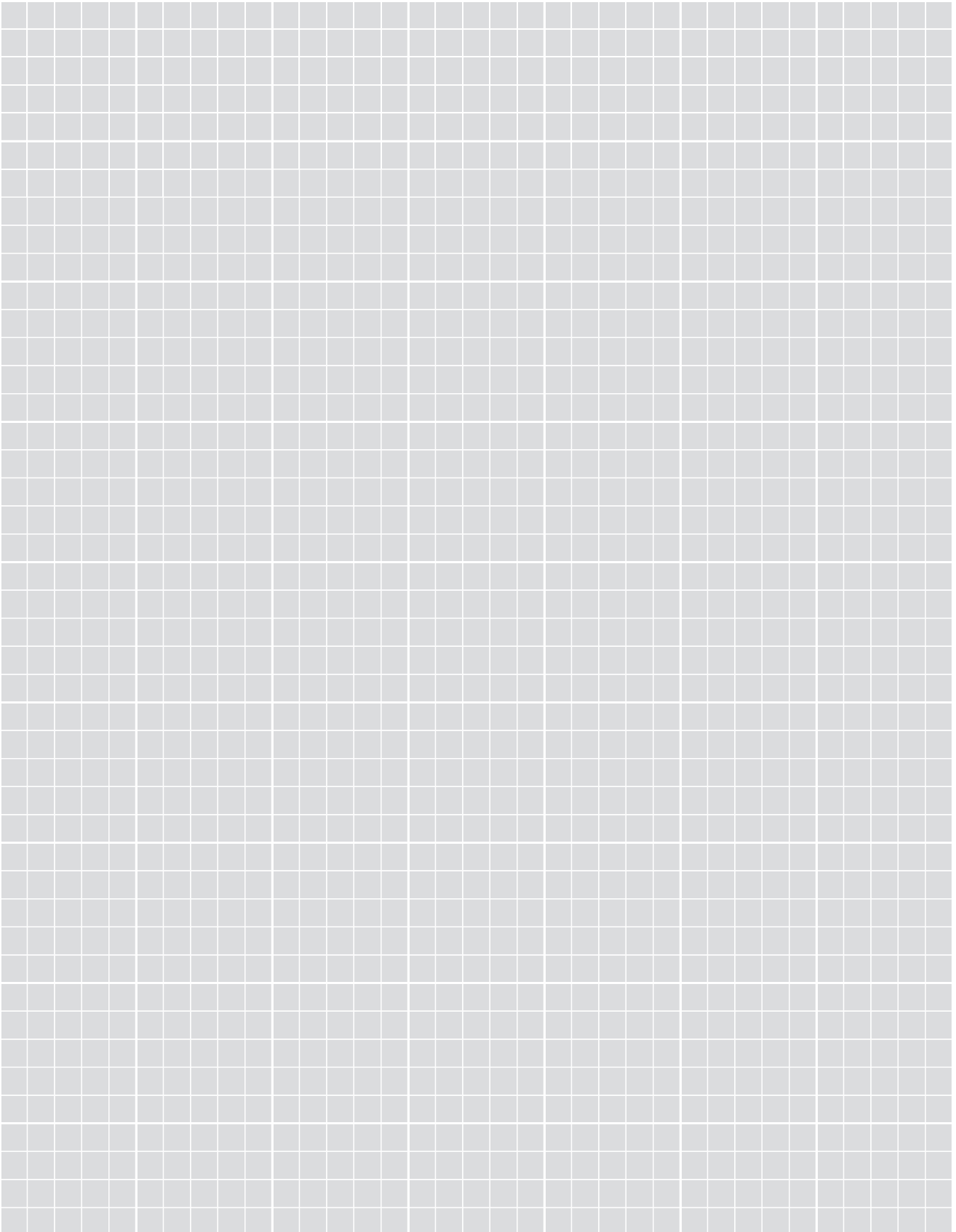

Overview

Information Electronics Control Module 1 J794 is the master control of the MMI infotainment system.

In the MMI 3G system, J794 is installed in the same position on every vehicle model.

Compared with the MMI 2G system, up to six previously independent control modules are now integrated into J794.

Even though the MMI Navigation Plus has more functions and options, it is over 9.9 lb (4.5 kg) lighter than the previous MMI 2G with navigation.

The following control modules have been integrated into J794:

- Front Information Display Control Head Control Module J523
- CD-Player R89 (single CD player)
- Navigation System with DVD Drive Control Module J401 (optional)
- Telephone Transceiver R36 (optional)
- Speech Input Control Module
- External Audio Source Connection R199 (Audi music interface) (optional)

Information Electronics Control Module 1 J794 can incorporate the following components:

- SD card reader
- Hard drive (only available in combination with MMI Navigation Plus)
- Audi Bluetooth car phone

Information Electronics Control Module 1 J794 has the Address Word 5F. All functions integrated into J794 can be diagnosed using this Address Word.

The illustration at right shows all standard and optional control modules.

* Voice recognition is not available for Media/Radio features.

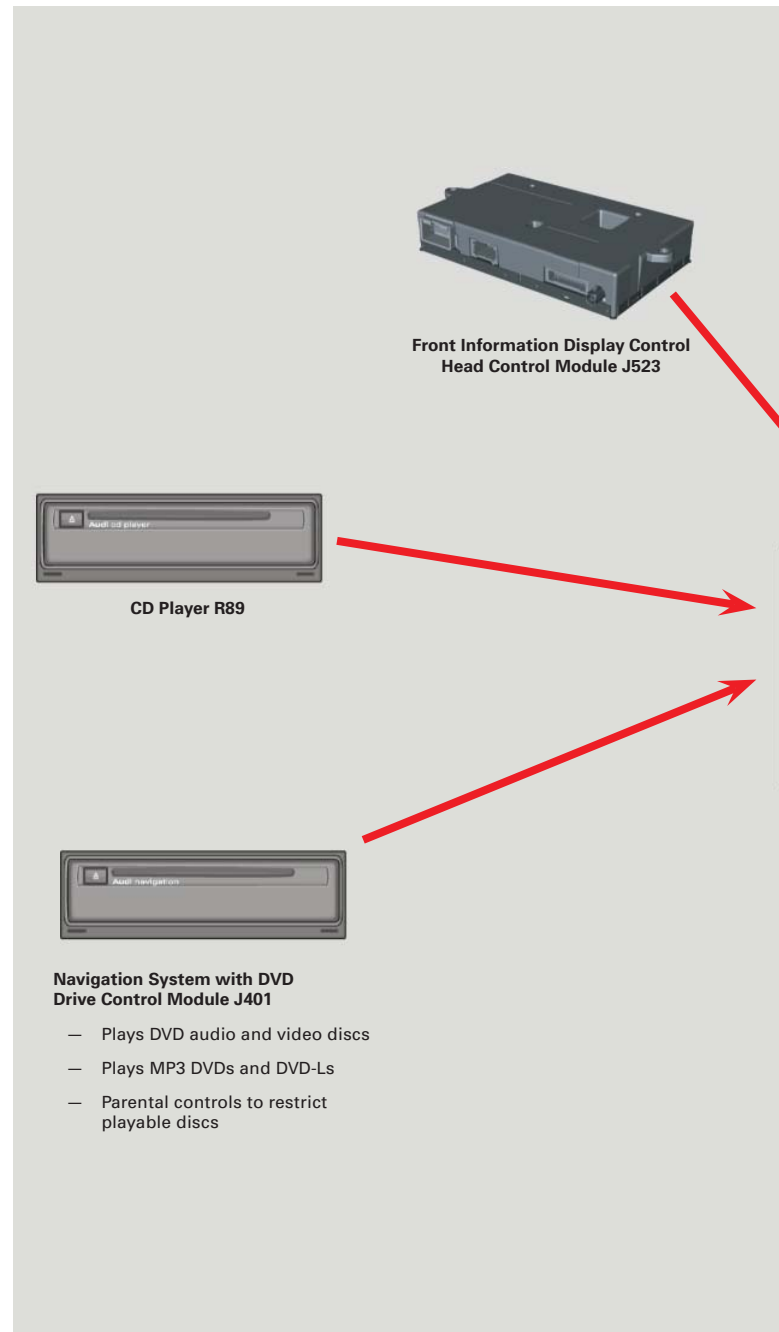

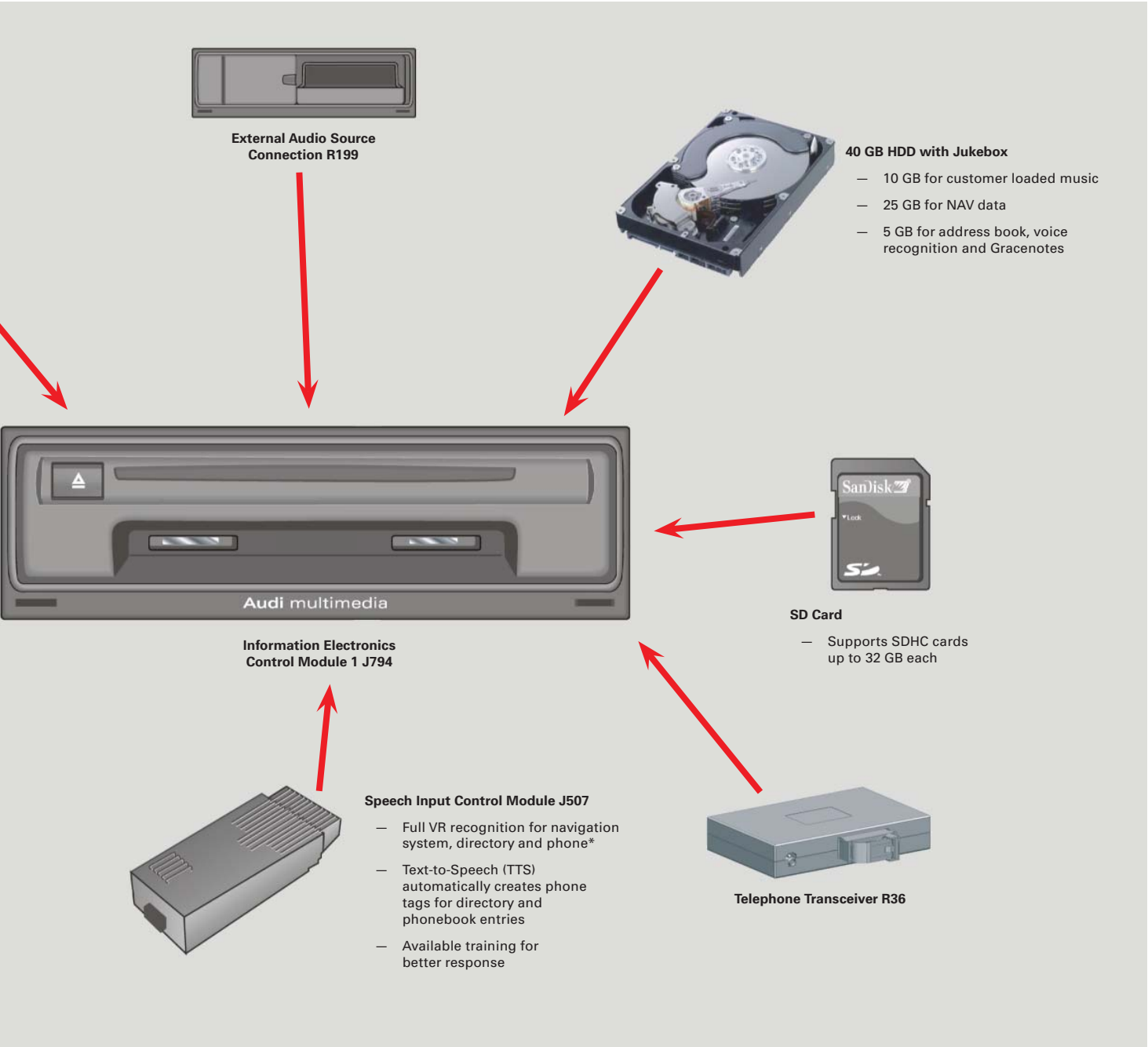

435_021

Front Information Display Control Head J685

Depending on version, MMI 3G has two different color displays. No monochromatic display is available.

The MMI Navigation Plus system features:

- 7" LCD in TFT technology
- Resolution: 800 x 480 pixels
- Size: 152.4 x 91.4 mm
- Connector color: gray

The Basic Bluetooth features:

- 6.5" LCD in TFT technology
- Resolution: 400 x 240 pixels
- Size: 143.4 x 79.3 mm
- Connector color: lilac

The screens are connected to J794 by a 4-pin SMBA (FAKRA standard) connector. This multi-pin connector is used to exchange data across a LIN bus line and transmit video signals across dual low voltage differential signaling (LVDS) lines. The video cables between Basic Bluetooth and the Navigation Plus system are not interchangeable. Power is supplied through a separate cable which is interchangeable.

Pop-Up Menus

In air conditioning settings display mode, the displayed settings are moved transparently across the current menu.

Video Signal Inputs

Information Electronics Control Module 1 J794 has two video inputs with different uses. The video signal from the optional TV tuner (not available in the North American market) is fed into the control module through a separate FAKRA connector.

The video signal from the optional rearview camera is fed in via two pins of the connector block.



Note

FAKRA is an international automotive industry supported organization that develops, adopts, and represents industry standards for measures, vehicle safety, and technical equipment, as well as manufacturing and testing. The term FAKRA connector refers to a specially standardized automotive connector.

LVDS stands for low voltage differential signaling. It is a standard for high-speed data transfer, with data transferred by relatively low, alternating (differential) voltage.

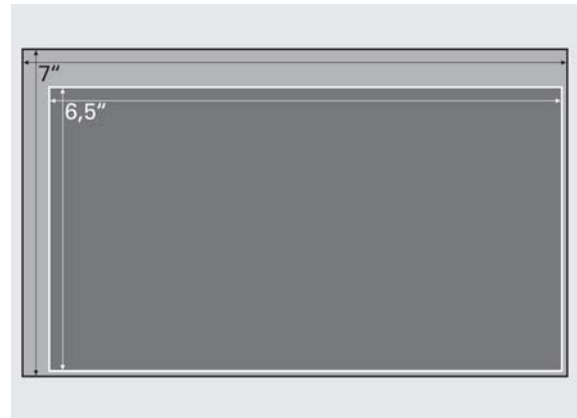

435_047



435_048

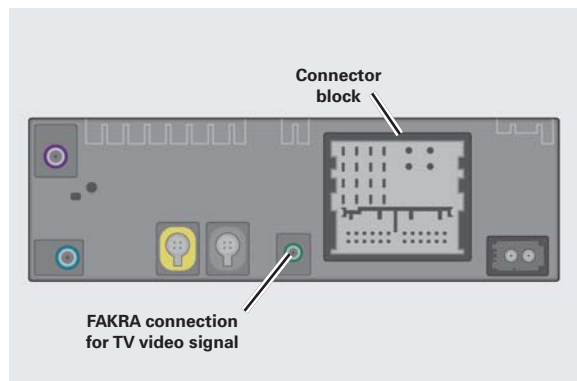

435_049

Multimedia Control Head E380

Multimedia Control Head E380 was adopted from MMI 2G.

The joystick feature is only available in combination with the MMI Navigation Plus system. The 8-way joystick is integrated in the central turn/push button.

The joystick can be used to move the crosshair cursor across the navigation map or to operate the main menu of a video DVD.



435_050

Component Protection

Information Electronics Control Module 1 J794 has a component protection feature.

When the component protection feature is active, all entertainment audio output sources are muted. A message text is displayed on the MMI when the system starts.

The audio outputs for telephone and navigation announcements remain active.

- * FAKRA — Technical Standards Committee of the Motor Vehicle Industry The FAKRA develops, adopts and represents standards in the automotive field. The term FAKRA connector refers to a specially standardized connector in automotive manufacture.
- * LVDS — Low Voltage Differential Signaling. An interface standard for high-speed data transfer. Data is transferred by relatively low, alternating (differential) voltage.



435_025a

Radio and Sound Systems

The analog radio, digital radio, and Audi sound system amplifier are all integrated into one unit. Premium sound systems such as Bose and Bang-Olufsen require an additional amplifier. When a premium sound system is installed in a vehicle, the integrated amplifier of the base radio is disabled.

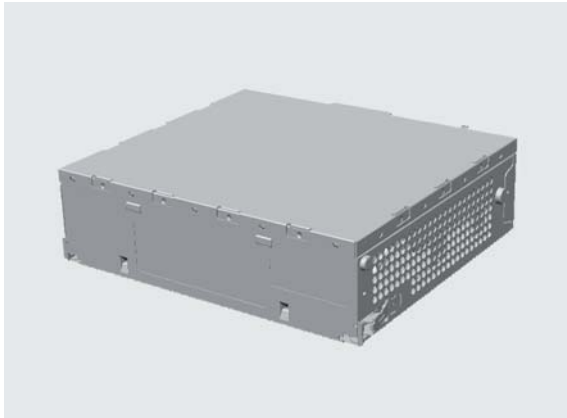

435_051

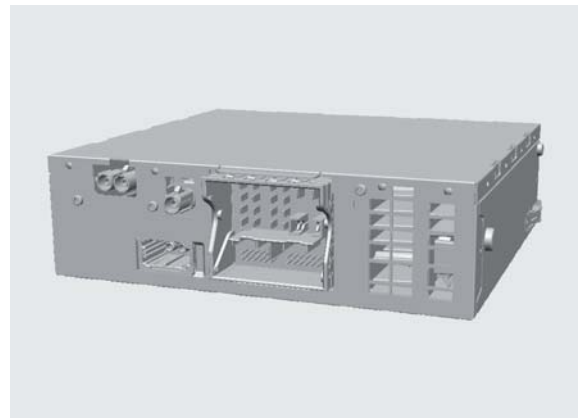

435_052

Analog Tuner Reception

Tuner 1 is an AM/FM tuner. AM reception is provided by tuner 1 only. Tuner 2 is an additional FM tuner. During FM reception, the selected station is received continuously through both tuners 1 and 2 simultaneously. The signals are then combined to create a composite signal.

Because station scanning is performed continuously, all receivable FM radio stations are displayed on the main screen of the FM radio menu. The station list is, therefore, updated on an ongoing basis, and stations no longer receivable are deleted from the list.

The separate station memory can be used to create a customized station list. Up to 50 stations from all reception bands can be selected and programmed by the user.

Radio Tuner Schematic

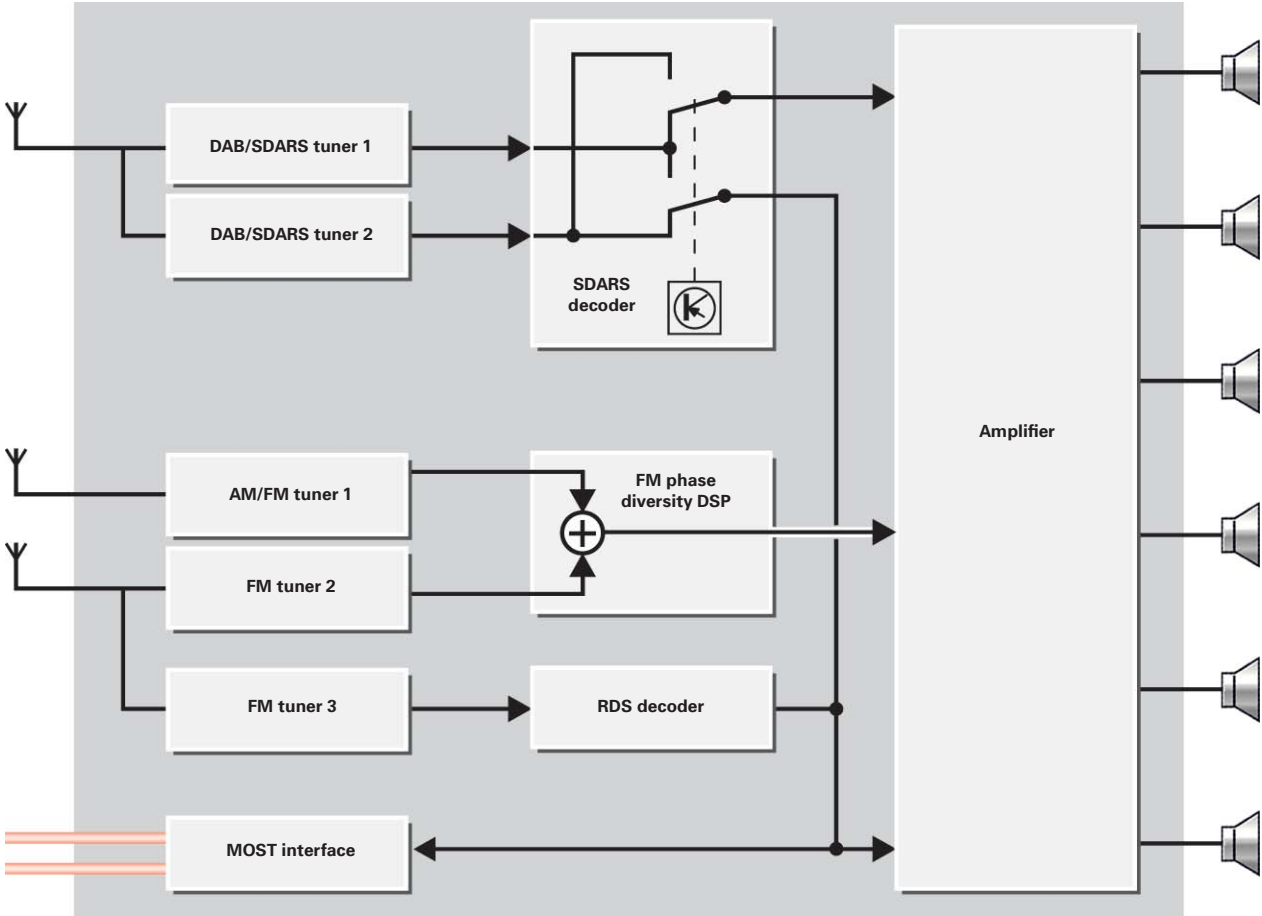

435_053

Station Scanning

FM Radio

The frequency bands and inter-channel spacing between individual FM stations vary from country to country. The radio station scanning function is matched to the different inter-channel spacing according to radio version and how the radio is encoded. In detail, these are:

FM radio for Europe and rest of world	87.5 MHz - 108.0 MHz	0.1 MHz scan increments
FM radio for North and South America	87.9 MHz - 107.9 MHz	0.2 MHz scan increments
FM radio for Japan	76.0 MHz - 90.0 MHz	0.1 MHz scan increments

MW (AM) Radio

Depending on country code, the following frequency bands are available in the radio:

MW radio for Europe and rest of world	531 kHz - 1602 kHz	9 MHz scan increments
MW radio for North and South America	530 kHz - 1710 kHz	10 MHz scan increments
MW radio for Japan	531 kHz - 1602 kHz	9 MHz scan increments
MW radio for Australia	531 kHz - 1602 kHz	9 MHz scan increments

Commercial Traffic Information Services

Commercial TMC data providers have been in operation for some time now. Commercial traffic information services broadcast their information in an encrypted form. This TMC data is relayed from the radio directly to the navigation module.

To allow this encrypted data to be evaluated, rights-managed software is integrated into the navigation control module. In the MMI 3G, the navigation control module is integrated with Information Electronics Control Module 1 J794.

TMC data varies from country to country. In the USA, Audi TMC data is supplied by Sirius Satellite Radio.

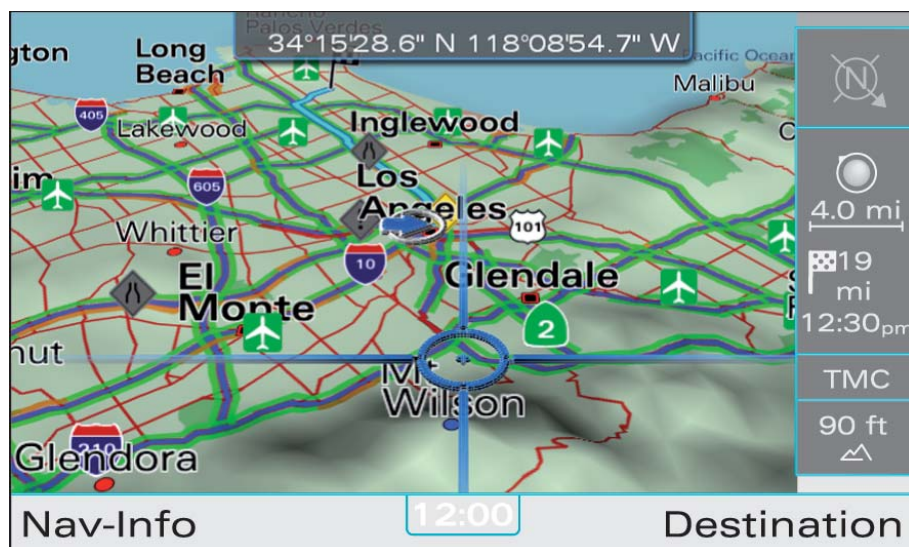

435_005

Digital Radio

The radio in the MMI 3G optionally supports two different digital radio systems. DAB is available virtually worldwide, while the SDARS tuner is designed exclusively for the North American market.

DAB is optional while the SDARS unit for North America is always integrated into the radio tuner.

SDARS Tuner for North America

The SDARS tuner receives programs from SIRIUS satellite radio.

For the first time, the digital tuner can now evaluate SAT TMC information. This pay-on-demand TMC data for the North American market is much more detailed than similar information available in Europe. Customers must have a SIRIUS traffic subscription to use TMC. Currently, customers cannot get just traffic, they must also subscribe to radio programming.

Traffic messaging data comes from several different sources and is, on average, up to half an hour old.

With this system, speed and flow data is transmitted. This data is then displayed on the navigation screen. Speed and flow data is not available for every street.

The system will not automatically reroute the driver unless:

- Route guidance is active
- An incident is major enough to justify rerouting
- A valid alternate route is available and the estimated ETA is shorter than merely driving through the incident

An additional Electronic Serial Number (ESN) is required when activating SDARS service for customers. One ESN is required for normal satellite programming while the second ESN is needed for traffic information data.

If a new radio is installed, it is important to record both ESNs, if possible, before removing the old radio.



435_056a

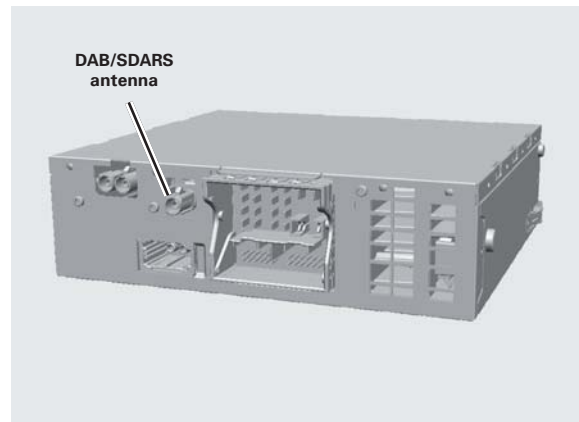

435_052



435_058



435_005

Amplifier in Radio

An audio amplifier is integrated in radio R, depending on sound system version. A separate amplifier is, therefore, not always necessary. The individual models are listed below together with their sound systems and respective amplifiers.

A3, A4, A5, Q5, A6, Q7		
Audi Sound System (standard)	6-channel amplifier	180 watt amplifier power
Premium Sound System (Bose)	External amplifier	
A8, Q7		
Premium Sound System (Bose)	External amplifier	
Premium Sound System (Bang-Olufsen)	Two external amplifiers	

Sound Systems

The Audi sound system consists of radio R, together with an integrated six-channel amplifier and a total of 10 speakers (11 speakers in the Audi Q7).

All speakers are connected to radio R. The radio receives all audio signals from other control modules, such as the CD changer, via MOST bus, relaying them to the speakers.

All diagnostic functions for the Audi sound system can be found using Address Word 56.

All premium sound systems (Bose, Bang-Olufsen) have external amplifiers. The total number of speakers varies from model to model. The amplifiers were adopted from the MMI 2G, with software adapted to the new features of the MMI 3G. The accompanying speakers and microphones for noise compensation are unchanged compared with MMI 2G. For details of each sound system, refer to the Self-Study Programs covering the respective vehicles.

All diagnostic functions of the premium and advanced sound systems can be found using Address Word 47.



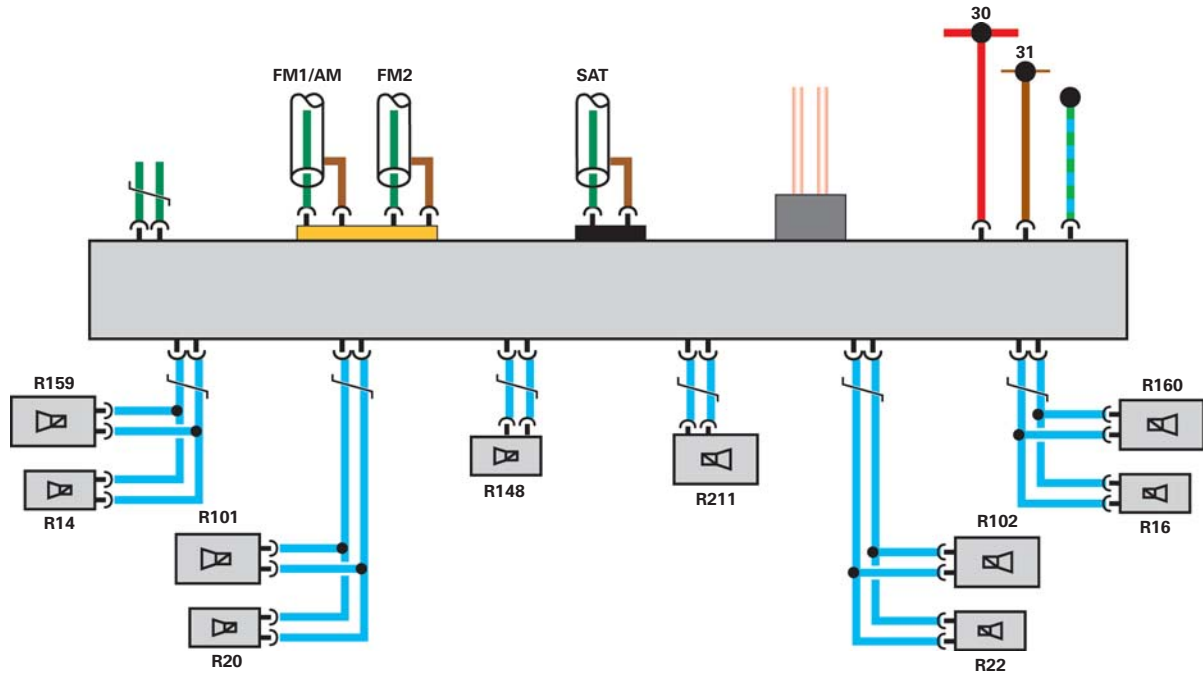



Functional Diagram – Audi Sound System



435_062

Legend

- R14 Left Rear Treble Speaker
- R16 Right Rear Treble Speaker
- R20 Left Front Treble Speaker
- R22 Right Front Treble Speaker
- R101 Left Front Mid-Bass Speaker
- R102 Right Front Mid-Bass Speaker
- R148 Center Speaker
- R159 Left Rear Mid/Low Range Speaker
- R160 Right Rear Mid/Low Range Speaker
- R211 Subwoofer

-  MOST
-  Output
-  Input
-  Terminal 30
-  Terminal 31
-  Bi-Directional

Surround Sound with DVD Playback

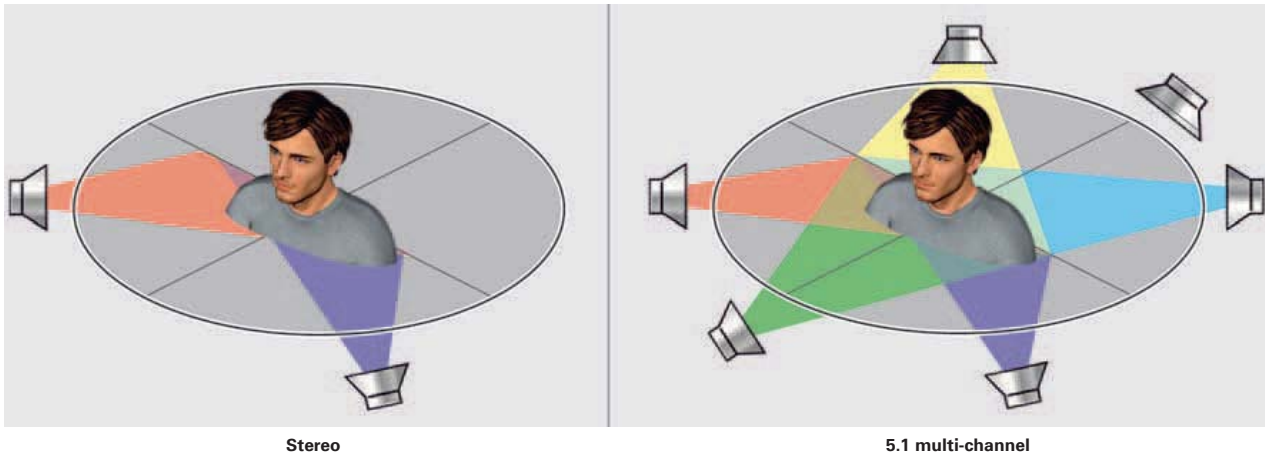

Stereo

5.1 multi-channel

With DVD videos, the Dolby Digital, or DTS (Digital Theatre System) audio format is often used for sound reproduction. Both systems save audio signals to six different channels. In technical terms, this is also known as 5.1 multi-channel sound.

The individual channels are:

- Front left
 - Front center
 - Front right
 - Rear left
 - Rear right
 - Subwoofer → 1
- } 5
- } 5.1

MMI 3G transfers audio from DVDs to premium sound system amplifiers through six separate audio channels. This provides an authentic DVD sound experience.

All other media (CD, digital radio, FM radio, MP3) are transferred to the amplifier in stereo. If a surround setting for stereo sources is selected in the MMI audio setup, the signals to the surround speakers in the amplifier are slightly delayed compared with signals to the other speakers. This creates an ambient effect unique to the customer vehicle.

Diagnostics

Diagnostics for MMI 3G are similar to those for MMI 2G. Remember that many of the functions of separate 2G modules are now integrated into 3G modules.

The “module order” that exists in the red engineering menu on the MMI 2G also exists on the MMI 3G, however, it is basically non-functional and should NOT be used to aid in diagnosis. Instead, use Measuring Value Blocks in Address Word 19 for diagnosing communication issues.

On systems where the amplifier is integrated with the radio, both the radio and the amplifier can be addressed using Address Word 56.

Antenna Diagnostics

Radio phase diversity now simplifies diagnosis of AM/FM antennas in MMI 3G. Both the AM/FM1 antenna and the FM2 antenna are now fully diagnosable. This means that a faulty cable on the downstream side of the antenna amplifiers can now be detected and a DTC is entered in the fault memory.

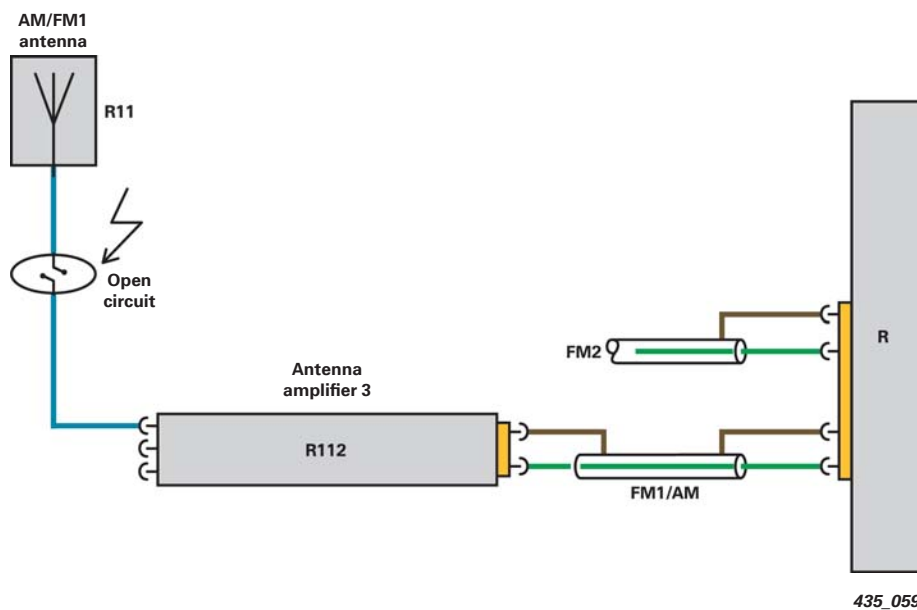

Sound Configuration

The sound configuration is the numeric values used to adapt the integrated digital equalizer to the vehicle interior. The amplifier receives sound parameters computed individually for the vehicle online from a software database.

Consequently, the sound parameters can then be easily optimized by means of an online update, without having to replace the complete amplifier software. This vehicle-specific configuration replaces previous coding information used in the amplifiers for vehicle, body shape, engine and seat upholstery (fabric/leather), etc.

Component Protection

The radio control module has a component protection feature. When the component protection function is active, its response varies according to trim level:

Radio with external amplifier:

The audio signal is interrupted cyclically for one second during AM/FM/Sirius reception.

Radio with internal amplifier:

The audio signal is interrupted cyclically for one second during AM/FM/Sirius reception. In addition, the left audio channel is muted for all entertainment sources. Telephone calls and navigation directions are transmitted unobstructed.

Installation Location and Attachment

The radio is located in the luggage compartment on the left side, behind the trim cover in the Audi A4, A5, Q5, A6 and A8 (D3).

The radio is made with two different housings. A version with a spring clip attachment system is, for example, used on the Audi A6, so the radio fits into the existing mounting bracket in the luggage compartment. The version with screw plate attachment system is used on the Audi A8 (D3) only.

Software Update

The MMI 3G software can be flashed using the CD in the CD/DVD drive of Information Electronics Control Module 1 J794.

MOST control modules can also be flashed via the SD card reader of Information Electronics Control Module 1 J794 using an SD card, or at the Audi music interface (External Audio Source Connection R199) using a USB memory stick.



435_064

Encoding

MMI 3G can only be encoded using software version management (SVM).

No information on encoding the control modules of the MMI 3G is available other than through SVM.

This simplifies encoding at the dealership and helps to avoid malfunctioning of the control modules because of incorrect encoding.



435_065

Replacing Control Modules

If a fault occurs in a component of Information Electronics Control Module 1 J794, then the module has to be replaced completely.

In the MMI Navigation Plus system, customer data can be saved before removing a defective unit, without the customer having to re-enter any personal settings or data.

This saved customer information can include stored address books, navigation destinations and various sound settings. The system will not back-up the Jukebox feature.



435_066

Note

Online encoding applies to MMI 3G on all vehicles.



Knowledge Assessment

An on-line Knowledge Assessment (exam) is available for this Self-Study Program.

The Knowledge Assessment may or may not be required for Certification.

You can find this Knowledge Assessment at:

www.accessaudi.com

From the accessaudi.com Homepage:

- Click on the “ACADEMY” tab
- Click on the “Academy Site” link
- Click on the “CRC/Certification” link
- Click on Course Catalog and select “990193 – Audi New Technology 2009 – 2010”

For assistance please call:

Audi Academy
Certification Resource Center (CRC)
1-877-283-4562
(8:00 a.m. to 8:00 p.m. EST)

Or you may send an email to:

audicrhelpdesk@touchstone-group.com

990193

All rights reserved.
Technical specifications subject
to change without notice.

Audi of America, LLC
2200 Ferdinand Porsche Drive
Herndon, VA 20171