



## The 3.2 and 3.6 liter FSI Engine

Self Study Program 924603

Audi of America, Inc.  
Service Training  
Printed in U.S.A.  
Printed 10/2006  
Course Number 924603

©2006 Audi of America, Inc.

All rights reserved. All information contained in this manual is based on the latest information available at the time of printing and is subject to the copyright and other intellectual property rights of Audi of America, Inc., its affiliated companies and its licensors. All rights are reserved to make changes at any time without notice. No part of this document may be reproduced, stored in a retrieval system, or transmitted in any form or by any means, electronic, mechanical, photocopying, recording or otherwise, nor may these materials be modified or reposted to other sites without the prior expressed written permission of the publisher.

All requests for permission to copy and redistribute information should be referred to Audi of America, Inc.

Always check Technical Bulletins and the latest electronic repair information for information that may supersede any information included in this booklet.

Trademarks: All brand names and product names used in this manual are trade names, service marks, trademarks, or registered trademarks; and are the property of their respective owners.

# Table of Contents

<b>Overview</b> . . . . .	<b>1</b>
---------------------------	----------

<b>Engine Mechanics</b> . . . . .	<b>5</b>
-----------------------------------	----------

The Crank Assembly .....	5
The Cylinder Head.....	8
Camshaft Adjustment.....	9
Internal Exhaust Gas Recirculation.....	10
Crankcase Ventilation.....	11
The Intake Manifold.....	13
The Chain Drive .....	16
The Ribbed V-belt Drive.....	17
Oil Circulation.....	18
Coolant Circulation.....	21
The Exhaust System .....	23
FSI Technology.....	24

<b>Engine Management</b> . . . . .	<b>30</b>
------------------------------------	-----------

System Overview .....	30
Sensors .....	32
Actuators .....	43
The Control Modules in the CAN Data-Bus.....	49

<b>Operating Diagrams</b> . . . . .	<b>50</b>
-------------------------------------	-----------

<b>Service</b> . . . . .	<b>55</b>
--------------------------	-----------

Actuators .....	55
-----------------	----

<b>Knowledge Assessment</b> . . . . .	<b>57</b>
---------------------------------------	-----------

The Self-Study Program provides introductory information regarding the design and function of new models, automotive components or technologies.

**The Self-Study Program is not a Repair Manual!**  
**All values given are intended as a guideline only and refer to the software version valid at the time of publication of the SSP.**

For maintenance and repair work, always refer to the current technical literature.

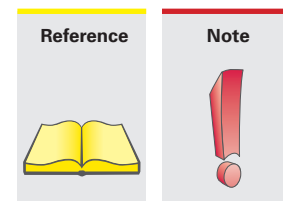





The 3.2L and the 3.6L V6 FSI engines belong to the narrow V family of engines. Their reduced V-angle, compared with a traditional V-engine, gives them an extremely compact and space-saving design.

The 3.2L narrow V6 engine was first introduced to Audi in the the TT and later the A3. This narrow V engine design is highly desirable for use in smaller vehicles due to the compact design.



S360\_401



S360\_402

The 3.2L and 3.6L V6 FSI engines are the newest representatives of the narrow V family of engines.

While the 3.2L version was first introduced in the Audi TT, the 3.6L FSI version is making its debut in the Audi Q7.

The displacement was increased from 3.2 liters to 3.6 liters, combined with the switch to the FSI technology. This yields a noticeable increase in power and torque compared with the 3.2L engine.

The 3.6L FSI engine has a maximum rated power of 280 hp (206 kW) and produces a maximum torque of 265 lb.ft (360 Nm). These two compact engines have substantial reserves of power on the road and a dynamic torque curve.

#### Special features of both engines:

- Retention of external dimensions
- FSI direct gasoline injection
- Four-valve technology with roller rocker arms
- Internal exhaust gas recirculation
- Single-piece variable-length intake manifold made of plastic
- Weight-reduced cast iron crankcase
- Chain drive located on the transmission side with integral drive for the high-pressure fuel pump
- Continuously variable intake and exhaust camshafts

The use of FSI direct fuel injection technology makes it possible to meet current Low Emission Vehicle (LEV2) emission standards.

## Technical data for the 3.2L V6 Engine

Construction	6 cylinders narrow V engine
Displacement	193.3 cu.in (3168 cm <sup>3</sup> )
Bore	3.4 in (86 mm)
Stroke	3.58 in (90.9 mm)
V Angle	10.6°
Valves per cylinder	4
Compression ratio	12:1
Max Output	250 hp (184 kW) @ 6250 rpm
Max Torque	243 lbs.ft (330 Nm) @ 2750-3750 rpm
Engine management	Motronic MED 9.1
Exhaust emission control	Three-way catalytic converters with O2 sensors
Emission standard	LEV2

Torque-power curve

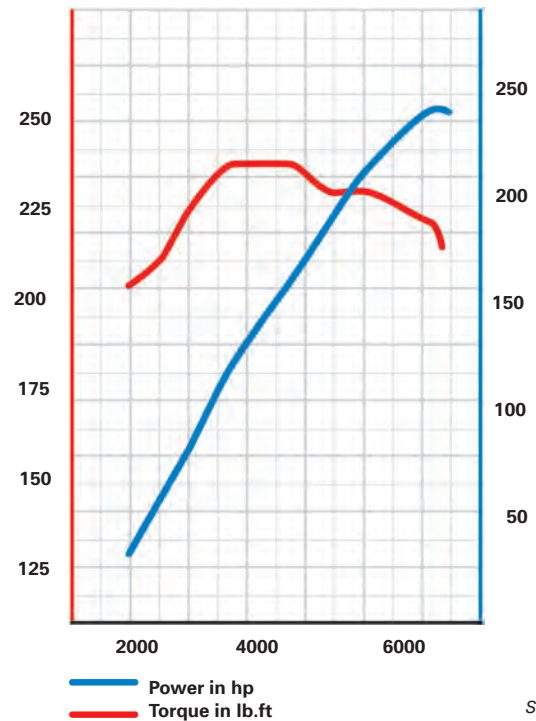

S360\_116

## Technical data for the 3.6L V6 FSI Engine

Construction	6 cylinders narrow V engine
Displacement	219.5 cu.in (3597 cm <sup>3</sup> )
Bore	3.5 in (89 mm)
Stroke	3.8 in (96.4 mm)
V Angle	10.6°
Valves per cylinder	4
Compression ratio	12:1
Max Output	280 hp (206 kW) @ 6200 rpm
Max Torque	265 lbs.ft (360 Nm) @ 2500-5000 rpm
Engine management	Motronic MED 9.1
Exhaust emission control	Three-way catalytic converters with O2 sensors
Emission standard	LEV2

Torque-power curve

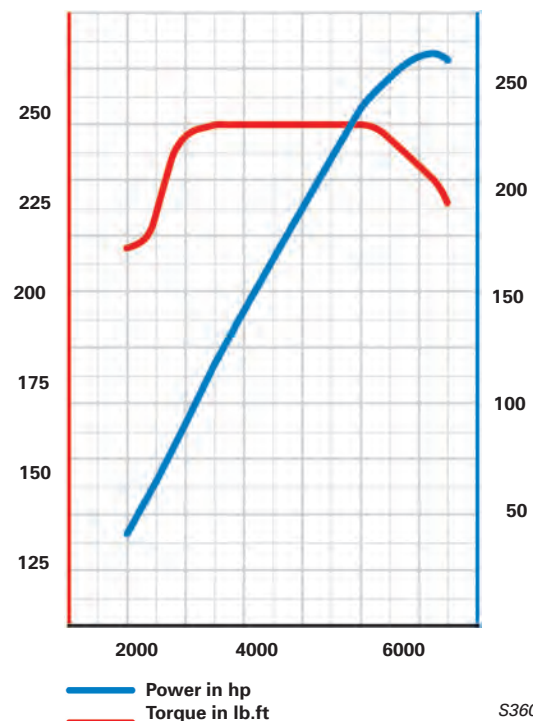

S360\_115

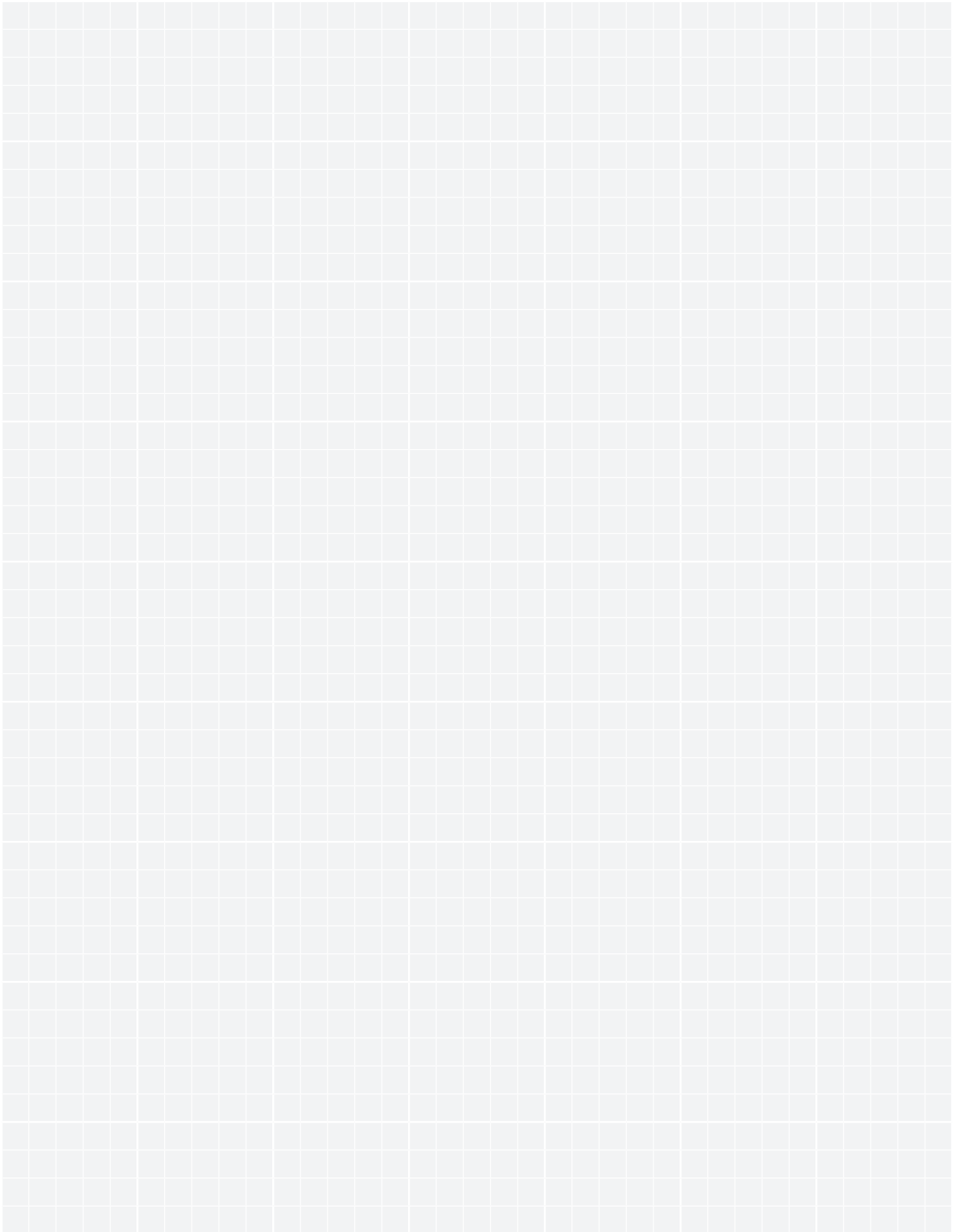

## The Crank Assembly

## The Cylinder Block

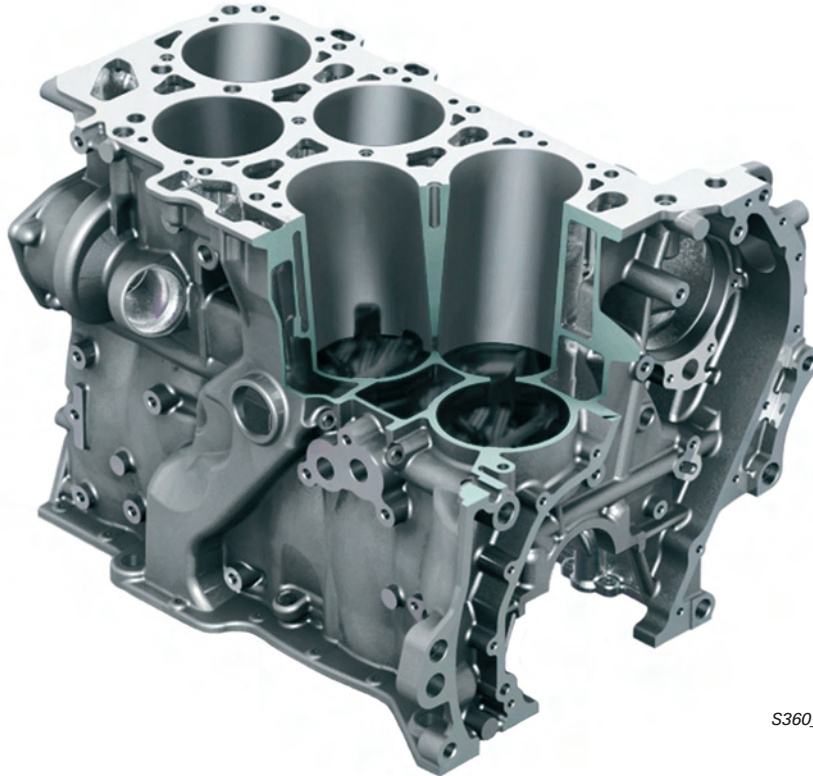

S360\_004

The cylinder block has been significantly redesigned compared with the 3.2L manifold injection engine.

The goal of the revision was to obtain a displacement of 3.6 liters without changing the exterior dimensions of the engine. This was achieved by changing the V-angle and the offset.

Both FSI engines, the 3.2L and the 3.6L, have the new cylinder block. It is made of cast iron with lamellar graphite.

Further innovations compared with the 3.2L manifold injection engine include:

- Oil pump integral with the cylinder block
- Better oil return from the cylinder block to the oil pan
- Improved cylinder block rigidity, while reducing weight at the same time
- Volumes of coolant in the cylinder block reduced by 0.7 liter, allowing the coolant to heat up faster.

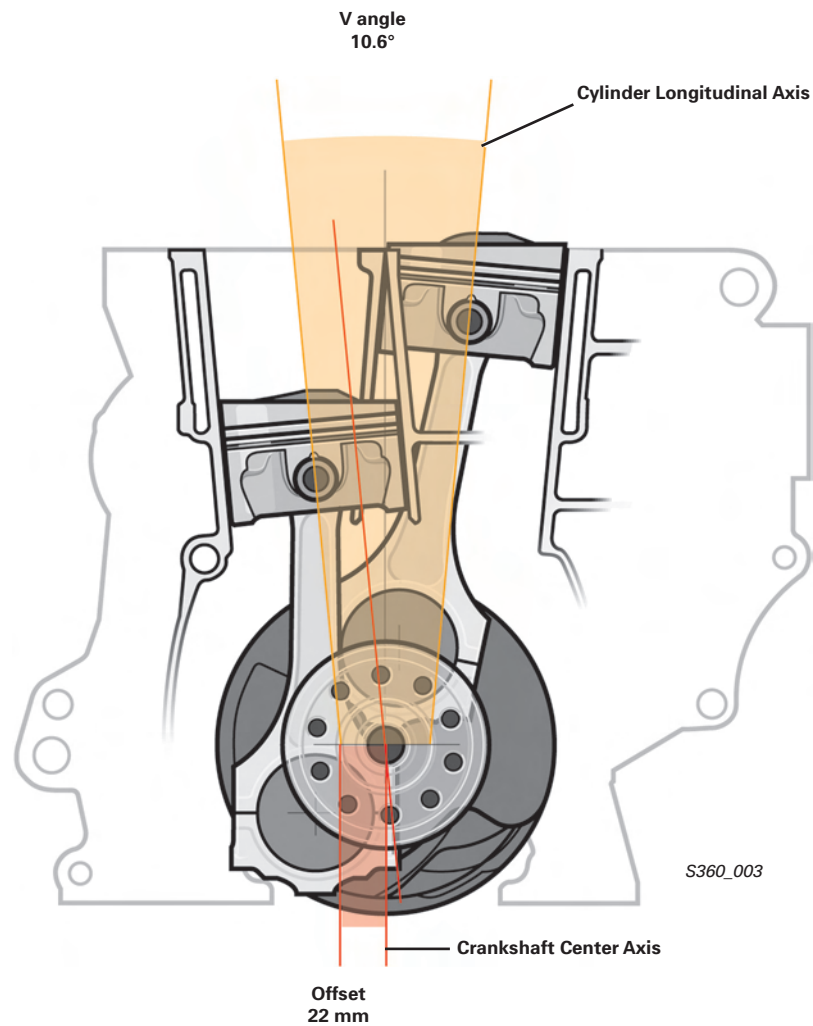

## The V-angle

The V-angle of the cylinder block is 10.6°.

By changing the V-angle from 15° to 10.6°, it was possible to provide the necessary cylinder wall thickness without changing the dimensions of the engine.

## Offset

By reducing the V-angle, the cylinder longitudinal axis moves outward relative to the bottom of the crankshaft.

The distance between the cylinder longitudinal axis and the crankshaft center axis is the Offset.

The Offset is increased from 12.5 mm to 22 mm compared with the manifold injection engine.



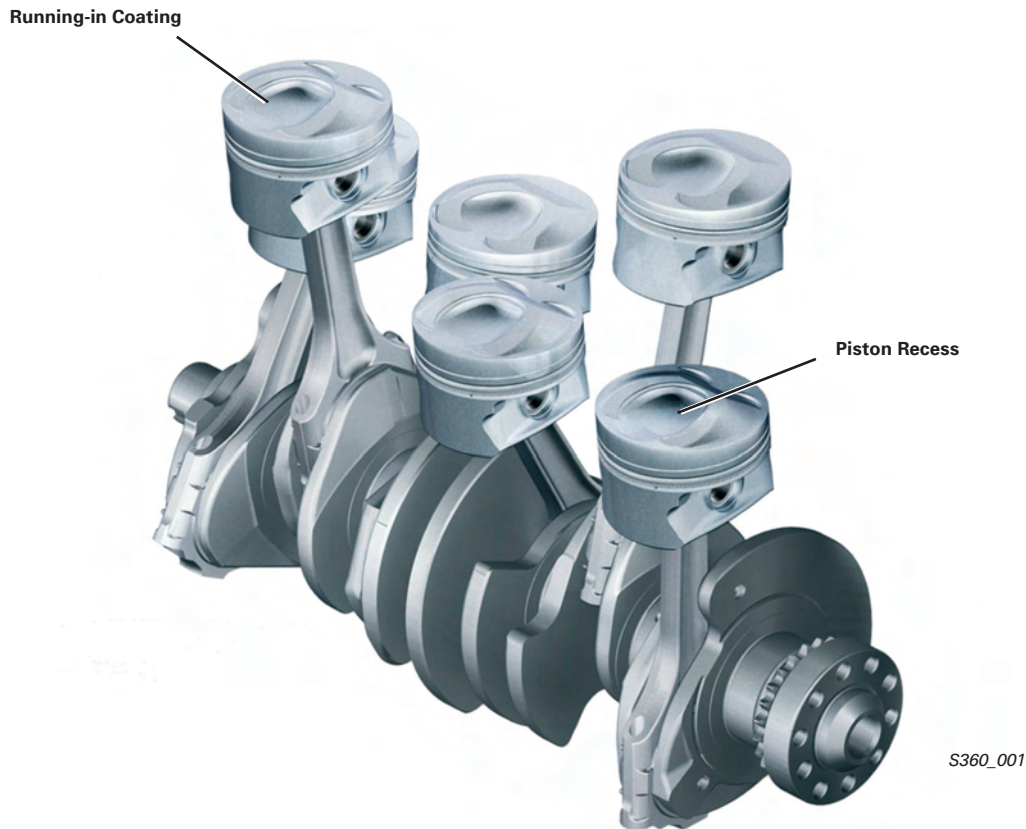

## The Crankshaft

The crankshaft is made of cast iron and is carried by 7 bearings, as in the 3.2L manifold injection engine.

## The Pistons

The pistons are of the recessed piston design and are made of aluminum alloy. In order to improve break-in characteristics, they have a graphite coating.

The pistons are different for the cylinder bank 1 and the cylinder bank 2. They differ in the arrangement of the valve pockets and the combustion chamber recess.

The location and design of the piston recess generates a swirling motion of the injected fuel and mixes it with the intake air.

## The Connecting Rods

The connecting rods are not cast but milled. The connecting rod eye is a trapezoidal design. The connecting rod bearings are molybdenum coated. This provides good break-in characteristics and high load capacity.

## The Cylinder Head

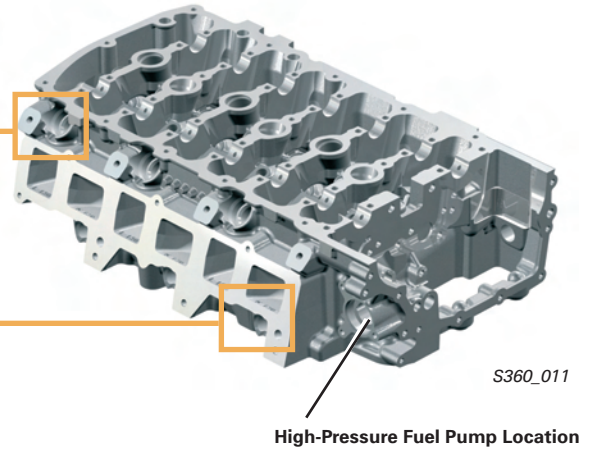
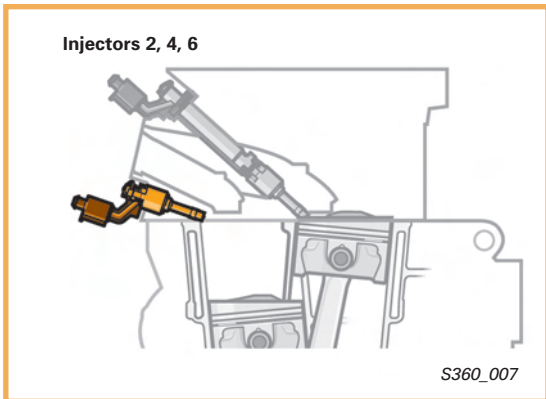
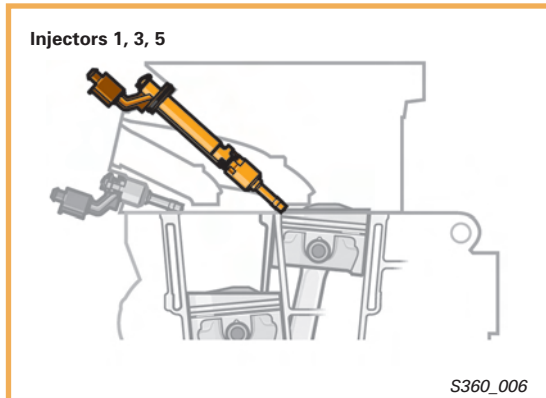

The cylinder head is made of an aluminum-silicon-copper alloy and is identical for both engines. It is a new design as a result of the direct fuel injection.

The cylinder head has been lengthened to accommodate the chain drive and to strengthen the high-pressure fuel pump mounting location.

The fuel injectors for both cylinder banks are located on the intake side of the cylinder head.

The fuel injectors bores for cylinders 1, 3 and 5 are located above the intake manifold flange. The fuel injectors for cylinders 2, 4 and 6 are installed below the intake manifold flange.

As a result of this layout, the fuel injectors for cylinders 1, 3 and 5 pass through the cylinder head intake manifold.

In order to compensate for the effect of the fuel injectors on the airflow characteristics in the intake manifold, the valve spacing for all cylinders has been increased from 34.5 mm to 36.5 mm. This reduces the change in airflow direction resulting from the fuel injectors when filling the cylinders



### Note

Fuel injectors of two different lengths are required because of the two different positions for the fuel injectors.



## Camshaft Adjustment

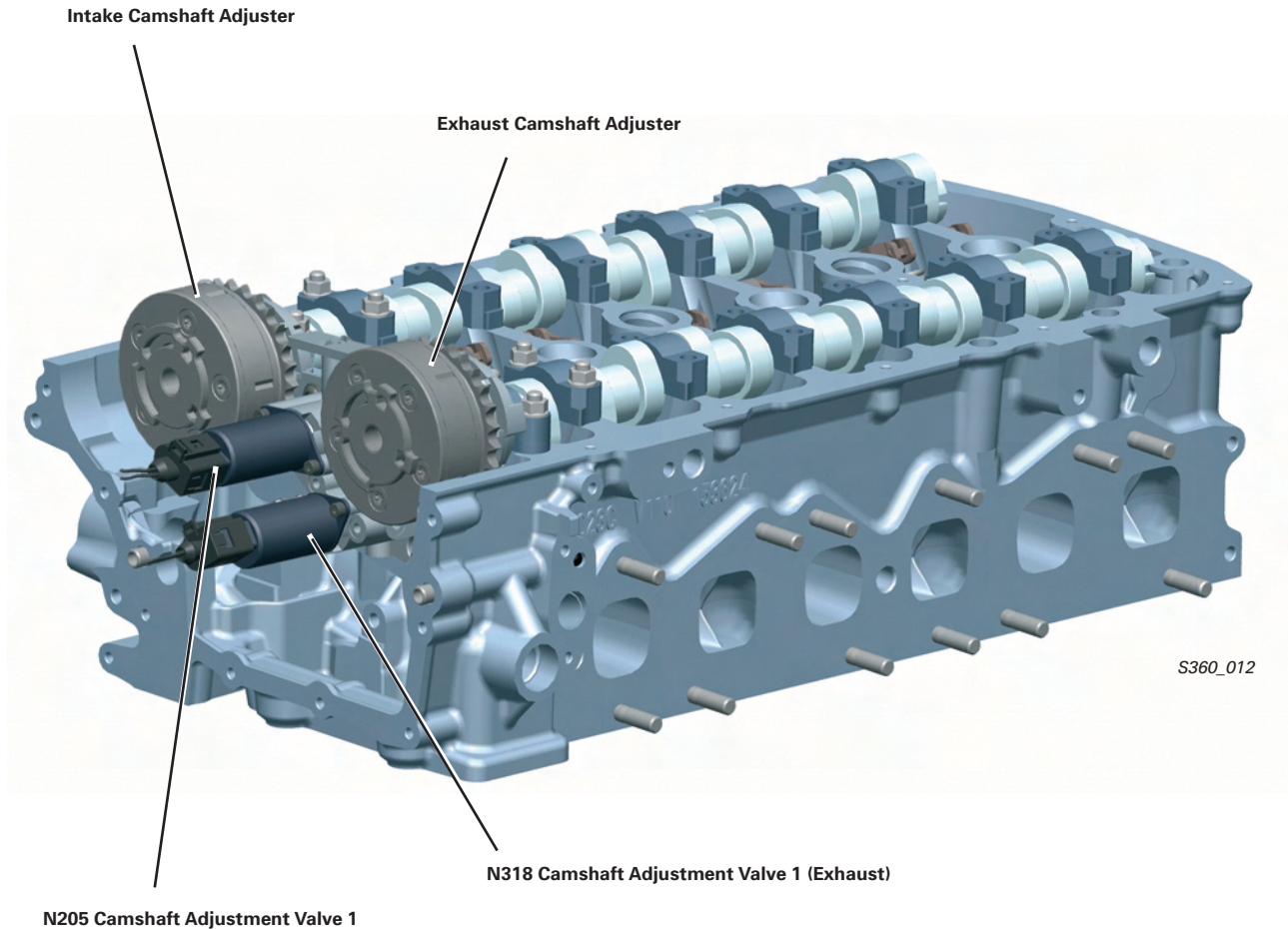

By adjusting the camshafts, power and torque can be increased, fuel consumption can be improved and emissions reduced, depending on the load characteristics of the engine.

The camshafts are adjusted by two vane type adjusters. Both camshafts can be adjusted continuously in the direction of early valve opening and late valve opening.

To adjust the camshafts, the Engine Control Module (ECM) actuates the solenoids:

- N205 Camshaft Adjustment Valve 1 and
- N318 Camshaft Adjustment Valve 1 (exhaust).

Maximum adjustment of the camshafts:

- Intake camshaft 52° from the crankshaft angle and
- Exhaust camshaft 42° from the crankshaft angle.

Both camshaft adjusters are adjusted by two valves with the assistance of the engine oil pressure.

Adjusting both camshafts enables a maximum valve overlap of 42° crankshaft angle. The valve overlap allows for internal exhaust gas recirculation.

## Internal Exhaust Gas Recirculation

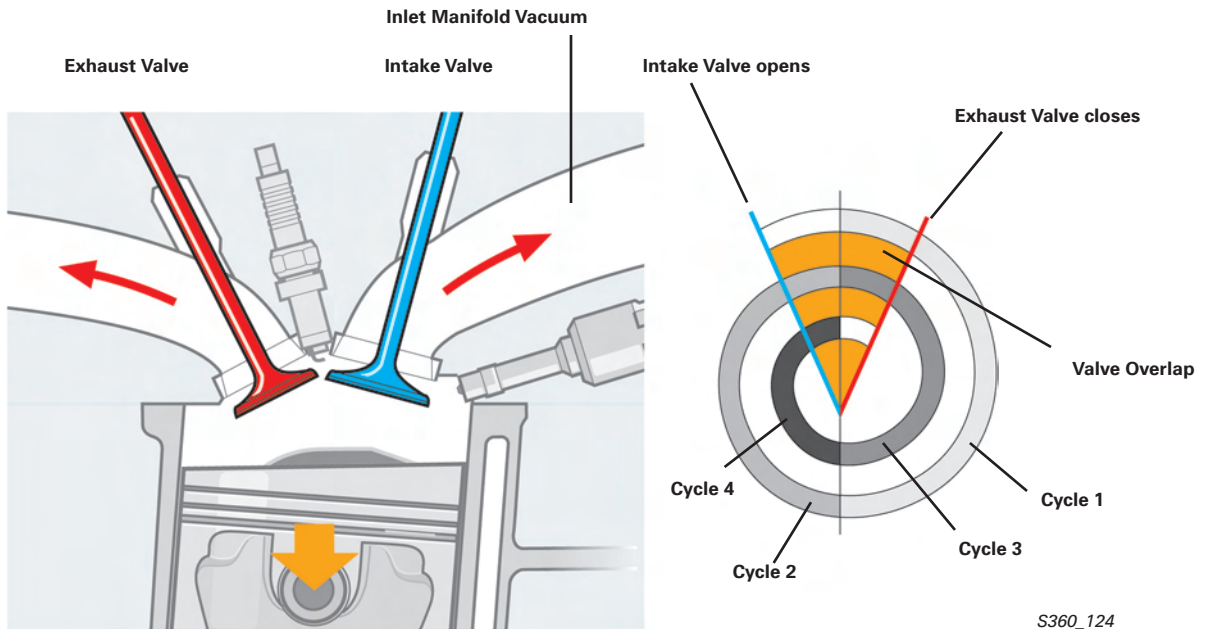

S360\_124

Internal exhaust gas recirculation counteracts the formation of nitrous oxides (NO<sub>x</sub>).

Just as with external exhaust gas recirculation, the reduced formation of NO<sub>x</sub> is based on lowering combustion temperature by introducing combustion gases.

The presence of combustion gases in the fresh fuel-air mixture produces a slight oxygen deficit. Combustion is not as hot as with an excess of oxygen.

Nitrous oxides are not formed in greater concentrations until a relatively high temperature is reached.

By reducing combustion temperature in the engine and with the lack of oxygen, the formation of NO<sub>x</sub> is reduced.

## Operation

During the exhaust stroke, the intake and the exhaust valves are both open simultaneously. As a result of the high intake manifold vacuum, some of the combustion gases are drawn out of the combustion chamber back into the intake manifold and swirled into the combustion chamber with the next induction stroke for the next combustion cycle.

Benefits of the internal exhaust gas recirculation:

- Improved fuel consumption due to reduced gas exchange
- Partial load range expanded with exhaust gas recirculation
- Smoother idle
- Exhaust gas recirculation possible even with a cold engine

## Crankcase Ventilation

It prevents hydrocarbon-enriched vapors (blow-by gases) from escaping from the crankcase into the atmosphere. Crankcase ventilation consists of vent passages in the cylinder block and cylinder head, the cyclone oil separator and the crankcase ventilation heater.

### Operation

The blow-by gases in the crankcase are drawn out by intake manifold vacuum through:

- vent ports in the cylinder block,
- vent ports in the cylinder head,
- a cyclone oil separator and
- a crankcase ventilation heater

The blow-by gases are then rerouted into the intake manifold.

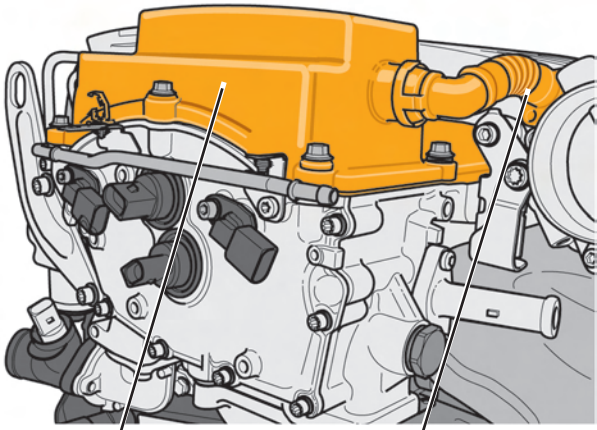

Cyclone Oil Separator      Crankcase Ventilation Heater

S360\_064

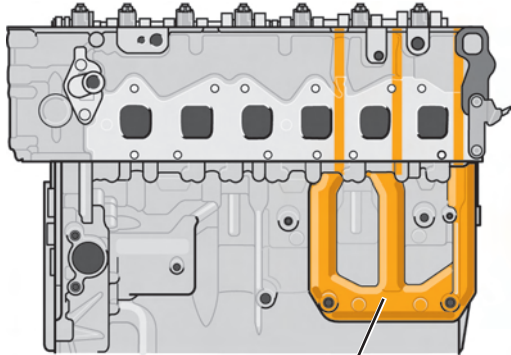

Ventilation Ports in the Cylinder Block and Cylinder Head

S360\_253

## The Cyclone Oil Separator

The cyclone oil separator is located in the cylinder head cover. Its function is to separate oil from the blow-by gases from the crankcase and to return it to the primary oil circuit.

A pressure regulator valve limits the intake manifold vacuum from about 700 mbar to about 40 mbar.

It prevents the entire intake manifold vacuum and the internal crankcase vacuum from affecting the crankcase ventilation and drawing in engine oil or damaging seals.

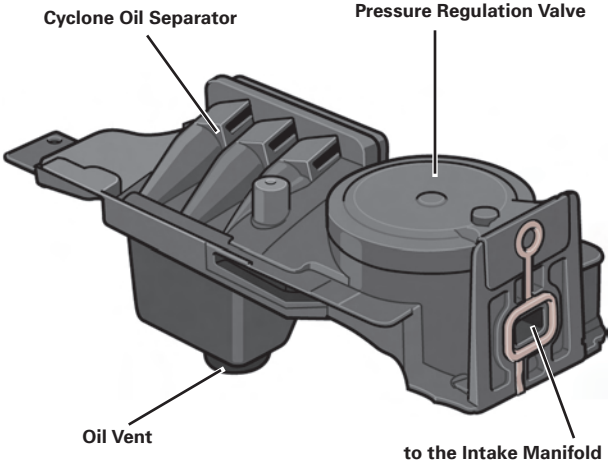

to the Intake Manifold

S360\_058

# Engine Mechanics

## Operation

The cyclone oil separator separates the oil from the oil vapor drawn in. It works on the principle of centrifugal separation.

Due to the cyclone design of the oil separator, the oil vapors drawn in are set into a rotating motion. The resulting centrifugal force throws the oil against the separating wall where it combines into larger drops.

While the separated oil drips into the cylinder head, the gas particles are routed into the intake manifold through a flexible tube.

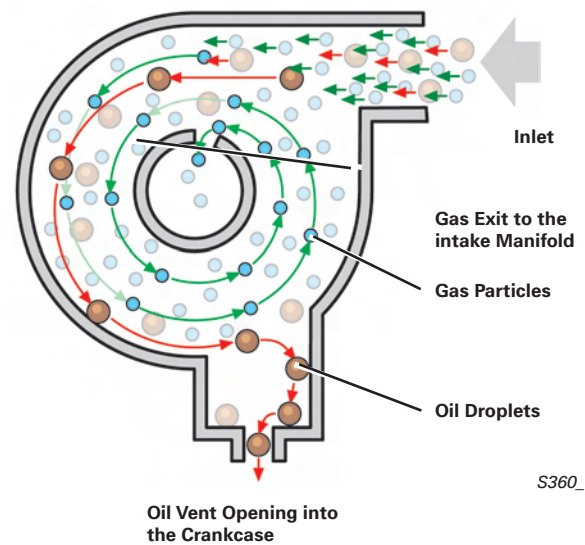
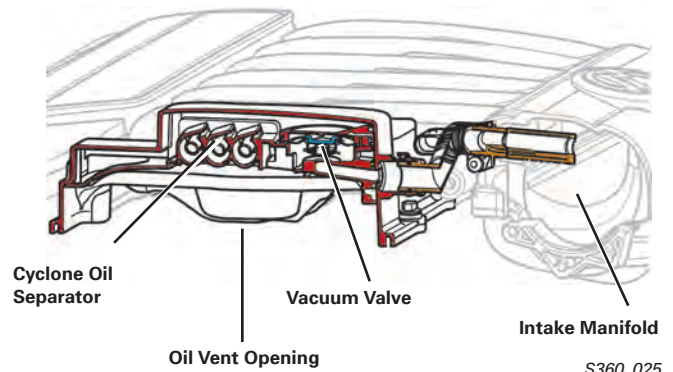

## Crankcase Ventilation Heating

The heating element is installed in the flexible tube from the cyclone oil separator to the intake manifold, and prevents icing of the blow-by gases when the intake air is extremely cold.

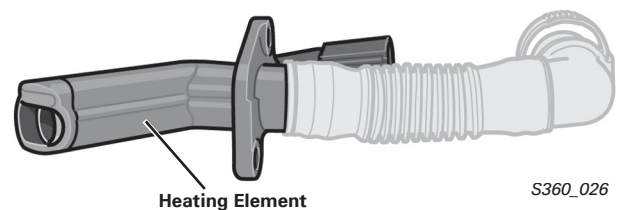

### Note

In the event of a defective pressure regulator valve, the full intake manifold vacuum and internal crankcase pressure are constantly applied to the crankcase ventilation. This causes a large amount of oil to be drawn out of the crankcase, possibly resulting in engine damage.





## The Intake Manifold

Both engines have a single-piece overhead intake manifold made of plastic.

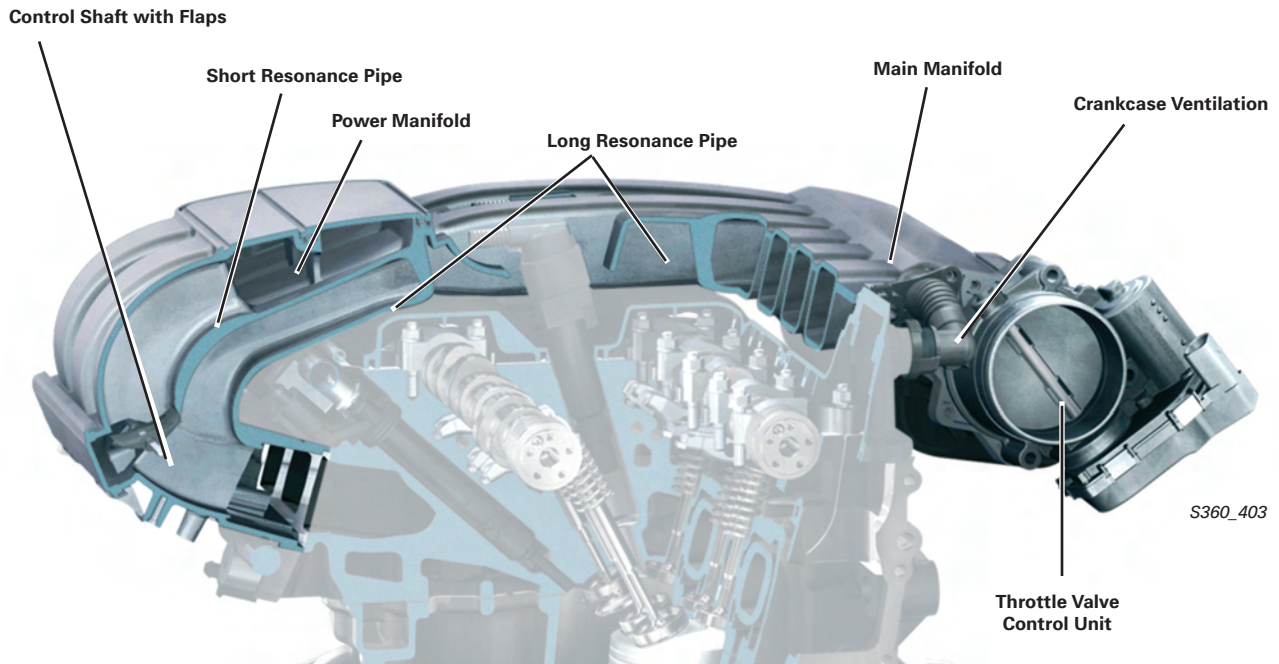

### Design

The variable length intake manifold consists of:

- the main manifold
- two resonance pipes of different length per cylinder
- the control shaft
- the power manifold
- the vacuum tank
- the intake manifold valve

The two resonance pipes differ in length because a long pipe is needed to achieve high torque and a short pipe is needed to achieve high power.

The control shaft opens and closes the connection to the power manifold.

# Engine Mechanics

## The Control Flaps

Switching between the power and torque positions is accomplished by control flaps.

The control flaps are vacuum operated by the Engine Control Module (ECM) J623 through the Intake Manifold Runner Control (IMRC) Valve N316. When current is not applied to the valve, the control flaps are open and are in the power setting.

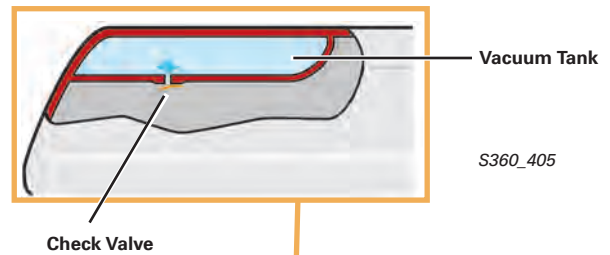
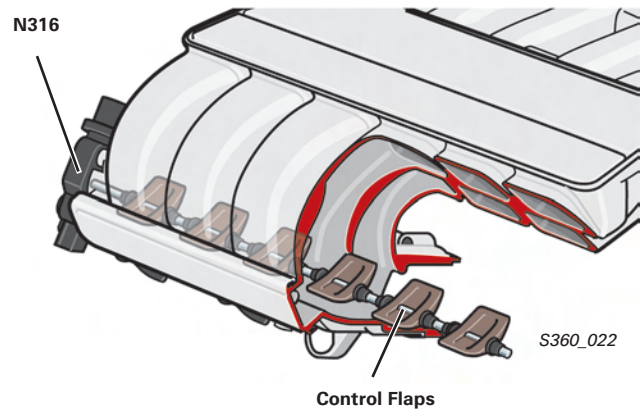

## The Vacuum Tank

A vacuum tank is located within the intake manifold. A vacuum supply is maintained in this vacuum tank and will allow to actuate the control flaps.

The air from the vacuum tank is drawn through a check valve into the primary manifold, so that vacuum can build up in the vacuum tank.

If the check valve is defective, the control flaps cannot be activated.

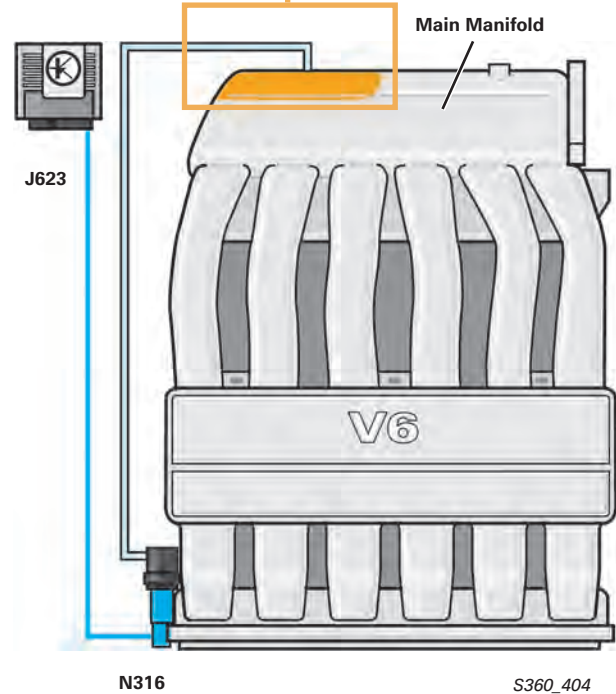

## Function of the Variable Length Intake Manifold

The variable length intake manifold is designed so that a resonance is created between the timing of the valves, the intake pulses and the vibration of the air which produces an increase in pressure in the cylinder and subsequently good charging efficiency in the cylinder.

Power Setting of the Variable Intake Manifold

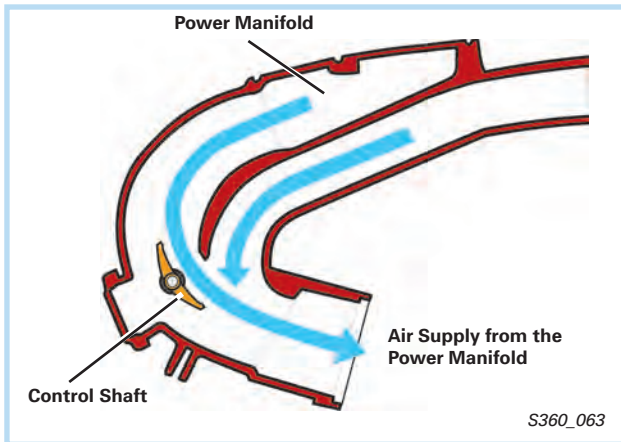

Torque Setting of the Variable Intake Manifold

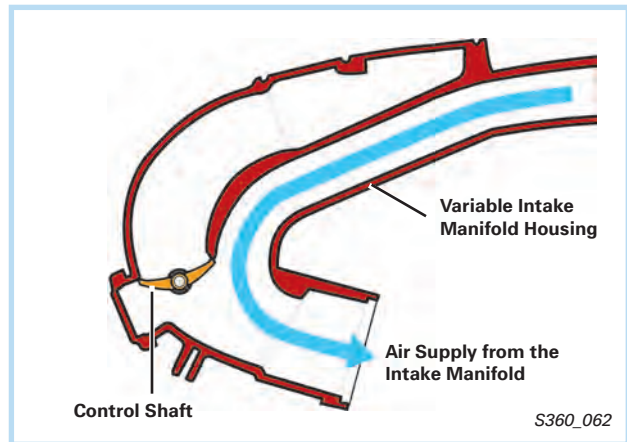

### Engine Speed between 0 and about 1200 rpm

The variable length intake manifold is in the power position. Current is not applied to the intake manifold flap control valve. The vacuum wave generated at the beginning of the intake stroke is reflected at the end of the power collector in the power manifold and returns after a brief time to the intake valve as a pressure wave.

### Engine Speed between about 1200 and 4000 rpm

Current is applied from the ECM to the intake manifold flap control valve. The control flaps are closed and close the power manifold. The cylinders draw air through the torque manifold directly from the main manifold.

### Engine Speed above 4000 rpm

No current is applied to the intake manifold flap control valve. As a result, the intake manifold claps switch back to the power position.

## The Chain Drive

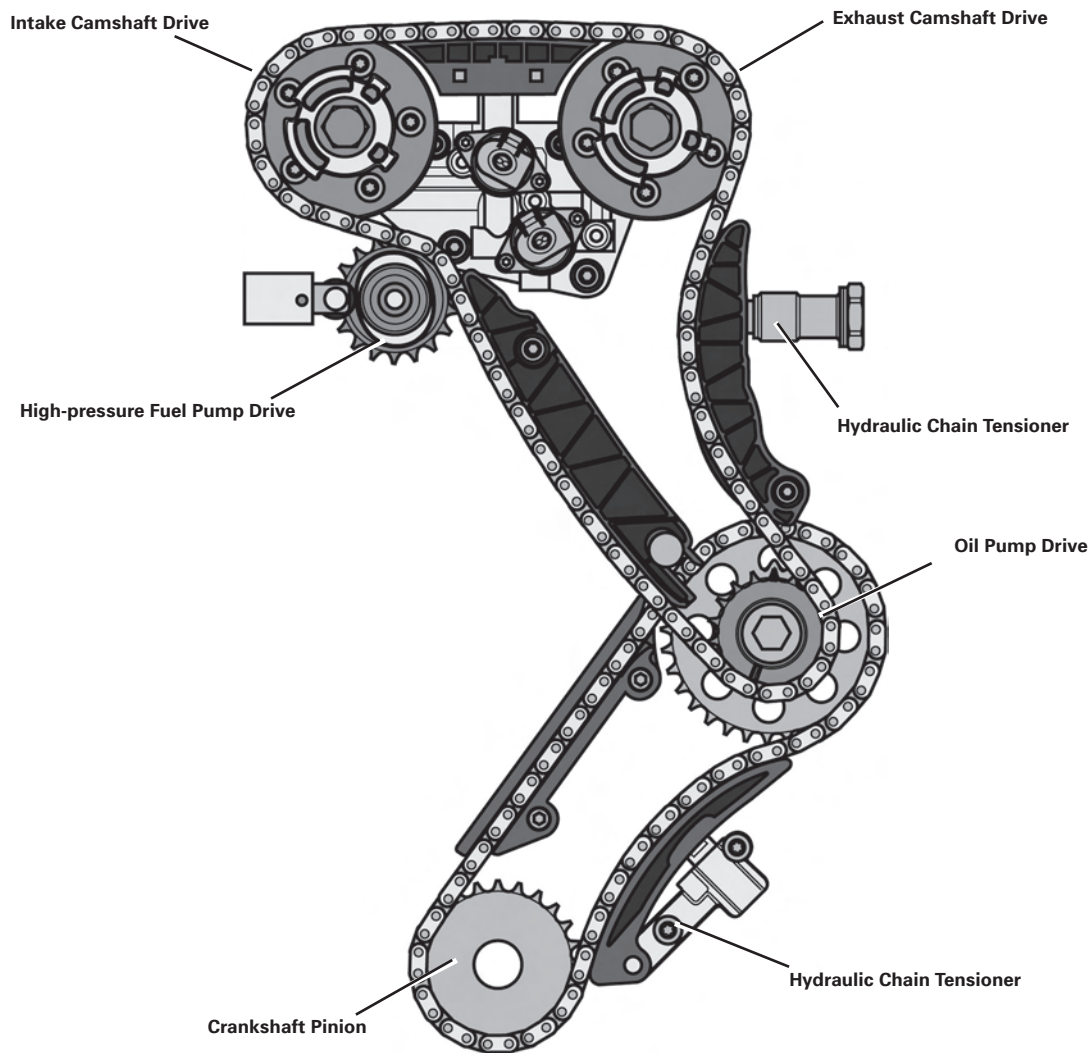

S360\_016

The chain drive is located on the transmission side of the engine. It consists of the primary chain and the camshaft chain.

The primary chain is driven by the crankshaft. It drives the camshaft chain and the oil pump via a sprocket wheel.

The two camshafts and the high-pressure fuel pump are driven by the camshaft chain.

Both chains are kept at the precise tension by hydraulic tensioners.



### Note

Please refer to ElsaWeb when setting the valve timing. There is a new special tool T10332 for locking the high pressure-pump pinion wheel.



## The Ribbed V-belt Drive

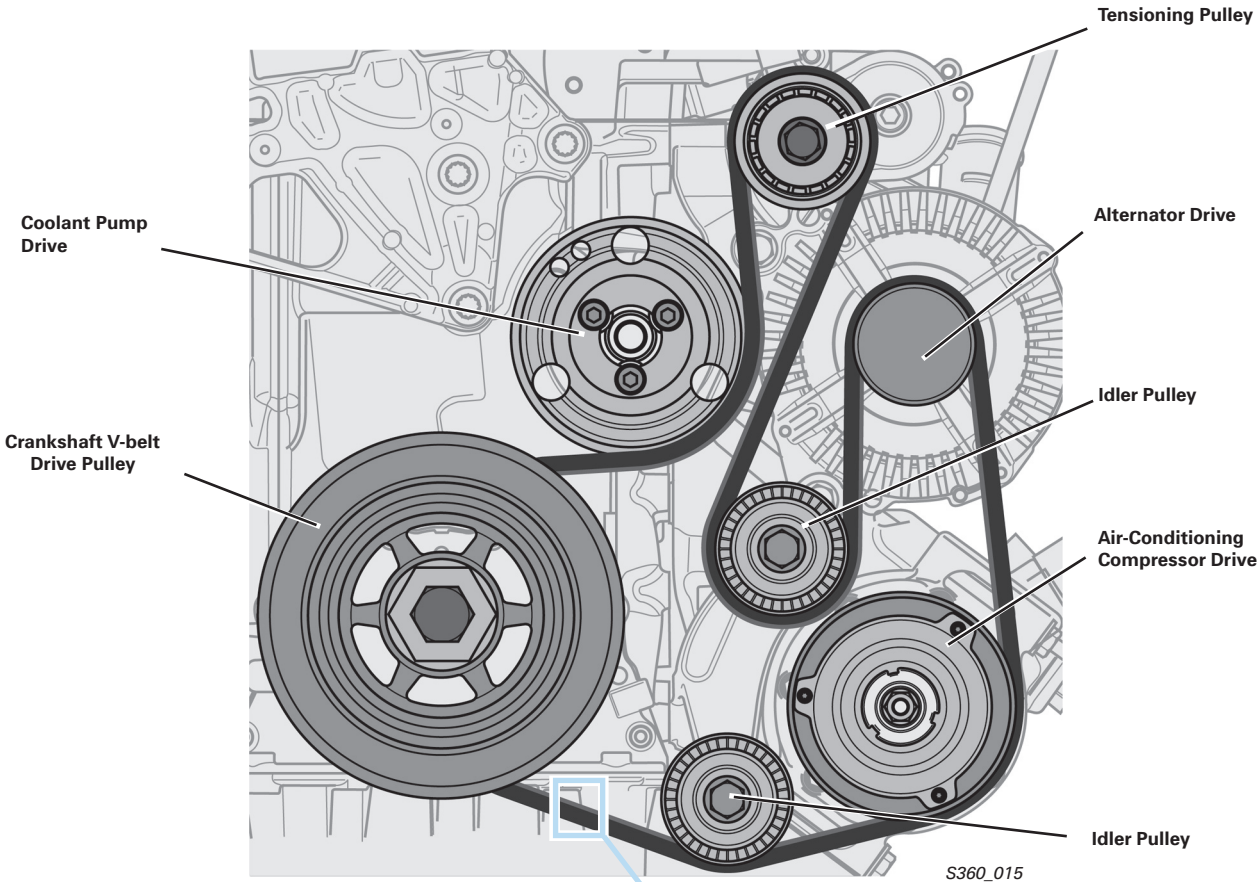

Construction of the Poly-V Drive Belt

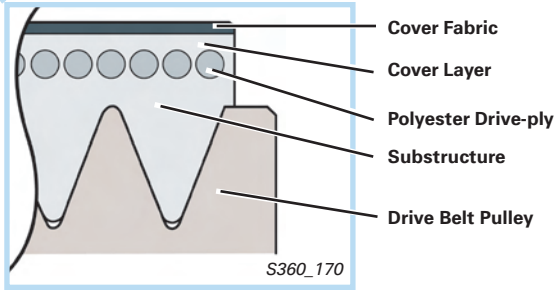

The ribbed V-belt is a single-sided poly-V belt. Even at high speed, it runs quietly and vibration-free. The belt is driven by the crankshaft through the V-belt pulley with vibration damper.

The belt drives the air-conditioning compressor, the alternator and the coolant pump.

The V-belt is always kept at the correct tension by a belt tensioner.

## Oil Circulation

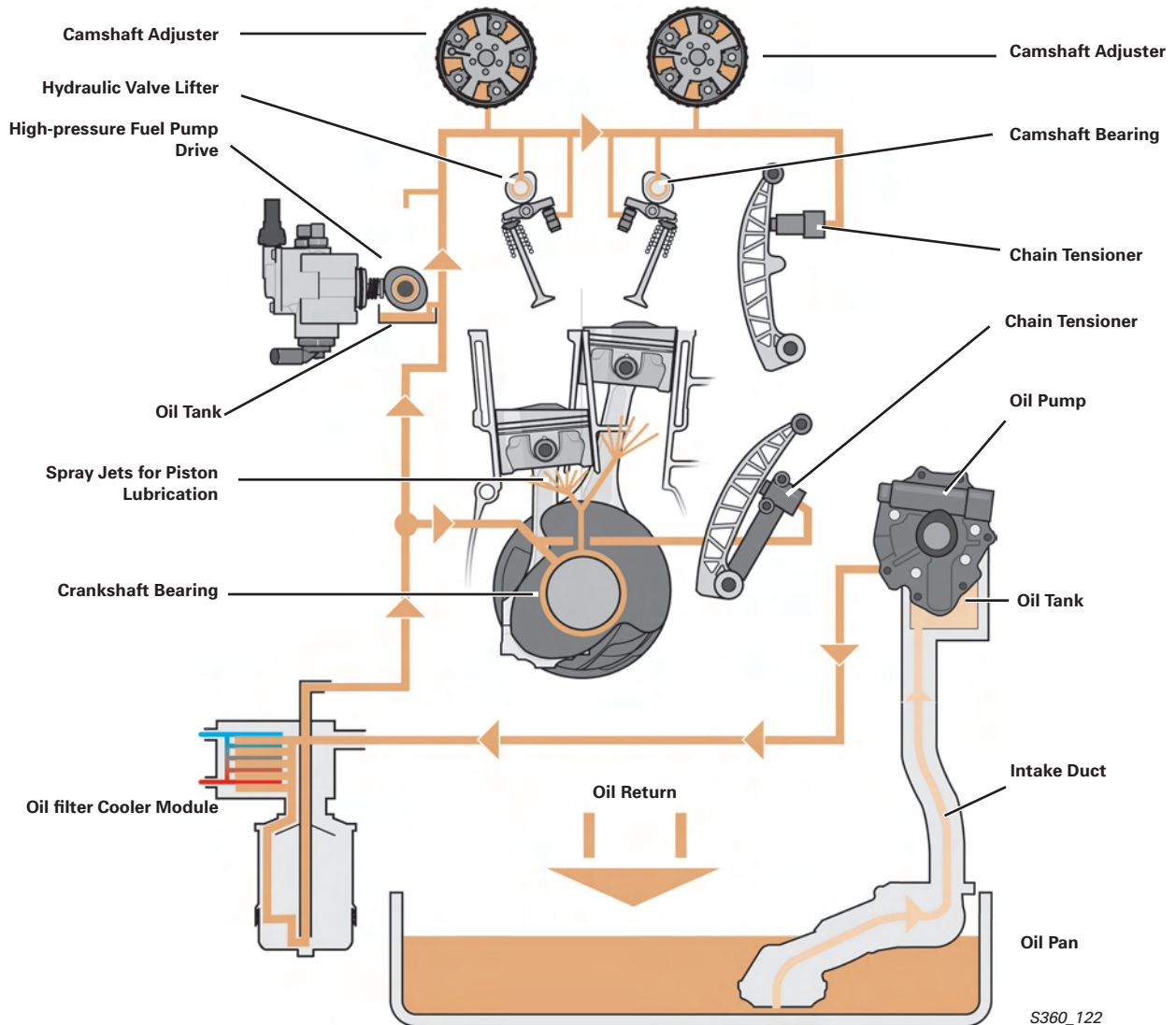

Oil pressure is generated by a self-priming duocentric oil pump. It is installed in the cylinder block and is chain driven.

The particular installation of the oil pump results in a longer path for the oil. With a longer path for the oil to travel, lubrication of engine components on startup can be an issue. For this reason, oil is drawn from an oil tank located behind the oil pump to ensure the initial supply of oil.

The oil pump draws oil from the oil pan and then pumps it to the oil filter-cooler module. In that module, the oil is cleaned and cooled before it is transferred to the lubrication points in the engine.

## The Oil Pump with Oil Tank

The oil tank is formed in the cylinder block by a cavity behind the oil pump. Its volume is approximately 280 ml and remains even after the engine is switched off.

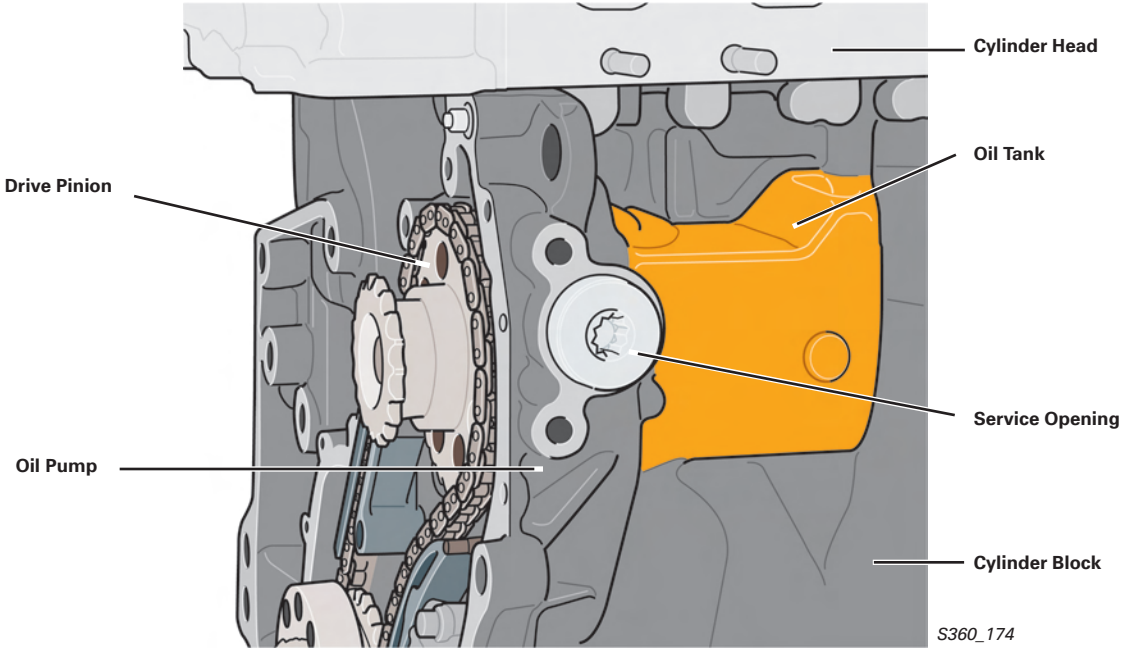

## The Service Opening for the Oil Pump

The service opening provides access to the oil pump excess-pressure piston with the engine installed. After removing the cover bolt and a second internal bolt, the oil pump pressure piston can be removed and its condition can be inspected without having to remove the drive chain.

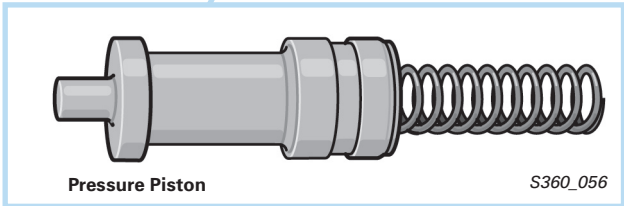
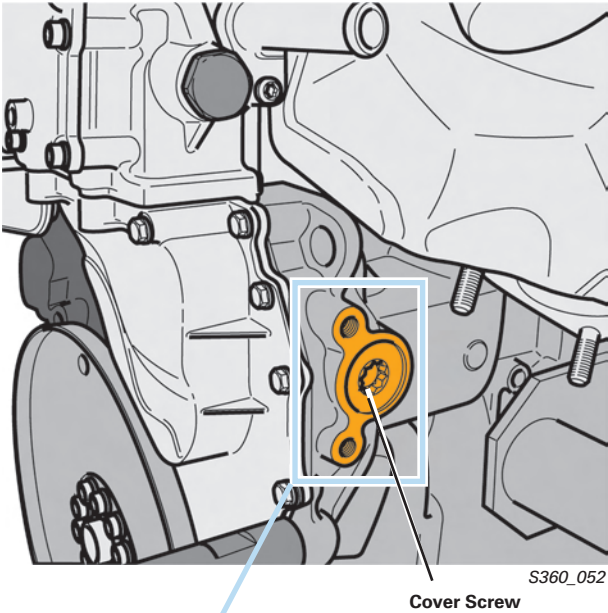

## The Oil Filter Cooler Module

The oil filter cooler module is an assembly made of the oil filter, oil cooler, check valve and filter bypass valve.

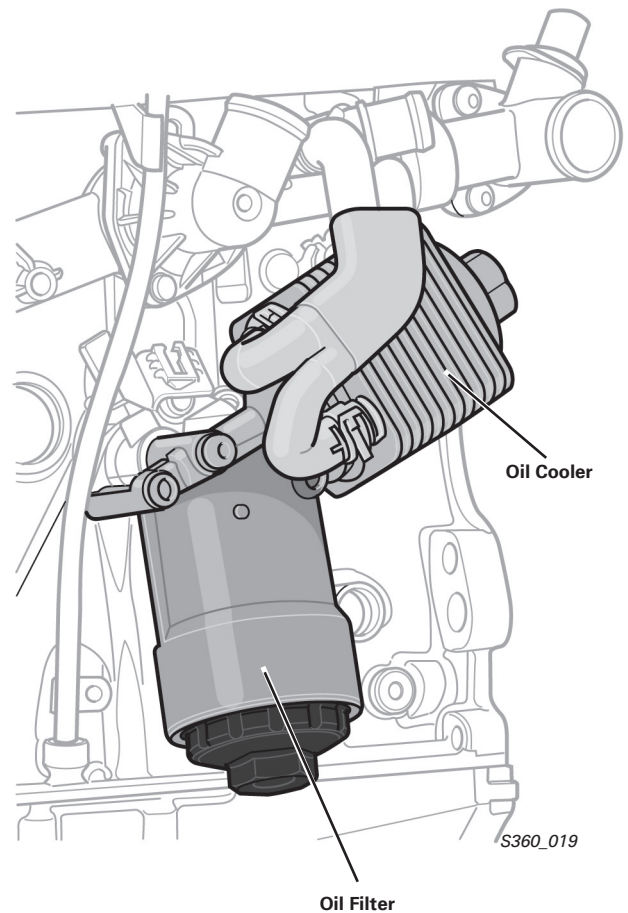

## The Oil Return

The returning oil is directed through three return ducts in the cylinder head into a central oil return duct in the cylinder block.

The oil then flows into the oil pan under the oil level. In addition to the central oil return, oil is returned to the oil pan from the front of the engine through the timing chain housing.

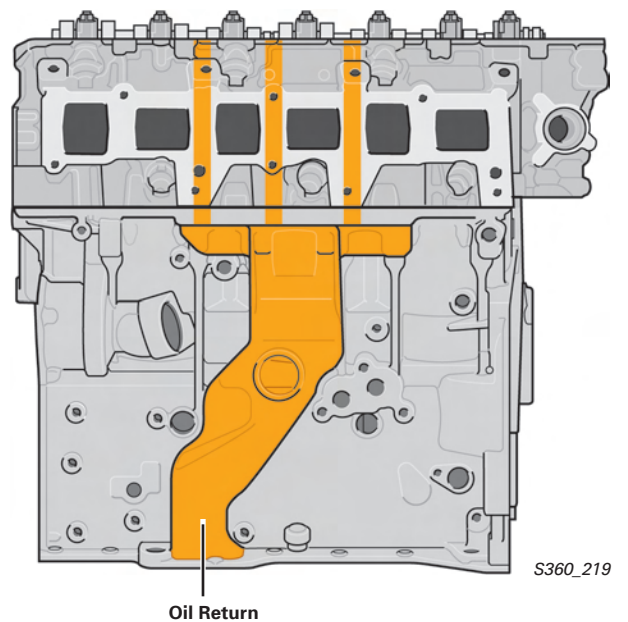

## Coolant Circulation

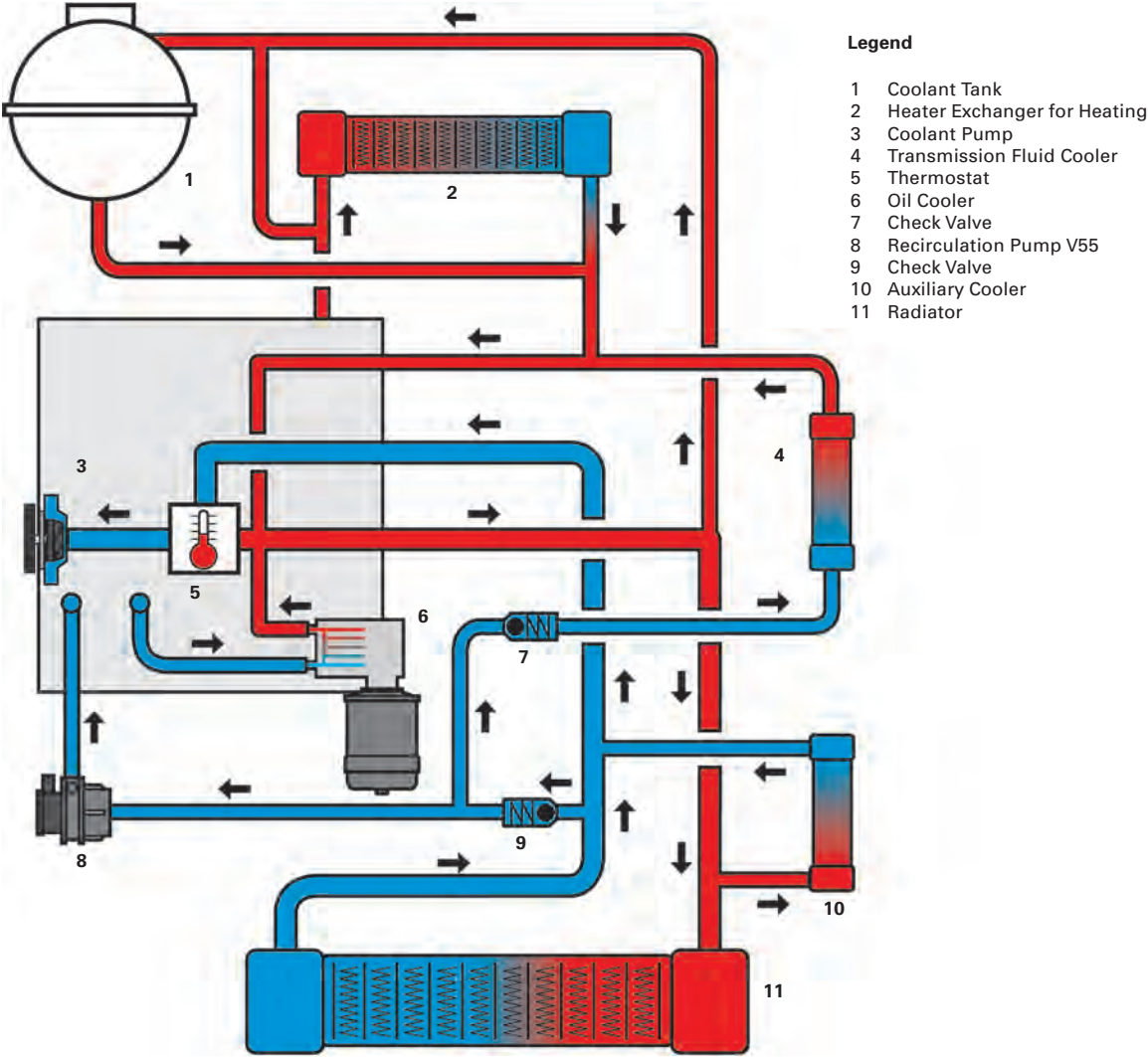

S360\_213

The coolant is circulated by the mechanical coolant pump. The pump is driven by the V-belt.

There are 9 liters (2.4 gallons) of coolant in the cooling system. The total amount of coolant has been reduced by 2 liters in comparison to the 3.2L injection engine. This allows the engine to more quickly reach its operating temperature.

Coolant circulation is controlled by the expansion thermostat.

Depending on the vehicle, there may be an auxiliary cooler in the coolant circuit.

The check valves are included in the coolant circuit in order to prevent any coolant return flow.



# Engine Mechanics

## The Recirculation Pump V55

The Recirculation Pump is an electrical pump. It is integrated into the engine coolant circuit and is actuated by the ECM based on a characteristic map.

After the engine has been turned off, the Recirculation Pump is switched on depending on coolant temperature.

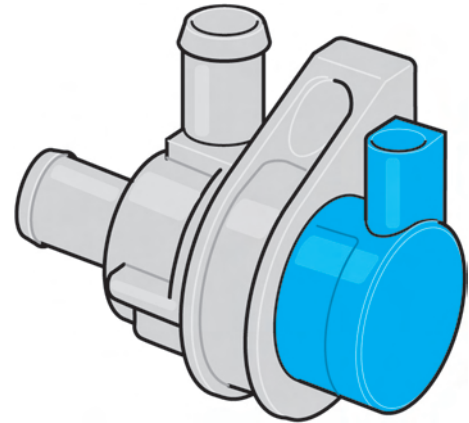

S360\_169

## The Coolant Fan

The V6 FSI engine has two electric Coolant Fans. The Coolant Fans are activated as needed by the ECM.

The Engine Control Module (ECM) J623 signals the need for radiator cooling to the Coolant Fan Control (FC) Module J293.

Depending on the need, the Coolant Fan Control (FC) Module J293 then supplies current to one or both of the fans. Current is supplied to the Cooling Fan Control (FC) Module J293 by the Motronic Engine Control Module (ECM) Power Supply Relay J271 and by the Vehicle Electrical System Control Module J519.

The fans can also be switched on by the Coolant Fan Control (FC) Module after the engine has been turned off.

In order to turn on the fans when the engine has been turned off, the Coolant Fan Control (FC) Module has a connection to terminal 30.

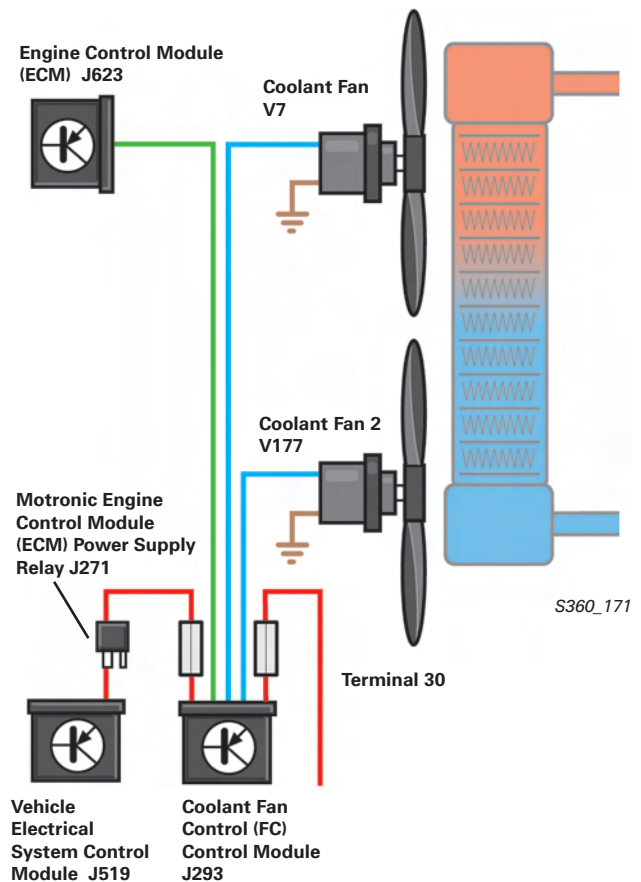

S360\_171

## The Exhaust System

### 3.2-liter V6 FSI Engine

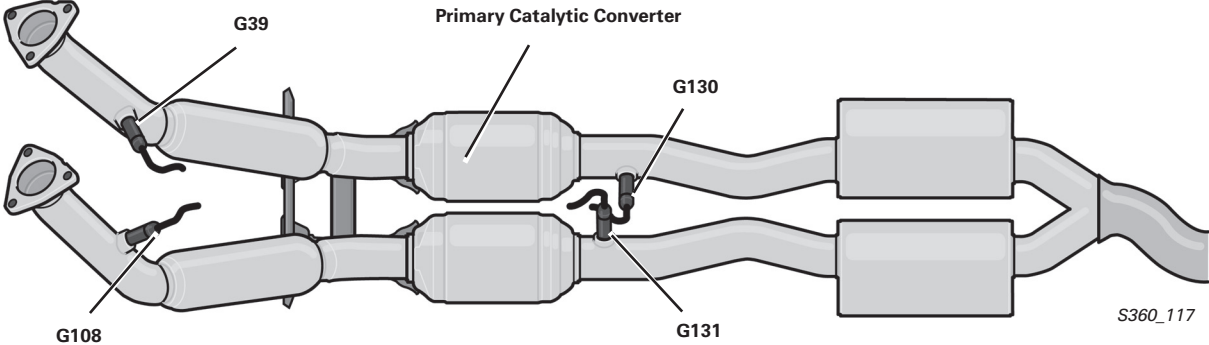

The exhaust system for the 3.2L engine has a primary catalytic converter for each cylinder bank with a ceramic base.

Exhaust gas quality is monitored by two oxygen sensors upstream and downstream of the catalytic converters.

### 3.6-liter V6 FSI engine

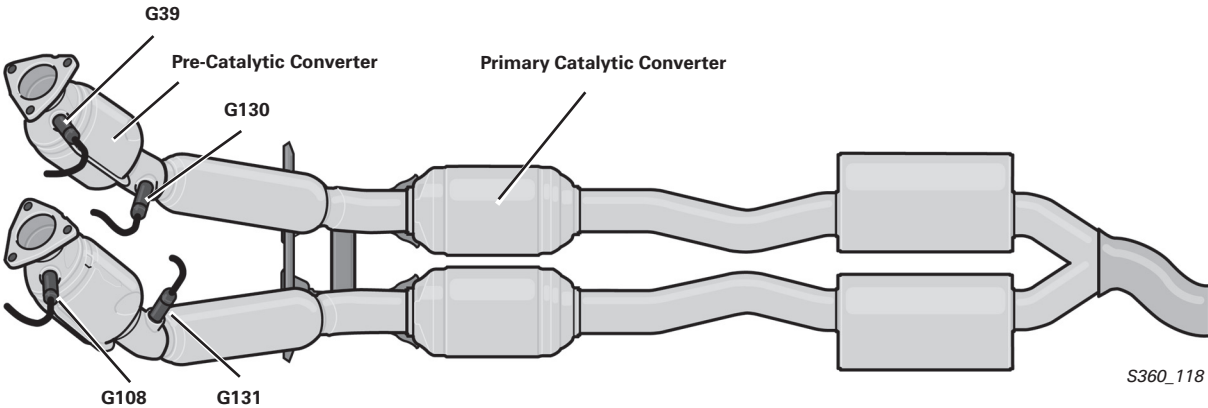

The exhaust system for the 3.6L FSI engine is equipped with two pre-catalytic converters and 2 main catalytic converters.

Exhaust gas quality is monitored by two oxygen sensors upstream of the pre-catalytic converters and two oxygen sensors downstream of the pre-catalytic converters.

The exhaust system complies with Low Emission Vehicle (LEV2) emission standards.

## FSI Technology

### Contributing Factors

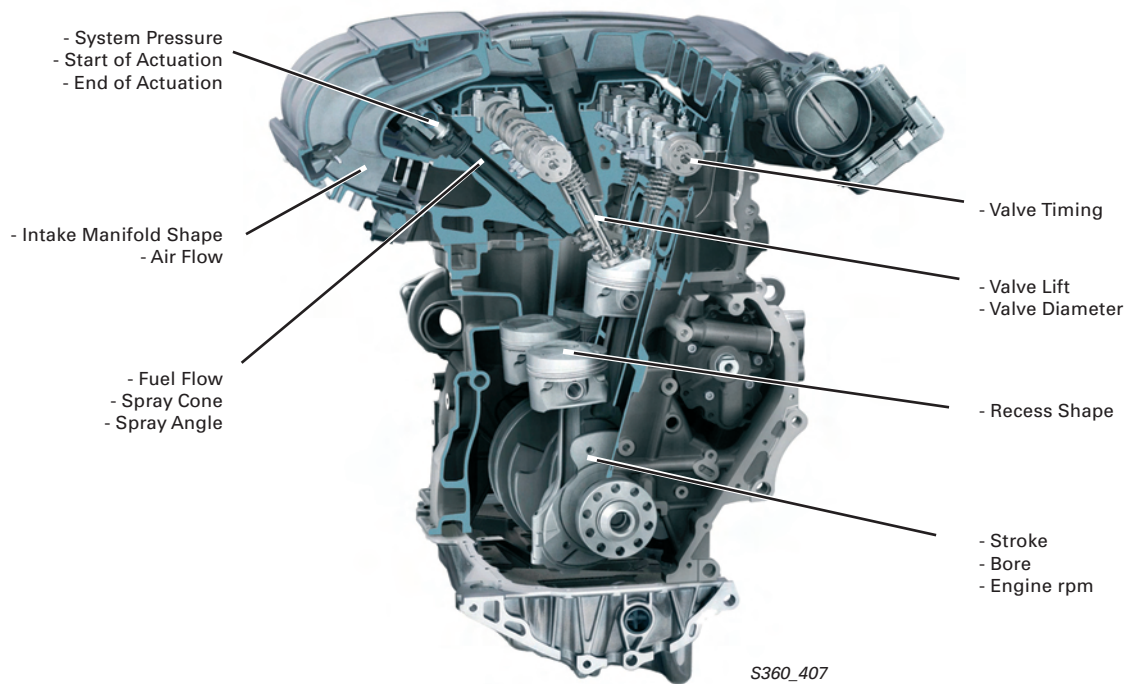

Direct gasoline injection requires precise timing of the combustion process.

The factors affecting the combustion process are:

- Cylinder bore and stroke
- Shape of the recess in the piston surface
- Valve diameter and lift
- Valve timing
- Geometry on the intake ports
- Volumetric efficiency of the fresh air supplied
- Fuel injector characteristics (spray cone, spray angle, flow amount, system pressure and timing)
- Engine rpm

An essential part in the optimization of the combustion performance is the study of airflow characteristics in the combustion chamber. The mixture formation is substantially affected by the flow characteristics of the intake air and the injected fuel.

In order to determine the optimal airflow characteristics and as a result define the optimal piston shape for both banks of cylinders, Doppler Global Velocimetry was used. This procedure makes it possible to study airflow characteristics and mixture formation while the engine is running.

With the help of this procedure and by modifying the characteristics of the fuel injectors it was possible to equalize and match airflow velocities and mixture formation in the combustion chambers for both cylinder banks.



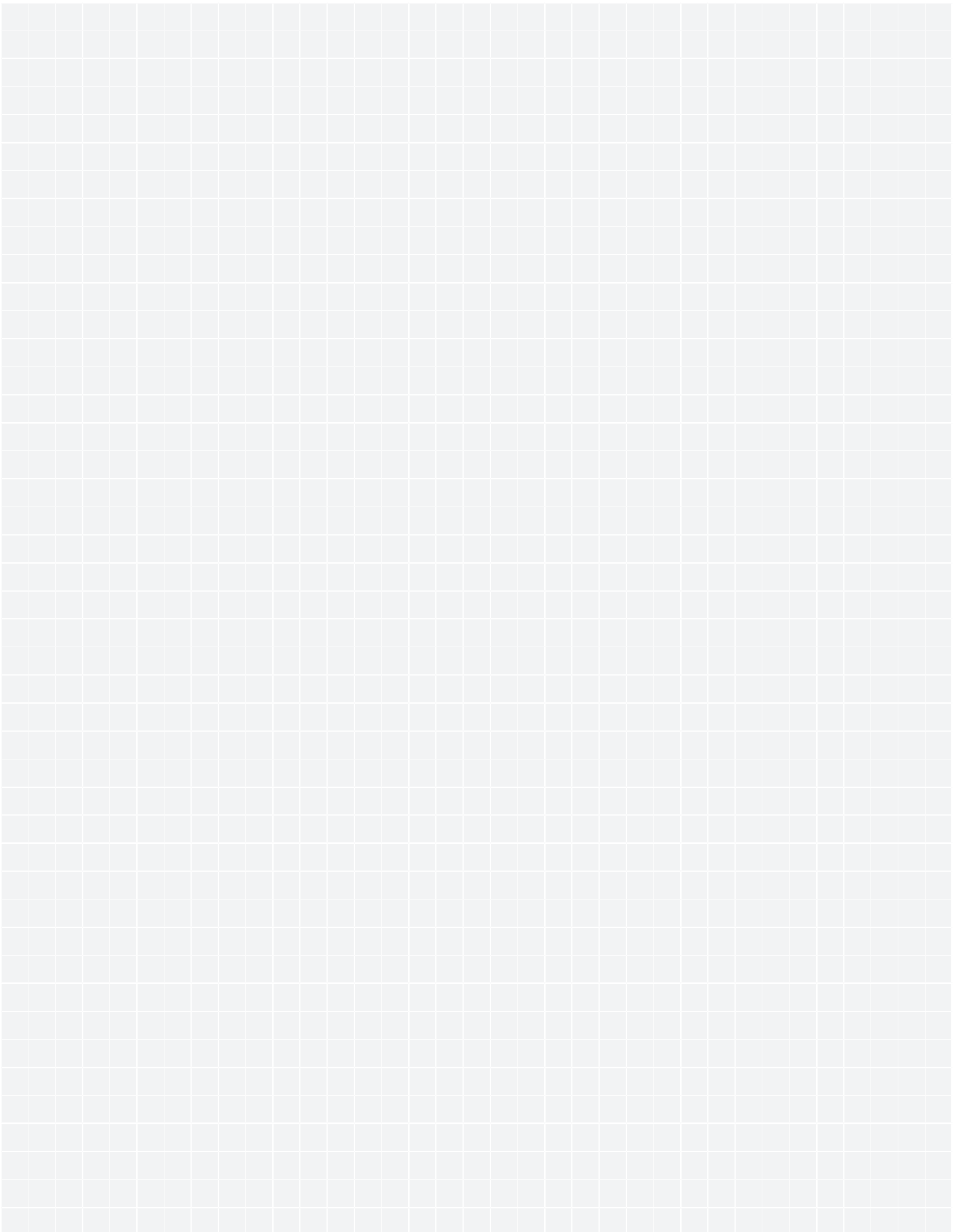

## The Fuel System

- G6 Transfer Fuel Pump (FP)
- G247 Fuel Pressure Sensor
- G410 Low Fuel Pressure Sensor
- J538 Fuel Pump (FP) Control Module
- J623 Engine Control Module (ECM)
- N276 Fuel Pressure Regulator Valve

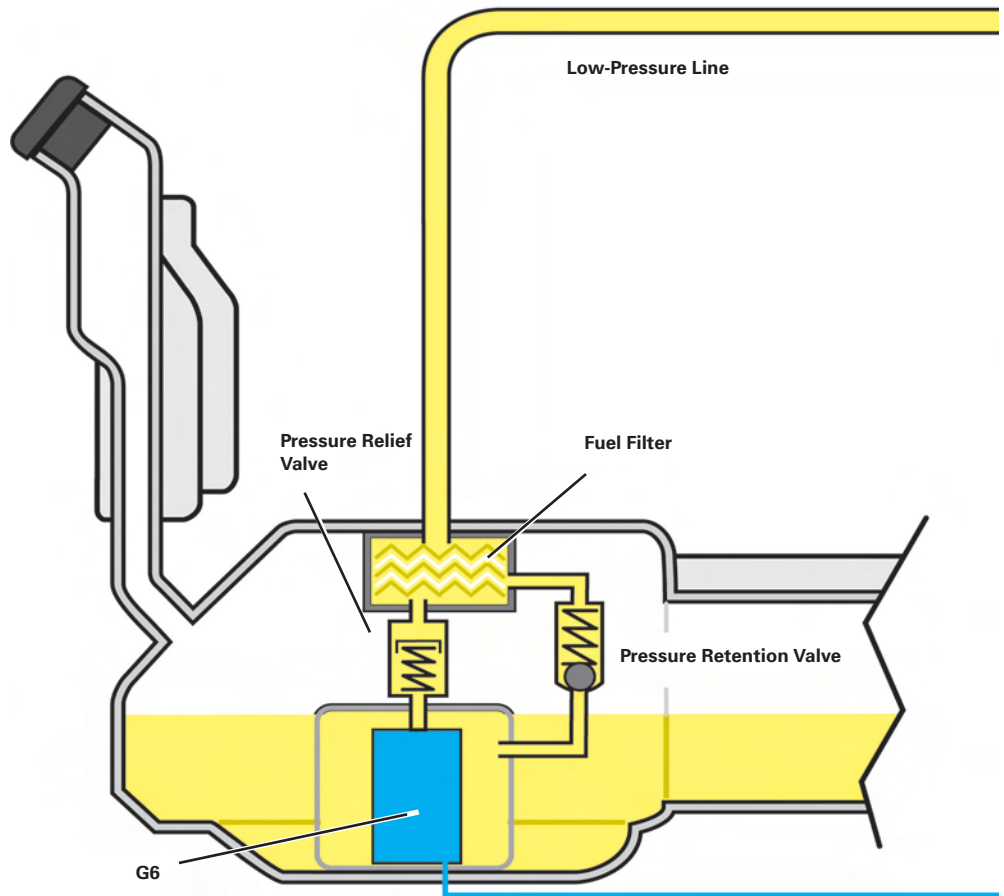

## The Low-Pressure Fuel System

The low-pressure system transfers fuel from the fuel tank. The transfer fuel pump is activated by the ECM through the Fuel Pump Control Module depending on the requirements at a working pressure between 2 and 5 bars.

### Operation

The signal from the Low Fuel Pressure Sensor G410 informs constantly the ECM of the current fuel pressure.

The ECM compares the current pressure to the required fuel pressure. If the current fuel pressure is not adequate to meet the fuel needs, the ECM activates the Fuel Pump (FP) Control Module J538. This control module then activates the transfer fuel pump, which increases the working pressure. When the fuel requirement drops again, the working pressure at the pump drops accordingly.

The pressure retention valve maintains the fuel pressure when the engine is switched off. If the fuel line is ruptured in an accident, the pressure retention valve prevents fuel from escaping.

The pressure relief valve opens at a pressure of 93 psi (6.4 bar) and thus prevents excessive fuel pressure in the low-pressure line.

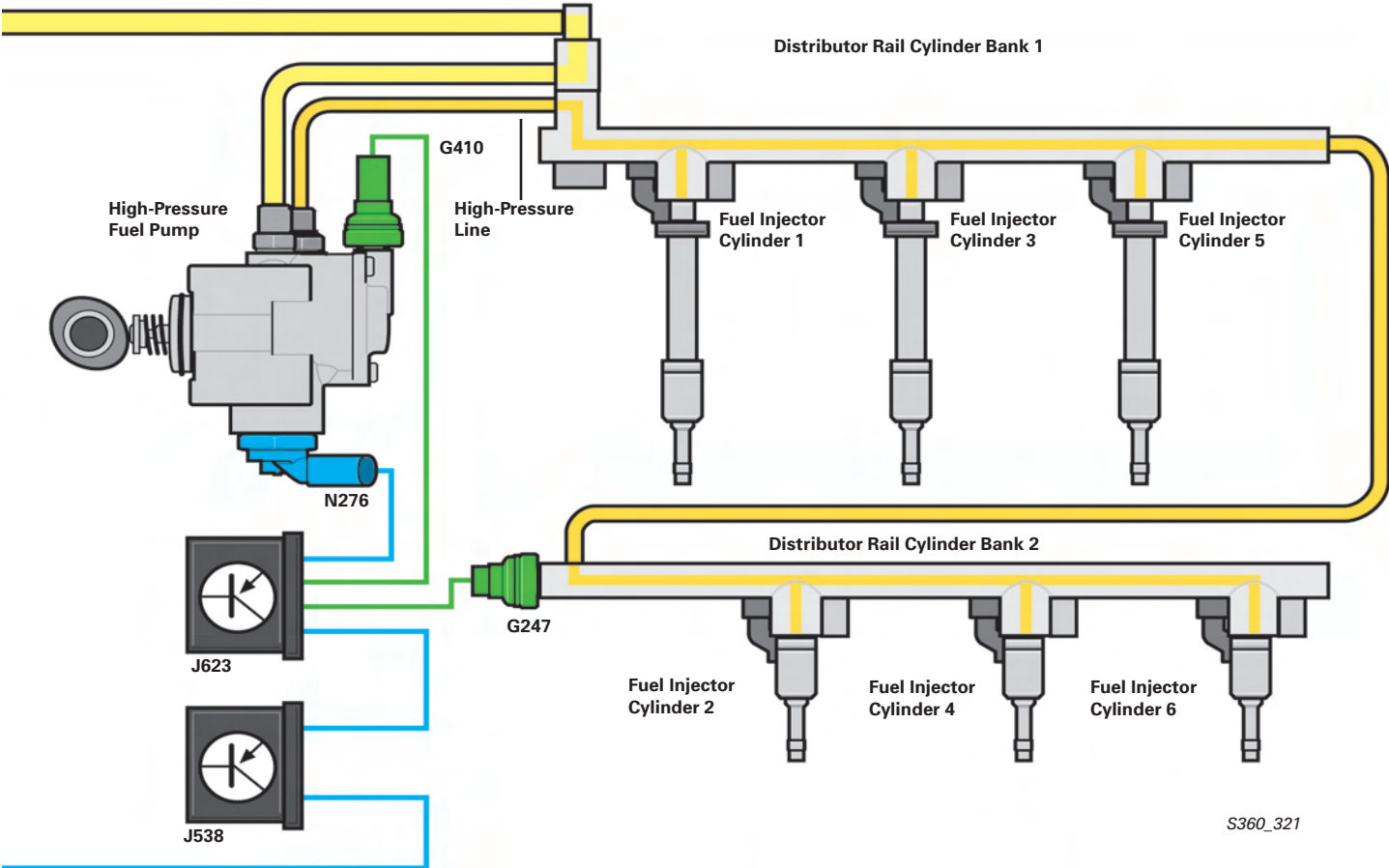

## The High-Pressure Fuel System

### The Fuel Pressure Sensor G247

The Fuel Pressure Sensor G247 is installed in the fuel distributor of the cylinder bank 2 and informs the ECM of current pressure in the high-pressure fuel system.

### The Fuel Pressure Regulator Valve N276

The Fuel Pressure Regulator Valve N276 is threaded into the high-pressure fuel pump and regulates the pressure in the high-pressure fuel system according to the signal from the ECM.

### The pressure relief valve

The pressure relief valve is located on the fuel distributor of the cylinder bank 1.

The valve opens a connection to the low-pressure fuel system when the fuel pressure in the high-pressure fuel system is over 1,740 psi (120 bars).

# Engine Mechanics

## The High-Pressure Fuel Pump

The High-Pressure Fuel Pump is located on the cylinder head and is a piston pump. It is driven by the camshaft and generates a fuel pressure of 1,595 psi (110 bars).

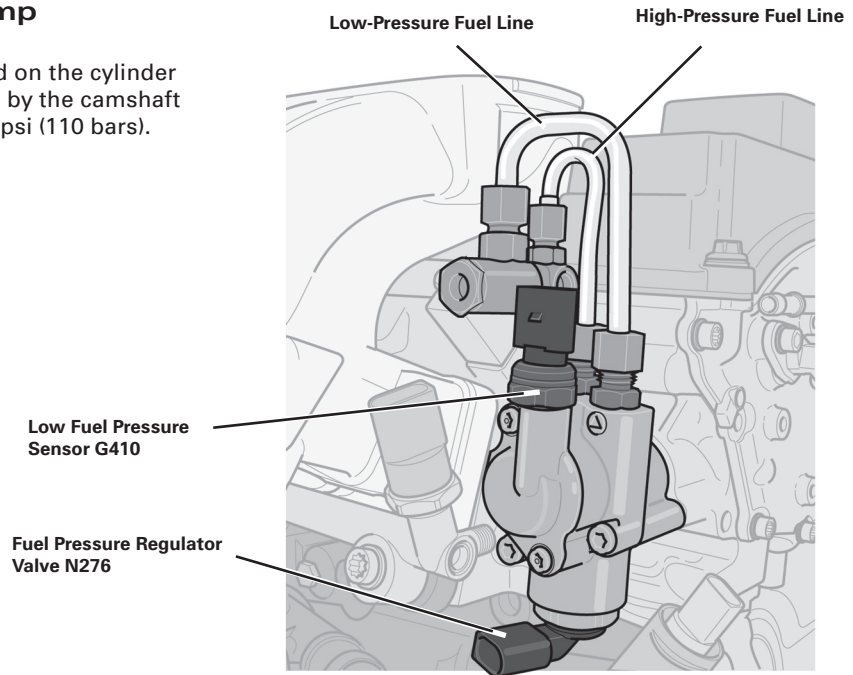

S360\_123

## The High-Pressure Fuel Pump Drive

The High-Pressure Fuel Pump is driven by a pinion gear with dual cam.

The dual cam actuates the pump piston through a roller. The pump piston generates the high pressure in the pump.

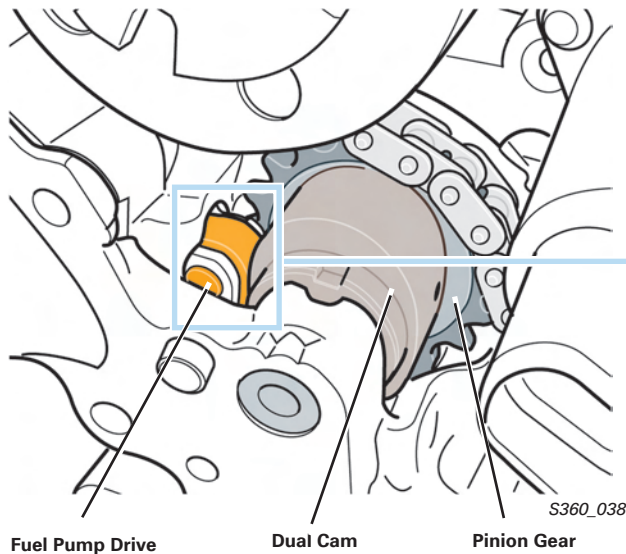

S360\_038

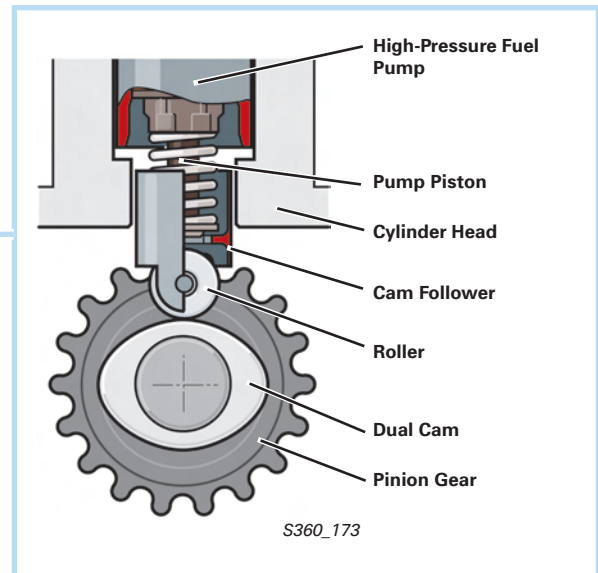

S360\_173

### Note



In order to install the camshaft roller chain, the High-Pressure Fuel Pump pinion must be locked with special tool T10332. Please refer to ElsaWeb for the latest repair information.

## Fuel Injector Characteristics

Since the fuel injectors are inserted from the same side for both banks of cylinders, the piston recess must be shaped differently. This is necessary because the fuel injectors and the intake valves for both cylinder banks are positioned at different angles. The shape and orientation of the fuel injection play an important role along with the quantity of fuel injected and the length of injection.

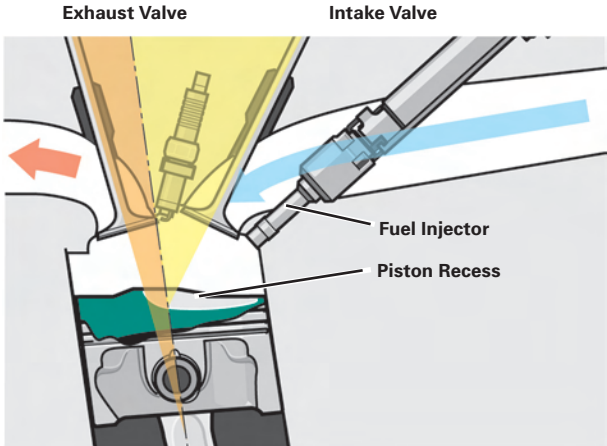

Valve Angle Cylinder 1, 3, 5

S360\_252

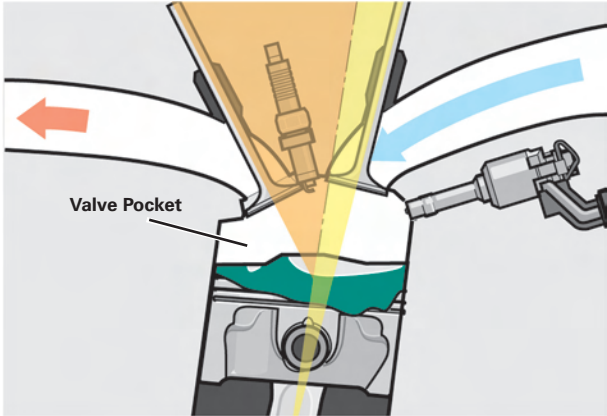

Valve Angle Cylinder 2, 4, 6

S360\_251

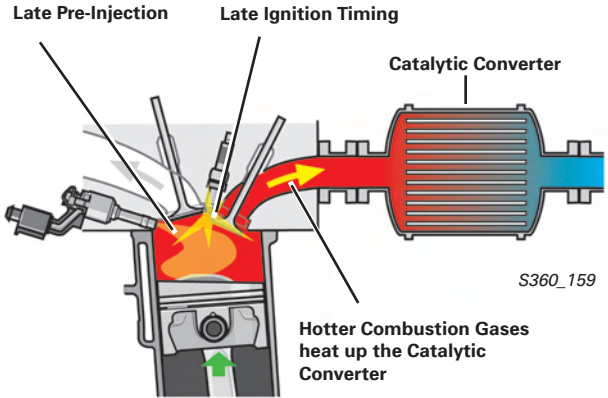

S360\_159

## The Homogenous Split Catalytic Converter Heating Process

The purpose of the Homogenous Split Catalytic Converter Heating Process is to bring quickly the catalytic converters to operating temperature after a cold start.

To achieve this, the fuel is injected twice during one combustion cycle. The first injection takes place in the induction stroke. This achieves an even distribution of the fuel-air mixture.

In the second injection, a small amount of fuel is additionally injected shortly before ignition Top Dead Center (TDC). The late injection increases exhaust gas temperature. The hot exhaust gas heats up the catalytic converter so that it reaches operating temperature more quickly.

# Engine Management

## System Overview

### Sensors

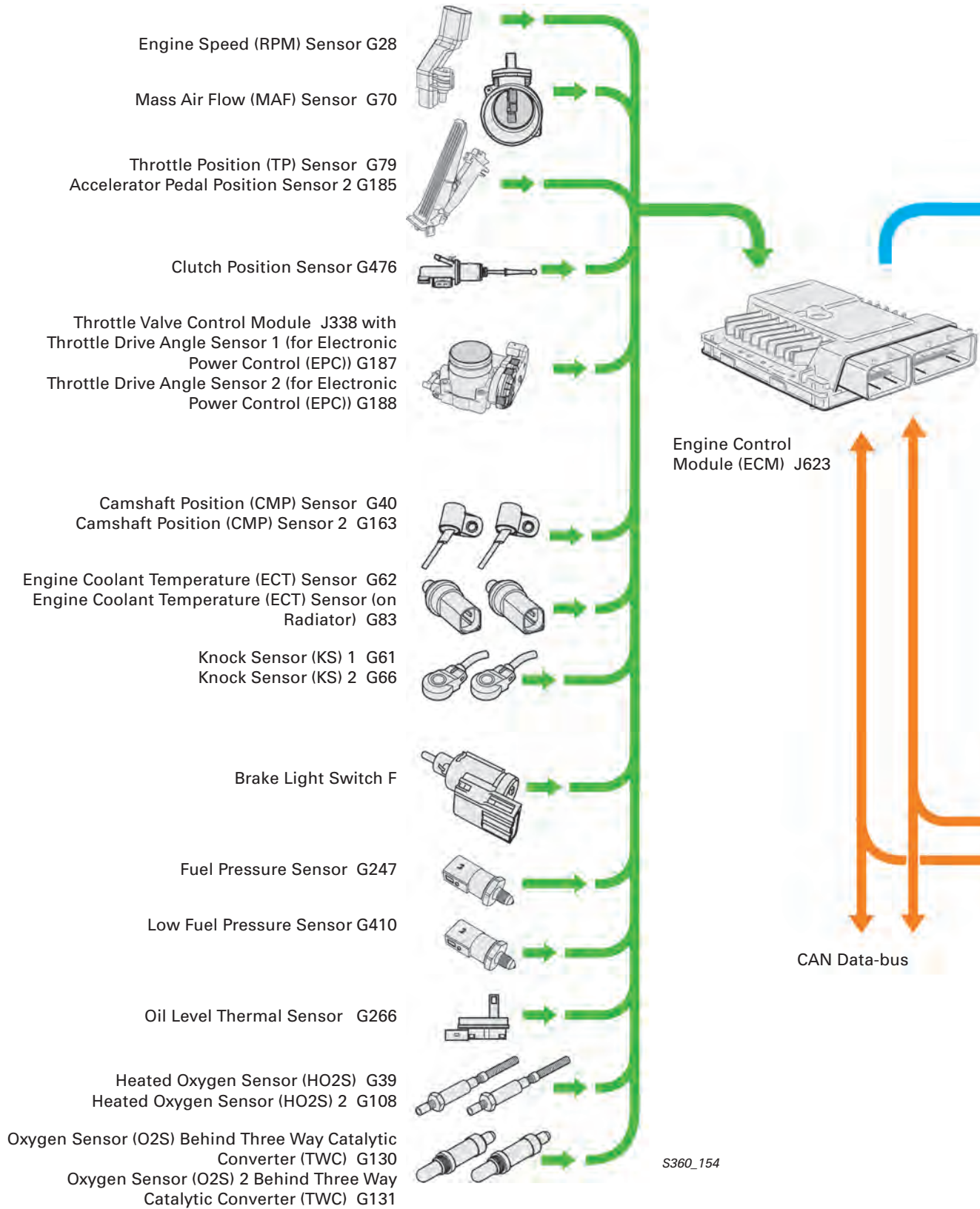



## Actuators

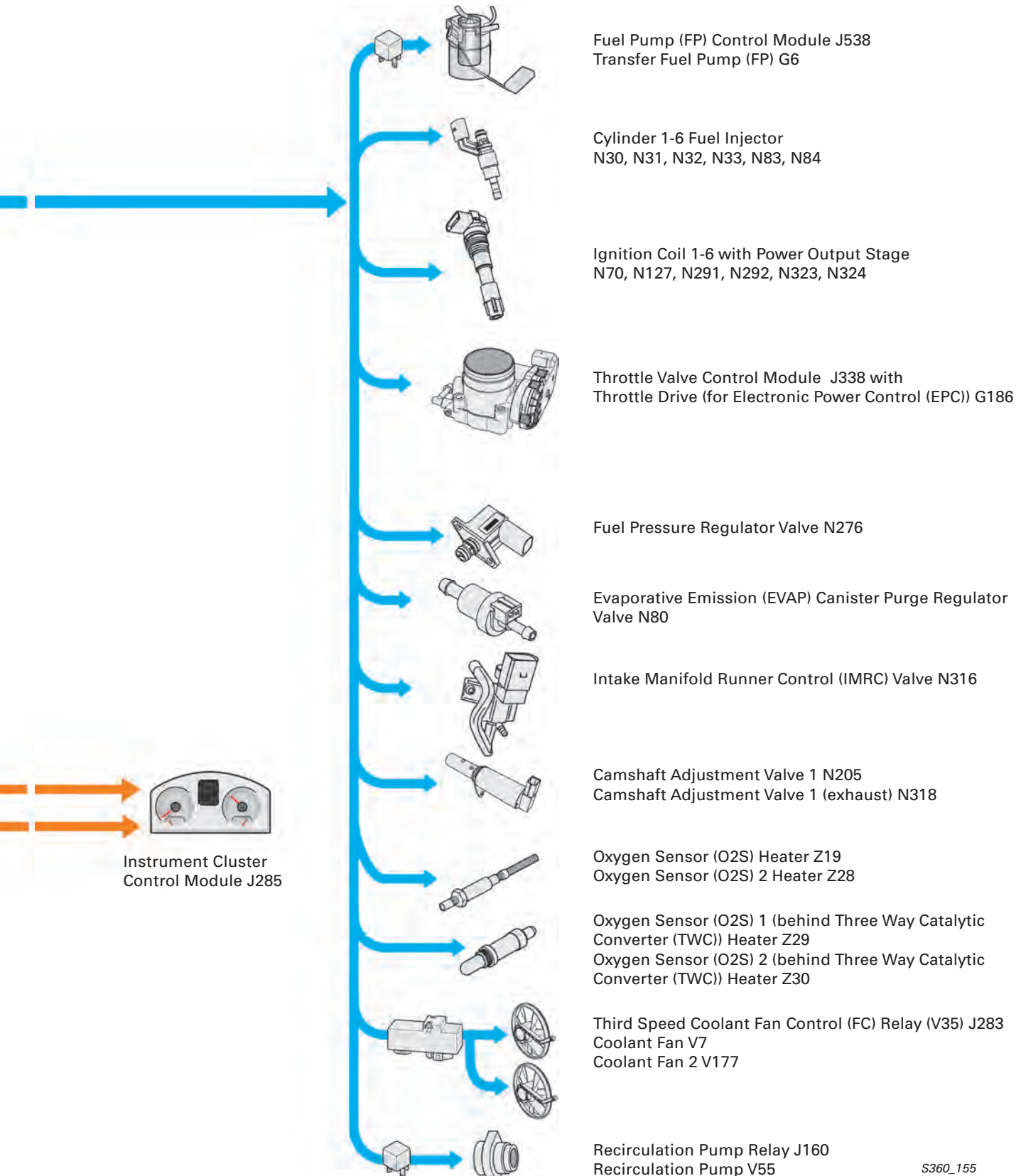

S360\_155

## Sensors

### Engine Speed (RPM) Sensor G28

The Engine Speed Sensor is threaded into the side of the cylinder block. It scans the sensor wheel on the crankshaft.

#### Signal Utilization

The engine speed and the exact position of the crankshaft relative to the camshaft are determined by the engine speed sensor. Using this information, the injection quantity and the start of injection are calculated.

#### Effects of Signal Failure

In case of signal failure, the engine is switched off and cannot be restarted.

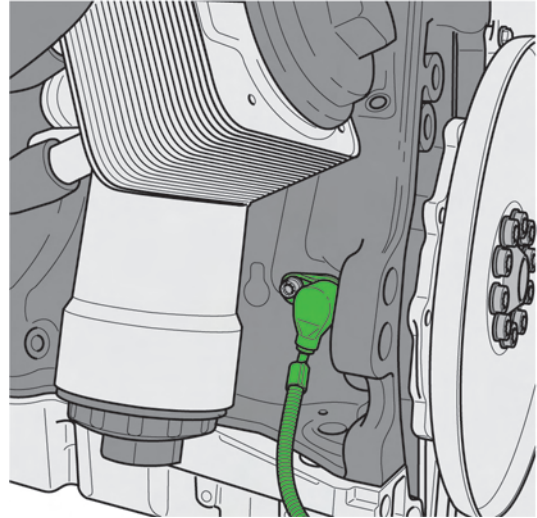

S360\_111



## Mass Airflow Sensor G70

The 6th generation hot film mass airflow sensor (HFM6) is used in the 3.2L and the 3.6L FSI engine. It is located in the intake manifold and operates based on a thermal measurement principle, as did its predecessor.

### Characteristics

- Micromechanical sensor element with reverse current detection
- Signal processing with temperature compensation
- High measurement accuracy
- High sensor stability

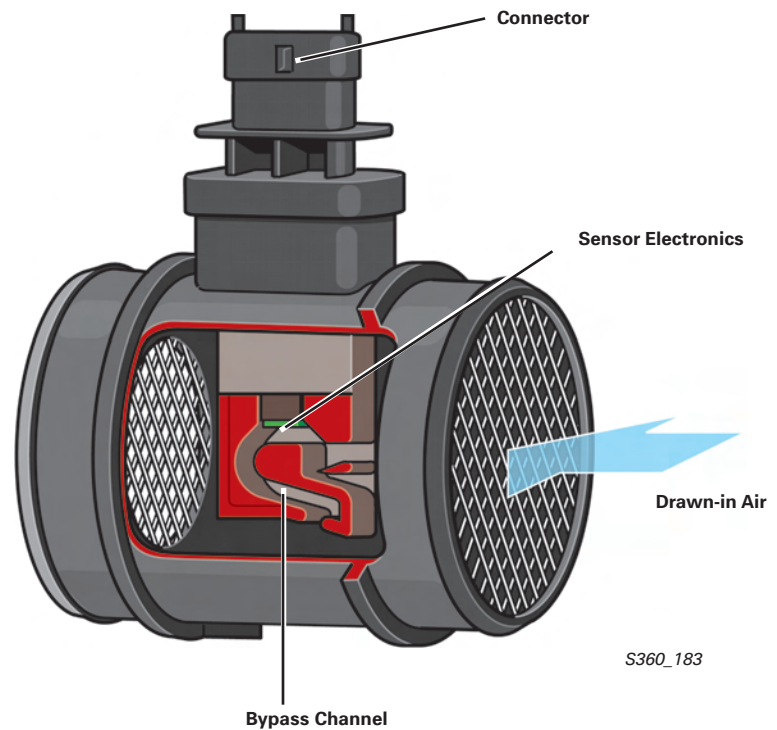

# Engine Management

## Operation

The sensor element for the Mass Airflow Sensor protrudes into the airstream of the air drawn in by the engine. Some of the air flows through the bypass duct of the mass air flow sensor.

The electronic sensor system is located in the bypass duct. A heating resistor and two temperature sensors are located in the electronic sensor system.

The two temperature sensors detect the direction of airflow:

- The intake air passes first over temperature sensor 1
- The air returning from the closed valves passes first over temperature sensor 2

Using the heating resistor, the ECM can draw conclusions about the oxygen content of the intake air.

## Signal Utilization

The signal from the mass airflow sensor is used in the ECM to calculate the volumetric efficiency. Based on the volumetric efficiency, and taking into consideration the lambda value and ignition timing, the control module calculates the engine torque.

## Effects of Signal Failure

If the mass airflow sensor fails, the engine management system calculates a substitute value.

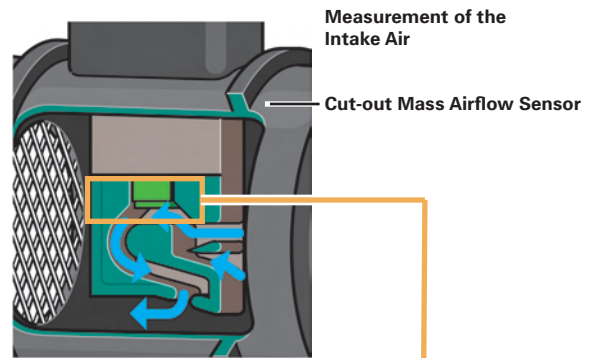

S360\_178

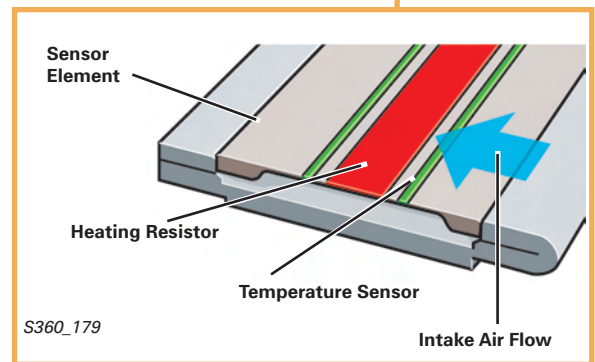

S360\_179

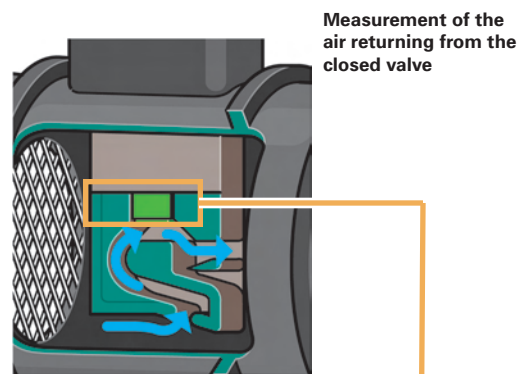

S360\_180

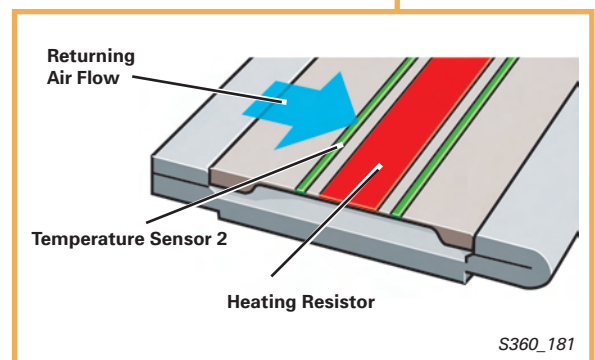

S360\_181

## The Throttle Position (TP) Sensor G79 and the Accelerator Pedal Position Sensor 2 G185

The two throttle position sensors are part of the accelerator pedal module and are contact-free sensors. The ECM detects the driver's request from these sensor signals.

### Signal Utilization

The ECM uses the signals from the Throttle Position Sensor to calculate the fuel injection volume.

### Effects of a Signal Failure

If one or both sensors fails, a DTC is set and memory and the EPC light is switched on. Comfort functions such as cruise control or engine drag torque control are switched off.

## Clutch Position Sensor G476

The Clutch Position Sensor is a mechanically actuated switch located on the clutch pedal. It is only required on vehicles with manual transmission.

### Signal Utilization

The signal is used to control the cruise control and to control the ignition timing and quantity of fuel when shifting.

### Effects of a Signal Failure

The cruise control cannot be turned on. It also results in driveability problems, such as engine jerking and increased RPM when shifting.

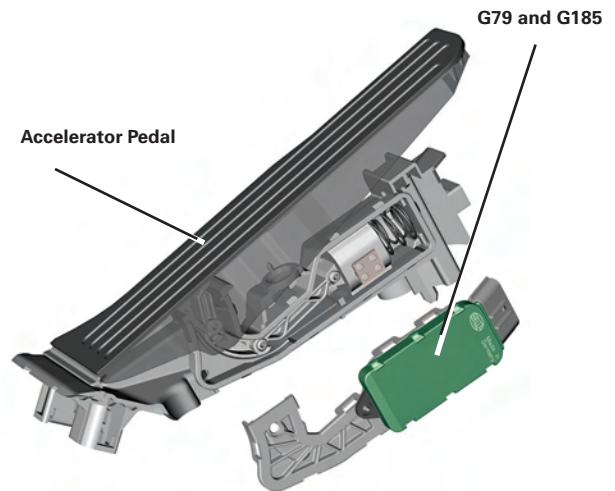

S360\_150

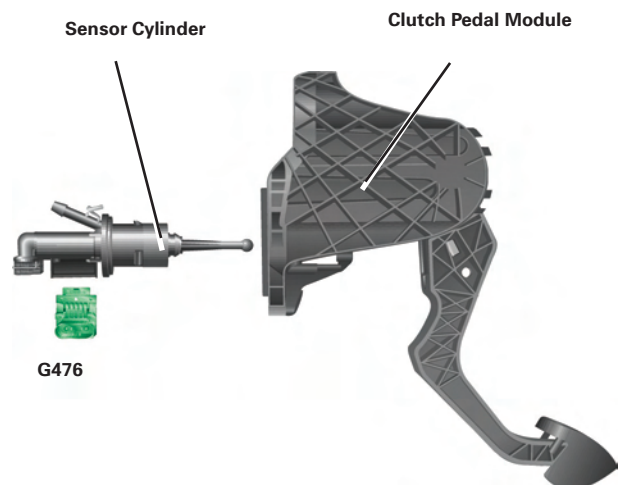

S360\_163

# Engine Management

## The Throttle Drive Angle Sensor 1 G187 and Throttle Drive Angle Sensor 2 G188 in the Throttle Valve Control Unit

These sensors determine the current position of the throttle valve and send this information to the ECM.

### Signal Utilization

The ECM recognizes the position of the throttle valve from the angle sensors signals. The signals from the two sensors are redundant, meaning that both sensors provide the same signal for reasons of safety.

### Effects of a Signal Failure

#### Example 1

The ECM receives an implausible signal or no signal at all from an angle sensor:

- A DTC is set and the EPC light is switched on
- Systems which affect torque, (e.g. cruise control system or engine drag torque control), are switched off
- The load signal is used to monitor the remaining angle sensor
- The accelerator pedal responds normally

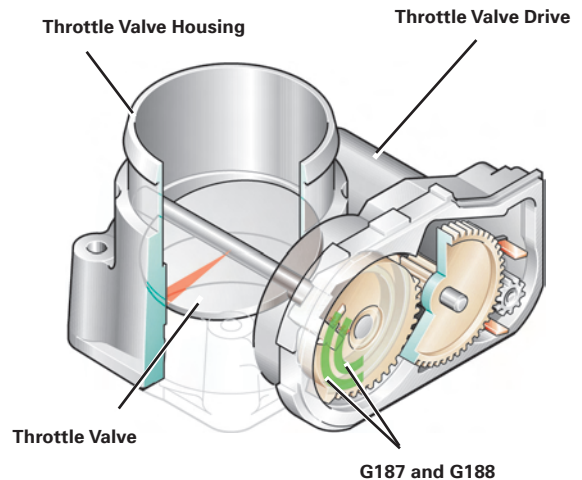

S360\_238

#### Example 2

The ECM receives an implausible signal or no signal from both angle sensors:

- DTCs are set for both sensors and the EPC light is switched on
- The throttle valve drive is switched off
- The engine runs only at an increased idle speed of 1,500 RPM and no longer reacts to the accelerator pedal

## The Camshaft Position Sensors (CMP) G40 and G163

Both Hall sensors are located in the engine timing chain cover. Their task is to communicate the position of the intake and exhaust camshafts to the ECM.

To do this, they scan a quick-start sensor wheel which is located on the individual camshaft.

The ECM recognizes the position of the intake camshaft from the Camshaft Position (CMP) Sensor G40, and recognizes the position of the exhaust camshaft from Camshaft Position (CMP) Sensor 2 G163.

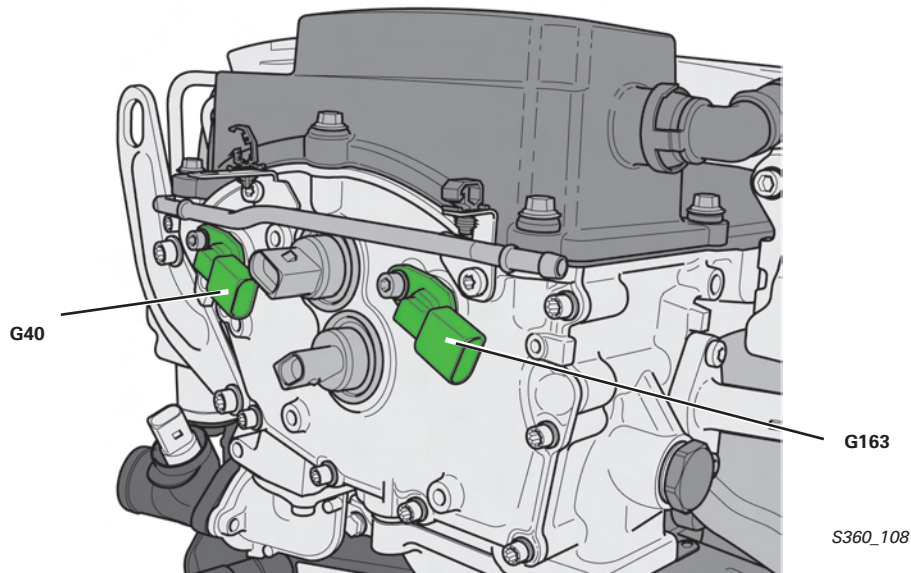

### Signal Utilization

Using the signal from the Camshaft Position Sensors, the precise position of the camshaft relative to the crankshaft is determined very quickly when the engine is started. Used in combination with the signal from the Engine Speed (RPM) Sensor G28, the signals from the Camshaft Position Sensors allow to detect which cylinder is at TDC.

The fuel can be injected into the corresponding cylinder and ignited.

### Effects of a Signal Failure

In case of signal failure, the signal from the Engine Speed (RPM) Sensor G28 is used instead. Because the camshaft position and the cylinder position cannot be recognized as quickly, it may take longer to start the engine.

# Engine Management

## The Engine Coolant Temperature (ECT) Sensor G62

This sensor is located at the coolant distributor above the oil filter on the engine and it informs the ECM of the coolant temperature.

### Signal Utilization

The coolant temperature is used by the ECM for different engine functions. For example, the computation for the injection amount, compressor pressure, start of fuel delivery and the amount of exhaust gas recirculation.

### Effects of a Signal Failure

If the signal fails, the ECM uses the signal from the Engine Coolant Temperature (ECT) Sensor G83.

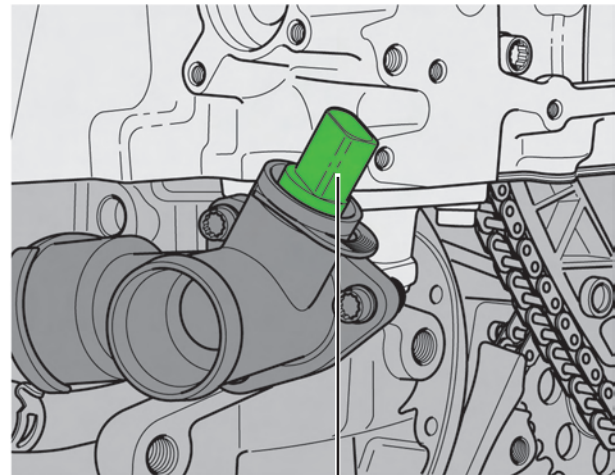

G62

S360\_164

## The Engine Coolant Temperature (ECT) Sensor (on the Radiator) G83

The Engine Coolant Temperature Sensor (on the Radiator) G83 is located in the radiator output line and measures the coolant exit temperature.

### Signal Utilization

The radiator fan is activated by comparing both signal from the Engine Coolant Temperature Sensors G62 and G83.

### Effects of a Signal Failure

If the signal from the Engine Coolant Temperature Sensor G83 is lost, the first speed engine coolant fan is activated permanently.

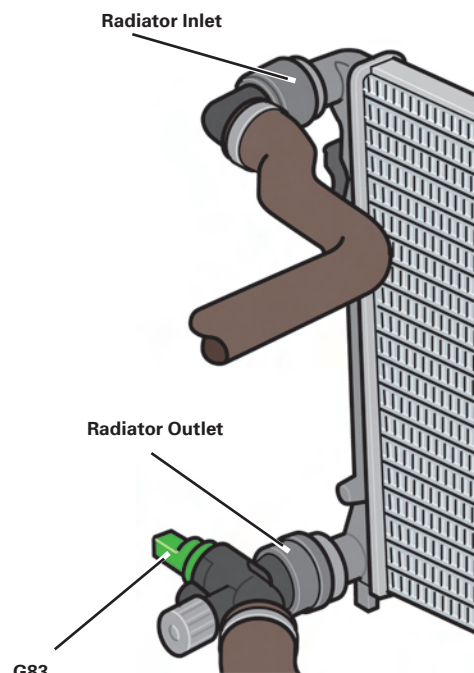

G83

S360\_182



## Knock Sensors (KS) 1 G61 and Knock Sensors (KS) 2 G66

The Knock Sensors are threaded into the crankcase. They detect combustion knocks in individual cylinders. To prevent combustion knock, a cylinder-selective knock control overrides the electronic control of the ignition timing.

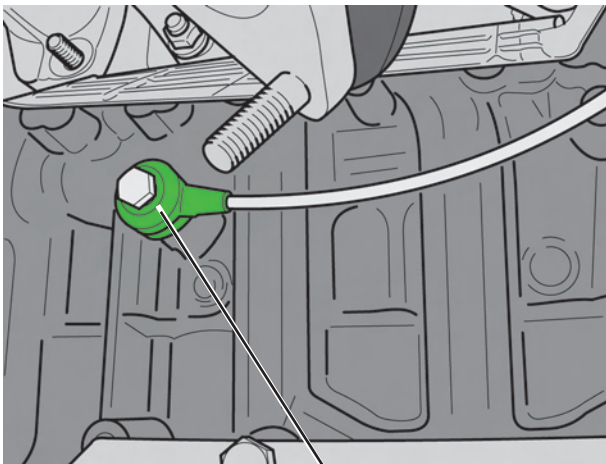

G61

S360\_157

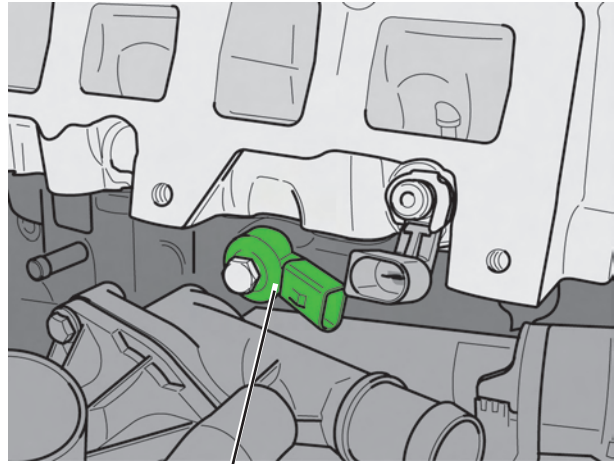

G66

S360\_158

### Signal Utilization

Based on the knock sensor signals, the ECM initiates ignition timing adjustment in the knocking cylinder until knocking stops.

### Effects of a Signal Failure

In the event of a knock sensor failure, the ignition timing for the affected cylinder group is retarded.

This means that a safety timing angle is set in the "late" direction. This can lead to an increase in fuel consumption. Knock control for the cylinder group of the remaining knock sensor remains in effect.

If both knock sensors fail, the engine management system goes into emergency knock control in which the ignition angle is retarded across the board so that full engine power is no longer available.

# Engine Management

## The Brake Light Switch F

The Brake Light Switch is located on the tandem master cylinder. It scans a magnetic ring on the tandem master cylinder piston using a contactless Hall Element.

This switch provides the Engine Control Module with the signal "Brake actuated" via the CAN data bus drive.

### Signal Utilization

When the brake is operated, the cruise control system is deactivated. If the signal "accelerator pedal actuated" is detected first and "brake actuated" is detected next, the idle speed is increased.

### Effects of a Signal Failure

If the sensor signal is lost, the amount of fuel injected is reduced and the engine has less power. The cruise control system is also deactivated.

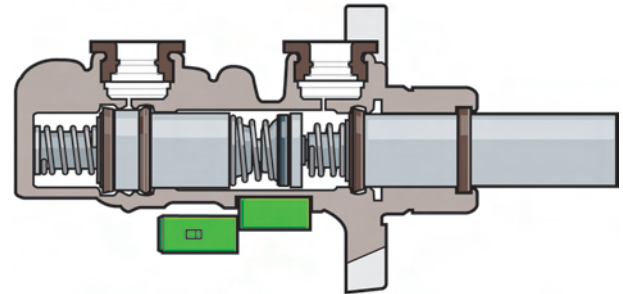

S360\_177

## The Fuel Pressure Sensor G247

The Fuel Pressure Sensor is located on the lower fuel distributor pipe. It measures the fuel pressure in the high-pressure fuel system.

### Signal Utilization

The ECM analyzes the signal and regulates the fuel high pressure through the Fuel Pressure Regulator Valve N276 in the high-pressure pump.

### Effects of a Signal Failure

If the Fuel Pressure Sensor fails, the fuel pressure regulator valve is activated at a fixed value by the ECM.

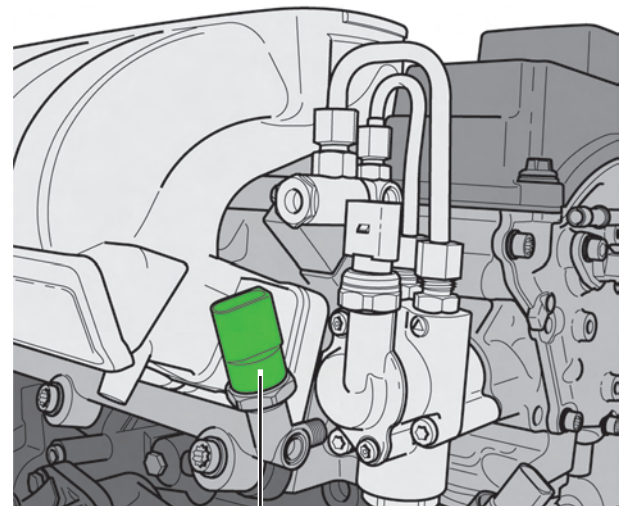

S360\_110

G247

## The Low Fuel Pressure Sensor G410

The Low Fuel Pressure Sensor is located on the high-pressure fuel pump. It measures the fuel pressure in the low-pressure fuel system.

### Signal Utilization

The signal is used by the ECM to regulate the low-pressure fuel system. Based on the signal from the sensor, a signal is sent by the ECM to the Fuel Pump Control Module J538, which then regulates the fuel pump as needed.

### Effects of a Signal Failure

If the Low Fuel Pressure Sensor fails, the fuel pressure is not regulated as needed. Fuel pressure is maintained at a constant 72 psi (5 bar).

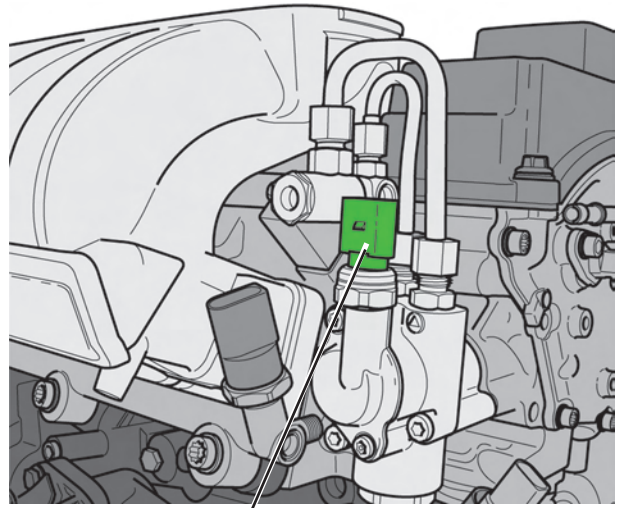

G410

S360\_109

## The Oil Level Thermal Sensor G266

The Oil Level Thermal Sensor is threaded into the oil pan from below. Its signal is used by several control modules.

### Signal Utilization

The ECM receives the signal over the CAN data bus and uses the oil temperature signal to control the retarded setting of the exhaust camshaft at high oil temperatures.

### Effects of a Signal Failure

The control module uses instead the signal from the Coolant Temperature Sensor.

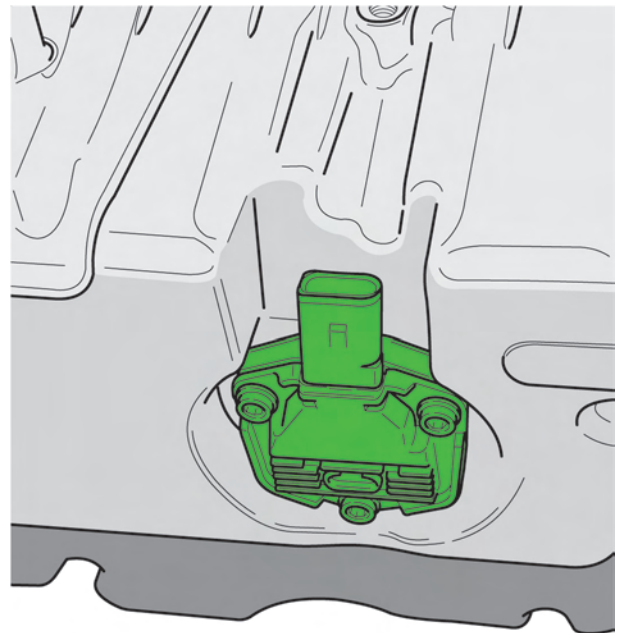

S360\_156

# Engine Management

## The Heated Oxygen Sensors (HO2S) G39 and the Heated Oxygen Sensors (HO2S) 2 G108

A broadband oxygen sensor is assigned to each pre-catalytic converter as a pre-catalytic oxygen sensor. Using the broadband oxygen sensors, a wide range of oxygen concentration in the exhaust gas can be determined, allowing to derive information about the air-fuel ratio in the combustion chamber. Both oxygen sensors are heated to reach operating temperature more quickly.

### Signal Utilization

The signals from the Heated Oxygen Sensors are one of the variables used in calculating the injection timing.

### Effects of a Signal Failure

If the pre-catalytic converter oxygen sensor fails, there is no closed loop control. The fuel injection adaptation is not available. An emergency running mode is enabled using an engine characteristics map.

## The Oxygen Sensor (O2S) Behind Three Way Catalytic Converter G130 and the Oxygen Sensor (O2S) 2 Behind Three Way Catalytic Converter G131

The planar oxygen sensors are located downstream of the pre-catalytic converter. They measure the remaining oxygen content in the exhaust gas. Based on the amount of oxygen remaining in the exhaust gas, the ECM can draw conclusions about the catalytic converter operation.

### Signal Utilization

The ECM uses the signals from the post-catalytic converter oxygen sensors to check the catalytic converter operation and the closed-loop oxygen control system.

### Effects of a Signal Failure

If the post-catalytic converter oxygen sensor fails, the closed loop operation continues. The operation of the catalytic converter can no longer be checked.

Broadband Oxygen Sensor

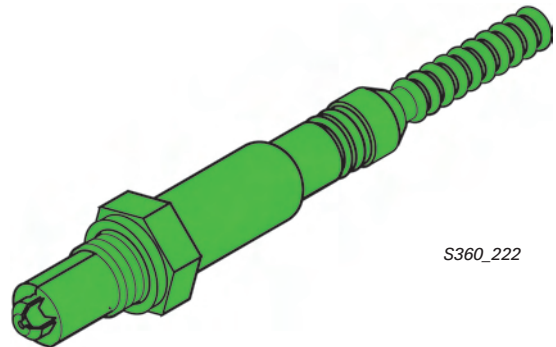

S360\_222

Planar Oxygen Sensor

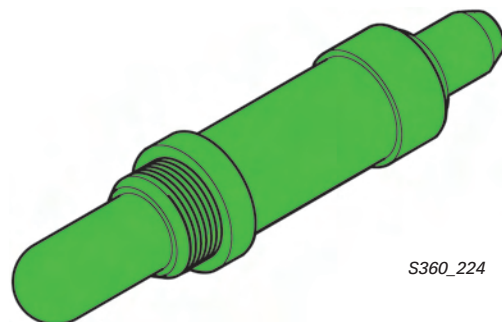

S360\_224

## The Actuators

### Camshaft Adjustment Valve 1 N205, Camshaft Adjustment Valve 1 (exhaust) N318

The solenoid valves are integrated in the camshaft adjustment housing. They distribute the oil pressure based on the ECM signals for the adjustment direction and adjustment travel at the camshaft adjusters.

Both camshafts are continuously adjustable:

- Intake camshaft at 52° of the crankshaft angle
- Exhaust camshaft at 42° of the crankshaft angle
- Maximum valve overlap angle 47°

The exhaust camshaft is mechanically locked when no oil pressure is available (engine not running).

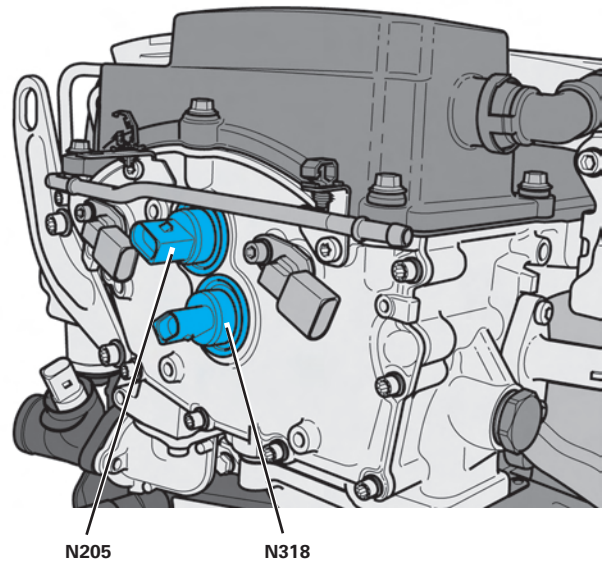

S360\_161

### Effects of a Signal Failure

If an electrical lead to the camshaft adjusters is defective or if a camshaft adjuster fails because it is mechanically seized or as a result of inadequate oil pressure, there is no camshaft adjustment.

# Engine Management

## The Transfer Fuel Pump (FP) G6 and the Fuel Level Sensor G

The Transfer Fuel Pump and the Fuel Filter are combined in the Fuel Transfer Unit. The Fuel Transfer Unit is located in the fuel tank.

### Operation

The Transfer Fuel Pump transfers the fuel in the low-pressure fuel system to the high-pressure fuel pump. It is activated by a Pulse Width Modulation (PWM) signal from the Fuel Pump Control Module.

The Transfer Fuel Pump transfers as much fuel as the engine requires at any point in time.

### Effects of a Failure

If the Transfer Fuel Pump fails, engine operation is not possible.

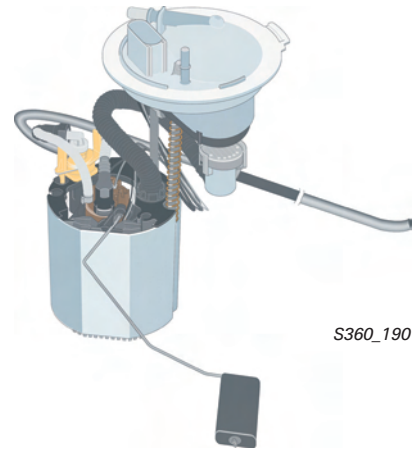

## The Fuel Pressure Regulator Valve N276

The Fuel Pressure Regulator Valve is located on the underside of the High-Pressure Fuel Pump.

The ECM regulates the fuel high-pressure through the Fuel Pressure Regulator Valve at a level between 507 and 1,450 psi (35 and 100 bar).

### Effects of a Failure

The ECM goes into emergency running mode.

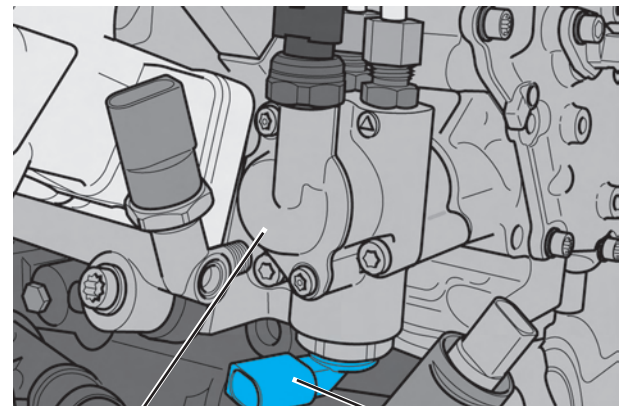

High-Pressure Fuel Pump

N276



## The Ignition Coils 1-6 with Power Output Stage N70, N127, N291, N292, N323, N324

The ignition coil and power output stage are one component. The ignition timing is controlled individually for each cylinder.

### Effects of a Failure

If an ignition coil fails, fuel injection for the affected cylinder is switched off. This is possible for a maximum of two cylinders.

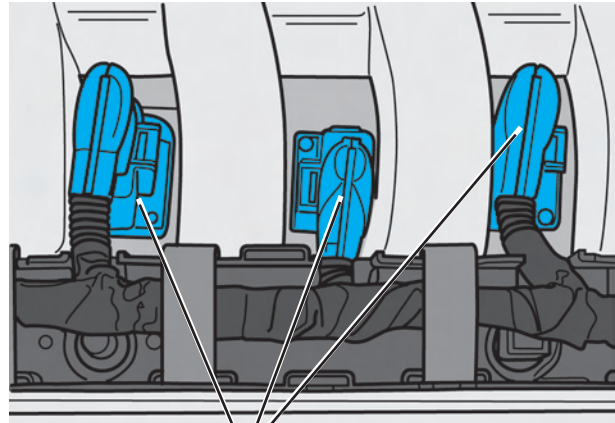

Ignition Coils

S360\_192

## The Evaporative Emission (EVAP) Canister Purge Regulator Valve N80

The Evaporative Emission Canister Purge Regulator Valve is located on the front (belt drive side) of the engine and is triggered by the ECM. The fuel vapors collected in the evaporative emission canister are sent for combustion and thus the evaporative emission canister is emptied.

### Effects of a Signal Failure

If the current is interrupted, the valve remains closed. The fuel tank is not vented.

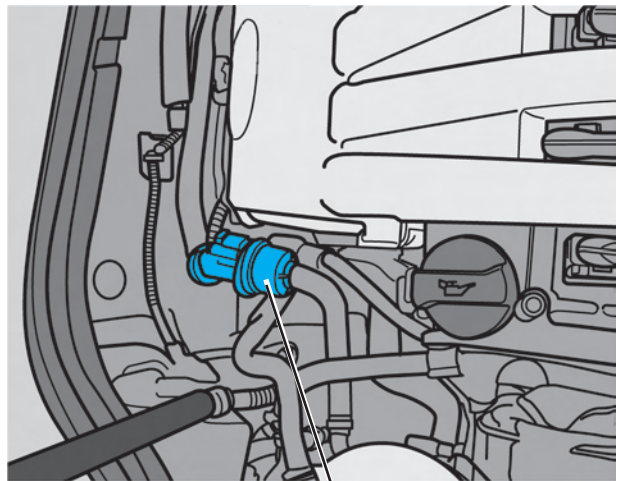

N80

S360\_406

# Engine Management

## The Cylinders 1-6 Fuel Injectors N30, N31, N32, N33, N83, N84

The High-Pressure FSI Fuel Injectors are inserted into the cylinder head. They are triggered by the ECM in accordance with the firing orders. When triggered, they spray fuel directly into the cylinder.

Due to the design of the engine, injection takes place from one side. For this reason, the fuel injectors for cylinder bank 1, 3 and 5 are longer than the fuel injectors for cylinder bank 2, 4 and 6.

### Effects of a Failure

A defective fuel injector is recognized by misfire detection and is no longer triggered.

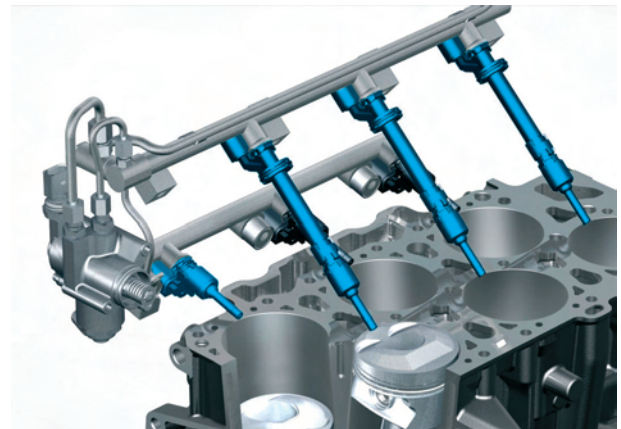

S360\_137

## Throttle Drive for Electronic Power Control (EPC) G186

The Throttle Drive for Electronic Power Control is an electrical motor which operates the throttle valve through a gear mechanism.

The range of adjustment is stepless from idle to the wide-open throttle position.

### Effects of a Failure

If the throttle drive fails, the throttle valve is automatically pulled to the emergency running position. An entry is made in the DTC memory and the EPC lamp is switched on.

The driver has only emergency features available. The comfort functions are switched off.

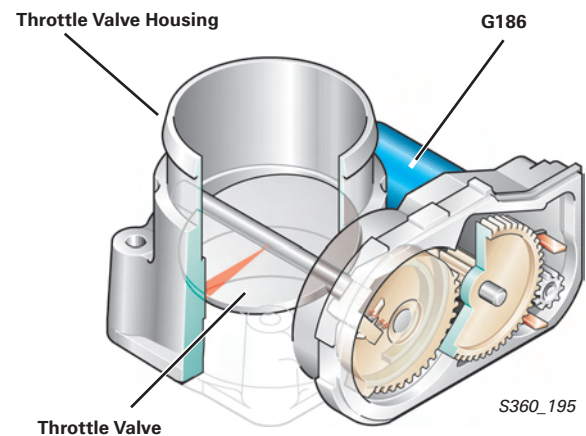

S360\_195

## Intake Manifold Runner Control Valve N316

The Intake Manifold Runner Control Valve is located on the variable intake manifold and is an electropneumatic valve.

When it is activated, it operates the intake manifold flap to change the length of the intake manifold.

### Effects of a Failure

If the valve fails, the intake manifold flaps are pulled by a mechanical spring to an emergency running position. This position corresponds to the power setting of the intake manifold.

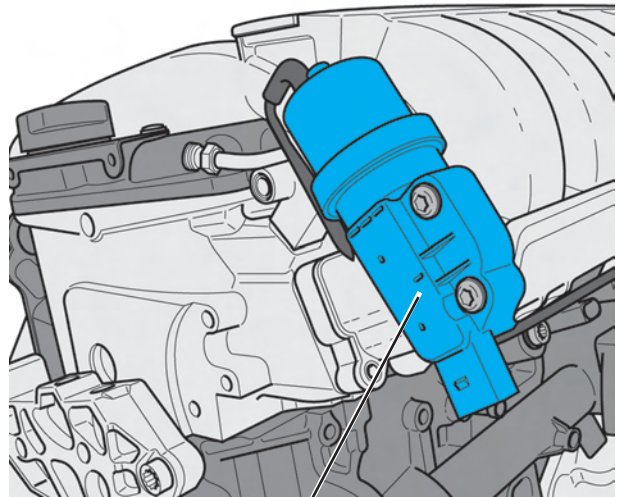

N316

S360\_051

## The Recirculation Pump V55

The Recirculation Pump is activated by the ECM. It assists the mechanical coolant pump when the engine is running. After the engine is turned off and with a lack of moving air resulting from the vehicle motion, the Recirculation Pump is switched on depending on the coolant temperature, and prevents a heat buildup in the engine.

### Effects of a Failure

If the Recirculation Pump fails, the engine may overheat.

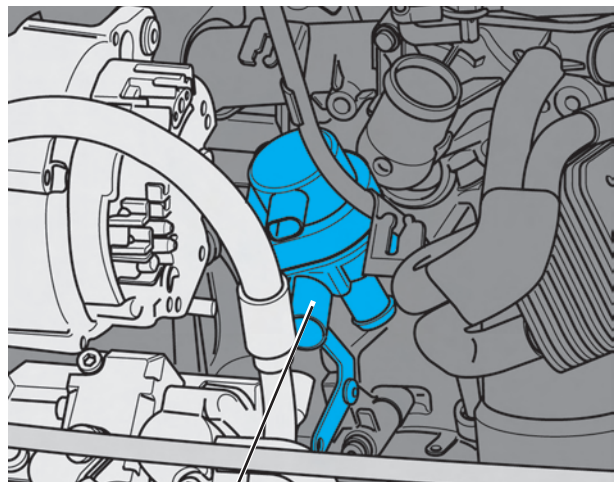

V55

S360\_045

# Engine Management

## Oxygen Sensor (O2S) Heaters Z19, Z28, Z29 and Z30

The job of the Oxygen Sensor Heater is to bring the ceramic of the oxygen sensor rapidly up to its operating temperature of approx. 1652°F (900°C) when the engine is started and the temperature is low. The oxygen sensor heater is controlled by the ECM.

### Effects of a Failure

The engine can no longer be regulated with respect to the emissions.

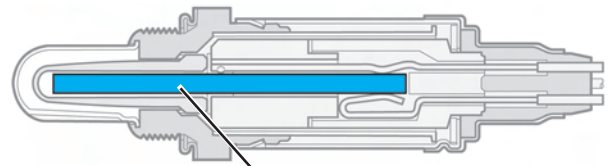

S360\_193

Oxygen Sensor Heater

## The Control Modules in the CAN Data Bus

The schematic below shows the Engine Control Module J623 integrated into the CAN data bus structure of the vehicle. Information is exchanged between the control modules over the CAN data bus.

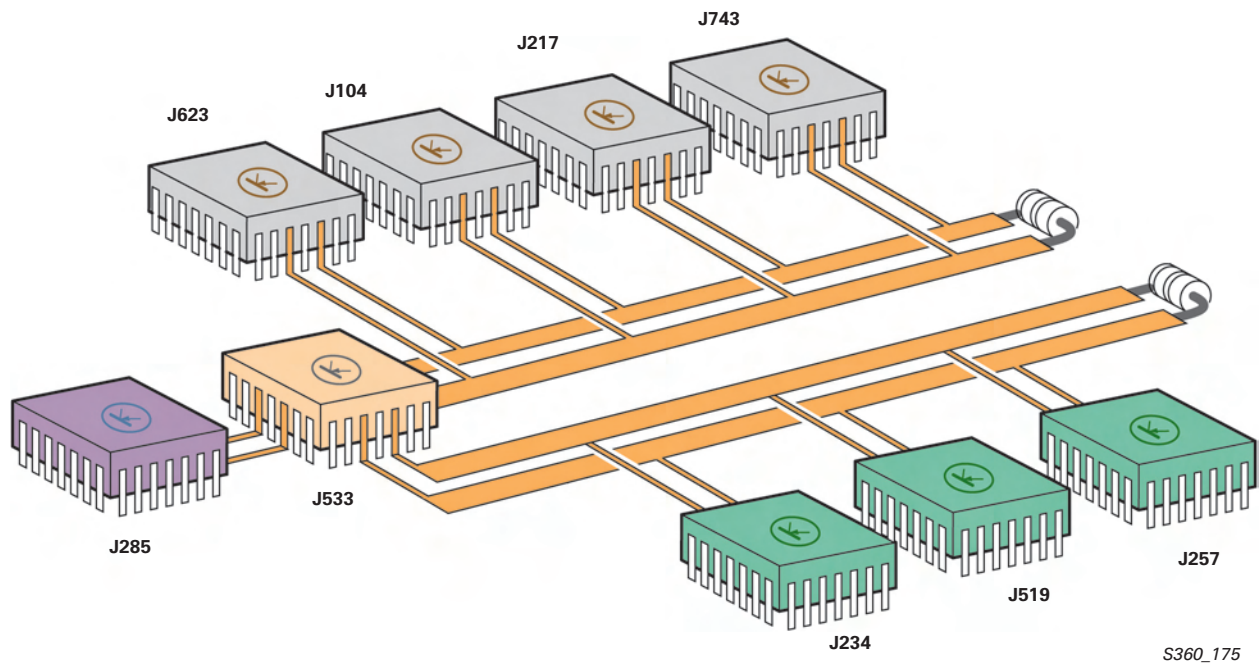

### Legend

- J623 Engine Control Module (ECM)
- J104 ABS Control Module
- J217 Transmission Control Module (TCM)
- J234 Airbag Control Module
- J285 Instrument Cluster Control Module
- J519 Vehicle Electrical System Control Module
- J527 Steering Column Electronic Systems Control Module
- J533 Data Bus On Board Diagnostic Interface
- J743 Direct Shift Gearbox (DSG) Mechatronic

### Color coding

- Powertrain CAN-bus
- Comfort system CAN-bus
- Infotainment CAN-bus



# Operating Diagrams

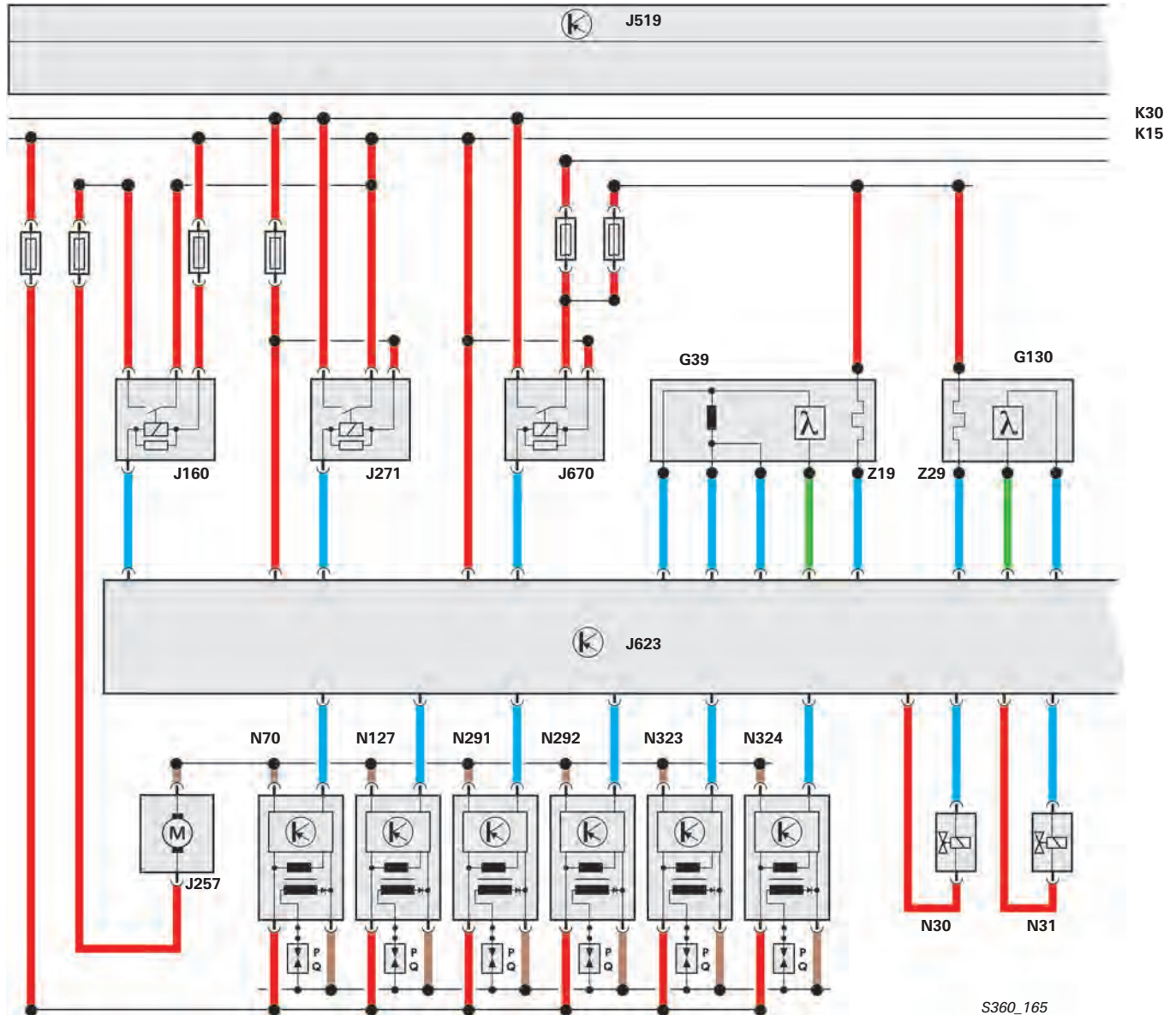

K30  
K15

S360\_165

- |             |  |             |   |
|-------------|--|-------------|---|
| <b>G39</b>  | Heated Oxygen Sensor (HO2S)                                    | <b>N127</b> | Ignition Coil 2 with Power Output Stage                                   |
| <b>G130</b> | Oxygen Sensor (O2S) Behind Three Way Catalytic Converter (TWC) | <b>N291</b> | Ignition Coil 3 with Power Output Stage                                   |
| <b>J160</b> | Recirculation Pump Relay                                       | <b>N292</b> | Ignition Coil 4 with Power Output Stage                                   |
| <b>J271</b> | Motronic Engine Control Module (ECM) Power Supply Relay        | <b>N323</b> | Ignition Coil 5 with Power Output Stage                                   |
| <b>J519</b> | Vehicle Electrical System Control Module                       | <b>N324</b> | Ignition Coil 6 with Power Output Stage                                   |
| <b>J623</b> | Engine Control Module (ECM)                                    | <b>Z19</b>  | Oxygen Sensor (O2S) Heater  |
| <b>J670</b> | Motronic Engine Control Module (ECM) Power Supply Relay 2      | <b>Z29</b>  | Oxygen Sensor (O2S) 1 (behind Three Way Catalytic Converter (TWC)) Heater |
| <b>N30</b>  | Cylinder 1 Fuel Injector                                       |             |   |
| <b>N31</b>  | Cylinder 2 Fuel Injector                                       |             |   |
| <b>N70</b>  | Ignition Coil 1 with Power Output Stage                        |             |   |



# Operating Diagrams

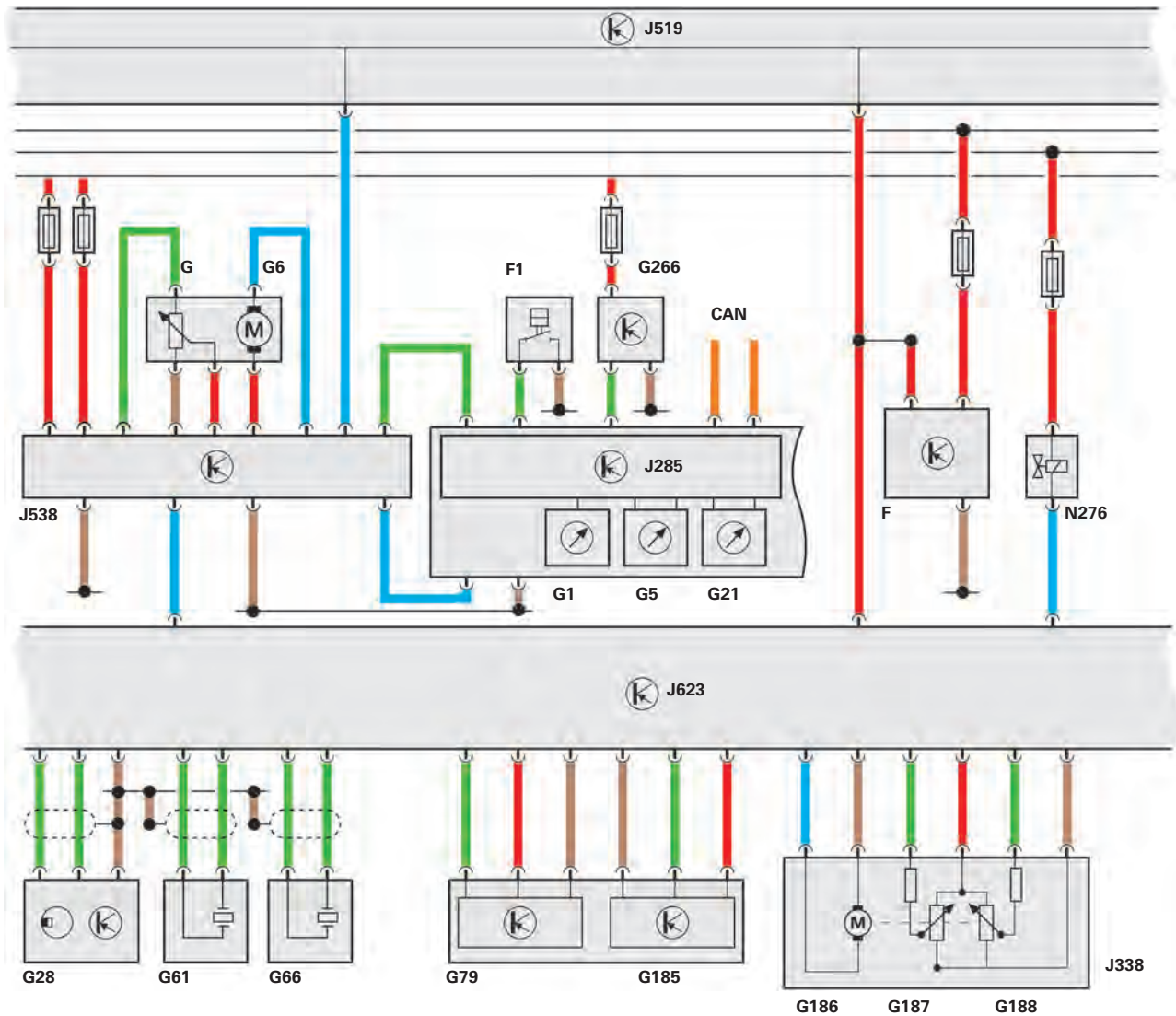

S360\_166

- |             |   |             |  |
|-------------|---|-------------|--|
| <b>F</b>    | Brake Light Switch                                  | <b>G187</b> | Throttle Drive Angle Sensor 1 (for Electronic Power Control (EPC)) |
| <b>F1</b>   | Oil Pressure Switch                                 | <b>G188</b> | Throttle Drive Angle Sensor 2 (for Electronic Power Control (EPC)) |
| <b>G</b>    | Fuel Level Sensor                                   | <b>G266</b> | Oil Level Thermal Sensor   |
| <b>G1</b>   | Fuel Gauge  | <b>J285</b> | Instrument Cluster Control Module                                  |
| <b>G5</b>   | Tachometer  | <b>J338</b> | Throttle Valve Control Module                                      |
| <b>G6</b>   | Transfer Fuel Pump (FP)                             | <b>J538</b> | Fuel Pump (FP) Control Module                                      |
| <b>G21</b>  | Speedometer   | <b>J623</b> | Engine Control Module (ECM)  |
| <b>G28</b>  | Engine Speed (RPM) Sensor                           | <b>N276</b> | Fuel Pressure Regulator Valve                                      |
| <b>G61</b>  | Knock Sensor (KS) 1                                 |             |  |
| <b>G66</b>  | Knock Sensor (KS) 2                                 |             |  |
| <b>G79</b>  | Throttle Position (TP) Sensor                       |             |  |
| <b>G185</b> | Accelerator Pedal Position Sensor 2                 |             |  |
| <b>G186</b> | Throttle Drive (for Electronic Power Control (EPC)) |             |  |

# Operating Diagrams

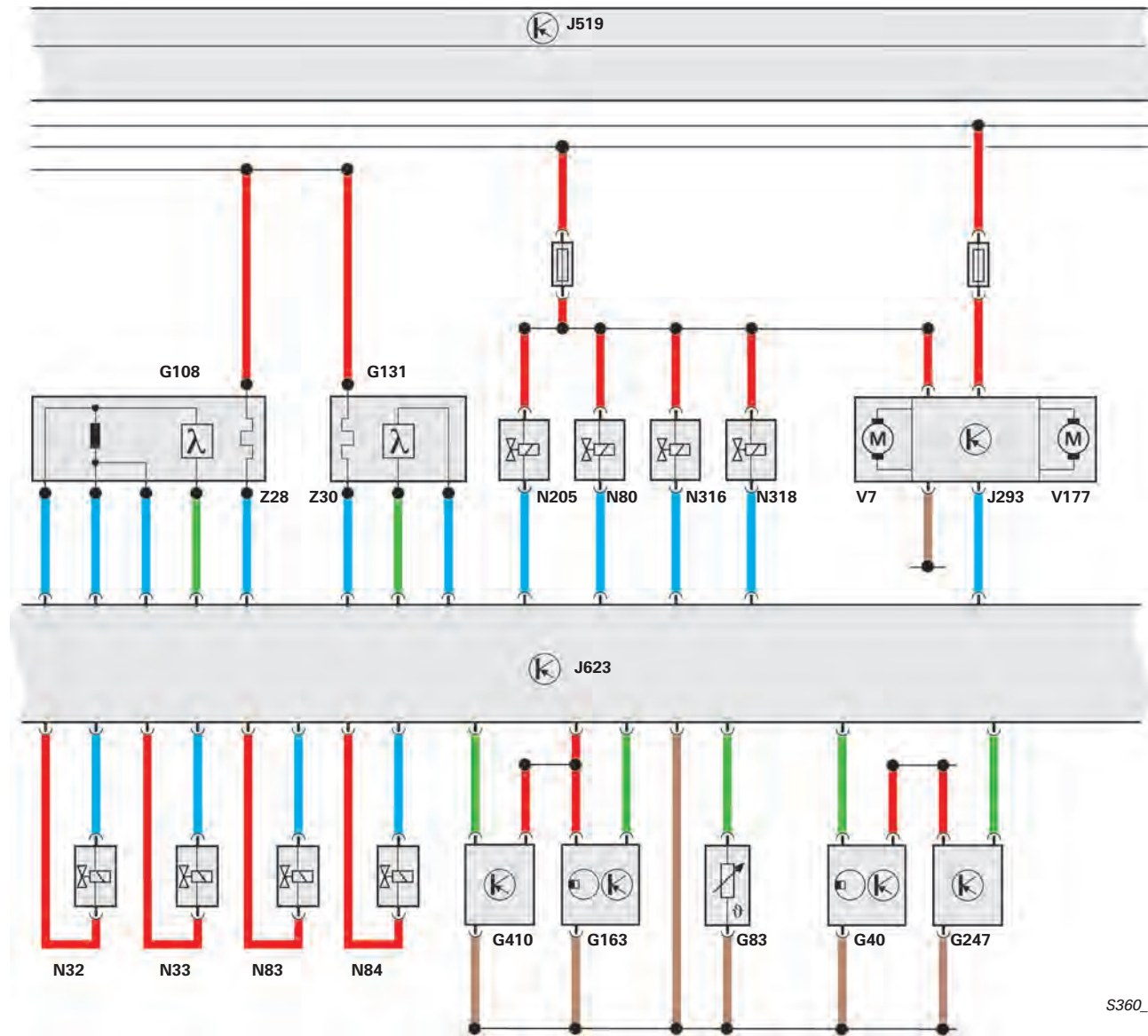

S360\_167

- |  |   |
|--|---|
| <b>G40</b> Camshaft Position (CMP) Sensor                                    | <b>N33</b> Cylinder 4 Fuel Injector                                   |
| <b>G83</b> Engine Coolant Temperature (ECT) Sensor (on Radiator)             | <b>N80</b> Evaporative Emission (EVAP) Canister Purge Regulator Valve |
| <b>G108</b> Heated Oxygen Sensor (HO2S) 2                                    | <b>N83</b> Cylinder 5 Fuel Injector                                   |
| <b>G131</b> Oxygen Sensor (O2S) 2 Behind Three Way Catalytic Converter (TWC) | <b>N84</b> Cylinder 6 Fuel Injector                                   |
| <b>G163</b> Camshaft Position (CMP) Sensor 2                                 | <b>N205</b> Camshaft Adjustment Valve 1                               |
| <b>G247</b> Fuel Pressure Sensor   | <b>N316</b> Intake Manifold Runner Control (IMRC) Valve               |
| <b>G410</b> Low Fuel Pressure Sensor   | <b>N318</b> Camshaft Adjustment Valve 1 (exhaust)                     |
|  | <b>V7</b> Coolant Fan   |
|  | <b>V177</b> Coolant Fan 2   |
| <b>J293</b> Coolant Fan Control (FC) Control Module                          |   |
| <b>J519</b> Vehicle Electrical System Control Module                         |   |
| <b>J623</b> Engine Control Module (ECM)                                      |   |
| <b>N32</b> Cylinder 3 Fuel Injector  |   |

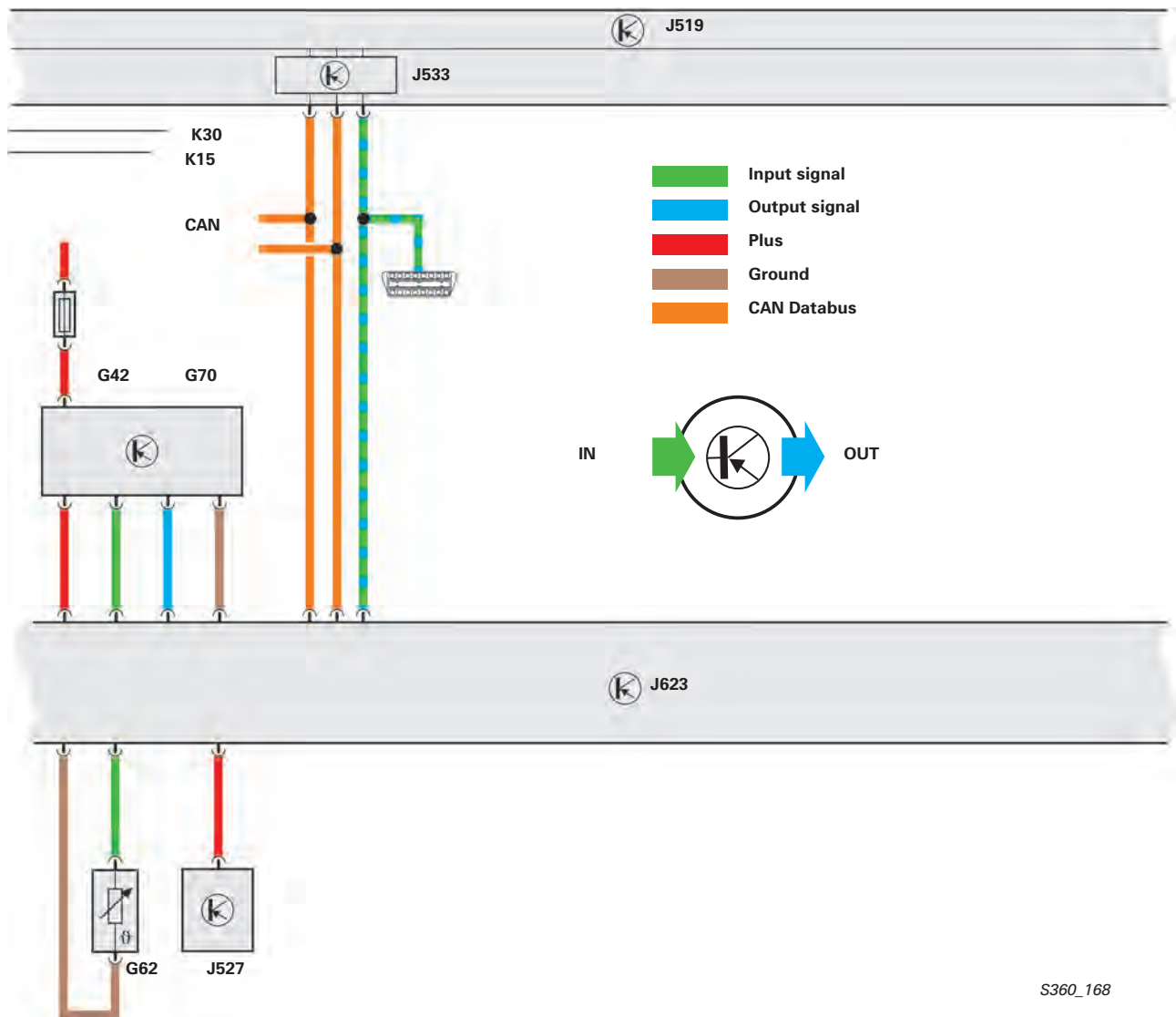

S360\_168



- G62** Engine Coolant Temperature (ECT) Sensor
- G42** Intake Air Temperature (IAT) Sensor
- G70** Mass Air Flow (MAF) Sensor

- Z28** Oxygen Sensor (O2S) 2 Heater
- Z30** Oxygen Sensor (O2S) 2 (behind Three Way Catalytic Converter (TWC)) Heater

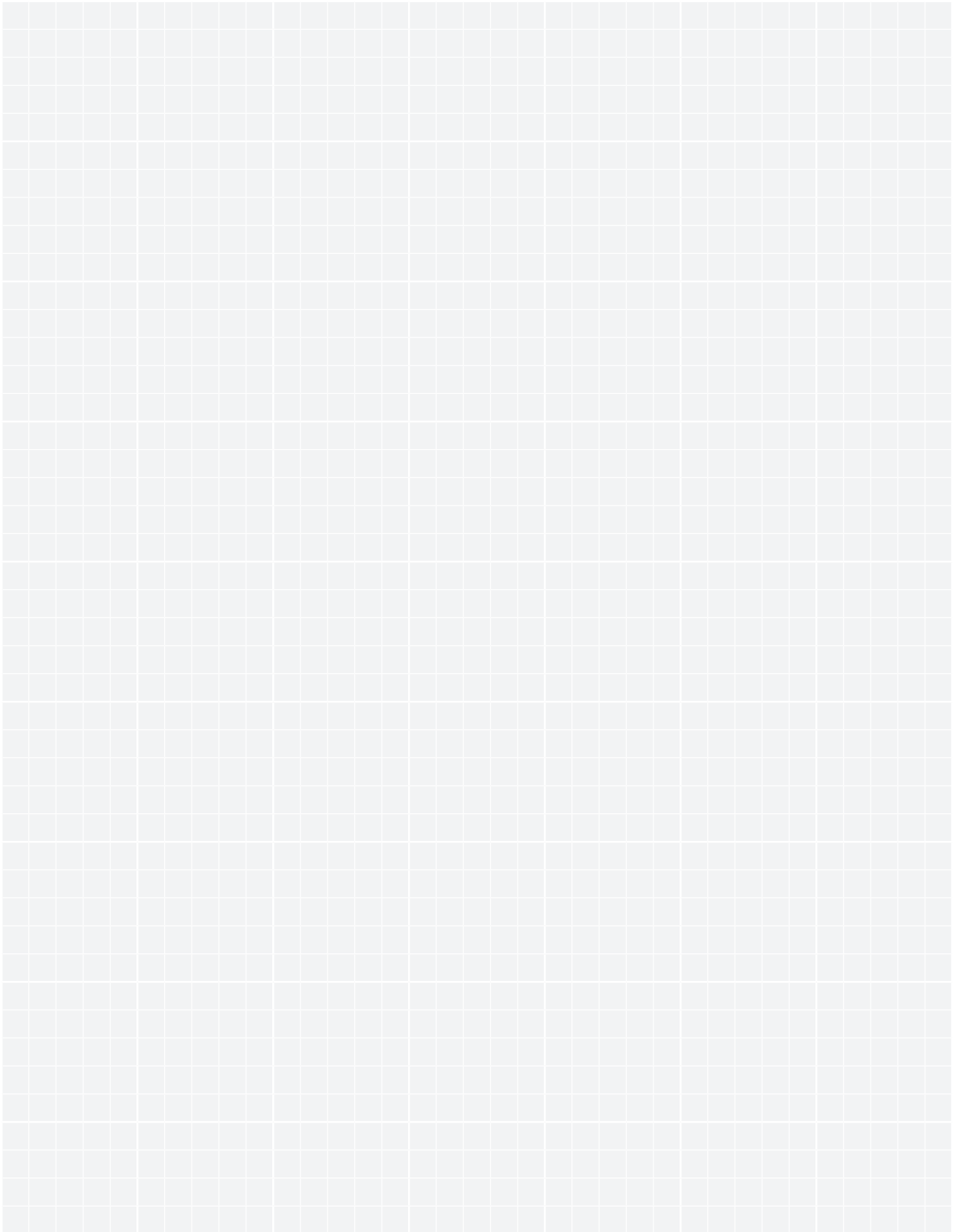
- J519** Vehicle Electrical System Control Module
- J527** Steering Column Electronic Systems Control Module
- J533** Data Bus On Board Diagnostic Interface
- J623** Engine Control Module (ECM)

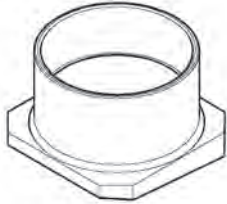

## Special Tools

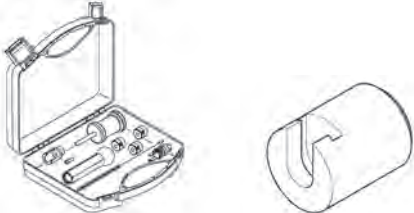
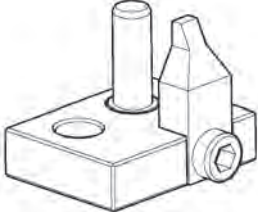
Description	Tool	Use
Funnel T 10333		The Funnel T 10333 is used for installing the pistons on the 3.6 V6 FSI engine.
Puller T10055 Adapter T 10055/3		The Puller T10055 with Adapter T 10055/3 is used to remove the oil pump.
Tool Set T 10133 Puller T 10133/10		The Tool Set T 10133 with Puller T 10133/10 is needed to remove the fuel injectors.
Adjusting tool T 10332		The Adjusting Tool T 10332 must be used to lock the pinion on the high-pressure fuel pump drive.

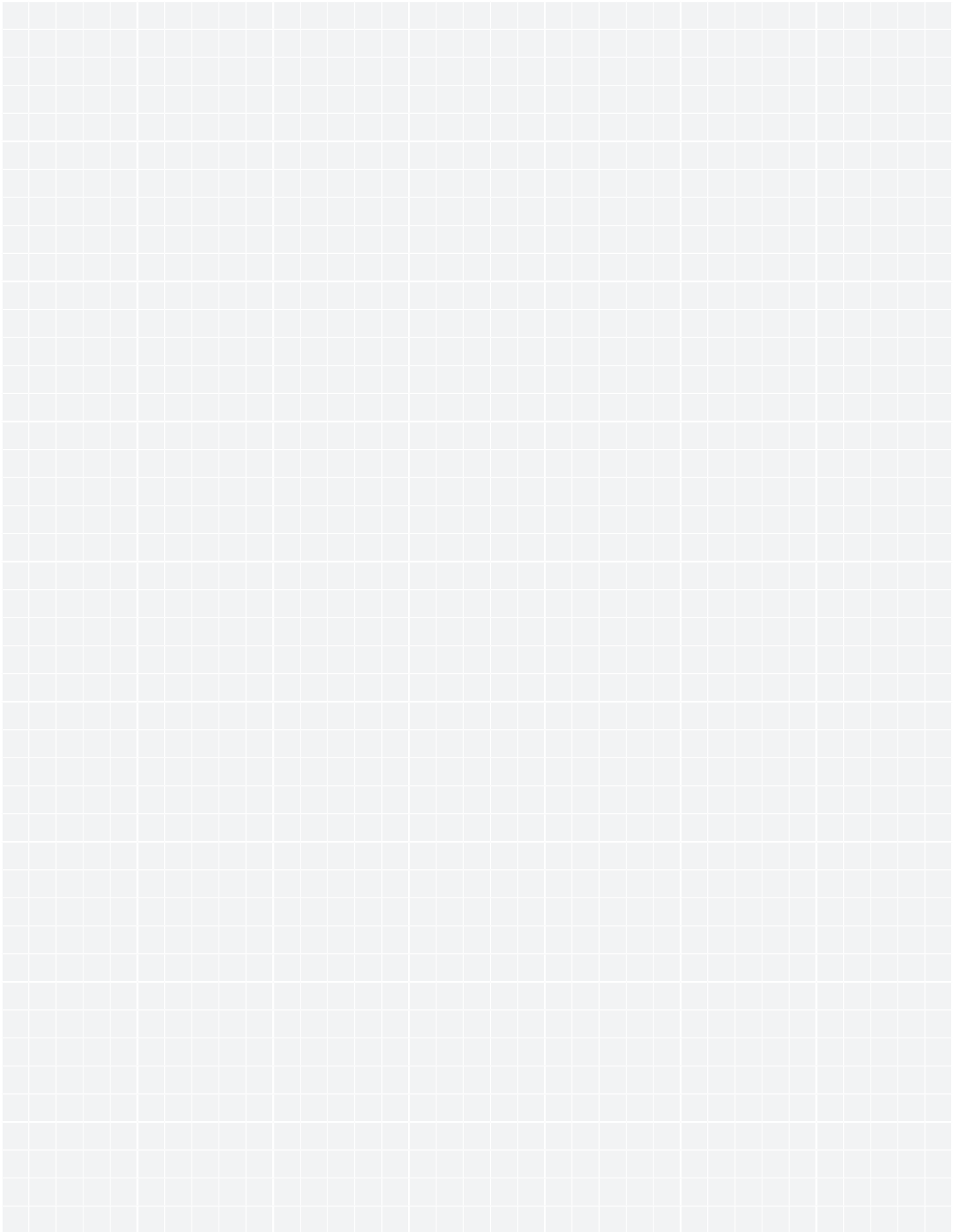



# Knowledge Assessment

An on-line Knowledge Assessment (exam) is available for this Self-Study Program.

The Knowledge Assessment may or may not be required for Certification.

You can find this Knowledge Assessment at:

**[www.accessaudi.com](http://www.accessaudi.com)**

For assistance, please call:

**Audi Academy**

**Learning Management Center Headquarters**

**1-877-AUDI-LMC (283-4562)**

**(8:00 a.m. to 8:00 p.m. EST)**

All rights reserved.

Technical specifications

subject to change without notice

Audi of America, Inc.

3800 Hamlin Road

Auburn Hills, MI 48326