

# The new Jetta Electrical System Design and Function



**Self-Study Program**  
**Course Number 873403**



---

Volkswagen of America, Inc.  
Volkswagen Academy  
Printed in U.S.A.  
Printed 12/2004  
Course Number 891403

©2004 Volkswagen of America, Inc.

All rights reserved. All information contained in this manual is based on the latest information available at the time of printing and is subject to the copyright and other intellectual property rights of Volkswagen of America, Inc., its affiliated companies and its licensors. All rights are reserved to make changes at any time without notice. No part of this document may be reproduced, stored in a retrieval system, or transmitted in any form or by any means, electronic, mechanical, photocopying, recording or otherwise, nor may these materials be modified or reposted to other sites without the prior expressed written permission of the publisher.

All requests for permission to copy and redistribute information should be referred to Volkswagen of America, Inc.

Always check Technical Bulletins and the latest electronic repair information for information that may supersede any information included in this booklet.

Trademarks: All brand names and product names used in this manual are trade names, service marks, trademarks, or registered trademarks; and are the property of their respective owners.

---

# Table of Contents

---

<b>Introduction</b> .....	<b>1</b>
Course Introduction, Electrical System Fuses and Relays, Communication Network, Drivetrain CAN-bus Control Modules, Convenience CAN-bus Control Modules, Infotainment CAN-bus Control Modules, Instrument Cluster and Diagnostic CAN-bus Control Modules	
<b>LIN Bus</b> .....	<b>14</b>
LIN Bus	
<b>Power Supply</b> .....	<b>16</b>
Electrical Box, Relay Carrier, Fuse Box, Data Bus On Board Diagnostic Interface J533, Transport Mode, Vehicle Electrical System Control Module J519, Exterior Light Control, Convenience Lighting, Windshield Wiper System, Headlight Washer System, Windshield Washer Quick Disconnect/Lock System, Instrument Cluster Control Module J285, Anti-Theft Immobilizer Control Module J362, Warning Lights in the Instrument Cluster, Comfort System Central Control Module J393	
<b>Convenience and Safety Systems</b> .....	<b>41</b>
Personalization, Accessing Programming Menus, Radios, Antennas, Multi-Function Steering Wheel, Headliner Printed Circuits, Tamper-Proof Guard	

**New!**

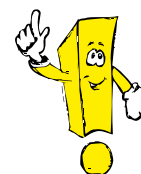

**Important/Note!**



This Self-Study Program covers the electrical system of the new Jetta!

**This Self-Study Program is not a Repair Manual. This information will not be updated.**

For testing, adjustment and repair procedures, always refer to the latest electronic service information.





## Course Introduction

The new Jetta makes extensive use of control modules and networking using multiple Controller Area Network (CAN) buses. Signals are transmitted digitally from one control module to another on each CAN-bus, eliminating the need for a separate wire for each signal. The use of CAN-bus communication for controls and accessories reduces the wires needed in the vehicle.

This Self-Study Program covers the new Jetta's electrical system. This program also describes the new control modules, the networking of various body electrical systems, and the various CAN-bus systems.



S873403\_13

# Introduction

---

## Electrical System Fuses and Relays

### Locations

The electrical system on the new Jetta is entirely redesigned. Because of this, the mounting location of fuse and relay centers have changed.

The adjacent diagram shows the various locations.



Fuse and relay center under the hood on the driverside



Back-up fuse box under the hood on the driverside



Fuse box behind the instrument cluster

# Introduction

Relay carrier below the instrument cluster on the driverside, above the on board power supply control module

Relay carrier of on board power supply control module, on left under the instrument cluster

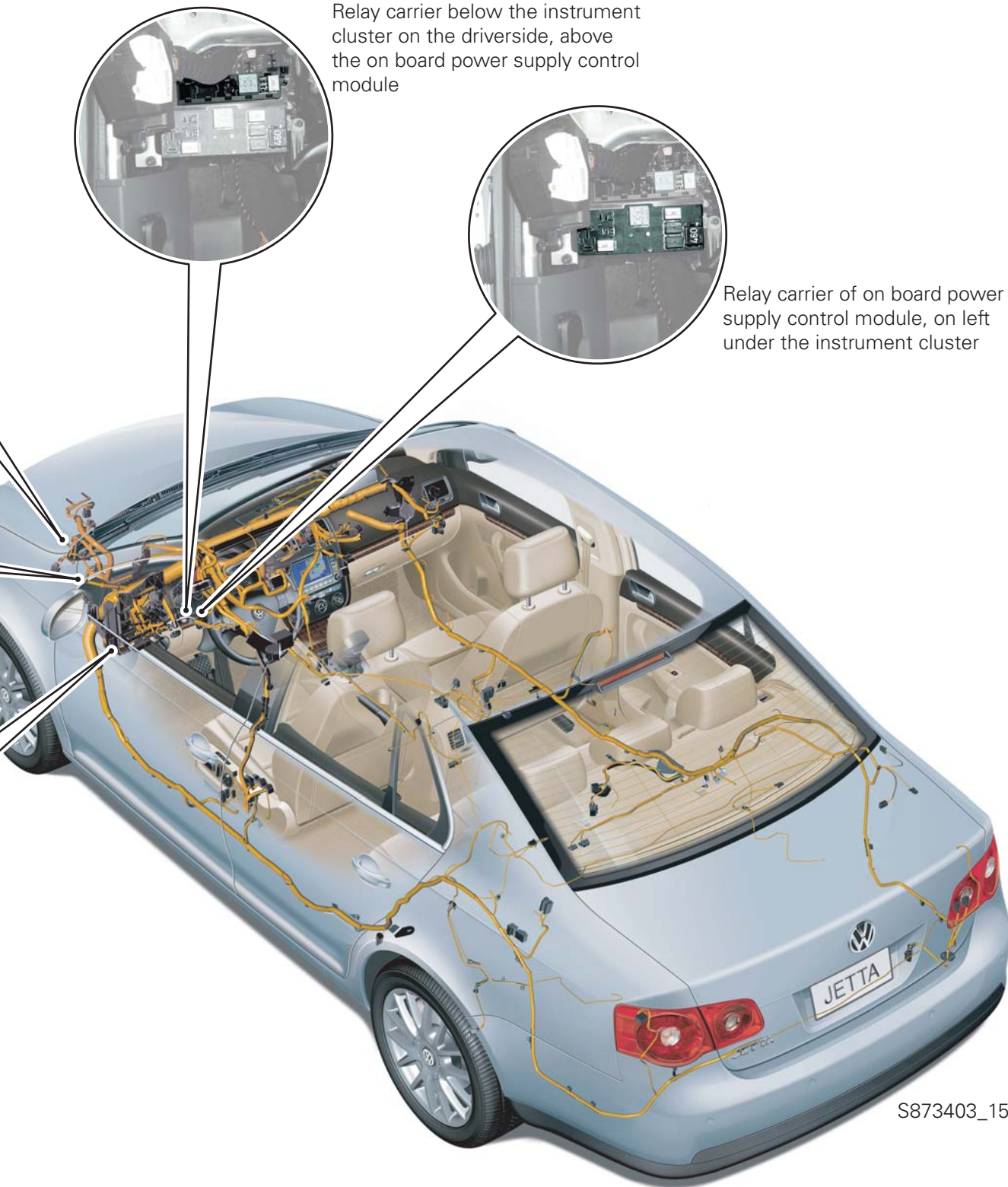

S873403\_15

# Introduction

---

## Communication Network

### Overview of Networked Control Modules

To allow communication between the control modules without interference, they are connected by several data bus systems.

The Data Bus On Board Diagnostic Interface J533 (Gateway) allows communication between the following data buses:

- Drivetrain CAN-bus
- Convenience CAN-bus
- Infotainment CAN-bus
- Instrument cluster CAN-bus
- Diagnosis CAN-bus

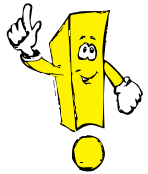

In addition to the CAN-bus, some electric components communicate through the LIN bus.

### Key

D	Ignition/Starter Switch
E221	Control Module in Steering Wheel
G85	Steering Angle Sensor
G397	Rain/Light Recognition Sensor
H8	Alarm Horn
J104	ABS Control Module
J136	Memory Seat/Steering Column Adjustment Control Module
J217	Transmission Control Module (TCM)
J220	Motronic Engine Control Module
J234	Airbag Control Module
J255	Climatronic Control Module
J285	Instrument Cluster Control Module
J334	Anti-Theft Engine Disable Control Module
J364	Auxiliary Heater Control Module
J386	Driver's Door Control Module
J387	Front Passenger's Door Control Module
J388	Left Rear Door Control Module
J389	Right Rear Door Control Module
J393	Comfort System Central Control Module
J400	Wiper Motor Control Module
J431	Headlamp Range Control Module
J446	Parking Aid Control Module
J500	Power Steering Control Module
J503	Radio/Navigation Display Control Module
J519	Vehicle Electrical System Control Module
J525	Digital Sound System Control Module
J527	Steering Column Electronic Systems Control Module
J533	Data Bus On Board Diagnostic Interface
J587	Selector Lever Sensor System Control Module*
J604	Auxiliary Air Heater Control Module
J743*	Direct Shift Gearbox (DSG) Mechatronic
R	Radio
T16	16-Pin Connector

\*On direct shift gearboxes only



# Introduction

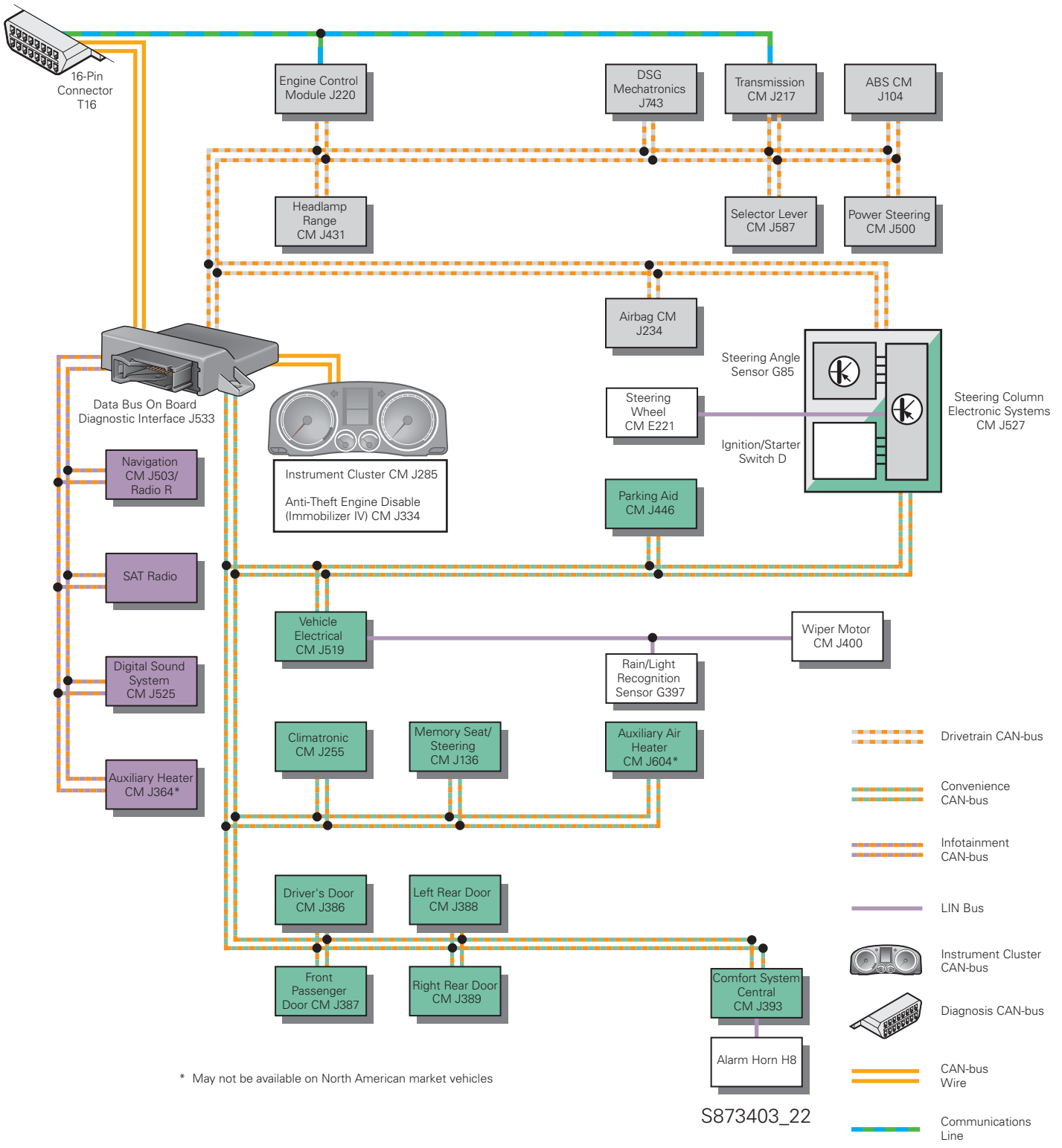

# Introduction

---

## Drivetrain CAN-bus Control Modules

### Control Module Locations

The adjacent illustration shows the control modules of the Drivetrain CAN-bus and their locations.

The data transfer rate is 500 kbit/s. The data is transferred through the CAN high wire (orange/black) and CAN low wire (orange/brown). To ensure reliable communication without conflict or interference, the CAN wires are twisted together.

Motronic Engine Control Module (ECM) J220, under plenum chamber cover



Transmission Control Module (TCM) J217, on left inside wheel housing

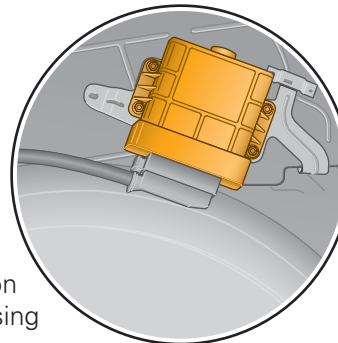

Steering Column Electronic Systems Control Module J527, beneath steering column switch



Data Bus On Board Diagnostic Interface J533, beneath instrument cluster, above accelerator pedal

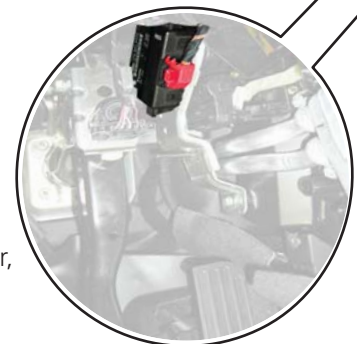

# Introduction

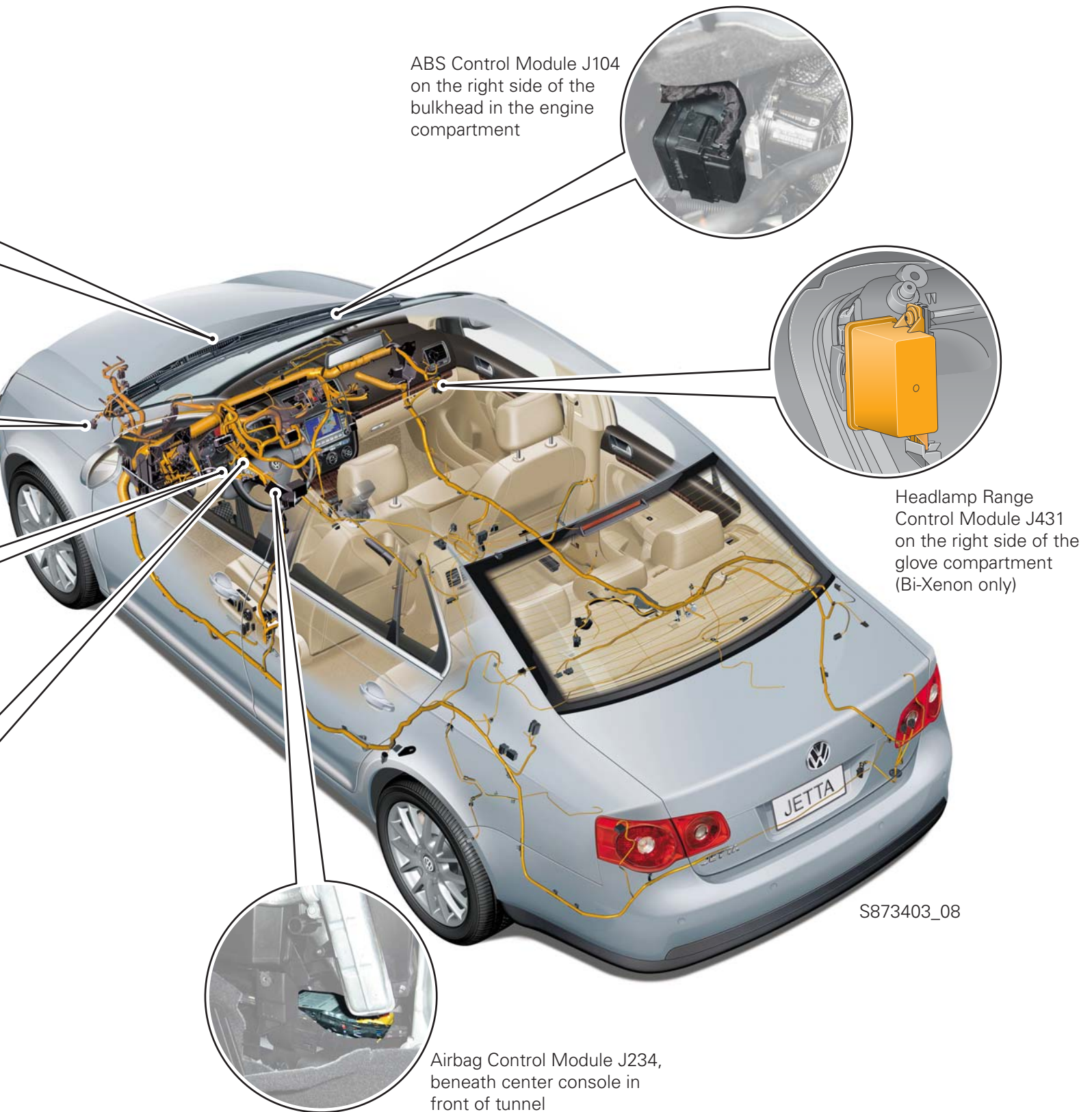

S873403\_08

# Introduction

---

## Convenience CAN-bus Control Modules

### Control Module Locations

The adjacent illustration shows the control modules of the Convenience CAN-bus and their locations.

The data transfer rate is 100 kbit/s. The data is transferred through the CAN high wire (orange/green) and the CAN low wire (orange/brown). To ensure reliable communication without conflict or interference, the CAN wires are twisted together.

Steering Column Electronic Systems Control Module J527, beneath steering column switch



Vehicle Electrical System Control Module J519 under the instrument cluster, on relay carrier

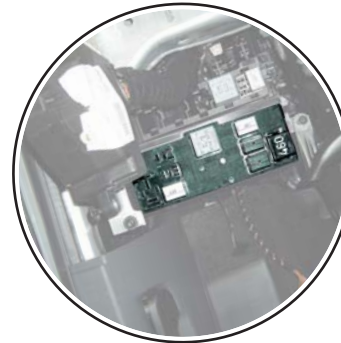

Data Bus On Board Diagnostic Interface J533 beneath the instrument cluster, above accelerator pedal



Climatronic Control Module J255 in center console





# Introduction

Comfort System Central Control Module J393 on right side beneath the instrument cluster, behind glove compartment

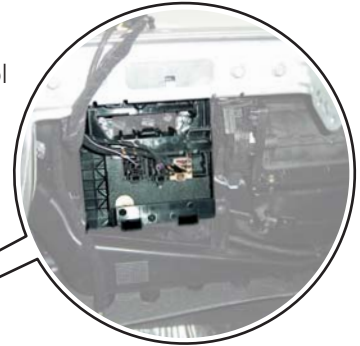

Parking Aid Control Module J446 in rear right side panel



Door Control Modules J386, J387, J388, J389, installed in respective doors



S873403\_09

# Introduction

---

## Infotainment CAN-bus Control Modules

### Control Module Locations

The adjacent illustration shows the control modules of the Infotainment CAN-bus and their locations.

The Infotainment CAN-bus transfer rate is 100 kbit/s. The data is transferred through the CAN-bus high wire (orange/purple) and the CAN-bus low wire (orange/brown). To ensure reliable communication without conflict or interference, the CAN-bus wires are twisted together.



Radio/Navigation Display  
Control Module J503  
(for 2006 model year) or  
Radio R, in center console



CD Changer R41 in center  
console, beneath front  
armrest

# Introduction

Operator Electronics and Telephone Control Module J412 under right front seat, beneath carpet covering on right sill panel (delayed introduction)

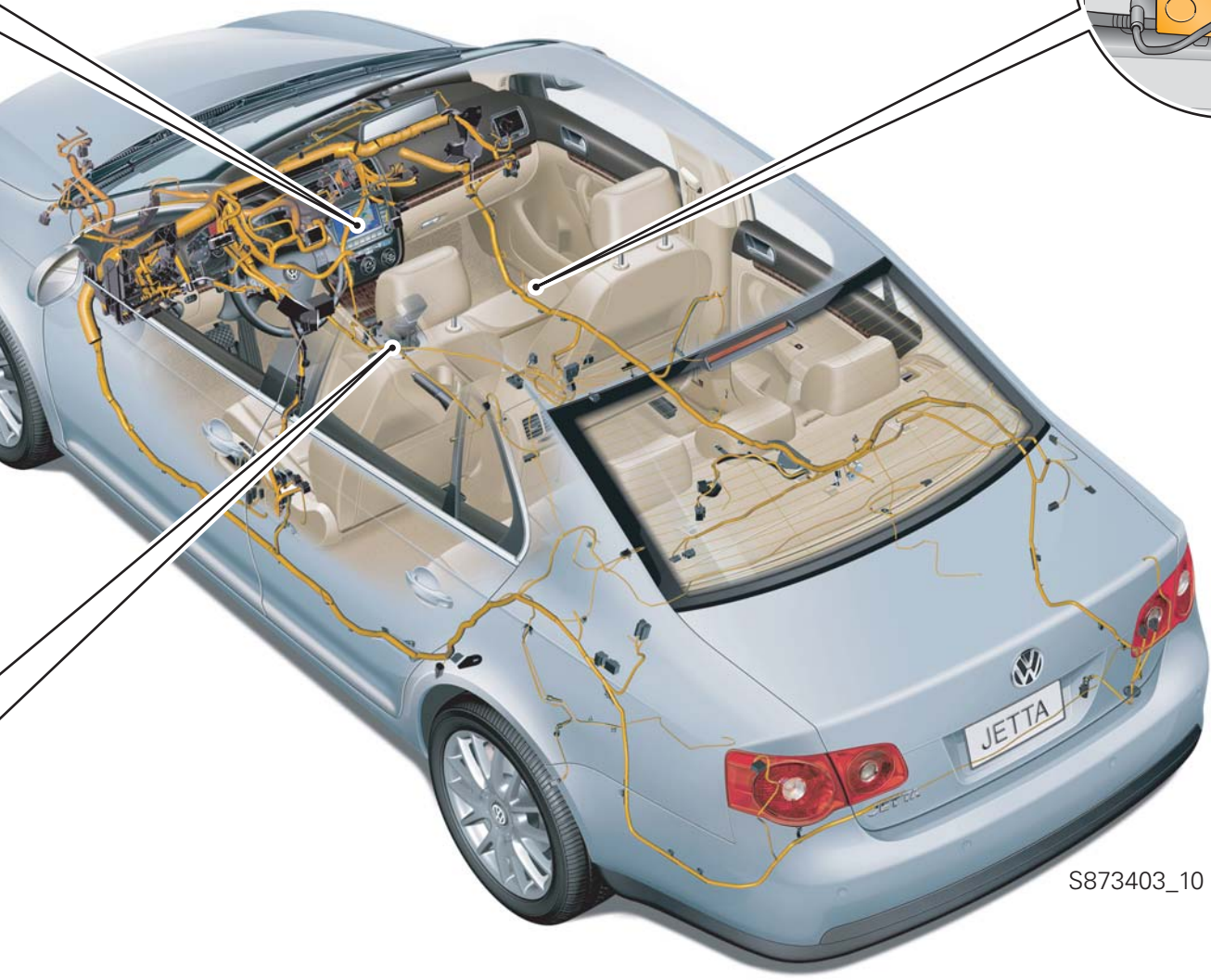
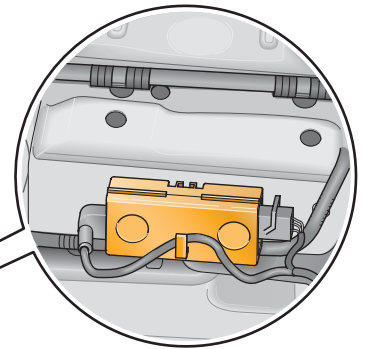

S873403\_10

# Introduction

---

## Instrument Cluster and Diagnosis CAN-bus Control Modules

### Instrument Cluster CAN-bus

Information is exchanged between the Instrument Cluster Control Module J285 and the Data Bus On Board Diagnostic Interface J533 via the instrument cluster CAN-bus. These are the only control modules in this data bus system.

### Diagnosis CAN-bus

The transfer of data between the VAS 5051/5052 scan tool and Data Bus On Board Diagnostic Interface J533 is through the diagnosis CAN-bus.

### Data Transfer Rate

The transfer rate for both CAN-buses is 500 kbit/s.

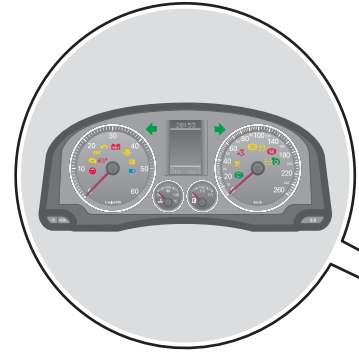

Instrument Cluster Control  
Module J285



16-Pin Connector T16 on left  
side, beneath instrument  
cluster



# Introduction

---

Data Bus On Board Diagnostic  
Interface J533 beneath the  
instrument cluster, above  
accelerator pedal

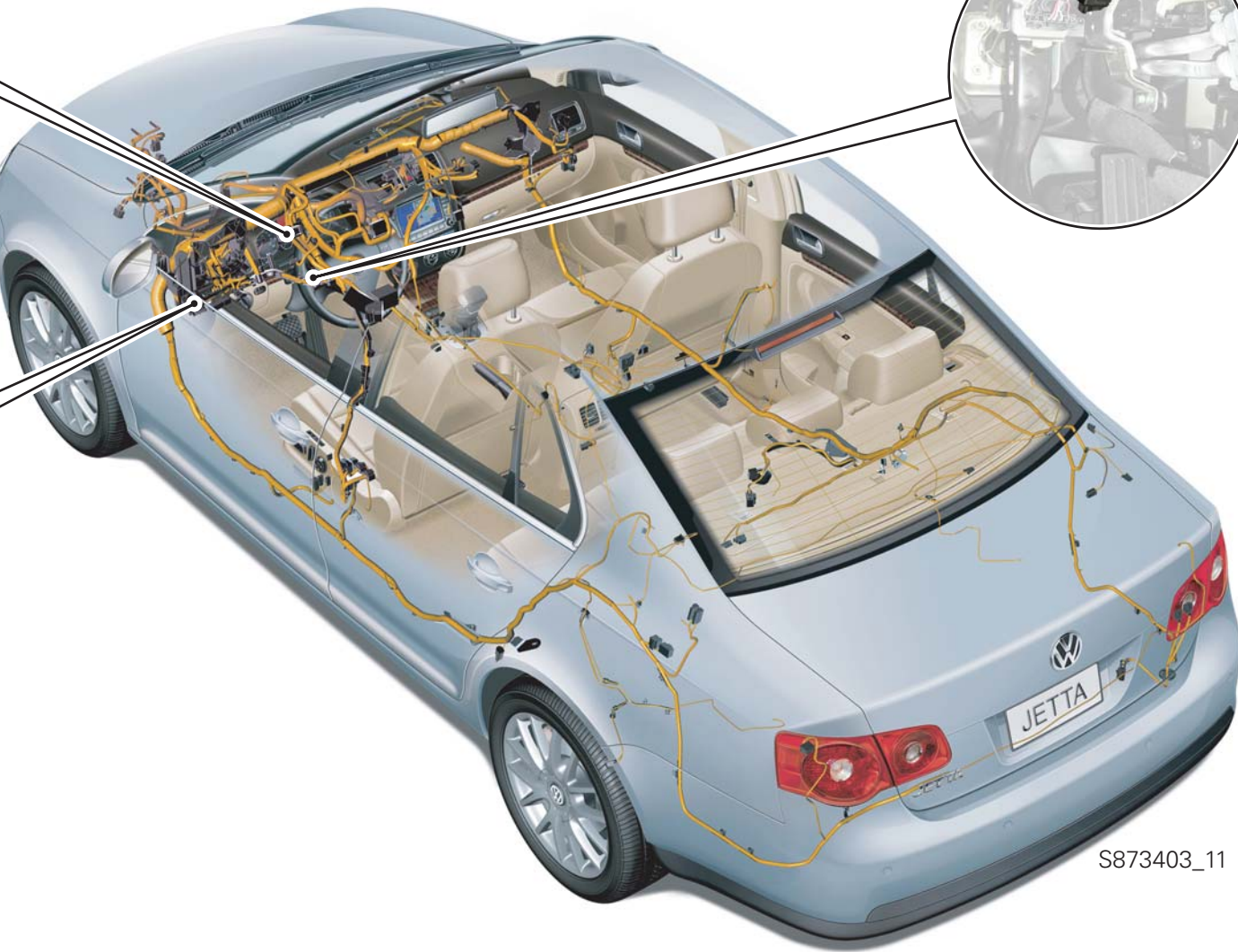
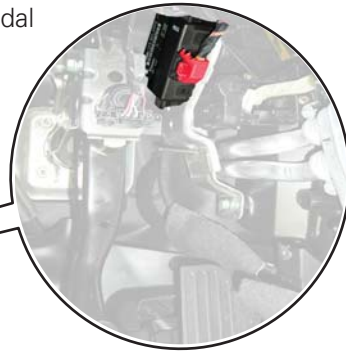

S873403\_11

# LIN Bus

## LIN Bus

The **L**ocal **I**nterconnect **N**etwork (LIN) is a sub-bus system that includes all associated components within a specific area.

- The local sub-system is a cost effective version of the CAN-bus
- The specified component interface allows easy exchange of the connectors
- Bus connection in crash area
- Bus connection in critical safety areas

Components in a LIN bus system include a master control module and up to 16 slave control modules. All communication is initiated by the master control module. Slave control modules cannot communicate independently.

Several independent LIN buses with different functions operate in the vehicle. Information is exchanged between individual bus systems by the master control modules that are connected to the CAN-bus.

## LIN Bus System

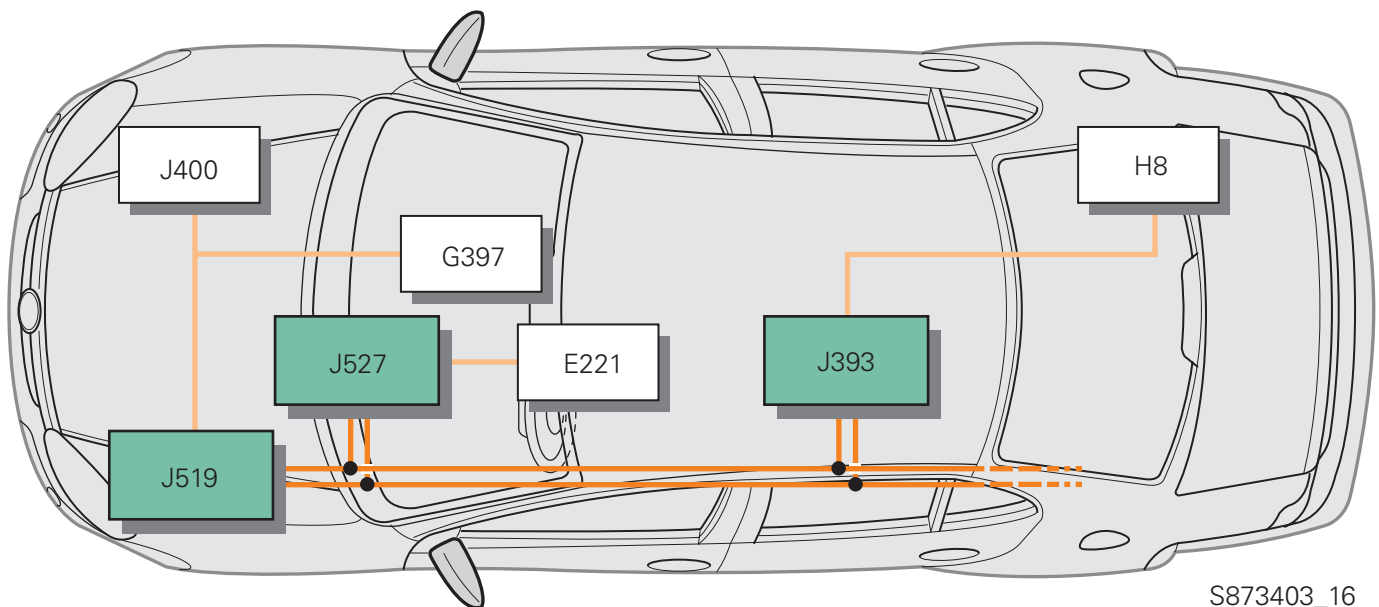

### Key

E221	Control Module in Steering Wheel	J400	Wiper Motor Control Module
G397	Rain/Light Recognition Sensor	J519	Vehicle Electrical System Control Module
H8	Alarm Horn	J527	Steering Column Electronic Systems Control Module
J393	Comfort System Central Control Module		

## Master Control Module

The master control module, which is connected to the CAN-bus, controls the LIN bus system.

### Primary Functions

- Conversion of local data bus information to data format of CAN-bus
- Monitoring of data bus conversion and rate of data transfer
- Control of data transfer cycle
- Transfer of diagnostic data from slave control modules

## Slave Control Module

In the LIN bus system, individual control modules, sensors or actuators can act as slave control modules.

The electronics integrated in the control modules evaluate the information, convert it into digital information and send it, once the request has been made, through the LIN bus to the master control module.

Data commands are sent to the actuators by the master control module through the LIN bus.

After interrogating the master control module, sensors send status information to the master control module and perform a target/reference comparison.

The comfort system central control module below shows the wiring of the LIN and CAN-buses.

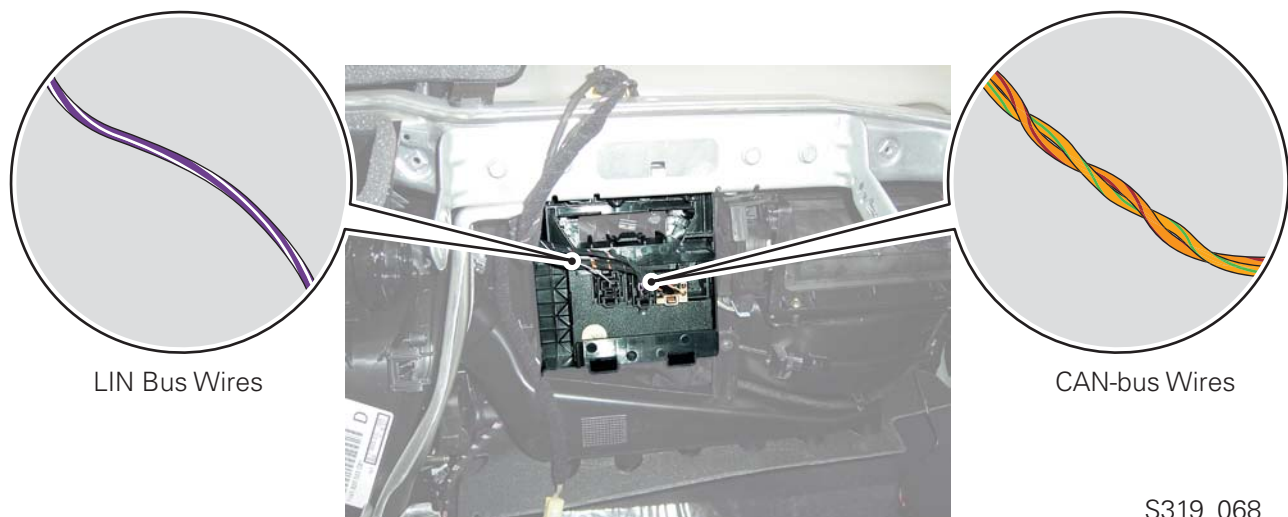

S319\_068

# Power Supply

---

## Electrical Box

Fuses for components in the engine compartment and the vehicle's interior are located in the electrical box.

The distance between the electrical box and the battery is approximately 1.6 ft. (500mm). This allows the battery to function as a high frequency filter between components that are mounted directly on the electrical box.

The increased number of fuses allows the rating of the fuses to be set to the individual components.

## Location

The electrical and back-up fuse boxes are located in a housing within the engine compartment.



S319\_031



# Power Supply

## Electrical Box

In addition to the fuses, the following relays are also located in the electrical box:

- Voltage Supply Terminal 15 (B+) Relay J329
- Power Supply (Terminal 30, B+) Relay J317
- Power Supply Relay (Terminal 50) J682
- Fuel Pump (FP) Relay J17 (except FSI)

## Back-up Fuse Box

The back-up fuse box contains fuses for:

- Alternator
- Electro-mechanical power steering
- Radiator fan
- Power supply from terminal X
- Auxiliary heater
- Terminal 30



S319\_009



S319\_010

# Power Supply

---

## Relay Carrier

### Location

The relay carrier and the supply control module are located on the driverside under the instrument cluster.

### Relay Carrier

Additional relays may be included on the relay carrier depending on equipment options.

On vehicles with power seat adjustment, the automatic safety device (thermal safety) is installed on the relay carrier.

### Supply Control Module Relay Carrier

The following relays are located on the supply control module relay carrier:

- Power supply relay terminal 30G
- Voltage Supply Terminal 15 (B+) Relay J329
- Power Supply Relay 1 (Terminal 75) J680
- Rear Window Defogger Relay J9
- Horn Relay J413
- Dual Washer Pump Relay 1 J729
- Dual Washer Pump Relay 2 J730



S319\_012



S319\_065

## Fuse Box

### Location

The fuse box is located on the driverside of the instrument cluster behind a cover.

### Fuses

The fuse box contains fuses for the electrical components of the vehicle.



Please refer to current service repair information for fuse locations.



S319\_013

# Power Supply

## Data Bus On Board Diagnostic Interface J533

Due to the complexity of vehicle functions, large amounts of data must be exchanged. To ensure optimal data exchange, several data bus systems are required.

The interface function that was previously part of the instrument cluster or supply control module is now performed by J533. It forms the interface for data bus systems that are independent of each other and allows information to be exchanged without conflict or interference.

### Location

J533 is located beneath the instrument cluster, above the accelerator pedal.



S319\_014

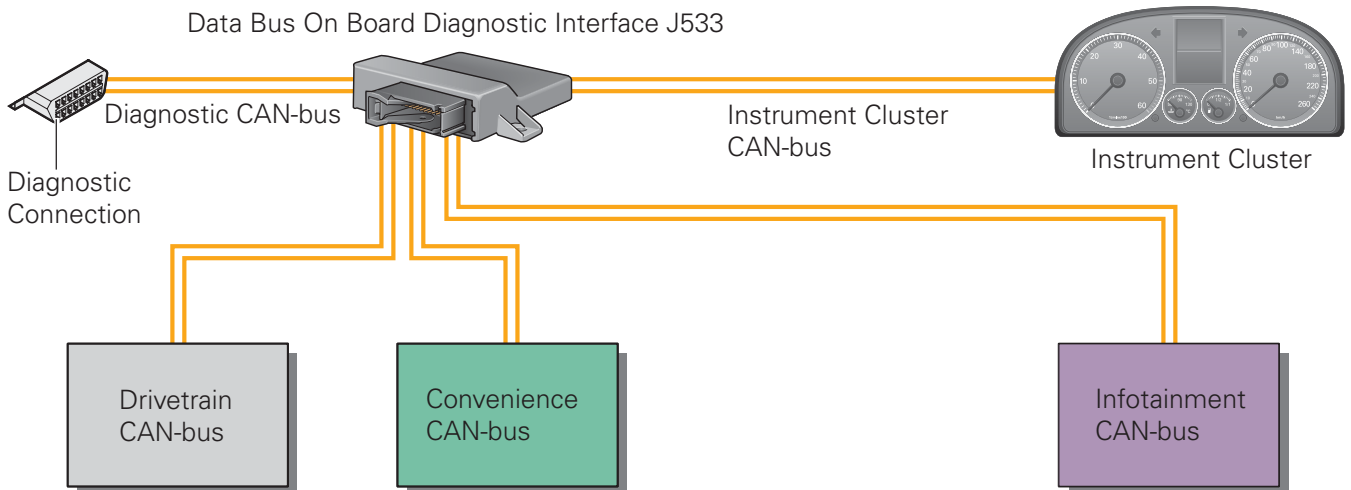

S307\_015

## Master Functions

J533 manages the master functions of the terminal 15 run-on for the Drivetrain CAN-bus along with the sleep and wake-up modes for the data bus systems.

## Terminal 15 Run-On

Some control modules on the CAN-bus must exchange information when terminal 15 is off. When necessary, a message is sent to the CAN-bus to enable the run-on mode. The control modules involved make a connection internally from terminal 30 to terminal 15, allowing them to communicate. The Power Steering Control Module J500, for example, can communicate with the other control modules.

The run-on mode can last between ten seconds and fifteen minutes. The run-on length of time depends on the data being transferred.

The run-on period ends when J533 sends the sleep command.

## Terminal 15 Run-On Control Modules

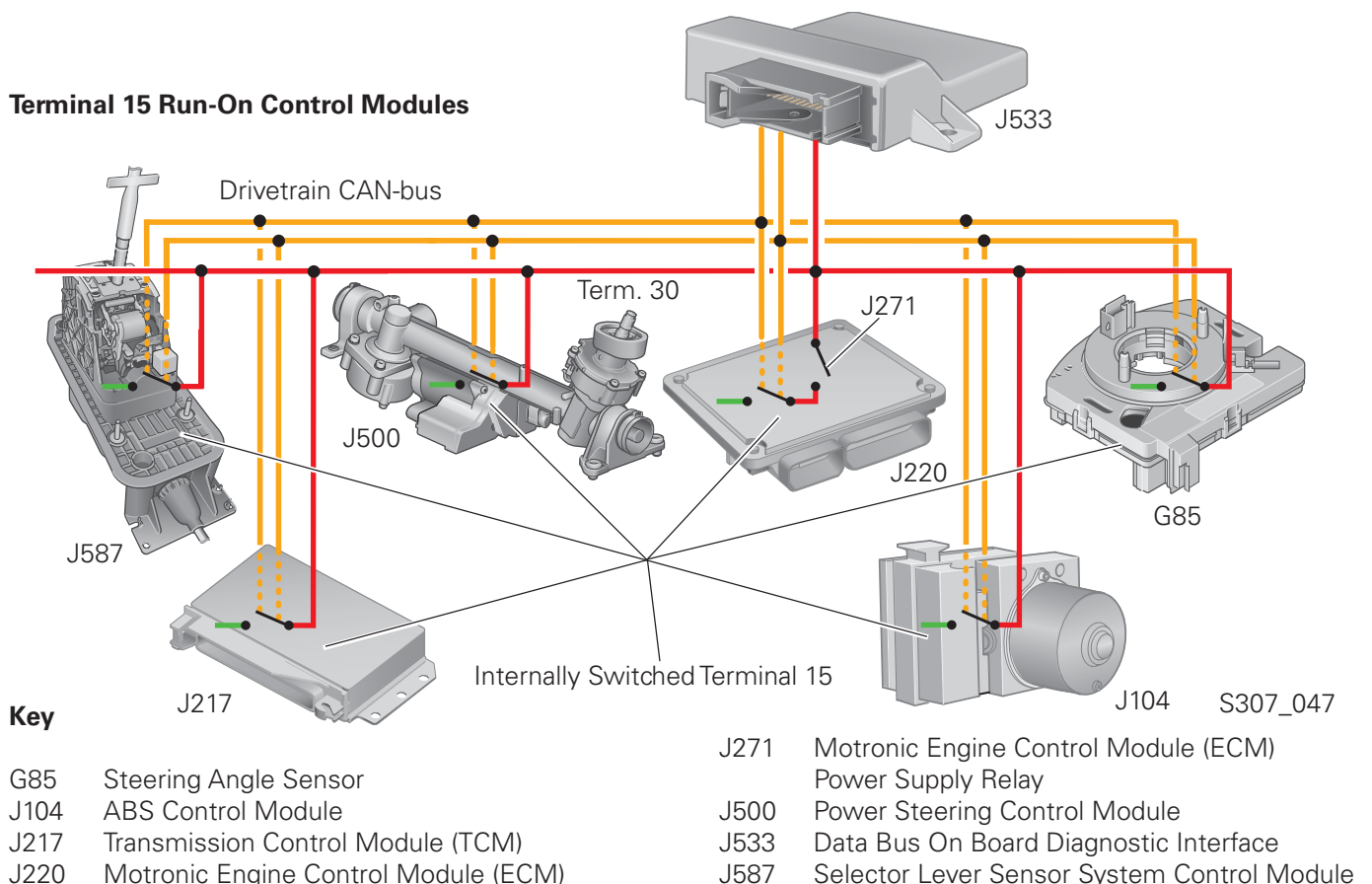

# Power Supply

---

## Data Bus Sleep and Wake-Up Modes

When all of the control modules on the convenience and Infotainment CAN-bus indicate that they are ready for stand-by, a control module gives the signal to 'sleep'. The voltage level of the low signal is 12 volts and 0 volts for the high signal.

A control module also gives the wake-up signal when the data bus requires activation, such as when the doors are unlocked.

The data bus on board diagnostic interface monitors the sleep function.

If the Drivetrain CAN-bus does not go into sleep mode, the Convenience and Infotainment CAN-buses will not go into sleep mode.

If the Convenience CAN-bus does not go into sleep mode, the Infotainment CAN-bus will also not go into sleep mode.

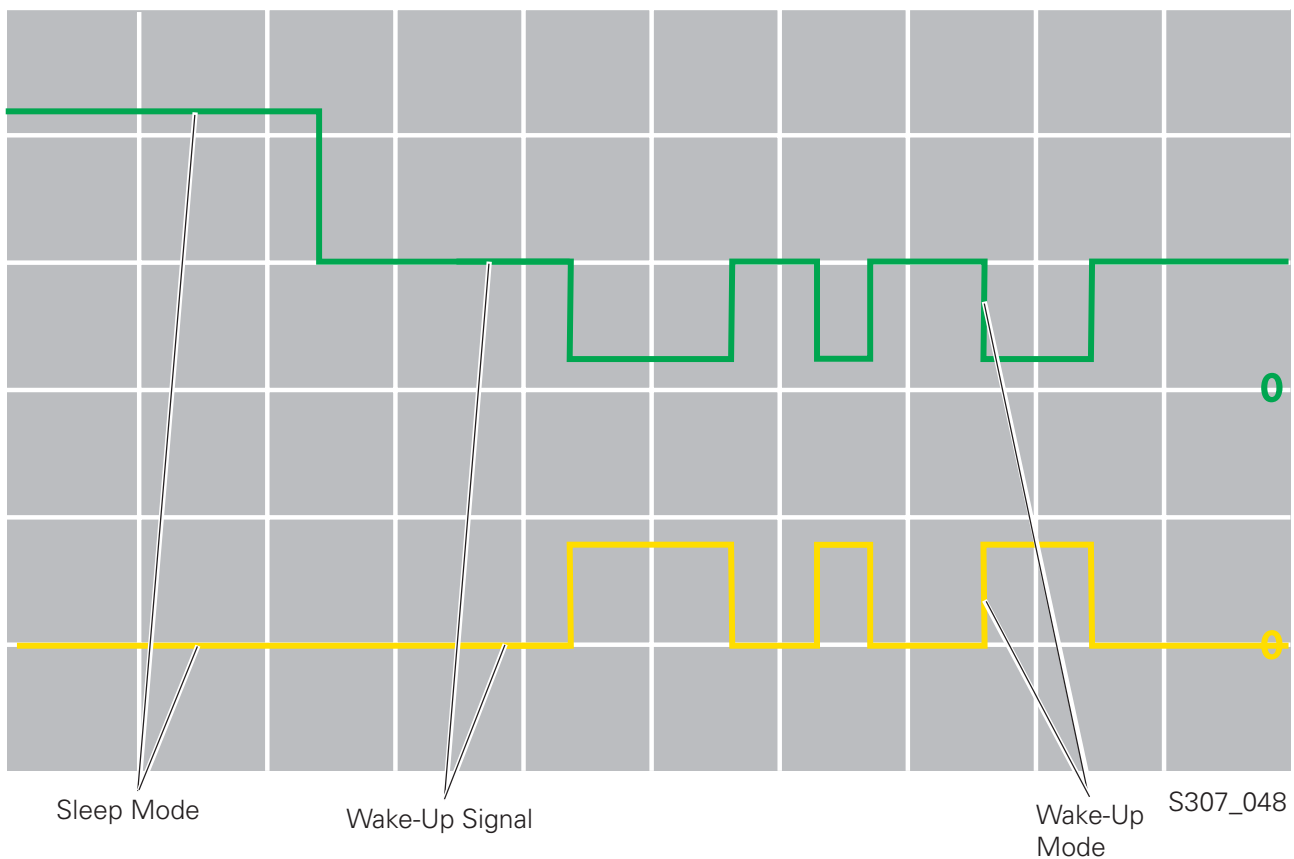

## Transport Mode

During transport to dealerships, power consumption is reduced to protect the battery.

Activating the transport mode isolates the following systems and components:

- Radio
- Radio remote control
- LED indicator in door
- 30 second interior light switch-off delay

The transport mode is switched ON and OFF with the VAS 5051 scan tool through the vehicle's self-diagnosis.

"Tra" shows in the odometer display of the instrument cluster when transport mode is active.

The transport mode is only available during the vehicle's first 93 miles (150km). After reaching this mileage, the J533 automatically switches transport mode OFF. Transport mode cannot be turned ON again after 93 miles (150km) is reached.

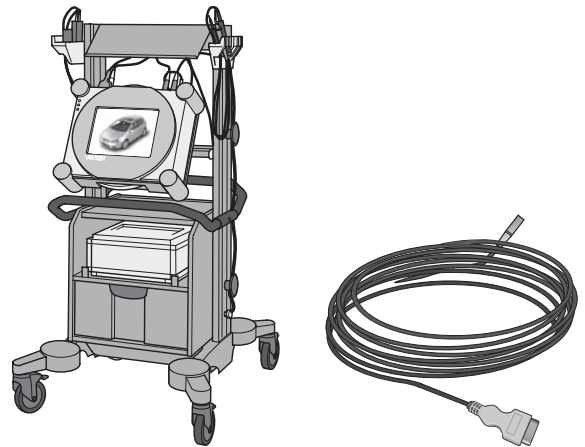

S319\_030



S319\_029

# Power Supply

---

## Vehicle Electrical System Control Module J519

### Location

The Vehicle Electrical System Control Module J519 is located under the instrument cluster. It is attached to the relay carrier.



S319\_065

Vehicle Electrical System Control Module J519

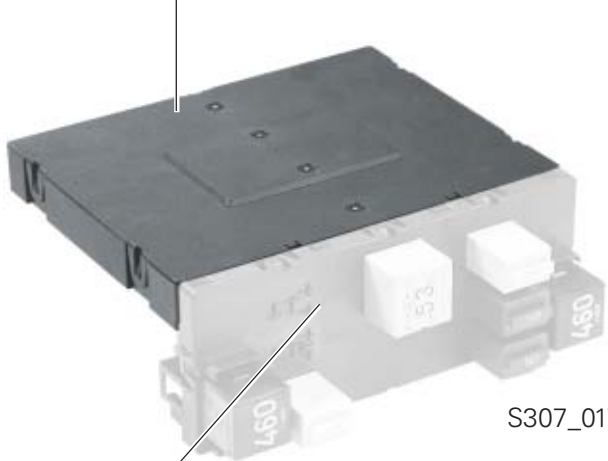

S307\_017

Relay Carrier



## Primary Functions

The vehicle electrical system control module actuates and controls the following functions:

- Exterior light control and monitoring
  - In the event of bulb failure, the relevant warning lamp will light or a text message will display in the instrument cluster
- Convenience lighting:
  - Coming Home
  - Leaving Home
  - Instrument cluster backlight level
- Console lighting
- Windshield wipers
  - Directs CAN-bus signals from the vehicle electrical system control module to the wiper motor control module
- Windshield washer pump
- Turn signal control
- Electric load management shut-off below 11.8 volts

## Secondary Functions

The vehicle electrical system control module also controls the following functions:

- Interior light control
  - Terminal 30G determines what voltage is supplied to the interior lights.
- Heated rear window
  - Via the heated rear window button
- Terminal activation
  - Terminal 75x is activated via an 'X' contact relief relay.
  - Terminal 15 is activated via voltage supply terminal 15 (B+) relay in the electrical box.
  - Terminal 50 is activated via power supply relay (terminal 50) in the electrical box.
- Fuel pump readiness
  - The electric fuel pump is supplied with power when the driver's door is opened. After the engine has started, power is supplied from the Motronic engine control module.

# Power Supply

---

## Electrical Load Management

The electrical load management makes sure that there is enough reserve electrical power in the battery to start the engine.

If necessary, convenience system electrical devices are deactivated without compromising safety requirements.

The vehicle electrical system control module monitors the engine speed, the battery voltage and the alternator load through the DF signal (dynamo field).

From this information and from information about which devices are on for short periods, the vehicle electrical system control module evaluates the power supply load state.

Based on this evaluation, the vehicle electrical system control module can increase engine speed via the engine control module or deactivate convenience devices.

Three load management operating modes are possible.

## Operating Mode 1

Terminal 15 ON and alternator active

### Management Activities

At a battery voltage below 12.7 volts, the vehicle electrical system control module commands an increase in the engine idle speed.

At a battery voltage below 12.2 volts, the following electrical devices are turned OFF:

- Heated seats
- Heated windshield
- Heated exterior mirrors
- Steering wheel heating
- Footwell lighting
- Interior door handle lights
- Reduction and deactivation of Climatronic
- Warning and deactivation of Infotainment

## Operating Mode 2

Terminal 15 ON and alternator inactive

### Management Activity

At a battery voltage below 12.2 volts, the following electrical devices are turned OFF:

- Reduction and deactivation of air conditioning
- Footwell lighting
- Interior door handle lights
- Entry/exit lights
- Leaving home
- Warning and deactivation of Infotainment

## Operating Mode 3

Terminal 15 OFF and alternator inactive

### Management Activity

At a battery voltage below 11.8 volts, the following electrical devices are turned OFF:

- Interior lights
- Footwell lighting
- Inner door handle lights
- Entry/exit lights
- Leaving home
- Infotainment, e.g. radio

The primary differences of component or system deactivation in the various operating modes is the order in which they are deactivated.

Operating mode 3 deactivates several electrical devices at once.

Deactivation is cancelled when the conditions for deactivation are no longer present.



When deactivation occurs, notification appears in the instrument cluster display. A fault entry is also logged in the electrical system control module fault memory.

# Power Supply

---

## Exterior Light Control

### Headlights

The twin headlights with low and high beam reflectors are equipped with H7 halogen bulbs as standard equipment.

To improve visibility for other drivers, the turn signals are located beneath the headlights, providing a well-balanced distribution of light from the turn signal.

On some vehicles, a combination of the Bi-Xenon module, a high beam reflector, and H7 bulbs is an option.

Bi-Xenon equipped vehicles are also enhanced with a washer system and dynamic headlight range control.



S873403\_28

Turn Signal Light  
High Beam Headlight  
Low Beam Headlight

### Bulb Replacement with One-Touch-System

The One-Touch-System allows both the cover and H7 bulbs to be removed with a twist motion. A guide assists with installation.



S319\_034

## Rear Lights

Available for the first time on the new Jetta are the split rear lights with round elements.

The rear light unit, integrated into the side panel, provides the tail, brake, and turn signal light functions.

An additional reverse light is located in the trunk deck.

An auxiliary brake light is located in the rear window. Turn signals in the exterior mirrors complement the front and rear turn signals. They provide additional visual information to other drivers.

## Light Switch

The rotary light switch is a semi-conductor module that sends switch position information to the vehicle electrical system control module.

The vehicle electrical system control module controls all exterior light functions.

## Advantages

- Elimination of voltage spikes in the rotary light switch increases bulb life

## Special Functions

- All bulbs are monitored for failure
- The bulb monitoring system information is displayed in the instrument cluster



# Power Supply

---

## Convenience Lighting

### Coming Home

When occupants exit the vehicle and close the doors, including the trunk, the vehicle surround lighting is activated for a short time.

### Leaving Home

After the vehicle has been unlocked using the remote control key, the surround lighting is turned ON for a short time.



After the convenience lighting has turned OFF or been interrupted, the Coming Home function cannot be reactivated until the ignition is switched ON.

If the rotary light switch is in the “low beam position,” the lights are switched OFF completely once the lighting period has elapsed.

If the rotary light switch is in the “side light position,” the side light bulbs remain ON for an additional time after the surround lighting has turned OFF.

# Power Supply

The following lights are switched ON by the Coming Home and Leaving Home functions:

- Front side lights
- Low beam headlights
- Taillights
- License plate light



Activation or deactivation of the coming and leaving home functions and the lighting periods are set in the instrument cluster by accessing the "Light & Vision" MFI personalization menu.



S873403\_28  
High Beam Headlight  
Running Light  
Low Beam Headlight  
Side Light



S873403\_29  
Taillight

# Power Supply

---

## Windshield Wiper System

### Wiper Operation

The wiper system consists of a single motor with mechanical connections to the wiper arms.

The selected position of the Windshield Wiper Switch E is sent to the Steering Column Electronic Systems Control Module J527 and relayed through the Convenience CAN-bus to the Vehicle Electrical System Control Module J519. The vehicle electrical system control module sends information about the selected wiper position through the LIN bus to the Wiper Motor Control Module J400, which controls wiper action.

On vehicles with rain and light sensors, the wiper frequency is calculated in the rain sensor mode and sent to the wiper motor control module.

During intermittent operation, wiper movement is speed dependent and varies between 2 and 24 seconds.

The wiper control system can detect an obstruction and react according to the degree of resistance. The wipers will try to move the obstacle out of the way. If it still has not been removed after the fifth attempt, the wipers will stay in that position. Activation of the wipers after the obstacle has been removed is accomplished by turning the switch ON.

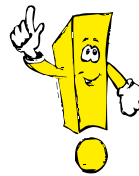

Instead of rotating 360°, the wiper assembly reverses every 150°. This allows a much smaller space for wiper linkage.

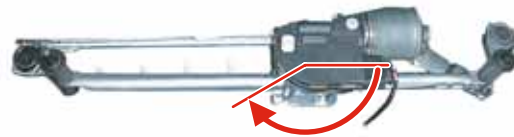

S319\_069



## Overview of Windshield Wiper System

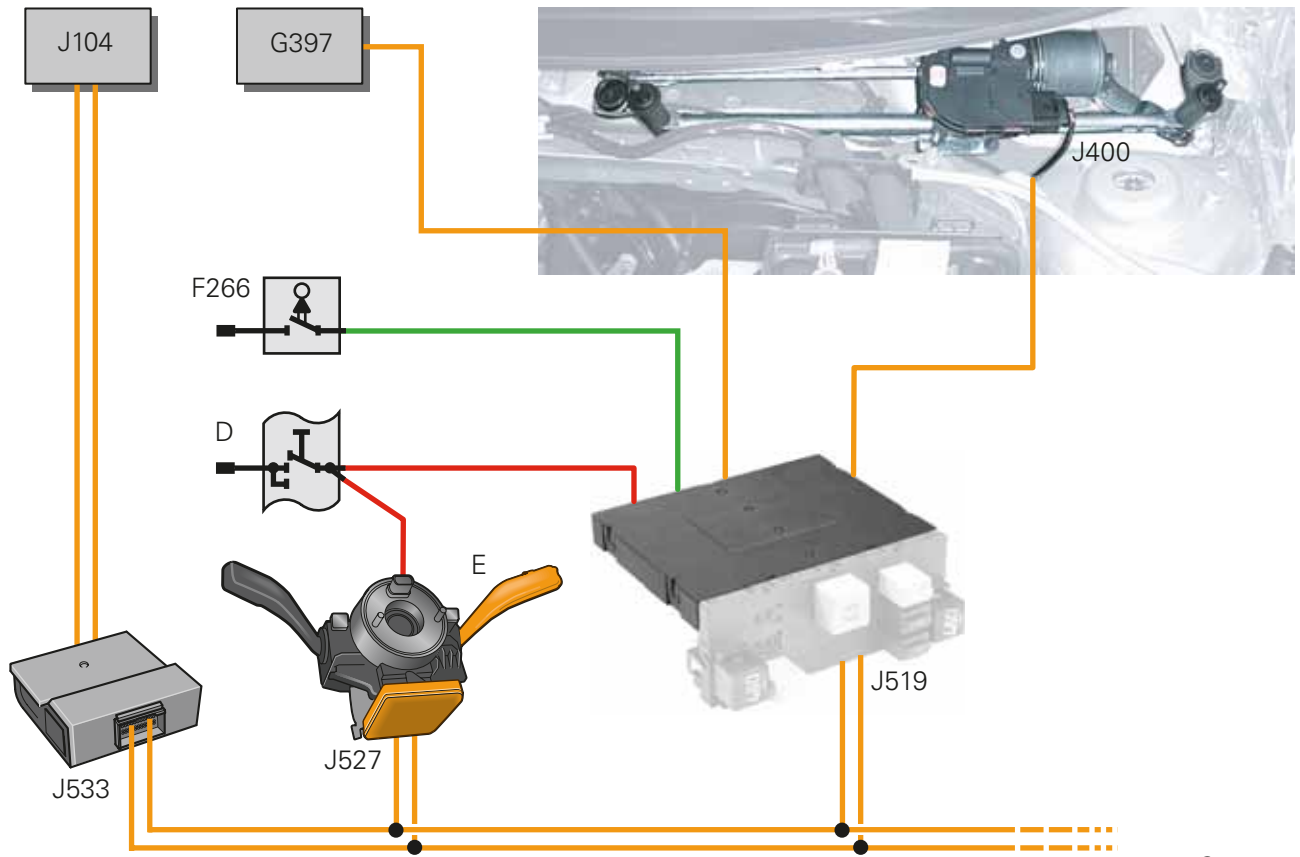

S319\_016

### Key

D	Ignition/Starter Switch	J400	Wiper Motor Control Module
E	Windshield Wiper Switch	J519	Vehicle Electrical System Control Module
F266	Front Hood Switch	J527	Steering Column Electronic Systems Control Module
G397	Rain/Light Recognition Sensor	J533	Data Bus On Board Diagnostic Interface
J104	ABS Control Module		

# Power Supply

---

## Service/Winter Position

Moving the wiper switch to the “tip wiping” position (down) within 10 seconds of switching OFF the ignition causes the wipers to move to the end position of wiper travel known as the service/winter position.

When the wipers are in the service/winter position, the wiper blades can be easily replaced or the wiper arms can be lifted to prevent the rubber from freezing to the windshield.

The wipers will revert to the rest position when the windshield wiper switch is turned OFF and ON with the ignition ON or if the vehicle reaches a speed of 1.2 mph (two km/h).



When the vehicle is parked and the hood is open, the wipers will not operate.

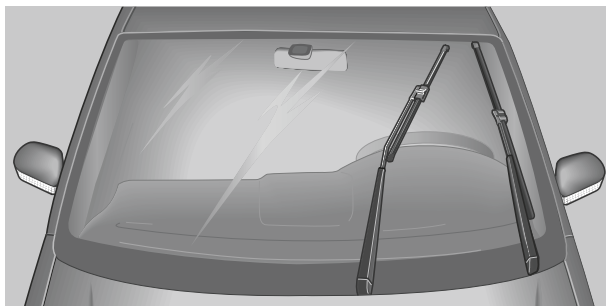

S319\_015

## Headlight Washer System

The headlight washer system (with optional Bi-Xenon headlamps) is activated by the vehicle electrical system control module as part of the “wash/wipe” function.

### Activation Conditions

- Ignition ON
- Side, low beam or assistant driving lights ON
- Steering column switch in “wash/wipe” position

### Headlight Wash Cycle

- Runs every fourth time the “wash/wipe” function is activated by the control module

## Windshield Washer Quick Disconnect/Lock System

### Features

- Easy removal/assembly
- Improved longevity
- Improved anti-crimp and freeze protection
- Convoluted-type tubes

The quick disconnect/lock system for the windshield washer system is a new feature of the Jetta.

With this system, the windshield washer hoses are convoluted tubes that minimize the chance of crimping.

The tube connections to the windshield washer pump and washer jets are secured by clips.

To disassemble, pull the clip outward by hand to allow hose removal.

To install, press the hose onto the opening until the clip engages automatically.

**Engaged**

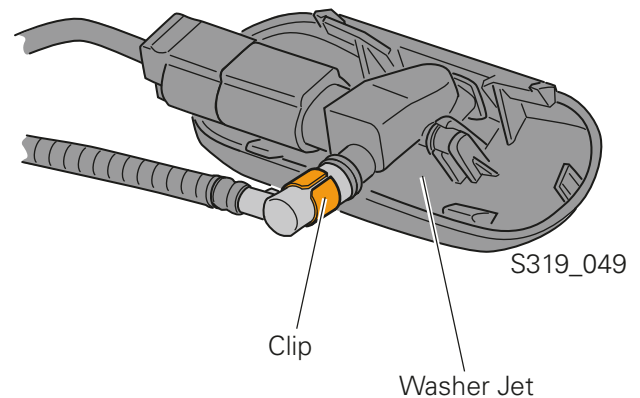

**Disengaged**

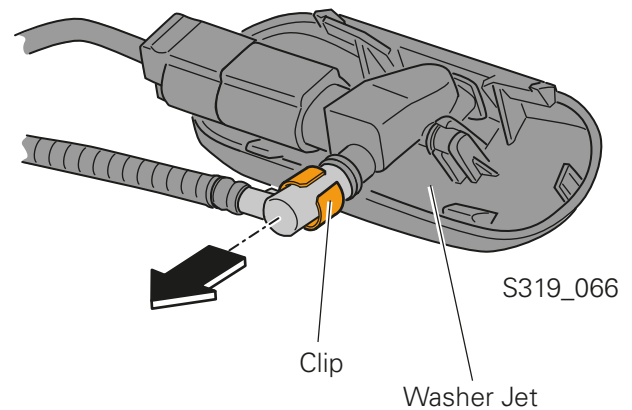

# Power Supply

---

## Instrument Cluster Control Module J285

J285 receives information through the Data Bus On Board Diagnostic Interface J533 and the instrument cluster CAN-bus.

Additional external sensor signals that are sent to the instrument cluster by separate wiring:

- Oil Pressure Switch F1
- Brake Fluid Level Warning Switch F34
- Outside Air Temperature Sensor G17
- Engine Coolant Level (ECL) Sensor G32
- Windshield Washer Fluid Level Sensor G33
- Left Front Brake Pad Wear Sensor G34
- Fuel Pump (FP) Control Module J538

### Diagnosis

Diagnosis of J285 performed using the diagnosis tester VAS 5051/5052 through the CAN-bus.

J285 is also capable of self-monitoring. If a fault occurs, the letters "def" will appear in the instrument cluster display.

## Anti-Theft Immobilizer Control Module J362

### Immobilizer IV

The Anti-Theft Immobilizer Control Module J362 is integrated into the instrument cluster control module. With the ignition switched ON, it enables or disables specific vehicle functions.

The only way to communicate with the Immobilizer is by using Guided Fault Finding in the VAS 5051 scan tool.

### Active Immobilizer

If the Immobilizer is active, it emits an audible sound and a warning light illuminates in the tachometer display.

Adaption channels and stored faults are handled separately.

The Immobilizer address is word 25 for diagnosis.

Immobilizer Light

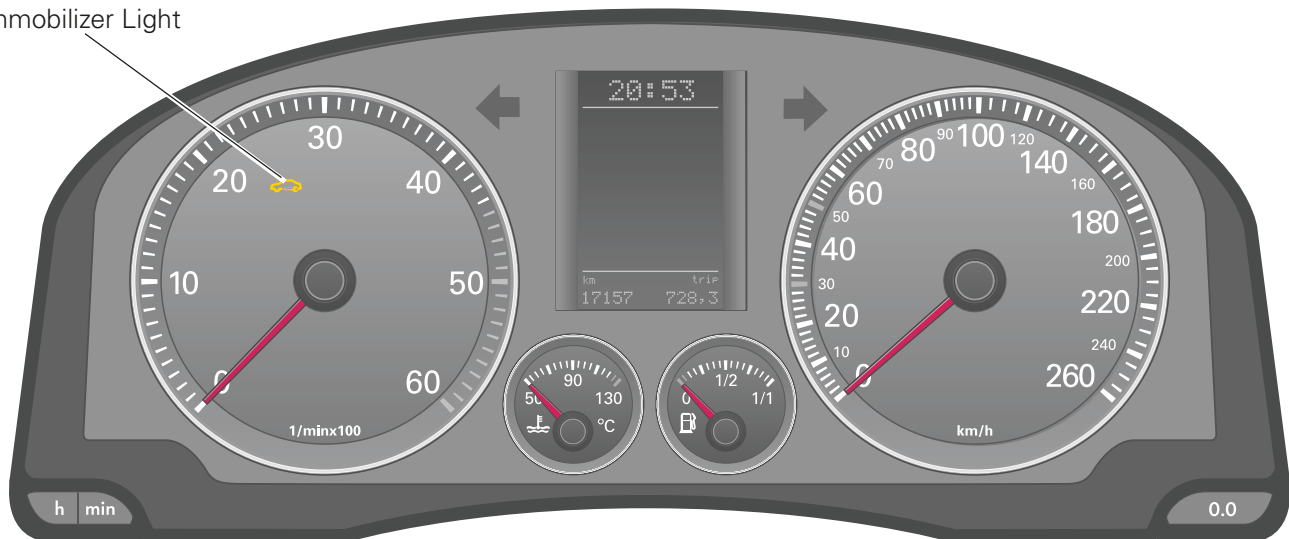

S319\_051



Diagnosis of the Immobilizer control module is performed via the "Guided Fault Finding" function.

# Power Supply

## Warning Lights in the Instrument Cluster

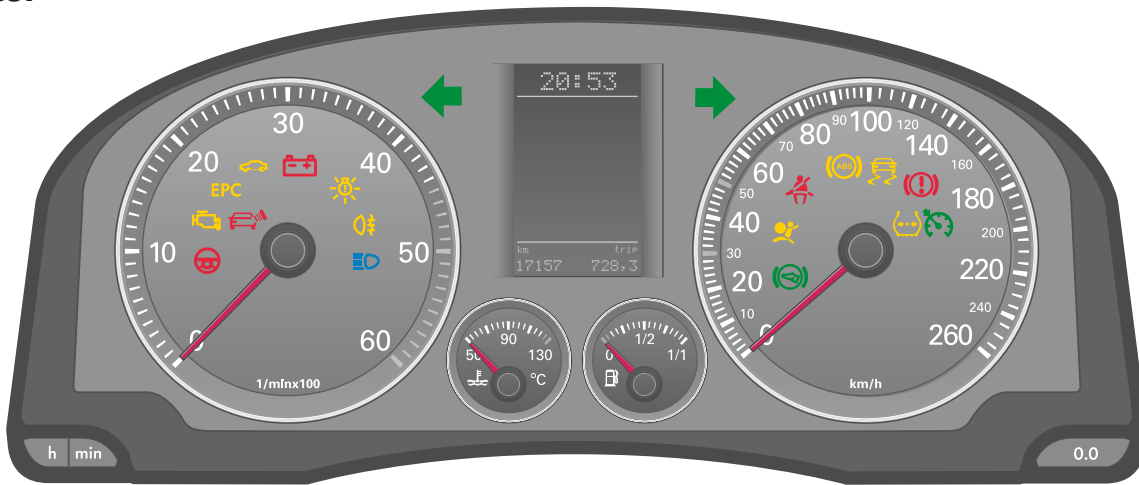



















S319\_017

Symbol	Warning Light	Indicator	Warning Message or Description
	Airbag	Light	Airbag fault Airbag belt tensioner deactivated
	Anti-lock braking system (ABS)	Light	ABS
	Brake pad wear indicator	MFI Display	Check brake lining 1 x audible warning
	Low brake fluid level	Flashing	Stop-Brake fluid Operating instructions 3 x audible warnings
	Preglow period (diesel engines only)	Light	
<b>EPC</b>	Electronic Power Control (EPC)	Light	
	Oil pressure warning	MFI Display	Stop-Oil pressure turn engine OFF See operating instruction 3 x audible warnings
	Electronic power steering (EPS)	Light	Low priority fault yellow High priority fault red
	Electronic brake pressure distribution (EBD)	Flashing	3 x audible warnings
	Parking brake system	Light	Handbrake applied 1 x audible warning
	Electronic stabilization program (ESP)	Light	



# Power Supply

Symbol	Warning Light	Indicator	Warning Message or Description
	Left turn signal	Light	Audible warning
	Right turn signal	Light	Audible warning
	High beam headlights	Light	
	Cruise control system (CCS)	Light	
	Bulb blown/driving light defective	Light	Example–Front right low beam headlight defective
	Trunk/door open	MFI Display	Trunk open 1 x audible warning
	Fuel reserve low	MFI Display	Replenish fuel 1 x audible warning
	Coolant level low/coolant temperature high	MFI Display	Stop–check coolant Operating instructions 3 x audible warnings
	Alternator low voltage output	Light	
	Engine check Onboard diagnosis (OBD)	Light	Engine fault service Exhaust emissions service
	Hood open	Light	Door warning, hood, 1 x audible warning vehicle moving less than 3.7 mph (6 km/h)
	Rear fog light	Light	
	Oil level low	Light	Check oil level Oil sensor service 1 x audible warning
	Tire pressure low	Light	1 x audible warning
	Shift lock	Light	
	Seat belt	Light	Please use seatbelt Belt warning alarm
	Washer fluid low	MFI Display	Add washer fluid 1 x audible warning
	Anti-theft Immobilizer	Flashing	Immobilizer active 1 x audible warning

# Power Supply

---

## Comfort System Central Control Module J393

### Location

The Comfort System Central Control Module J393 is located beneath the instrument cluster, on the passenger side behind the glove compartment.

### Functions

- Control of central locking
- Activation of rear door locks
- Activation of fuel tank door release
- Activation of trunk release
- Activation of anti-theft engine disable or Immobilizer alarm system via LIN bus

In earlier models, the mirrors were controlled via the comfort system central control module. The door control modules now control all systems in the door area, including the mirrors. This reduces electrical wiring.

J393 is the master control module in the LIN bus. This control module initiates data transfer for the anti-theft engine disable and Immobilizer alarm systems. Included in the anti-theft engine disable and Immobilizer alarm systems are interior monitoring sensors, smart alarms and the vehicle inclination sensor.

Depending on the model and options, some electrical components and connectors may not be used in the comfort system central control module.



S319\_064

# Convenience and Safety Systems

## Personalization

The user-based settings for various functions in the Convenience and Infotainment CAN-bus systems are selected by pressing the controls on the right windshield wiper stack while observing the MFI Menu options in the instrument cluster display. Selections are stored in the control module, which controls all functions.

Data transfers between the instrument cluster control module and associated control modules is managed by the CAN-bus.

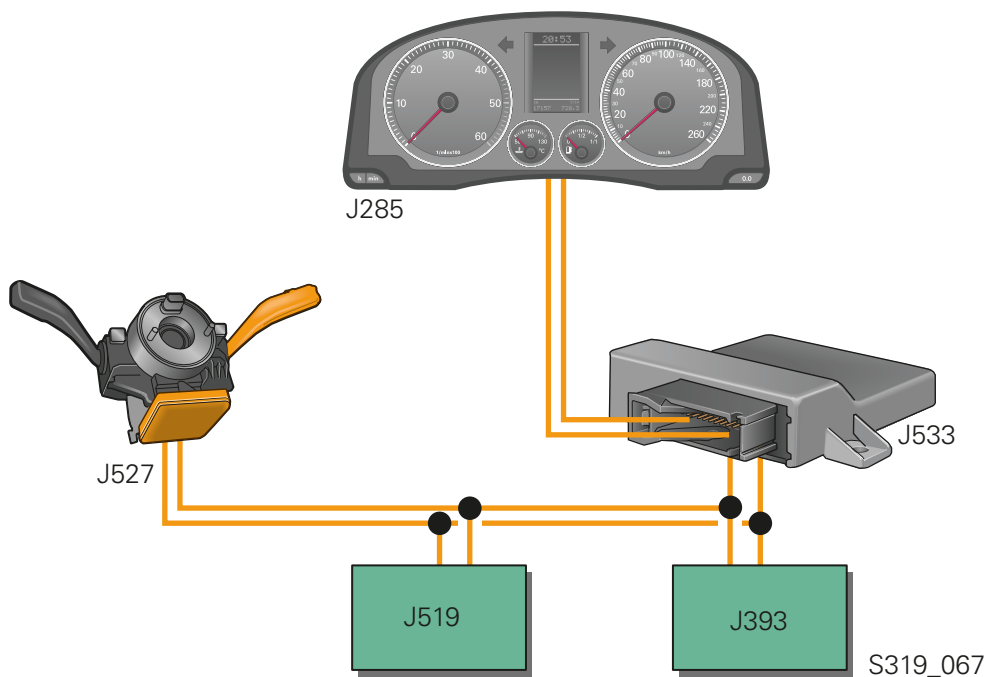

### Key

- J285 Instrument Cluster Control Module
- J393 Comfort System Central Control Module
- J519 Vehicle Electrical System Control Module
- J527 Steering Column Electronic Systems Control Module
- J533 Data Bus On Board Diagnostic Interface

# Convenience and Safety Systems

## Accessing Programming Menus

The following procedure allows access to the new Jetta's convenience options using the multi-function indicator (MFI) switch lever.

To access the convenience menu:

1. Press and hold the Up/Down Toggle Switch in the "UP" or "DOWN" position for two seconds.
2. Use the Up/Down Toggle Switch to highlight "Setup" and then press the OK/Reset switch to select it.
3. Toggle to "Convenience" and then press the OK/reset switch to select it. From there, adjust the convenience settings.



For detailed information on programming, please refer to the operating instructions in the vehicle owner's manual.



OK/Reset Switch  
Up/Down Toggle Switch  
Multi-Function Indicator (MFI) Switch Lever



S873403\_25



S873403\_26

# Convenience and Safety Systems

## Radios

### RCD 300 Radio System (Base Radio)

The RCD 300 radio is a standard radio system. It has the following features:

- Two or four loudspeaker channels (each 20 W)
- RDS FM/AM
- Display of stored stations and RDS names
- MP3 compatible
- FM-2 tuner
- Control by multi-function steering wheel (MFS) and multi-function display (MFD)
- Integrated single CD drive
- Controls for external 6 disc CD changer
- Telephone control (hands-free operation)
- GALA
- Self-diagnosis including speaker diagnosis
- Transport Mode

### Radio RCD 500 (Premium 7)

The top radio for the new Jetta is the RCD 500 with the following functions:

- Four speaker channels (20 W each)
- RDS FM/AM Radio (AM without LW)
- Display of stored stations with RDS names
- MP3 compatible
- FM 2 diversity tuner
- Operation through multi-function steering wheel and multi-function display
- Integrated 6 disc CD changer
- Controls for external 6 disc CD changer
- GALA
- Model-specific sound adjustment
- SAT Optional Satellite Radio
- Self-diagnosis including speaker diagnosis
- Transport mode
- Optional external sound amplifier



S873403\_30



S873403\_27

# Convenience and Safety Systems

---

## **MFD 2 Radio Navigation System (Delayed Introduction)**

A radio system with an integrated navigation system will be available for the 2006 model year. Features include:

- Multi-color display (MCD)
- DVD-based system
- Four speaker channels (20 W each)
- RDS FM/AM Radio (AM without LW)
- Display of stored stations with RDS names
- External diversity tuner
- Operation via multi-function steering wheel and multi-function display
- Controls for external 6 disc CD changer
- GALA
- Self-diagnosis including speaker diagnosis



S873403\_32



# Convenience and Safety Systems

## Antennas

Jettas are equipped with different antenna systems depending on the options selected. Rear window antennas are not serviceable.

### Radio RCD 300/RCD 500

The RCD 300 and RCD 500 radios are equipped with an internal diversity tuner (automatic selection between antennas). An external diversity tuner is not required.

Two rear window antennas are connected to the radio. The radio automatically selects the antenna with the strongest signal.

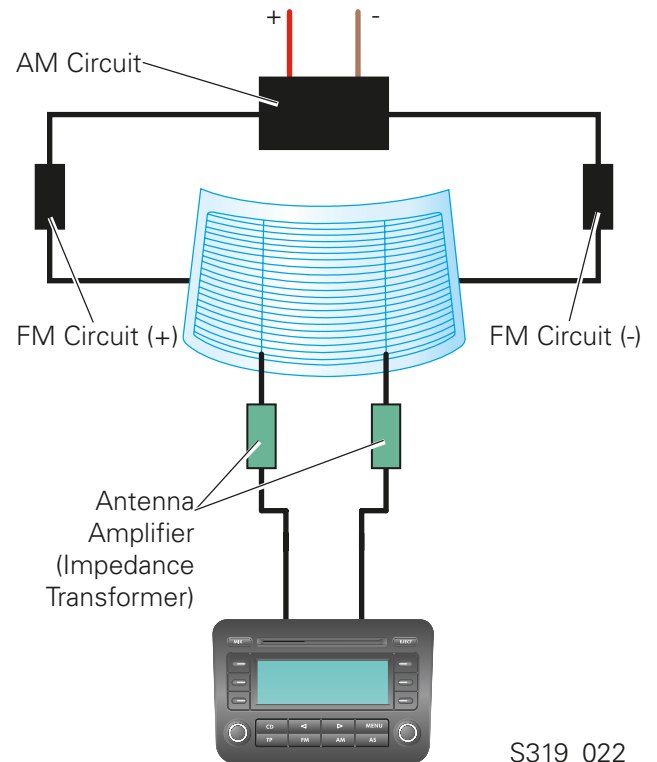

S319\_022

# Convenience and Safety Systems

## MFD 2 Radio Navigation System

The MFD 2 radio navigation system does not use an internal diversity tuner. The MFD 2 uses an external tuner and two rear window antennas.

The MFD 2 radio navigation system uses a shark-fin type roof antenna.

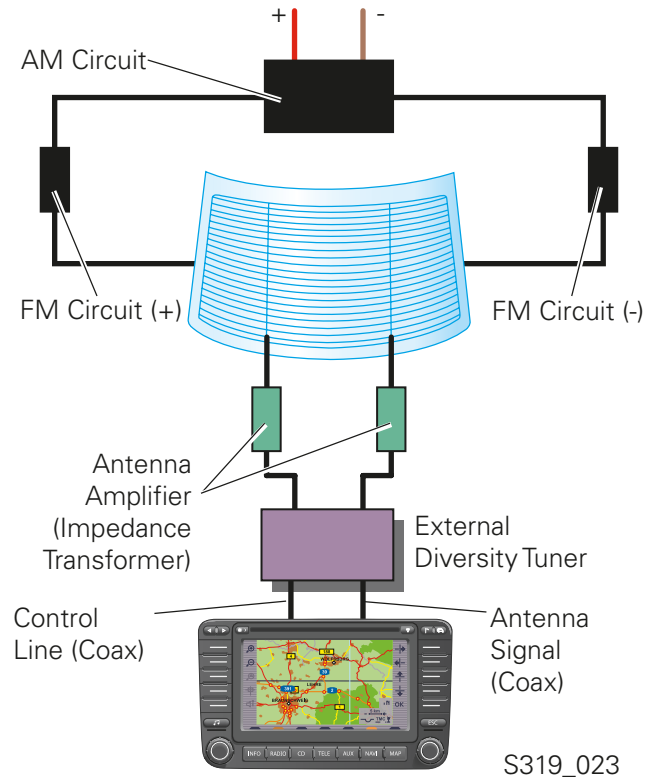

# Convenience and Safety Systems

## Multi-Function Steering Wheel

### System Overview

The multi-function steering wheel communicates with the steering column switch module through a LIN bus.

Communication from the steering column electronic systems control module to the on board diagnostic interface is through the CAN-bus, which passes these signals to the desired control modules.

The multi-function steering wheel becomes active when the ignition is turned ON.

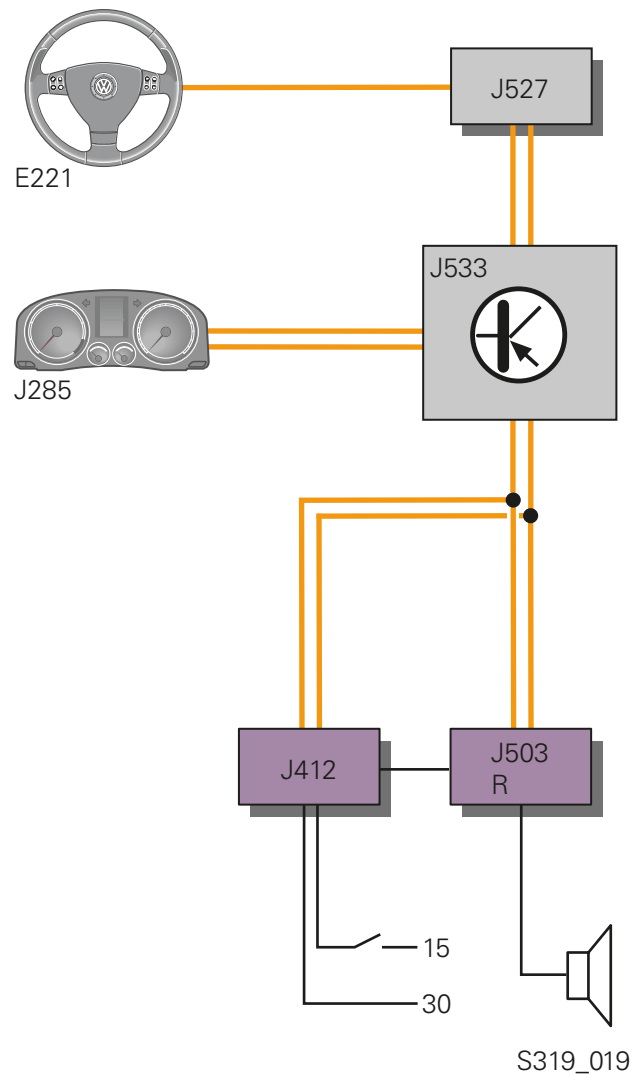

### Key

E221	Control Module in Steering Wheel
J285	Instrument Cluster Control Module
J412	Operating Electronics and Telephone Control Module
J503	Radio/Navigation Display Control Module
J527	Steering Column Electronic Systems Control Module
J533	Data Bus On Board Diagnostic Interface
R	Radio
R66	Telephone/Navigation System (GPS)/ Auxiliary Heater Antenna

# Convenience and Safety Systems

## Multi-Function Buttons

Button illumination is controlled by terminal 58d.









Only one code is used to communicate information from the buttons, through the steering column electronic systems control module, to the CAN-bus. This means that buttons can only function one at a time.

If a telephone is not installed, the telephone buttons are non-functional.

If after several minutes the system detects a sticking button it will disable the function. All other buttons will remain functional.



S319\_025

Button Symbol	Description
	Switch to basic telephone menu, various sub functions, such as caller list, make connection Accept call, make call
	Mute selection of audio sources
	End call
	Switch (mode) between FM/AM audio sources, CD-changer and CD (radio)
	Next track/start station search
	Previous track/start station search
	Volume up
	Volume down

# Convenience and Safety Systems

## Headliner Printed Circuits

An increase in headroom has been achieved by using printed circuits. Routing of wire is eliminated because the printed circuit wiring is attached to the headliner. Additional wire clips in the roof area are no longer required.

### Description

The printed circuit wiring connects the rear interior light, the sun visor switch and the vanity mirror lighting to the vehicle electrical system control module.

The central coupling point connection is located on the front cross member, above the front interior light.



Headliner printed circuits are not serviceable. The printed circuit must be replaced as a complete unit. Always refer to the latest service repair information.

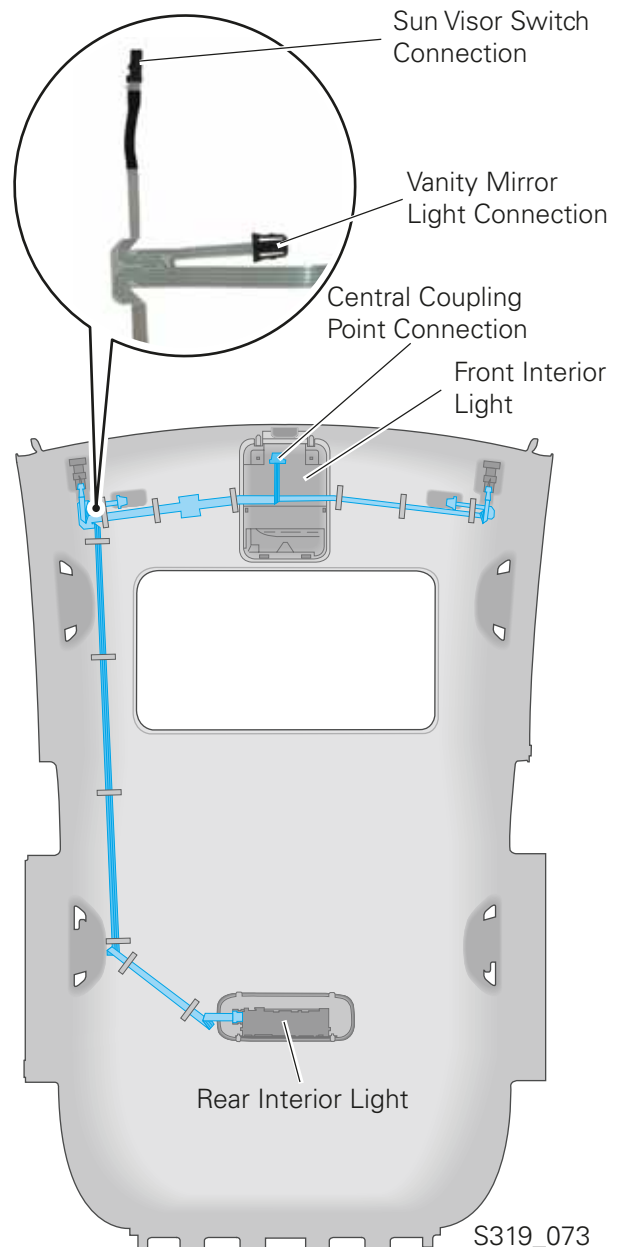

# Convenience and Safety Systems

---

## Tamper-Proof Guard

A tamper-proof fastener protects the new Jetta Motronic engine control module from tampering and unauthorized data access.

This tamper-proof fastener secures a protective cover over the main harness connector.



S319\_055





# Knowledge Assessment

---

An on-line Knowledge Assessment (exam) is available for this Self-Study Program.

The Knowledge Assessment may or may not be required for Certification.

You can find this Knowledge Assessment at:

**[www.vvwebservice.com](http://www.vvwebservice.com)**

From the vvwebservice.com Homepage:

- Click on the Certification tab
- Type the course number in the Search box
- Click "Go!" and wait until the screen refreshes
- Click "Start" to begin the Assessment

For Assistance, please call:

**Certification Program Headquarters**

**1 – 877 – CU4 – CERT**

**(1 – 877 – 284 – 2378)**

**(8:00 a.m. to 8:00 p.m. EST)**

Or, E-Mail:

**[Comments@VWCertification.com](mailto:Comments@VWCertification.com)**



Volkswagen of America, Inc.  
3800 Hamlin Road  
Auburn Hills, MI 48326  
Printed in U.S.A.  
December, 2004

