

Service Training



Self-Study Program 822703

Volkswagen 4.2L V8 FSI Engine



Volkswagen Group of America, Inc.
Volkswagen Academy
Printed in U.S.A.
Printed 5/2008
Course Number 822703

©2008 Volkswagen Group of America, Inc.

All rights reserved. All information contained in this manual is based on the latest information available at the time of printing and is subject to the copyright and other intellectual property rights of Volkswagen Group of America, Inc., its affiliated companies and its licensors. All rights are reserved to make changes at any time without notice. No part of this document may be reproduced, stored in a retrieval system, or transmitted in any form or by any means, electronic, mechanical, photocopying, recording or otherwise, nor may these materials be modified or reposted to other sites without the prior expressed written permission of the publisher.

All requests for permission to copy and redistribute information should be referred to Volkswagen Group of America, Inc.

Always check Technical Bulletins and the latest electronic repair information for information that may supersede any information included in this booklet.

Trademarks: All brand names and product names used in this manual are trade names, service marks, trademarks, or registered trademarks; and are the property of their respective owners.

Contents

Introduction	2
Engine Mechanical	4
Engine Management	20
Functional Diagram	32
Service	36
Knowledge Assessment.....	37

Note

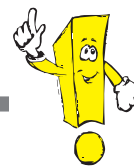

Important!



This Self-Study Program covers information on the Volkswagen 4.2L V8 FSI Engine. This Self-Study Program is not a Repair Manual. This information will not be updated.

For testing, adjustment and repair procedures, always refer to the latest electronic service information.

Introduction

Technical Features

The 4.2 Liter V8 4V FSI engine is the most recent example of the Fuel Straight Injection engines from Volkswagen. It is the successor to the 4.2 Liter V8 5V engine and is used in the Touareg.

The 2.0 Liter turbocharged FSI was the first engine introduced by VW with direct injection technology. Following its success, the 3.6 Liter V6 FSI and 4.2 Liter V8 4V FSI were introduced.

- Bosch Motronic MED 9.1.1
- Fuel Straight Injection (*FSI*)
- Electronic Throttle (*Electronic Pedal Control*)
- Two hot film mass airflow sensors
- Electronically regulated cooling system
- Adjustment of the variable intake manifold and intake manifold flap change-over by means of an electric motor
- Continuous inlet and exhaust camshaft timing adjustment
- Two-piece cylinder block
- Chain drives for camshafts and ancillary drives mounted on the flywheel side of the engine
- Spur gear drive for ancillary units
- Secondary air injection system

4.2L V8 FSI Engine

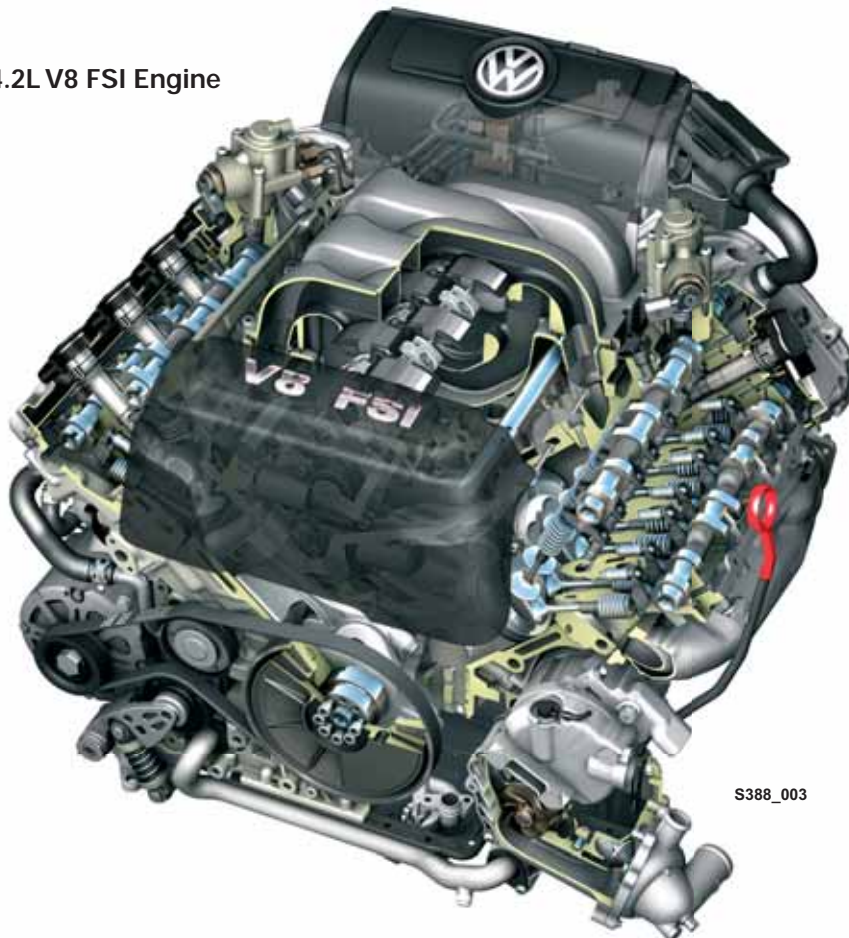

S388_003

Technical Data



Engine Code	BAR
Type	8 cylinders with 90° V angle
Displacement in	254 cubic in (4163 cc)
Bore in	3.32 in (84.5 mm)
Stroke in	3.65 in (92.8 mm)
Valves per Cylinder	4
Compression Ratio	12.5 : 1
Maximum Output	350 hp (257 kW) at 6800 rpm
Maximum Torque	325 lb ft (440 Nm) at 3500 rpm
Engine Management	Bosch Motronic MED 9.1.1
Fuel	Premium plus unleaded RON 98 or premium unleaded RON 95
Exhaust Gas Treatment	4 catalytic converters, 4 O2 sensors, secondary air system
Emissions Standard	LEV II

Engine Mechanical

Chain Drive

In the 4.2l V8 4V FSI engine, the camshafts and ancillary units are driven by a total of four roller chains on two levels. The chain drive is maintenance-free and reduces the over-all length of the engine.

The crankshaft drives the two drive gears for the camshaft timing chains via chain drive A. In turn, these two drive gears drive the camshaft adjusters for the exhaust and intake camshafts via chain drives B and C.

In chain drive D, the crankshaft drives the drive chain sprocket for ancillary drives. This is used to drive the spur gear for the ancillary units.

The chains are tensioned by hydraulic spring tensioners.

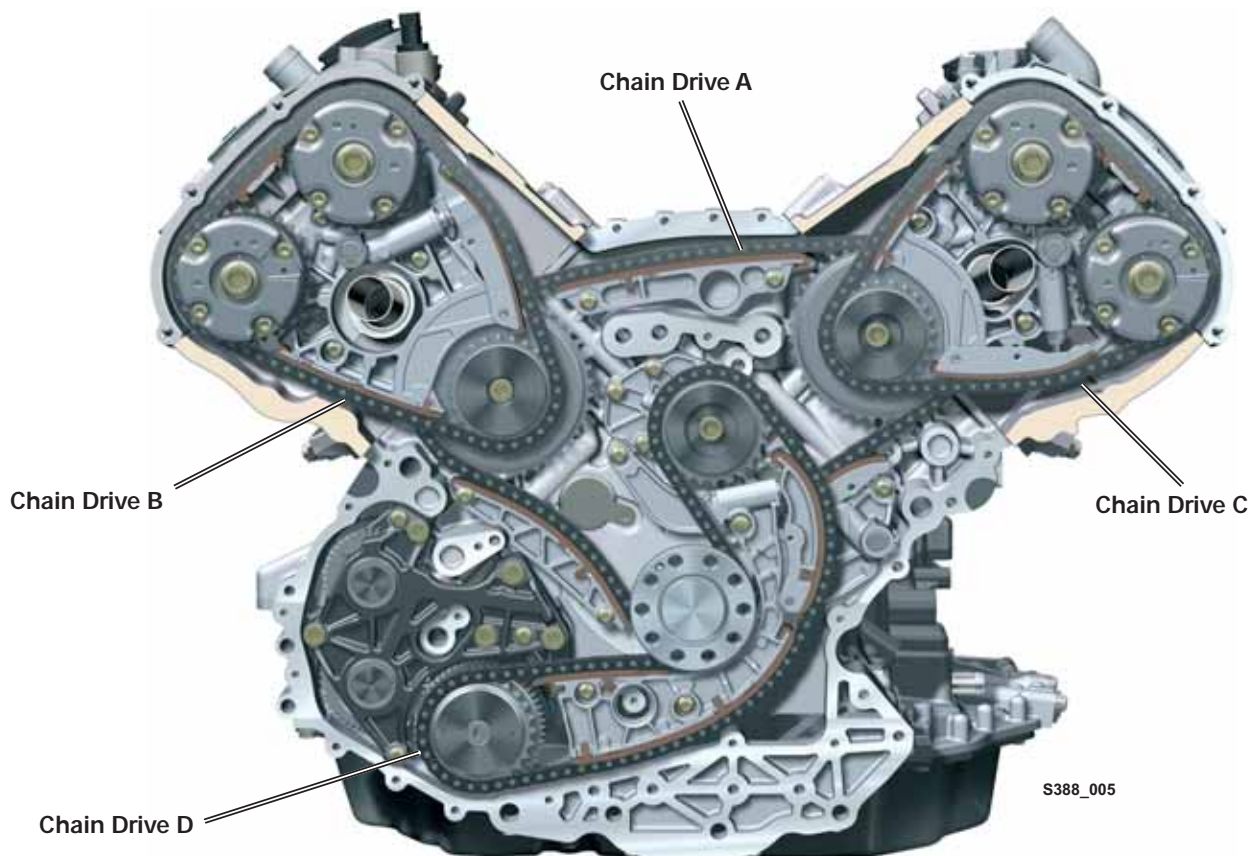

Engine Mechanical

Ancillary Unit Drive

The ancillary units (*engine coolant pump, power steering pump and A/C compressor*) are driven by the crankshaft via chain drive D, a spur gear drive, a gear module and four intermediate shafts.

The gear module is used to adapt the rotational speed and therefore the delivery rate of the engine coolant and oil pumps.

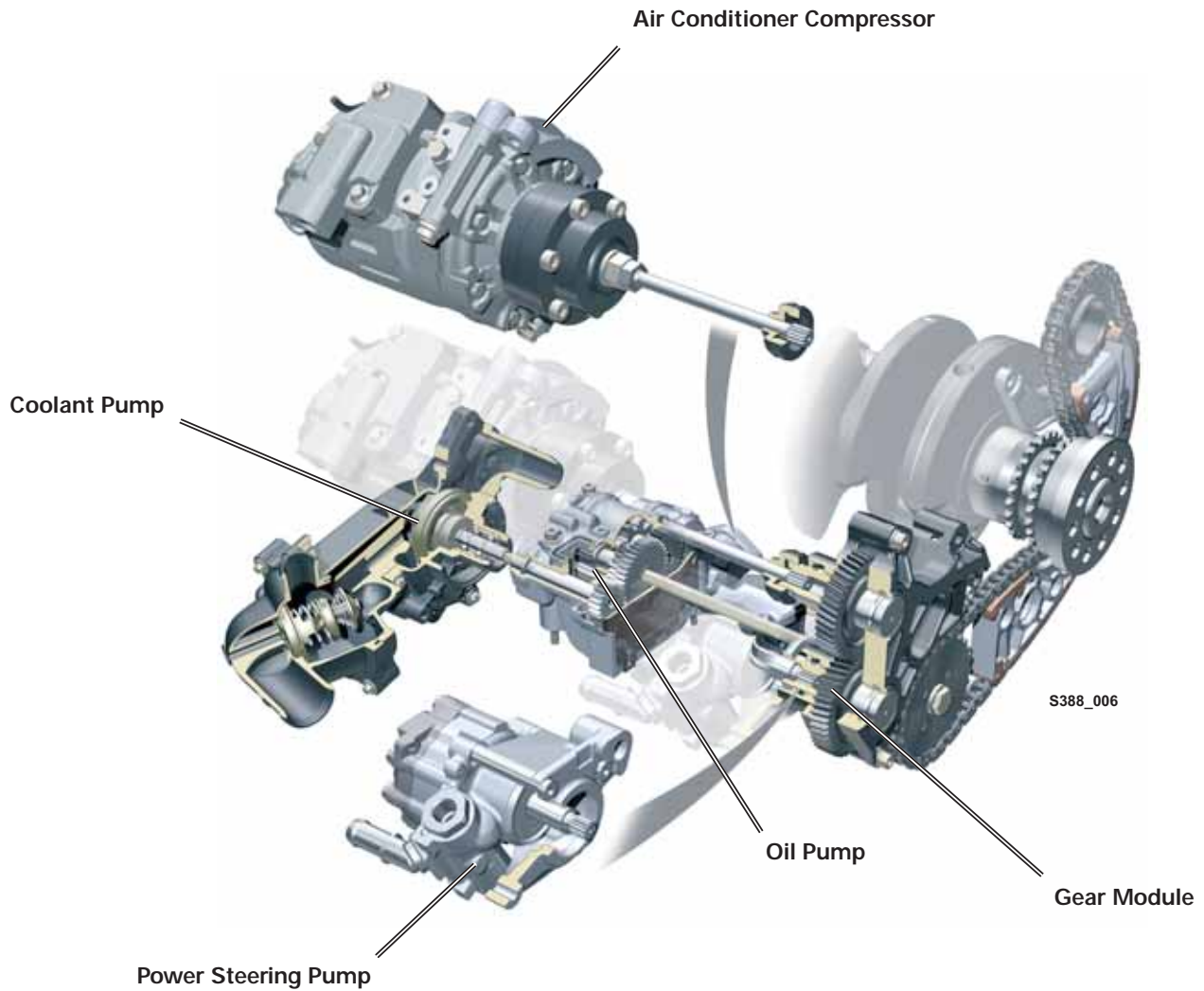

Engine Mechanical

Intake System

As in the 4.2 Liter V8 5V engine used previously in the Touareg, the fresh air intake system is designed with two branches, therefore reducing pressure losses.

Both intake tracts are brought together upstream of a common throttle valve module. Each intake track is equipped with a mass air flow sensor.

4.2L V8 FSI Intake System

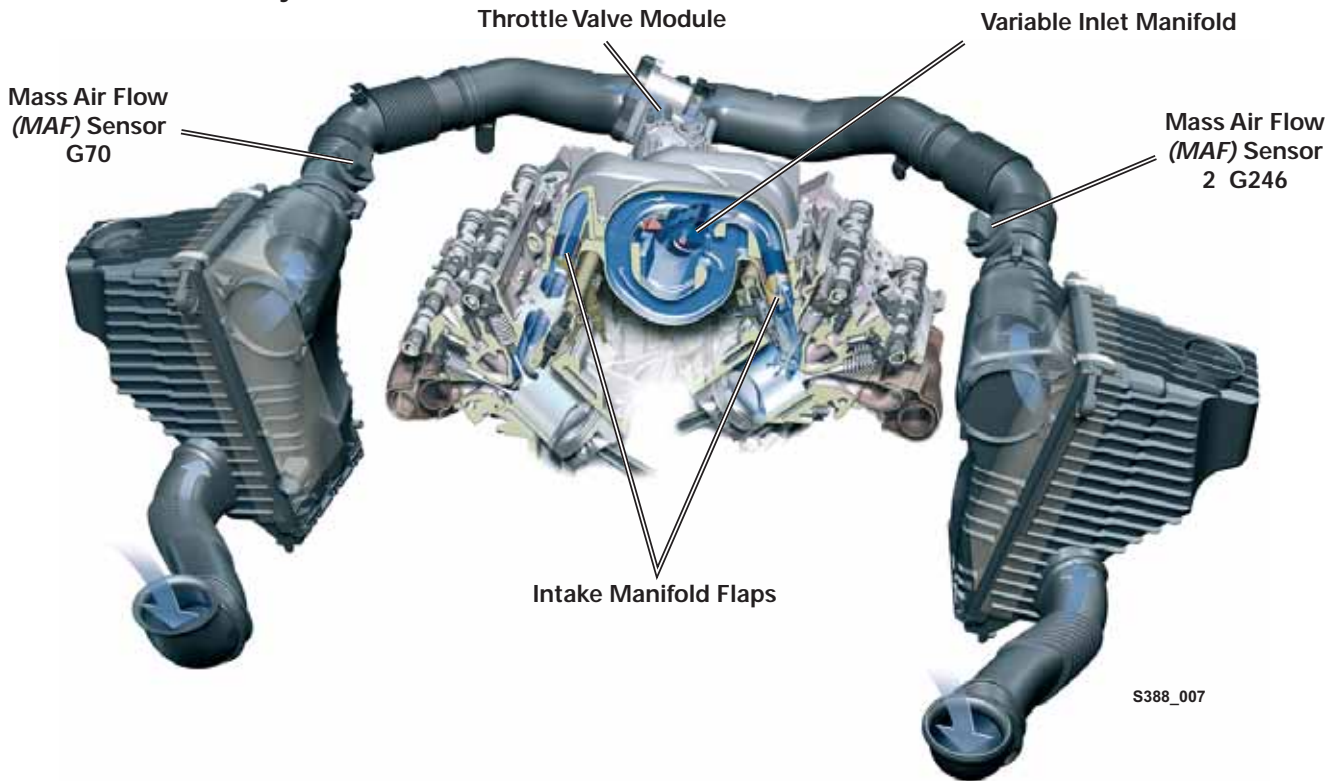

Intake Manifold

The two-stage variable intake manifold is manufactured from die-cast magnesium.

It houses the change-over flaps to vary the length of the intake runners as well as the flaps that change the airflow path near the intake valves.

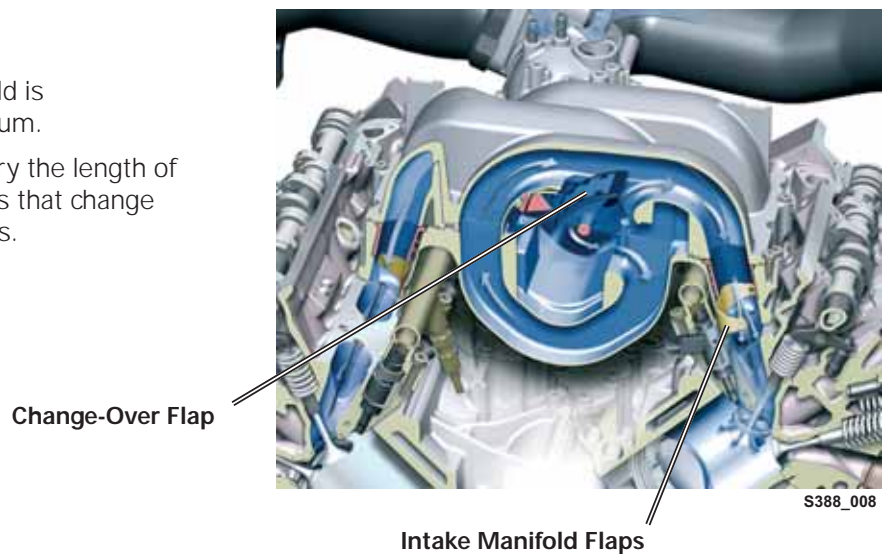

Variable Intake Manifold

Switching between the long and short intake manifold runners is determined by a performance map of the Engine Control Module.

- In the lower engine speed range, the long intake manifold runners are used (*torque position*)
- In the upper engine speed range, the short intake manifold runners are used (*output position*)

The change-over flaps are actuated by an electric motor on command from the Engine Control Module.

The change-over flaps have sealing lips to ensure that the long intake manifold remains leak-tight in the torque position.

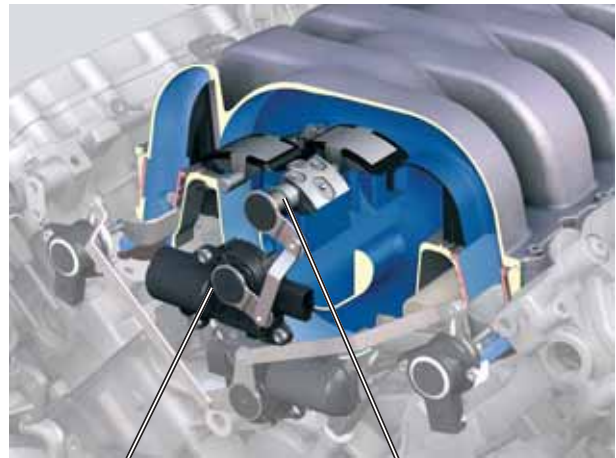

Variable Intake Manifold Runner Motor V183

Selector Shaft with Change-Over Flaps

Intake Manifold Flap Change-Over

The intake manifold flaps are installed in the two intake manifold lower sections. They are actuated, depending on load and engine speed, by an intake manifold flap motor and two linkage systems.

- At low load and engine speed, they are actuated and close off the lower section of the intake ports. This results in cylindrical-shaped air flow into the cylinder.
- At high load and engine speed, they are not actuated, and lie flush against the surface of the intake port in order to avoid flow losses.

Due to emission-relevant reasons, the positions of the intake manifold flaps are monitored by two intake manifold flap potentiometers.

Intake Manifold Runner Position Sensor G336

Intake Manifold Flaps

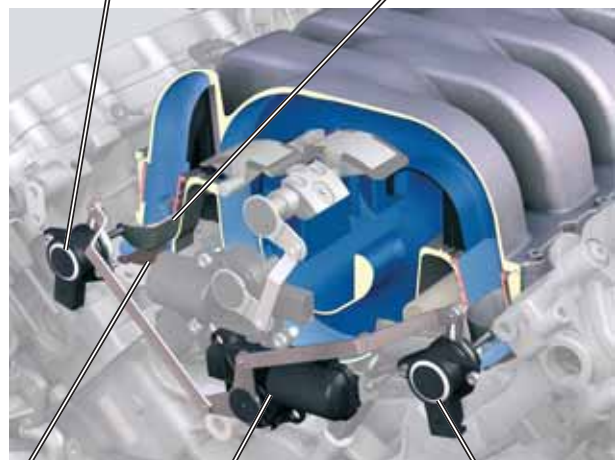

Separating Plate

Intake Flap Motor V157

Intake Manifold Runner Position Sensor 2 G512

Engine Mechanical

Cylinder Block

The cylinder block is manufactured from an aluminum-silicon alloy by means of low-pressure gravity die casting. It is characterized by high strength, very low cylinder warming and good thermal dissipation.

To obtain the narrowest cylinder webs possible, cylinder liners have been omitted.

Final cylinder bore surface machining is carried out in a three-stage honing and exposure process. During this process, the aluminum is separated from the surface and the silicon is exposed in the form of extremely small and particularly hard particles. These finally form the wear-resistant contact surface for the pistons and the piston rings.

The ladder frame is manufactured from an aluminum-silicon alloy by means of die casting. Cast-in bearing caps manufactured from cast iron with nodular graphite reinforce the ladder frame and absorb the majority of the flow of force. Due to their thermal expansion, which is lower than that of aluminum at high temperatures, they limit main bearing clearance.

The ladder frame design with bearing caps offers high longitudinal and transverse stiffness.

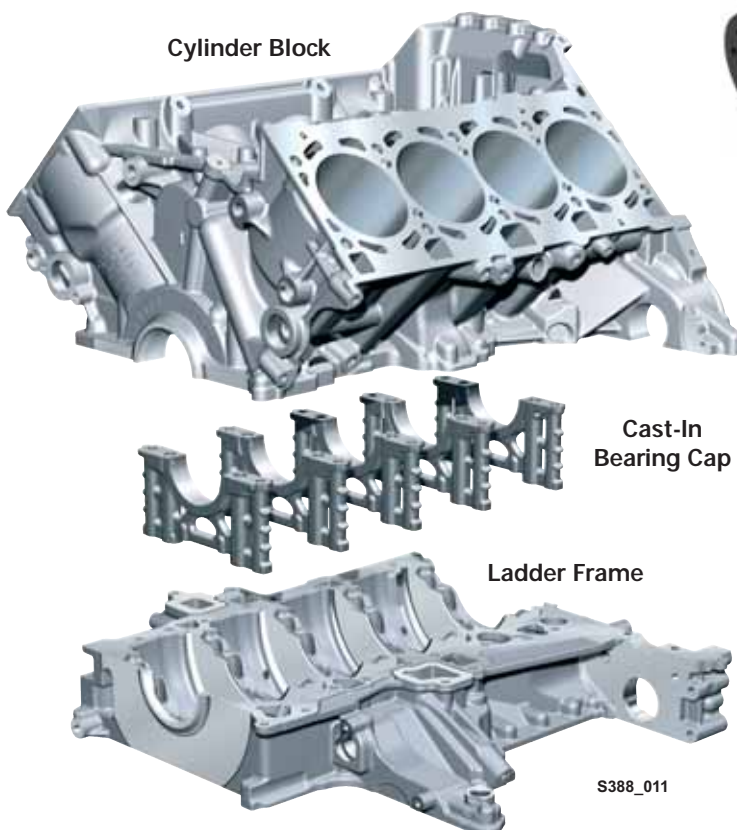

Crankshaft Drive

The crankshaft is manufactured from high-quality tempered steel, and is supported by five bearings.

The large ends of the connecting rods are cracked during manufacture. This ensures a tight, precise fit of the cap after the bearing has been installed.

Forged pistons are used for reasons of strength. The piston crowns have been adapted to the combustion process involved in FSI technology, and support the circular flow of air in the cylinder. The piston skirts are coated with Ferrostan, which contains iron. This prevents direct contact between the pistons and the cylinder walls, reducing wear.

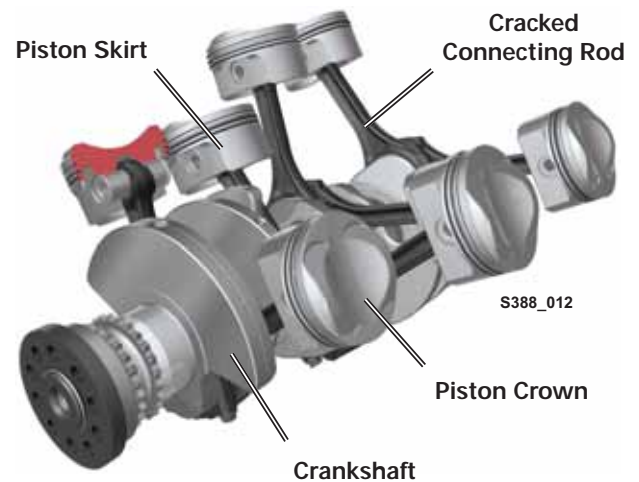

Engine Mechanical

Cylinder Heads

The 4-valve cylinder heads are manufactured from an aluminum alloy. This material provides very good thermal conductivity and high strength.

- The separating plates for intake manifold flap change-over are installed in the intake ports
- The injectors are fitted on the intake side in the cylinder head
- The high-pressure fuel pumps are driven by dual cams on the intake camshafts
- The cylinder head cover is made of plastic and contains a labyrinth oil separator
- The camshafts are fully-assembled (*the camshaft lobes are mated to the camshaft by a hydro-forming process*) and are driven by chain
- The exhaust valves are filled with sodium. This reduces the temperature at the valve by 212°F (100°C)

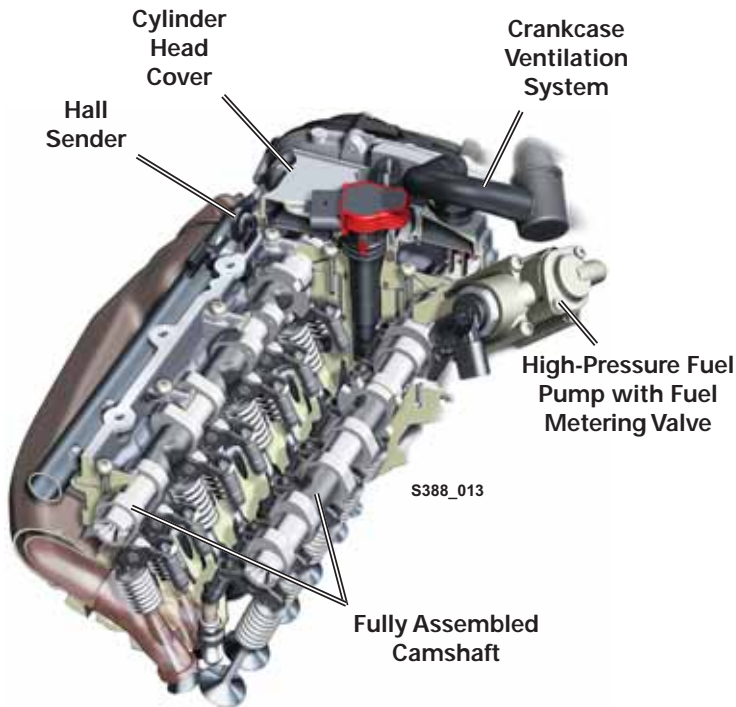

Camshaft Adjustment System

The gas exchange processes in the combustion chamber has a significant influence on output, torque and exhaust gas emissions. The camshaft adjustment system allows these gas exchange processes to be adapted to the engine's requirements.

Camshaft adjustment is carried out continuously by vane adjusters, and has a maximum of 42°. The position of the camshafts are detected by means of four Hall senders.

When the engine is not running, the vane adjusters are locked using a spring-loaded locking pin.

The intake camshafts are set to the "retarded" position and the exhaust camshafts to the "advanced" position. To achieve this, a return spring is installed in the exhaust camshaft vane adjusters.



Engine Mechanical

Oil Supply

During development of the oil supply system, emphasis was placed on achieving the lowest possible oil flow while providing sufficient lubrication.

As a result, the camshaft adjusters and various friction bearings were optimized. This engine's oil flow of 53 qt (50 l) per minute at 7000 rpm at a temperature of 248°F (120°C) is very low.

The advantage is that the oil remains in the oil sump for a longer period of time, and that better water and hydrocarbon (*uncombusted fuel*) degasification is possible. Additionally, a smaller oil pump can be used. This results in reducing the necessary drive power and therefore, lowering fuel consumption.

A baffle plate in the area of the intake connection ensures that no oil, which has been worked into a foam by the oil pump, is drawn into the oil system.

The oil is cooled by an oil-water heat exchanger.

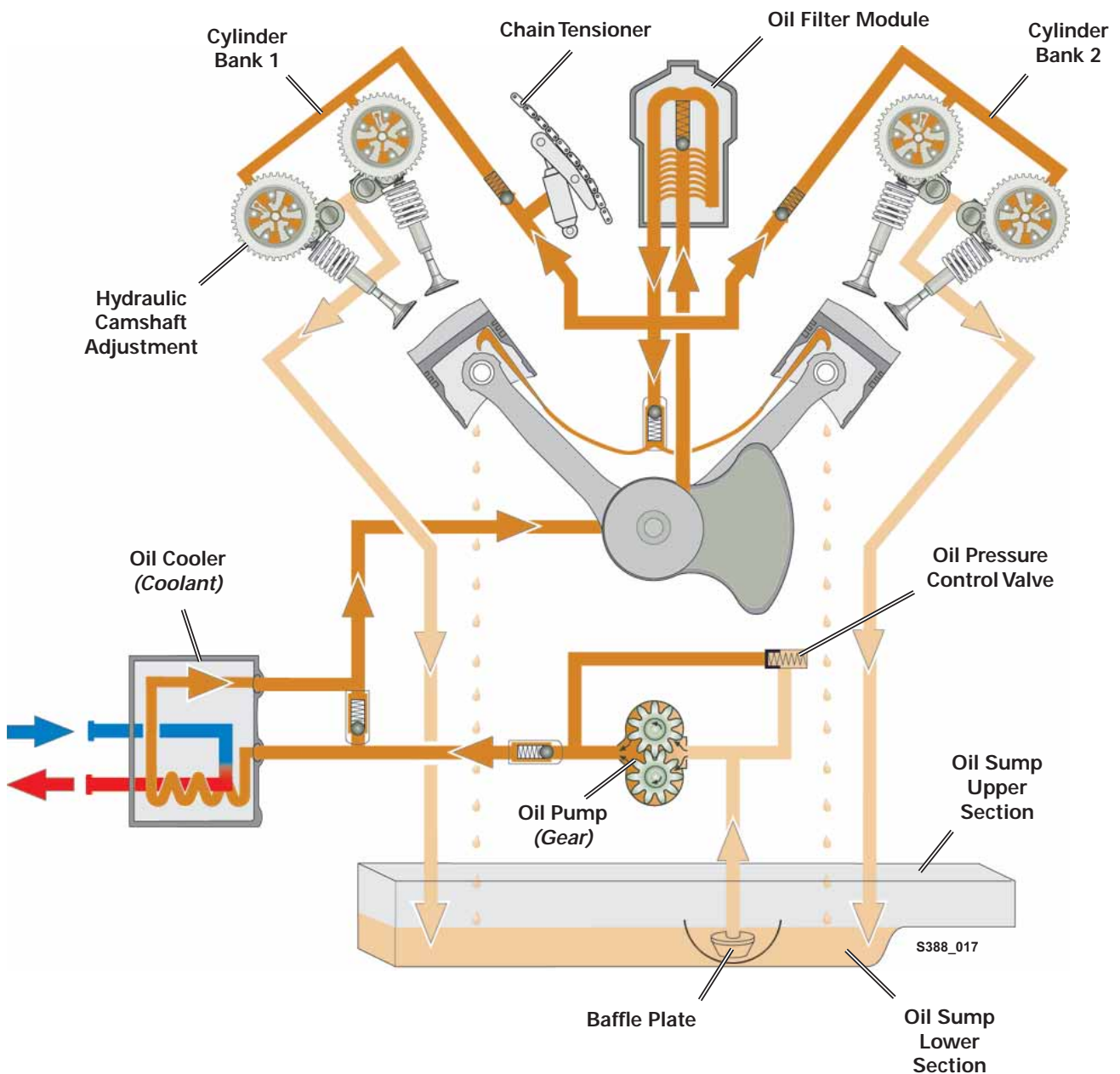

Engine Mechanical

Oil Pump

The oil pump is located inside the oil sump upper section and is bolted to the ladder frame. Oil intake is first through a base filter located on the suction side of the pump. All engine lubrication points are supplied from the pressure side of the oil circuit.

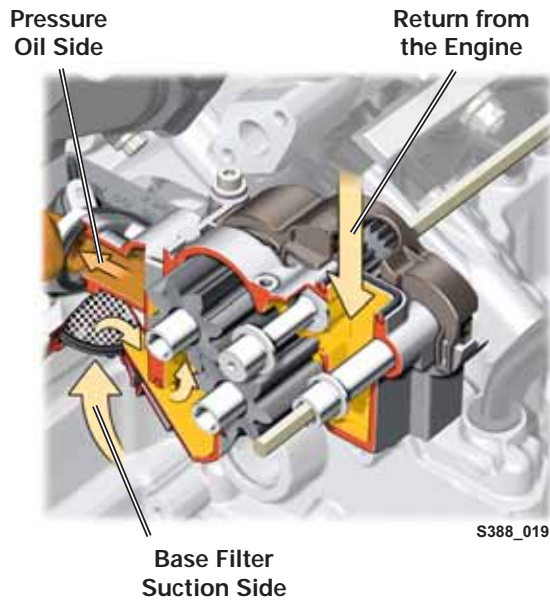

Oil Filter Module

The oil filter module is designed as a full-flow filter. It is located in the inner V of the engine and the filter element can be easily replaced without special tools.

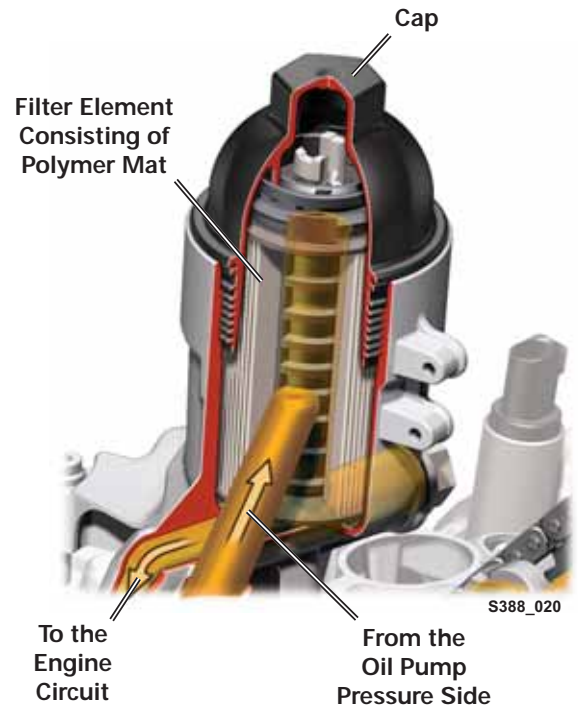

Engine Mechanical

Crankcase Breather and Ventilation System

Crankcase Breather System

The crankcase breather system is used to flush fresh air through the crankcase. As a result, water vapor and low-boiling hydrocarbons are removed from the crankcase and diverted back into the engine intake air to be burned.

The air is removed downstream of the air filter, and is guided into the inner V of the cylinder block by a non-return valve. A restrictor downstream of the non-return valve ensures that only the correct quantity of fresh air is supplied to the crankcase.

Crankcase Ventilation System

Because of the crankcase ventilation system, the uncombusted hydrocarbons (*blow-by gases*) are returned to the combustion process and do not escape into the outside air.

To minimize the oil contained in the blow-by gases, they are separated by a labyrinth oil separator in the cylinder head cover and a three-stage cyclonic micro oil separator.

In the cylinder head cover, the gas encounters impact plates, where the larger oil droplets are separated. The gases are then channeled by hoses to the micro oil separator. Here, the smaller oil droplets are separated off, preventing intake valve coking. The induction point downstream of the throttle valve module is integrated into the engine cooling circuit to prevent it from freezing.

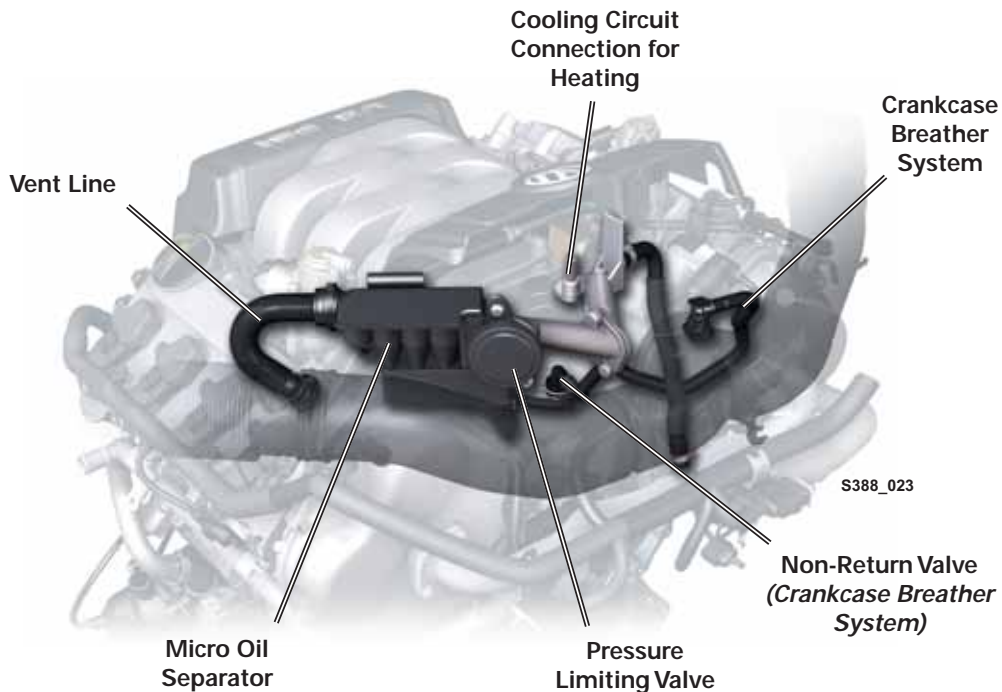

Engine Mechanical

Three-Stage Cyclonic Micro Oil Separator

The quantity of uncombusted hydrocarbons and oil vapor is dependent on the engine load and speed. The oil mixed with unburned hydrocarbons is separated by a three-stage cyclonic micro oil separator.

Because cyclonic oil separators only perform well in a low volumetric flow range, one, two or three cyclones are released in parallel depending on the quantity of gas.

Low Engine Load/Speed — Low Gas Flow

At low engine load and speed, the gas flow is low. The gas flows past the control plunger into the first cyclonic oil separator. Here, the oil still present in the gas is pressed outwards by centrifugal force, adheres to the wall and drips into the oil collection chamber.

The oil collection chamber contains an oil drain valve, which is closed by the pressure in the crankcase when the engine is running. When the engine is switched off, the valve opens and the collected oil flows into the oil sump through a hose located below the level of the oil. The pressure control valve ensures a constant pressure level and good crankcase ventilation.

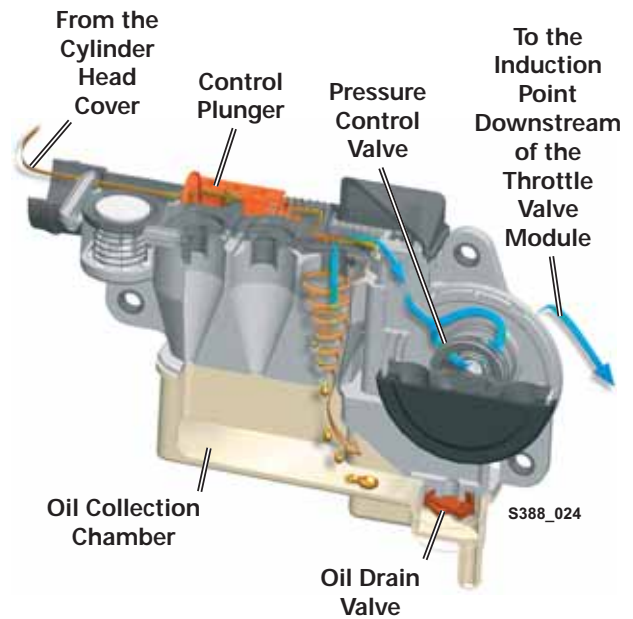

Increasing Engine Load/Speed — Increasing Gas Flow

As the engine load and speed increases, so to does the flow of the blow-by gases. The higher the flow, the greater the force which acts on the control plunger. The control plunger force overcomes the spring force and releases the access ducts to further cyclones.

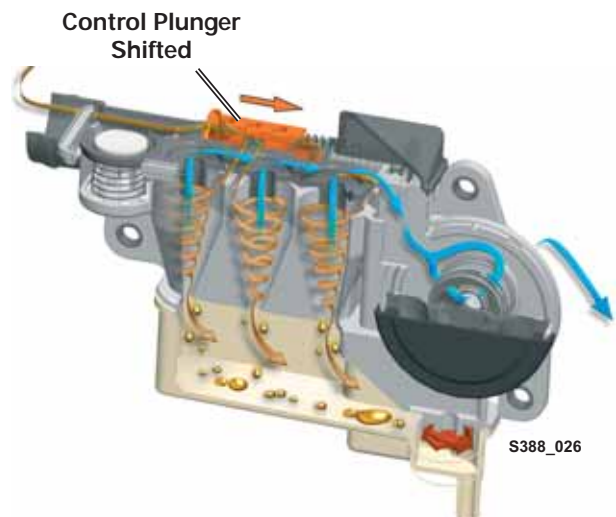

Engine Mechanical

Bypass Valve Opens — Very High Gas Flow

The bypass valve ensures that the pressure in the crankcase does not become excessive.

If the pressure in the crankcase increases rapidly, for example due to a jammed control plunger or piston ring flutter (*may occur at high engine speeds and low load*), the cyclones are no longer able to cope with this pressure increase. The pressure continues to rise and now opens the bypass valve. Part of the blow-by gases now flow past the cyclone and are guided to the intake manifold directly through the pressure control valve.

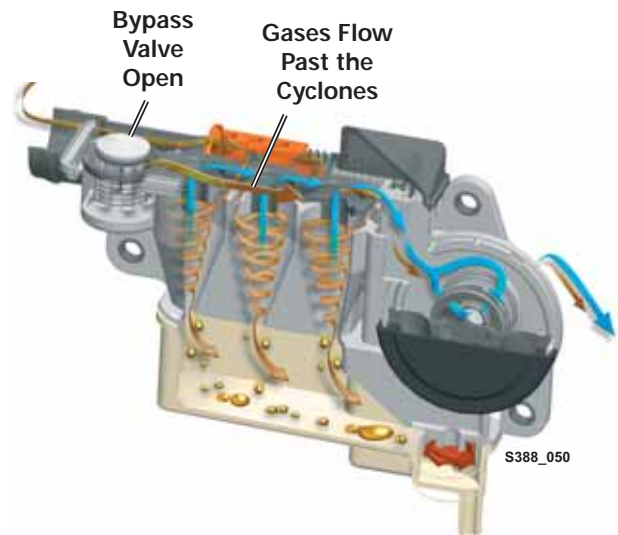

Engine Cooling Circuit

The cooling system is designed as a longitudinal cooling system. The coolant flows in on the intake side, through the cylinder head gasket and into the head, where it flows out through the timing chain cover. Cylinder web cooling has been improved by drilling coolant ducts with cross-sections into the webs. Forced flow through these bores is ensured with the aid of specifically sealed water ducts.

In addition, the engine is equipped with an electronically controlled cooling system.

- In the partial load range which is not critical with regards to engine knock, the coolant temperature is regulated to 221°F (105°C). In the lower partial load range, the thermodynamic advantages and reduced friction result in a fuel saving of approximately 1.5%.
- In the full load range, the coolant temperature is regulated to 194°F (90°C) by the map-controlled engine cooling system thermostat. This creates cooler combustion chambers and better cylinder charging with reduced knock tendency.

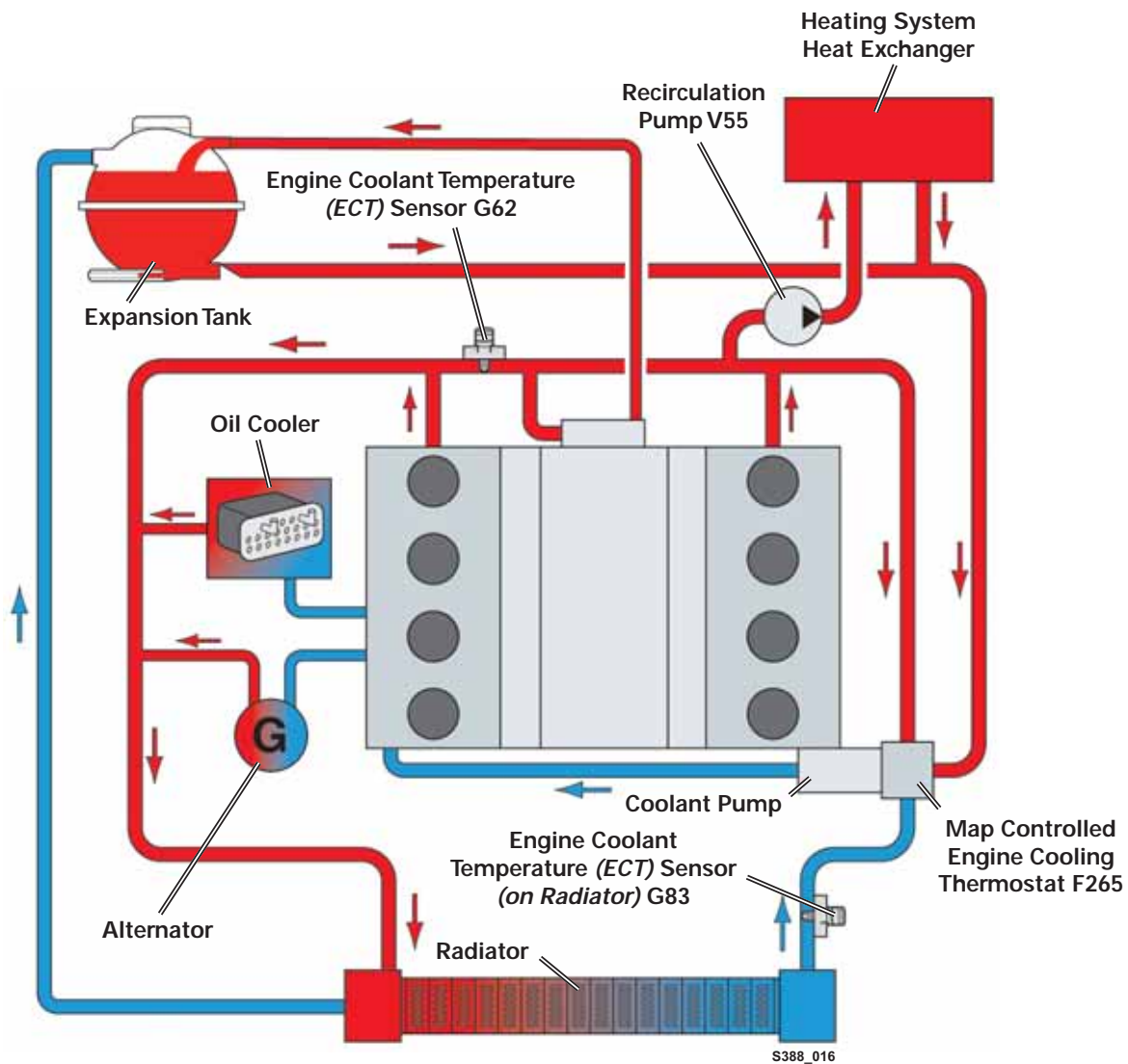

Engine Mechanical

Fuel System

The fuel system is a requirement-controlled fuel system. This means that both the electric transfer fuel pump and the two high-pressure fuel pumps only deliver the amount of fuel required by the engine at that particular moment. As a result, the electrical and mechanical power requirements are reduced and fuel consumption is lowered.

The fuel system is sub-divided into a low-pressure and a high-pressure fuel system.

- The fuel pressure of up to 102 psi (7 bar) in the low-pressure fuel system is generated by an electric transfer fuel pump, which is actuated by the engine control module through Fuel Pump Control Module J538.
- The fuel pressure of 363 psi (25 bar) to 1523 psi (105 bar) in the high-pressure fuel system is generated by two mechanical high-pressure fuel pumps, each of which is driven via a dual cam by the intake camshafts.

To minimize fuel pressure pulsations, both high-pressure fuel pumps deliver fuel into a common fuel line to the fuel rails. In addition, the high pressure delivery has been designed so that pressure impulses of the pumps are offset at the common rail.

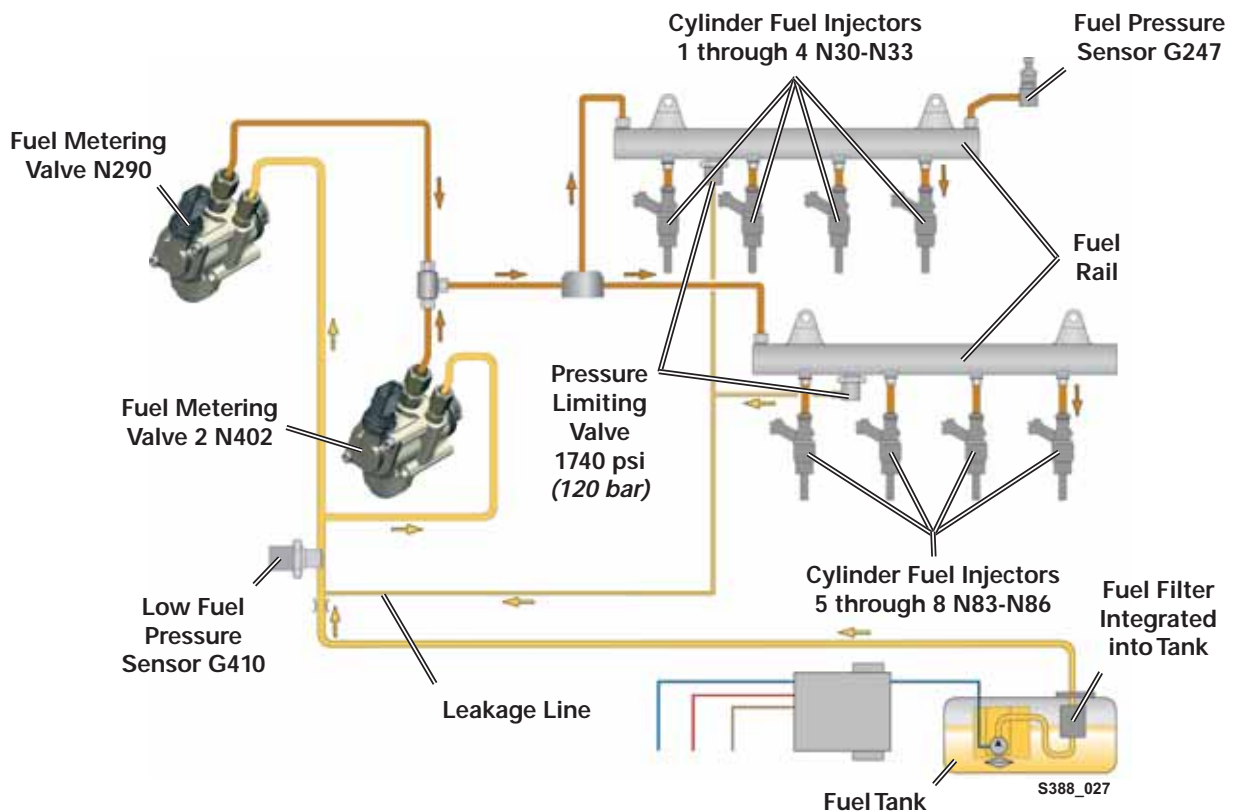

Exhaust System

The exhaust system is a twin-branch design. This means that each cylinder head has a separate exhaust tract.

The exhaust manifolds are insulated sheet metal manifolds with a gas-tight inner shell. This air-gap insulation enables a compact design and fast heating. Additional heat shields are no longer necessary. The exhaust manifolds are secured to the cylinder heads using clamping flanges.

Two broadband oxygen sensors are installed downstream of the exhaust manifolds and two oxygen sensors downstream of the pre-catalytic converters.

The starter and main catalytic converter substrate material is comprised of ceramic.

Both exhaust tracts end in the front silencer. There, the sound waves overlap and noise emissions decrease. Two exhaust pipes lead from the front silencer to the rear silencer. Both exhaust pipes are routed separately in the interior of the rear silencer.

The exhaust gas flows into the outside air via two tailpipes.

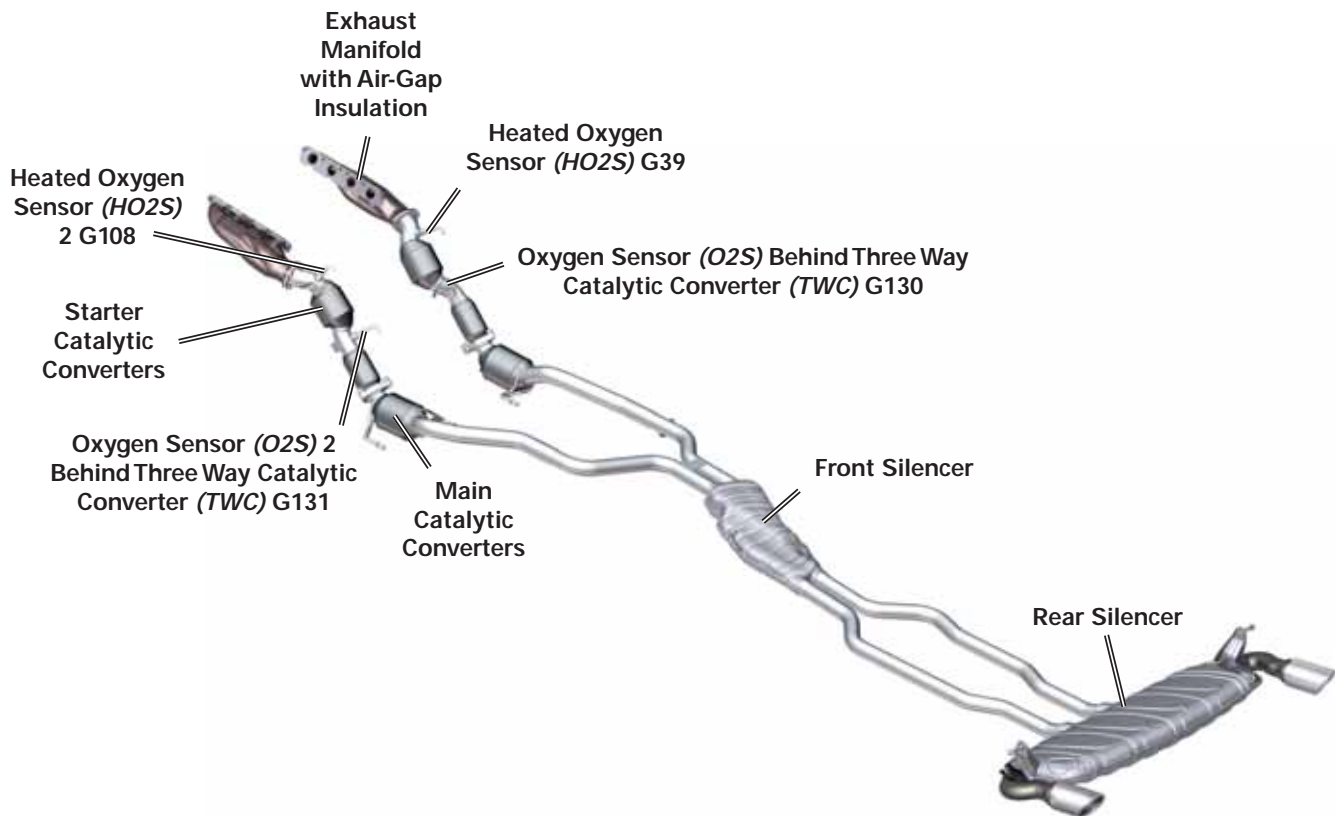

Engine Mechanical

Secondary Air Injection System

To heat the catalytic converters as quickly as possible, the fuel mixture is enriched during cold-starting and warm-up. This results in a higher percentage of uncombusted hydrocarbons in the exhaust gas during this period.

Because of the air injection downstream of the exhaust valves, the exhaust gases are enriched with oxygen, leading to oxidation (*afterburning*) of the hydrocarbons and the carbon monoxide. The heat released during this process also heats the catalytic converter, helping it to reach its operating temperature faster.

The secondary air injection system is comprised of:

- Secondary Air Injection (AIR) Pump Relay J299
- Secondary Air Injection (AIR) Pump Motor V101
- Two self-opening combination valves

Input signals:

- Signal from the Oxygen Sensors (*for system diagnosis*)
- Engine Coolant Temperature Sensors
- Mass Airflow Sensor load signals

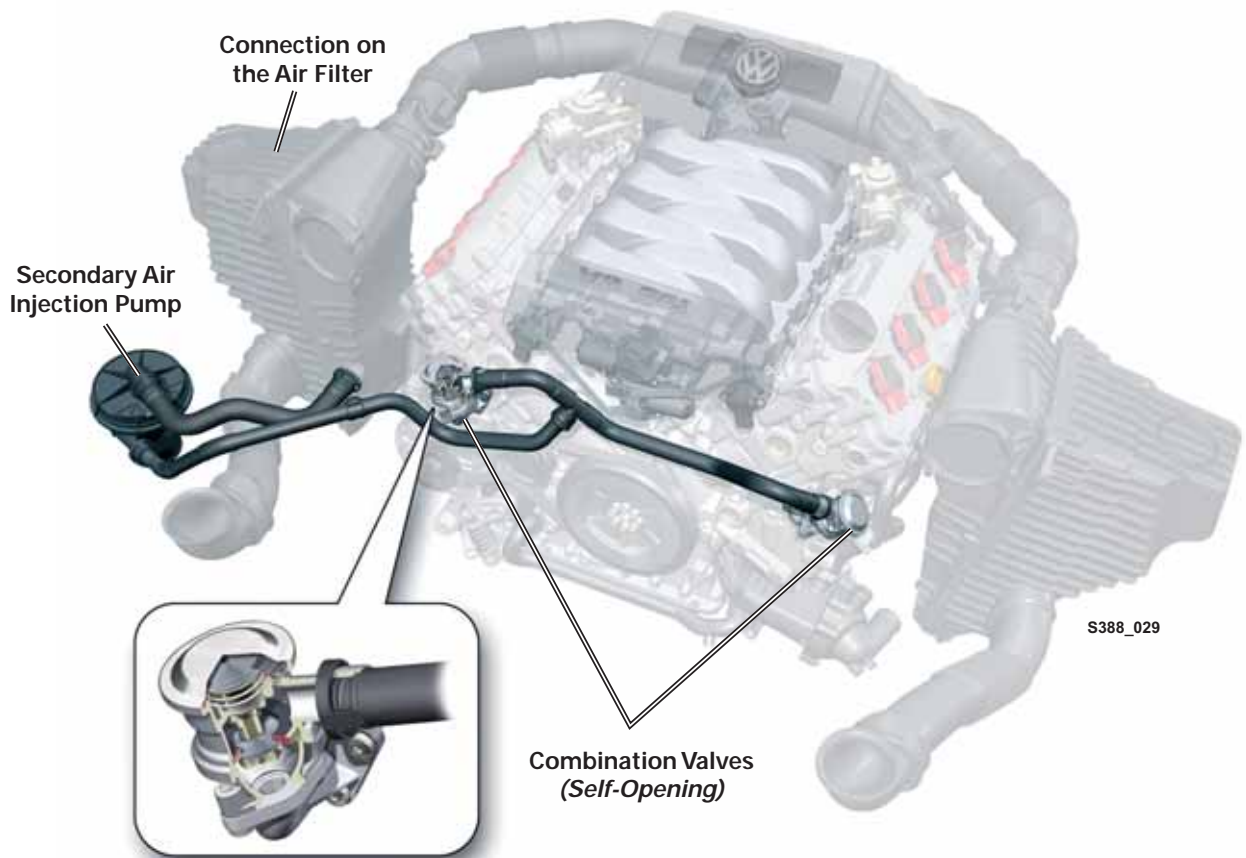

Engine Mechanical

Secondary Air Injection

The secondary air injection system is activated during cold-starting, at the start of the warm-up phase and for test purposes as part of OBD II requirements. In this case, the engine control module actuates the secondary air pump through the secondary air pump relay. When the pressure is present at the combination valves, they open and the air flows downstream of the exhaust valves. Afterburning takes place.

Function of the Combination Valves

The combination valves are self-opening valves. This means that they are opened through the pressure generated by the secondary air pump, and not by vacuum as in the previous secondary air systems.

Combination Valve Closed

The pressure in the combination valves corresponds to ambient pressure. The valves are closed.

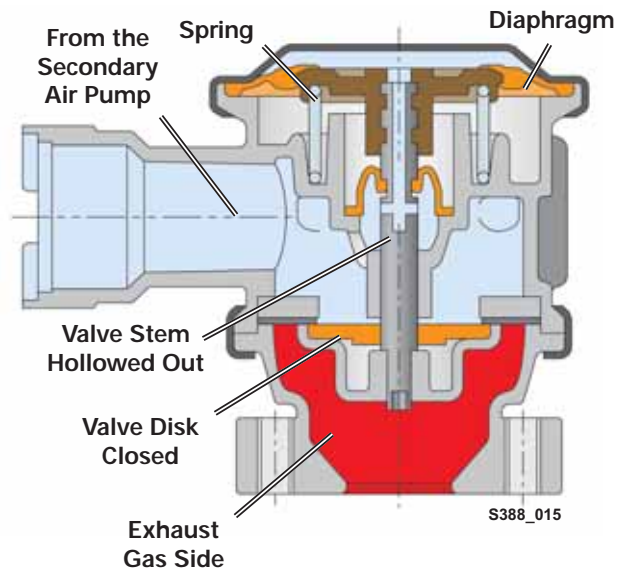

Combination Valve Open

If the current for the secondary air pump is activated by the relay, it begins to deliver air. Pressure builds up due to the fact that the combination valve is closed. This is present at the valve disk and, through the hollowed-out valve stem, at the diaphragm. If a pressure of approximately 6.5 psi (450 mbar) above ambient pressure acts on the diaphragm and the valve disk, the valve opens.

The air delivered by the secondary air pump now flows downstream of the exhaust valves and afterburning takes place.

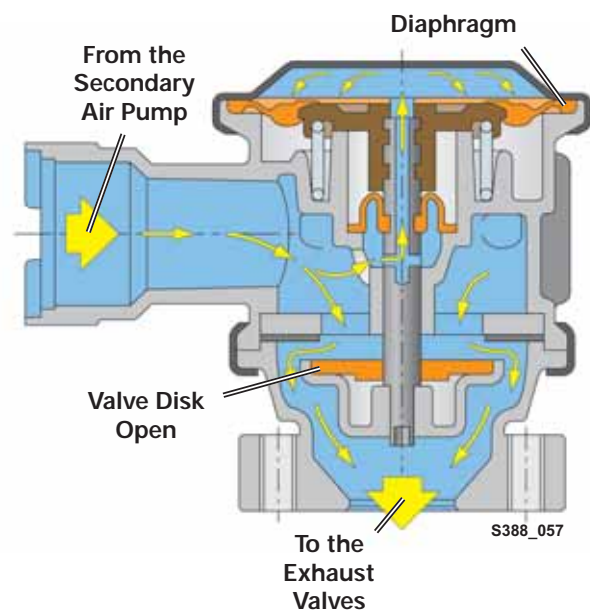

Engine Management

System Overview

Sensors

Mass Air Flow (MAF) Sensors, G70, G246
Intake Air Temperature (IAT) Sensor G42

Engine Speed (RPM) Sensor G28

Throttle Position (TP) Sensors G79, G185

Camshaft Position (CMP) Sensors G40, G163, G300, G301

Throttle Valve Control Module J338
Throttle Drive Angle Sensors [for Electronic Power Control (EPC)] G187, G188

Intake Manifold Runner Position Sensors G336, G512

Low Fuel Pressure Sensor G410

Fuel Pressure Sensor G247

Engine Coolant Temperature (ECT) Sensor G62

Engine Coolant Temperature (ECT) Sensor (on Radiator) G83

Knock Sensors G61, G66, G198, G199

Oxygen Sensors G39, G108

Oxygen Sensors G130, G131

Brake Light Switch F
Brake Pedal Switch F47

Brake Booster Pressure Sensor G294

Additional Input Signals

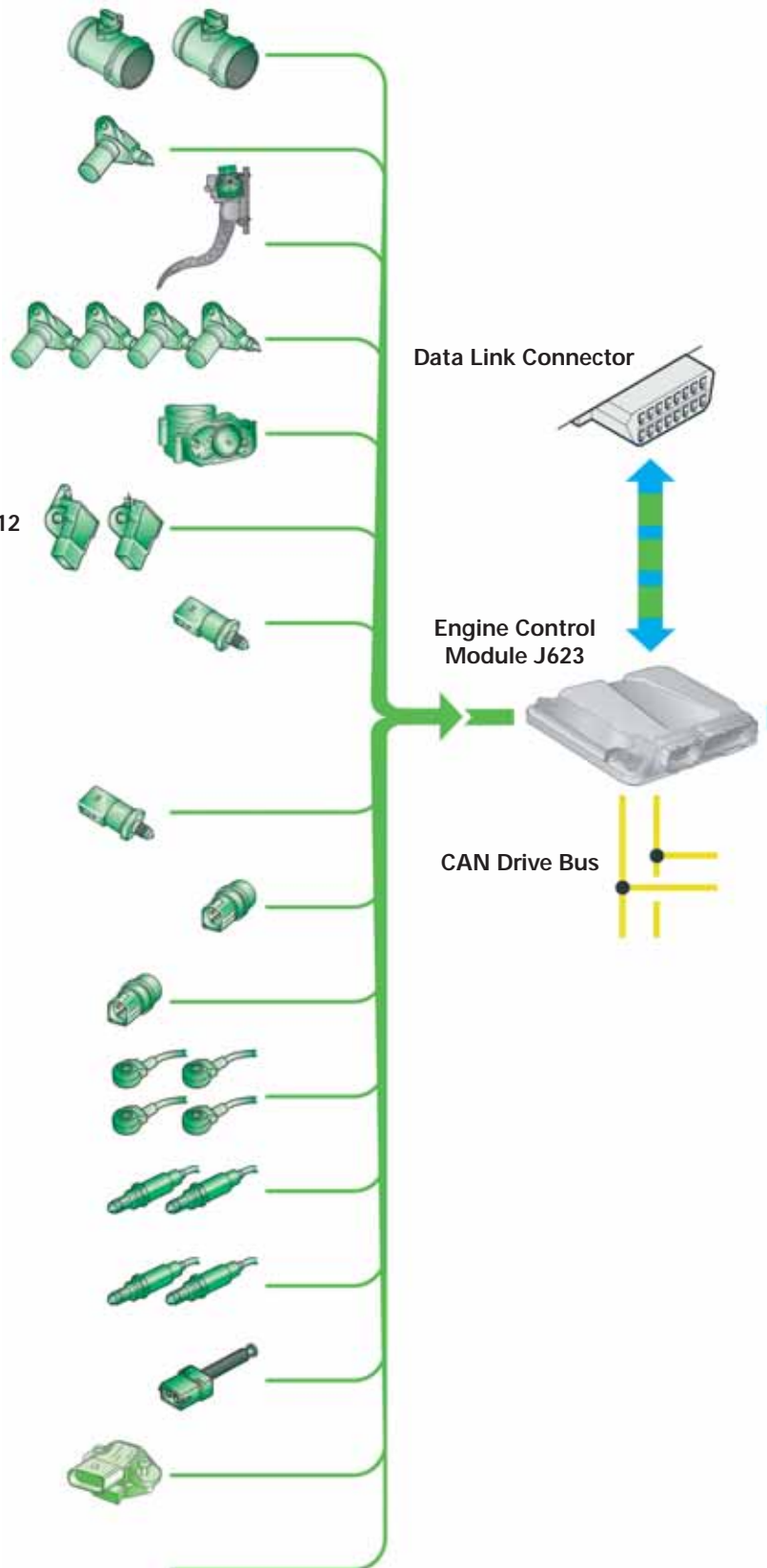

Engine Management

Actuators

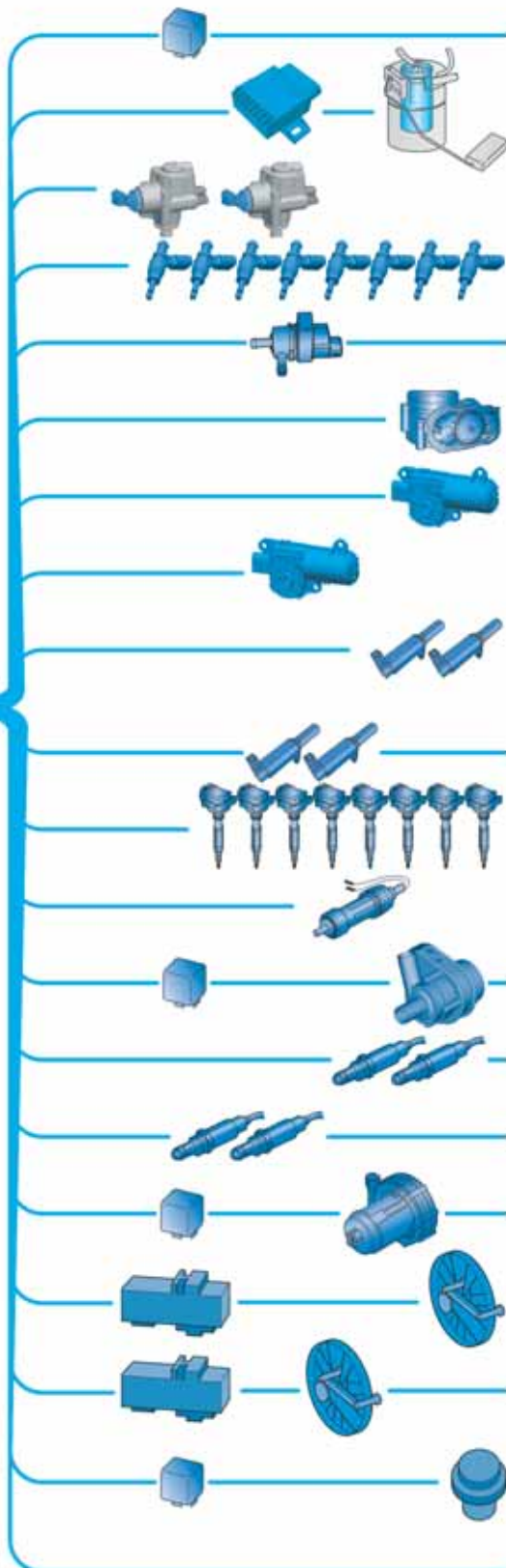

Motronic Engine Control Module (*ECM*)
Power Supply Relay J271

Fuel Pump (*FP*) Control Module J538
Transfer Fuel Pump (*FP*) G6

Fuel Metering Valves N290, N402

Cylinder Fuel Injectors 1 through 8 N30-33, N83-N86

Evaporative Emission Canister
Purge Regulator Valve N80

Throttle Valve Control Module J338
Throttle Drive [*for Electronic Power Control (EPC)*] G186

Intake Flap Motor V157

Variable Intake Manifold Runner Motor V183

Camshaft Adjustment Valves (*intake*) N205, N208

Camshaft Adjustment Valves (*exhaust*) N318, N319

Ignition Coils with Power Output Stages
N70, N127, N291, N292, N323-N326

Map Controlled Engine Cooling Thermostat N265

Coolant Circulation Pump Relay J151
Recirculation Pump V55

Oxygen Sensor (*O2S*) Heaters Z19, Z28

Oxygen Sensor (*O2S*) Heaters [*behind Three Way Catalytic Converter (TWC)*] Z29, Z30

Secondary Air Injection (*AIR*) Pump Relay J299
Secondary Air Injection (*AIR*) Pump Motor V01

Coolant Fan Control (*FC*) Control Module J293
Coolant Fan V7

Coolant Fan Control (*FC*) Control Module 2 J671
Coolant Fan 2 V177

Brake Booster Relay J569
Brake System Vacuum Pump V192

Additional Output Signals

S388_030

Engine Management

Sensors

Mass Air Flow Sensor with Intake Air Temperature Sensor G42 and Mass Air Flow Sensor 2 G246

To minimize pressure losses, the intake tract has a twin-branch design. The most accurate possible air mass signal is achieved using two Mass Air Flow Sensors. Mass Air Flow Sensor G70 is installed along with Intake Air Temperature Sensor G42 in the intake tract on the cylinder bank 1 side. Mass Airflow Sensor G246 is installed in the intake tract on the cylinder bank 2 side.

The engine control module calculates the mass and the temperature of the air from the signals transmitted by the two Mass Air Flow Sensors and the Intake Air Temperature Sensor.

**Mass Air Flow Sensor
with Intake Air
Temperature Sensor
G42 (Cylinder Bank 1)**

**Mass Air Flow
Sensor 2 G246
(Cylinder Bank 2)**



S388_032

Signal Use

The signals are used to calculate all load- and engine speed-dependent functions. These include the injection period, ignition timing or camshaft adjustment.

Effects in the Event of Failure

If one or both Mass Air Flow Sensors fail, the throttle valve position and the engine speed are used as correction values.

If the intake air temperature sender fails, a fixed, substitute value is used by the Engine Control Module.

Engine Management

Camshaft Position Sensors G40, G163, G300, G301

Camshaft Position Sensors G40 and G300 are located on cylinder bank 1 and Camshaft Position Sensors G163 and G301 are located on cylinder bank 2.

By scanning a quick-start sender wheel, the engine control module recognizes the position of each cylinder bank's intake and exhaust camshafts

Cylinder Bank 1

Camshaft Position Sensor G40 — intake camshaft

Camshaft Position Sensor G300 — exhaust camshaft

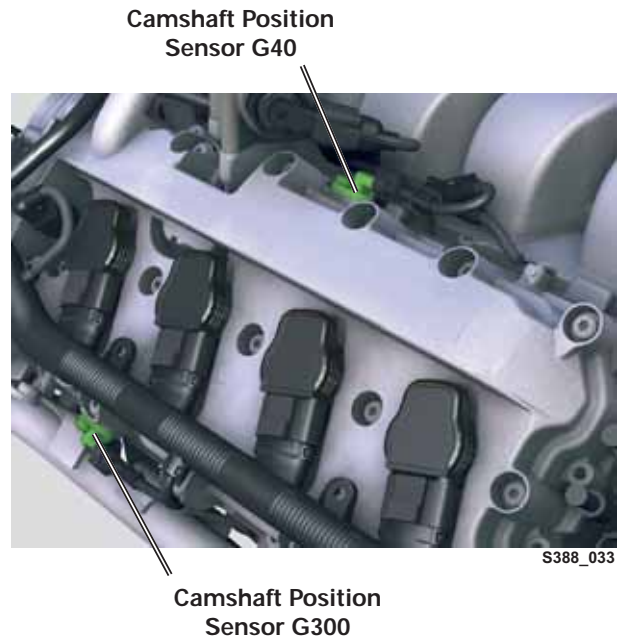

Cylinder Bank 2

Camshaft Position Sensor G163 — intake camshaft

Camshaft Position Sensor G301 — exhaust camshaft

Signal Use

The signals are used to detect the first cylinder at the firing position, for camshaft adjustment, and to calculate the injection point and the ignition timing.

Effects in the Event of Signal Failure

No further camshaft adjustment takes place if a Camshaft Position Sensor fails. The engine continues to run and also re-starts again after switching off because of run-on recognition, however, torque and power are reduced.



Engine Management

Low Fuel Pressure Sensor G410

This sensor is installed in the supply line to the two high-pressure fuel pumps. It measures the fuel pressure in the low-pressure fuel system and transmits a signal to the engine control module.

Low Fuel Pressure
Sensor G410



S388_035

Signal Use

The signal is used by the engine control module to regulate the low-pressure fuel system. Following the sensor signal, the engine control module transmits a signal to Fuel Pump (FP) Control Module J538, which then regulates Transfer Fuel Pump G6 as required.

Effects in the Event of Signal Failure

If the fuel pressure sensor fails, the fuel pressure is regulated by a fuel pressure pilot control system. The fuel pressure is then approximately 94.2 psi (6.4 bar).

Engine Management

Fuel Pressure Sensor G247

The sensor is located in the inner V of the cylinder block, and is connected to the fuel rail by a separate fuel line. It measures the fuel pressure in the high-pressure fuel system and transmits the signal to the engine control module.

Signal Use

The engine control module evaluates the signals and regulates the pressure in the fuel rail pipes via the two fuel metering valves.

Effects in the Event of Signal Failure

If Fuel Pressure Sensor G247 fails, no further high fuel pressure is built up. The engine runs in emergency mode with low fuel pressure. Power and torque are reduced.

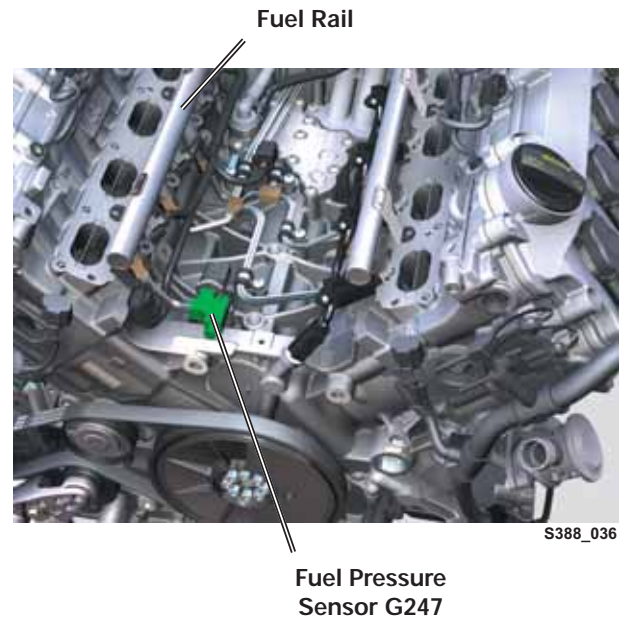

Engine Management

Intake Manifold Runner Position Sensors G336 and G512

The two intake manifold flap potentiometers are secured to the intake manifold and are connected to the shaft for the intake manifold flaps. They recognize the position of the intake manifold flaps.

Intake Manifold Runner
Position Sensor 2 G512



Intake Manifold Runner
Position Sensor G336

Signal Use

The position is important, as intake manifold change-over affects air flow in the combustion chamber and the inlet air mass. The position of the intake manifold flaps is therefore relevant to the exhaust gas, and must be checked via self-diagnosis.

Effects in the Event of Signal Failure

If the signal from the position sensor fails, the position of the intake manifold flaps at the time of failure and the relevant ignition timing are used as substitute values. Power and torque are reduced and fuel consumption increases.

Engine Management

Actuators

Transfer Fuel Pump G6

The electric fuel pump and the fuel filter are combined to form a fuel delivery unit. The fuel delivery unit is located in the fuel tank.

Task

Transfer Fuel Pump G6 delivers the fuel in the low-pressure fuel system to the high-pressure fuel pump. It is actuated with a PWM signal by Fuel Pump Control Module J538.

Transfer Fuel Pump G6 always supplies the quantity of fuel required by the engine at the present moment in time.

Effects in the Event of Failure

If Transfer Fuel Pump G6 fails, engine operation is no longer possible.

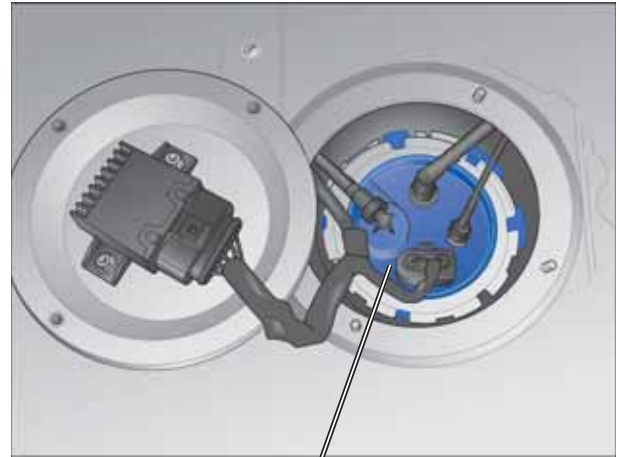

Fuel Pump G6

Fuel Pump Control Module J538

Fuel Pump Control Module J538 is mounted under the rear seat on the cover for the electronic fuel pump.

Task

The Fuel Pump Control Module receives a signal from the Engine Control Module and controls the electronic fuel pump with a PWM signal (*pulse-width modulated*). It regulates the pressure in the low-pressure fuel system between 72.5 psi (5 bar) and 101.5 psi (7 bar).

Effects in the Event of Failure

If Fuel Pump Control Module J538 fails, engine operation is not possible.

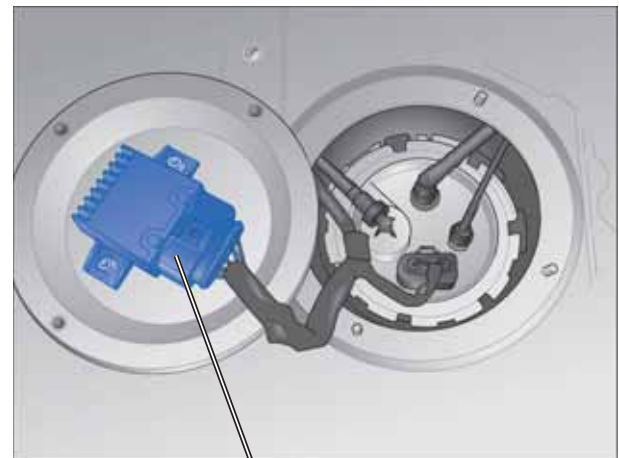

Fuel Pump Control
Module J538

Engine Management

Fuel Metering Valves N290 and N402

The fuel metering valves are located at the sides of the high-pressure fuel pumps.

Task

They have the task of making the required quantity of fuel available at the required fuel pressure in the fuel rail pipe.

Effects in the Event of Failure

The metering valves are open when current is not supplied. This means that high pressure is not built-up and the engine runs with the existing fuel pressure from Transfer Fuel Pump G6. As a result, output and torque are significantly reduced.



Engine Management

Intake Camshaft Adjustment Valves N205 and N208

Exhaust Camshaft Adjustment Valves N318 and N319

These solenoid valves are attached to the cylinder head covers.

Task

Depending on actuation by the engine control unit, they distribute the oil pressure to the camshaft adjusters according to the adjustment direction and adjustment travel.

Both camshafts are infinitely adjustable:

- Intake camshaft, 42° crank angle
- Exhaust camshaft 42° crank angle
- Maximum valve overlap angle 47° crank angle

Camshaft Adjustment Valve N205 (Intake)



S388_041

Camshaft Adjustment Valve 1 N318 (Exhaust)

Effects in the Event of Failure

If an electrical cable to the camshaft adjusters is defective or a camshaft adjuster fails due to mechanical jamming or insufficient oil pressure, no further camshaft adjustment is carried out. Power and torque are reduced.

Camshaft Adjustment Valve 2 N208 (Intake)



S388_042

Camshaft Adjustment Valve 2 N319 (Exhaust)

Engine Management

Variable Intake Manifold Runner Motor V183

The variable intake manifold motor is bolted to the intake manifold.

Task

The motor is actuated by Engine Control Module J623 depending on engine load and speed. The motor actuates the change-over flaps via a shaft and switches to the torque (*long runners*) or the output position (*short runners*).

Effects in the Event of Failure

If Variable Intake Manifold Runner Motor V183 fails, intake manifold change-over is no longer possible. The intake manifold remains in the position in which the change-over flaps were located at the time of failure. Power and torque are reduced.

Variable Intake Manifold
Runner Motor V183



S388_043

Intake Flap Motor V157

The intake manifold flap motor is bolted to the variable intake manifold.

Task

The motor is actuated by Engine Control Module J623 depending on engine load and speed. Using two operating rods, it adjusts four intake manifold flaps per cylinder bank.

If these are actuated, they close part of the intake port in the cylinder head. This leads to circular air movement in the cylinder head and improves mixture formation.

Effects in the Event of Failure

If Intake Flap Motor V157 fails, the intake manifold flaps can no longer be actuated. This leads to a deterioration in combustion and a reduction in output and torque. The fuel consumption also increases.

Intake Flap
Motor V157



S388_044

Functional Diagram

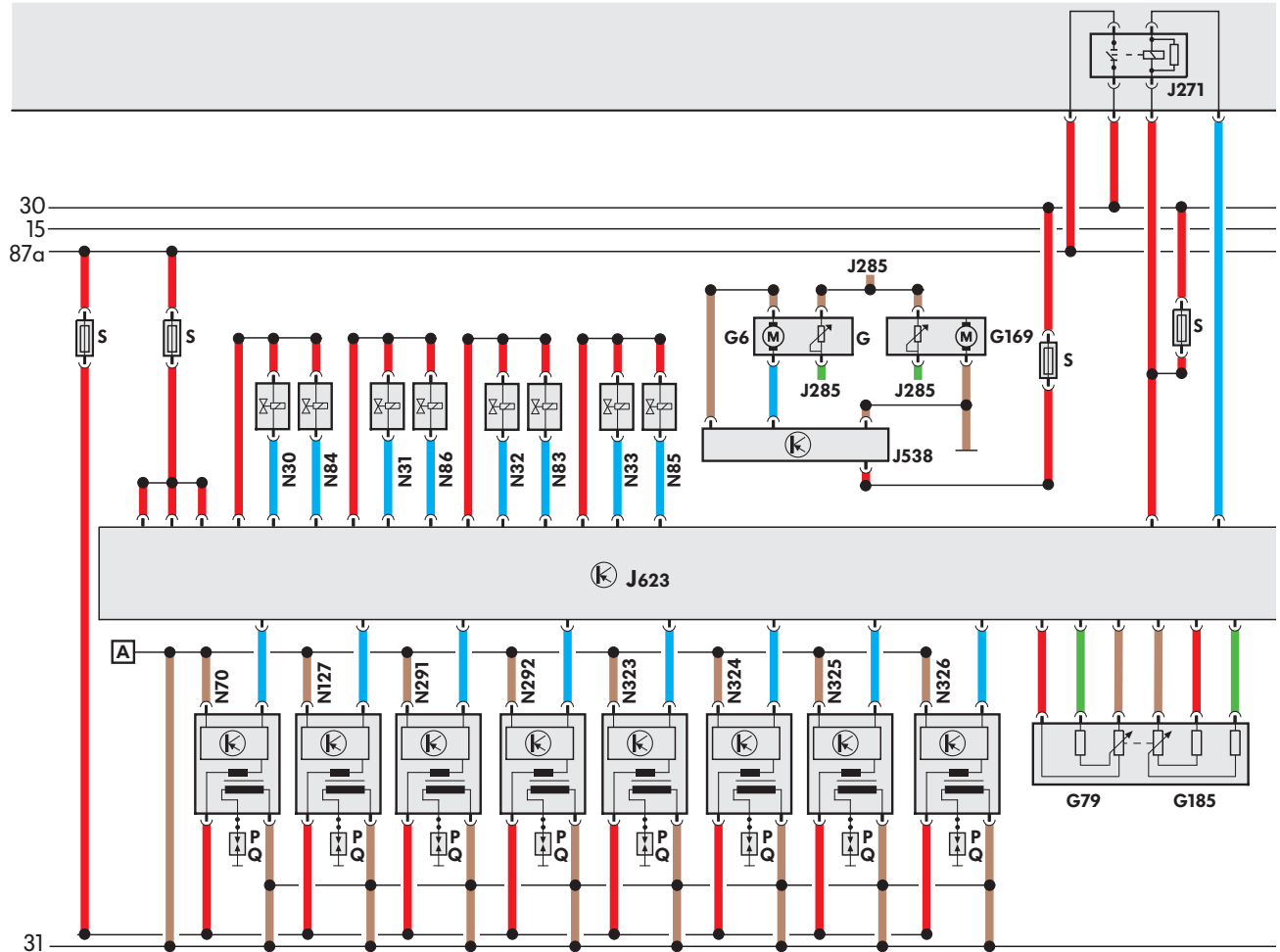

- | | | | |
|-------------|---|--------------|--|
| A | Battery | N70 | Ignition Coil 1 with Power Output Stage |
| G | Fuel Level Sensor | N83- | Cylinder 5 Fuel Injector to |
| G6 | Transfer Fuel Pump | N86 | Cylinder 8 Fuel Injector |
| G79 | Throttle Position (TP) Sensor | N127 | Ignition Coil 2 with Power Output Stage |
| G169 | Fuel Level Sensor 2 | N291 | Ignition Coil 3 with Power Output Stage |
| G185 | Accelerator Pedal Position Sensor 2 | N292 | Ignition Coil 4 with Power Output Stage |
| J271 | Motronic Engine Control Module (ECM) Power Supply Relay | N323- | Ignition Coil 5 with Power Output Stage to |
| J285 | Instrument Cluster Control Module | N326 | Ignition Coil 8 with Power Output Stage |
| J538 | Fuel Pump Control Module | P | Spark Plug Connector |
| J623 | Engine Control Module | Q | Spark Plugs |
| N30- | Cylinder 1 Fuel Injector to | S | Fuse |
| N33 | Cylinder 4 Fuel Injector | | |

Functional Diagram

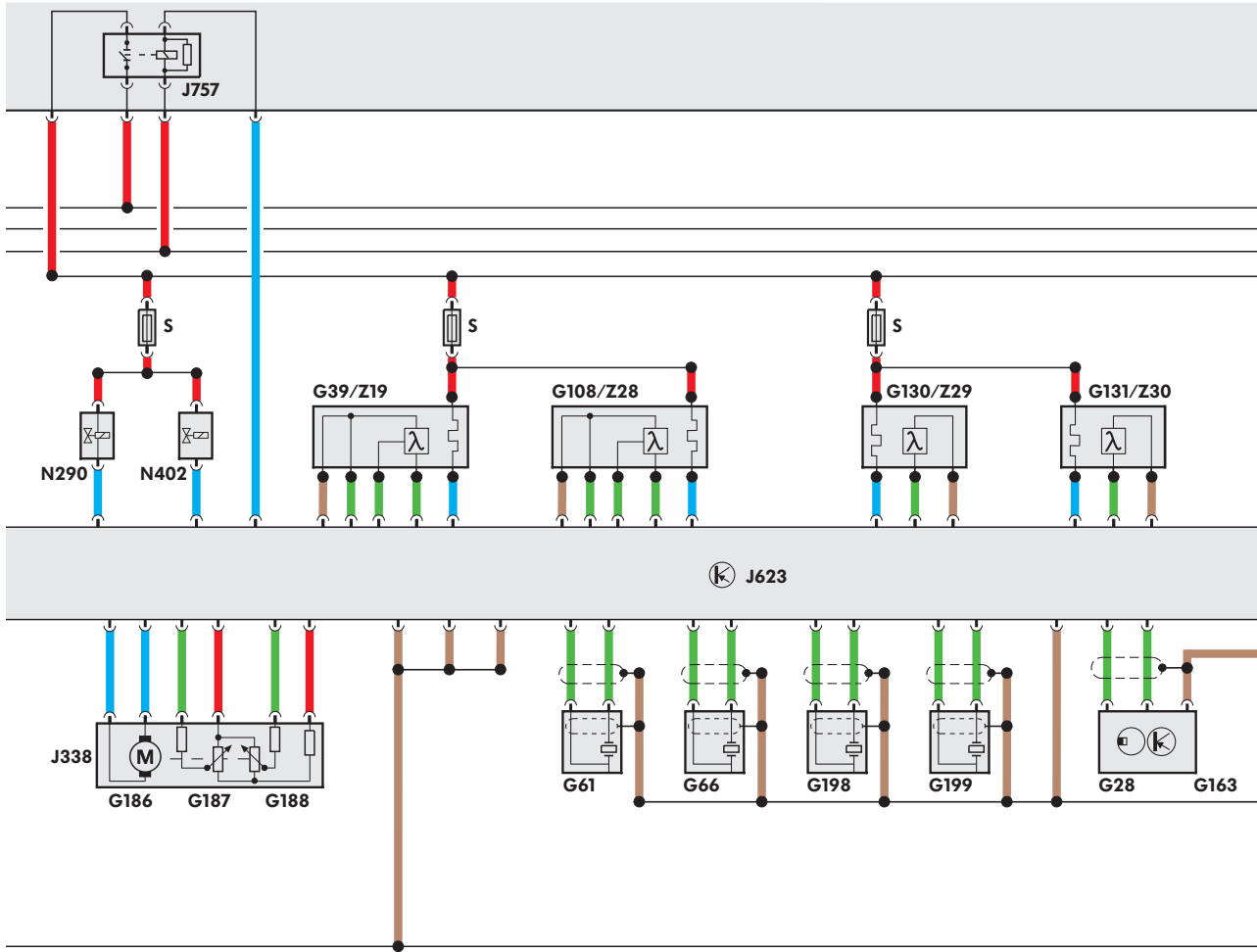

S388_045

- | | |
|--|--|
| G28 Engine Speed Sensor | J757 Engine Component Power Supply Relay |
| G39 Heated Oxygen Sensor (HO2S) | N290 Fuel Metering Valve |
| G61 Knock Sensor 1 | N402 Fuel Metering Valve 2 |
| G66 Knock Sensor 2 | S Fuse |
| G108 Heated Oxygen Sensor (HO2S) 2 | Z19 Oxygen Sensor (O2S) Heater |
| G130 Oxygen Sensor (O2S) Behind Three Way Catalytic Converter | Z28 Oxygen Sensor (O2S) Heater 2 |
| G131 Oxygen Sensor 2 (O2S) Behind Three Way Catalytic Converter | Z29 Oxygen Sensor (O2S) 1 (Behind Three Way Catalytic Converter) Heater |
| G163 Camshaft Position Sensor 2 | Z30 Oxygen Sensor (O2S) 1 (Behind Three Way Catalytic Converter) Heater |
| G186 Throttle Drive for Electronic Power Control (EPC) | Positive |
| G187 Throttle Drive Angle Sensor 1 for Electronic Power Control (EPC) | Ground |
| G188 Throttle Drive Angle Sensor 2 for Electronic Power Control (EPC) | Input Signal |
| G198 Knock Sensor 3 | Output Signal |
| G199 Knock Sensor 4 | Bi-Directional Cable |
| J338 Throttle Valve Control Module | CAN Data Bus |
| J623 Engine Control Module | |

Functional Diagram

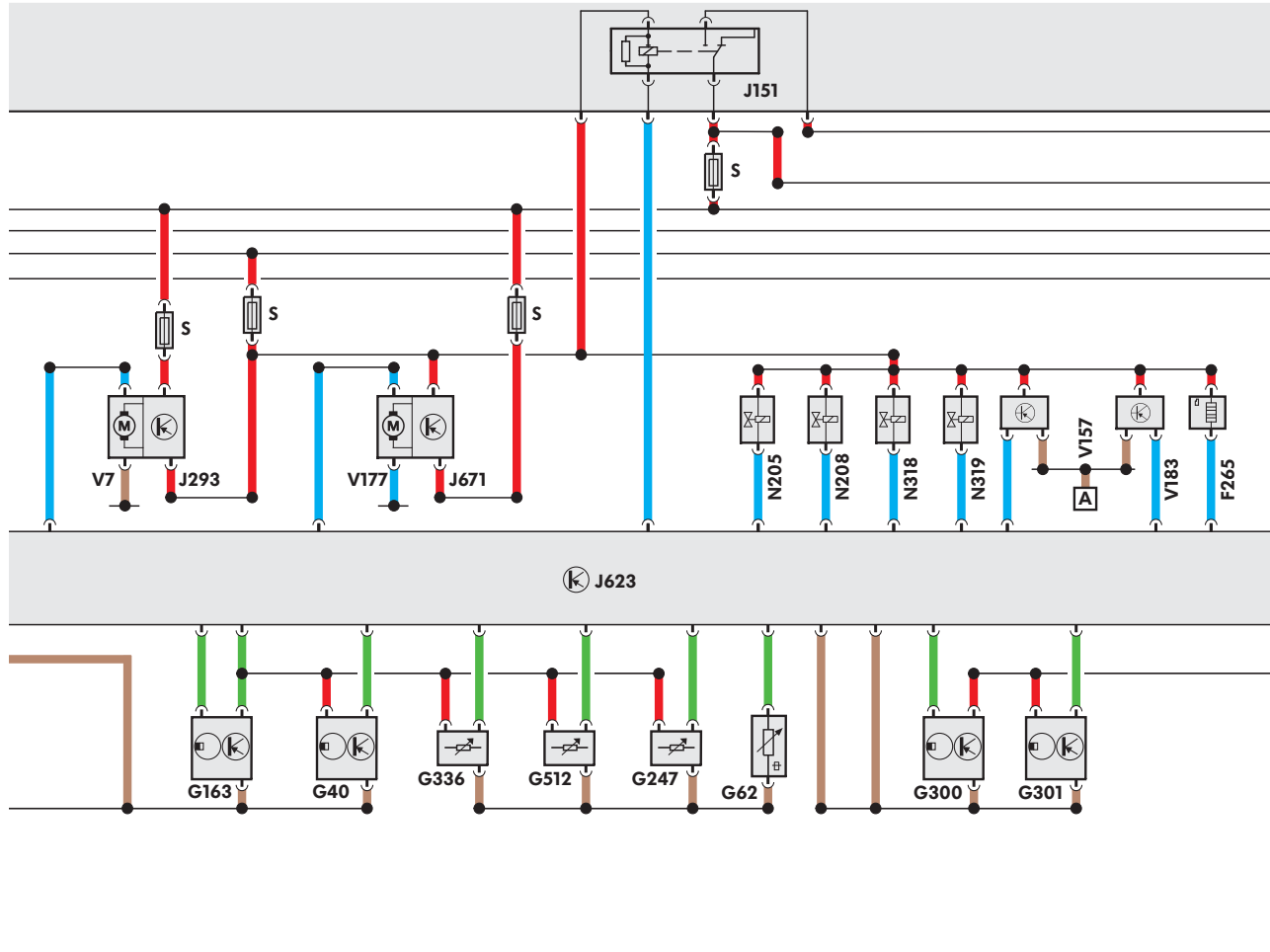

- | | | | |
|-------------|--|-------------|---|
| A | Battery | J293 | Coolant Fan Control (FC) Control Module |
| F265 | Map Controlled Engine Cooling Thermostat | J623 | Engine Control Module |
| G40 | Camshaft Position Sensor | J671 | Coolant Fan Control (FC) Control Module 2 |
| G62 | Engine Coolant Temperature Sensor | N205 | Camshaft Adjustment Valve 1 (Intake) |
| G163 | Camshaft Position Sensor 2 | N208 | Camshaft Adjustment Valve 2 (Intake) |
| G247 | Fuel Pressure Sensor | N318 | Camshaft Adjustment Valve 1 (Exhaust) |
| G300 | Camshaft Position Sensor 3 | N319 | Camshaft Adjustment Valve 2 (Exhaust) |
| G301 | Camshaft Position Sensor 4 | S | Fuse |
| G336 | Intake Manifold Runner Position Sensor | V7 | Coolant Fan |
| G512 | Intake Manifold Runner Position Sensor 2 | V157 | Intake Flap Motor |
| J151 | Coolant Circulation Pump Relay | V177 | Coolant Fan 2 |
| | | V183 | Variable Intake Manifold Runner Motor |

Functional Diagram

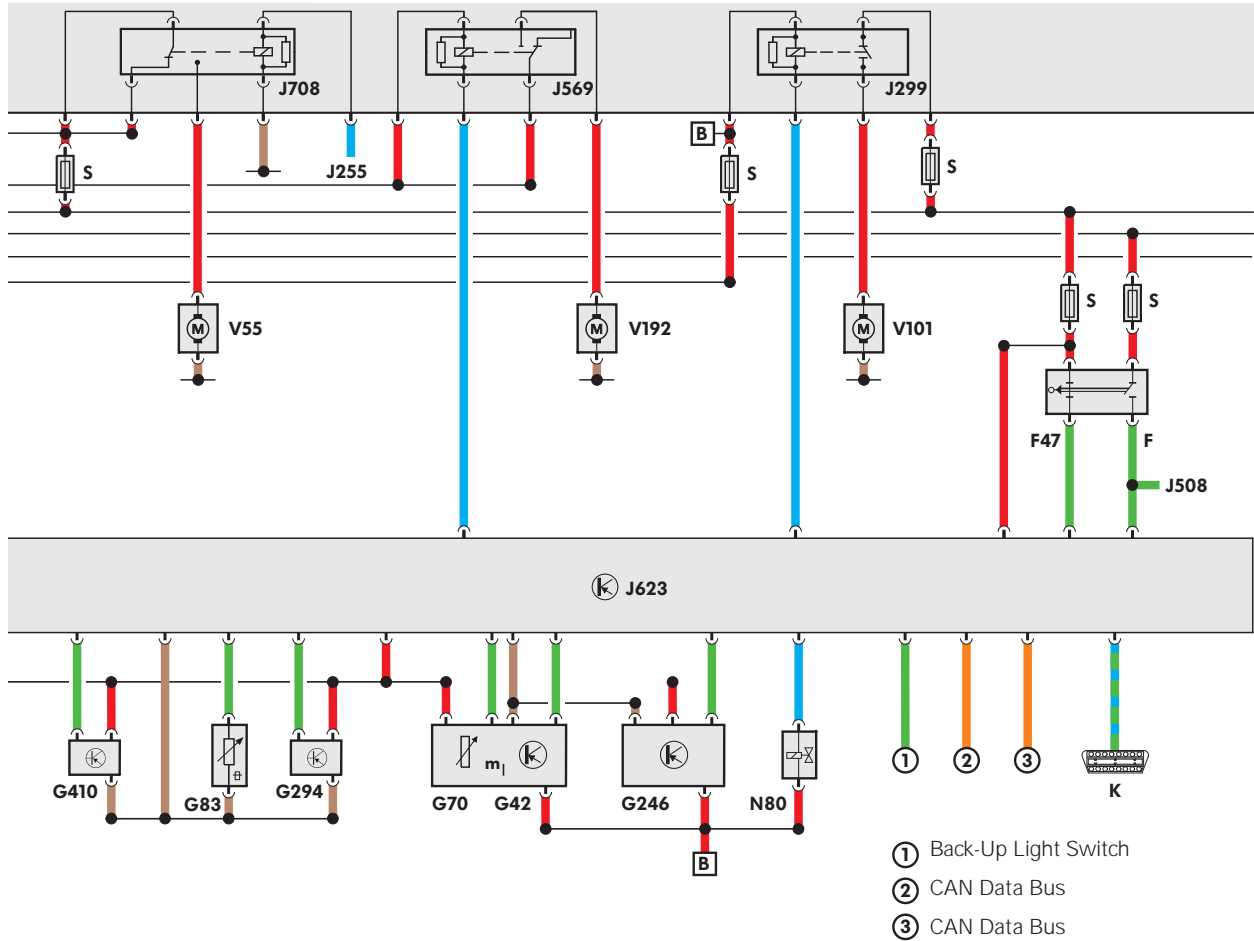





S388_045

- | | | | |
|-------------|---|-----------------------------|---|
| B | Starter | J623 | Engine Control Module |
| F | Brake Light Switch | J708 | Residual Heat Relay |
| F47 | Brake Pedal Switch | N80 | Evaporative Emission Canister Purge Regulator Valve |
| G42 | Intake Air Temperature Sensor | S | Fuse |
| G70 | Mass Air Flow Sensor | V55 | Recirculation Pump |
| G83 | Engine Coolant Temperature Sensor (on Radiator) | V101 | Secondary Air Injection Pump Motor |
| G246 | Mass Air Flow Sensor 2 | V192 | Brake System Vacuum Pump |
| G294 | Brake Booster Pressure Sensor | | |
| G410 | Low Fuel Pressure Sensor | | |
| K | Dash Panel Insert | | |
| J255 | Climatronic Control Module | | |
| J299 | Secondary Air Injection Pump Relay | | |
| J508 | Brake Light Disable Relay | | |
| J569 | Brake Booster Relay | | |
| | | Positive | |
| | | Ground | |
| | | Input Signal | |
| | | Output Signal | |
| | | Bi-Directional Cable | |
| | | CAN Data Bus | |

Service

Special Tools

Designation	Tool	Application
Thrust piece T 40051		For installing A/C compressor drive sealing ring
Thrust piece T40052		For installing power steering pump drive sealing ring
Camshaft clamps T40070		For locking camshafts on cylinder bank 1 and cylinder bank 2
Locking pins T40071		For locking chain tensioners for chain drives A, B, C, D
Key T40079		For pre-tensioning inlet and exhaust camshafts after installing the camshaft timing chain

Knowledge Assessment

An on-line Knowledge Assessment (*exam*) is available for this Self-Study Program.

The Knowledge Assessment may or may not be required for Certification.

You can find this Knowledge Assessment at:

www.vwwebservice.com

For Assistance, please call:

Volkswagen Academy

Certification Program Headquarters

1- 877-491-4838

(8:00 a.m. to 8:00 p.m. EST)

Or, E-Mail:

concierge@volkswagenacademy.com

822703

