

Service Training



Self Study Program 820233

# Basics of Electric Vehicles

Design and Function



Volkswagen Group of America, Inc.  
Volkswagen Academy  
Printed in U.S.A.  
Printed 7/2013

Course Number 820233

©2013 Volkswagen Group of America, Inc.

All rights reserved. All information contained in this manual is based on the latest information available at the time of printing and is subject to the copyright and other intellectual property rights of Volkswagen Group of America, Inc., its affiliated companies and its licensors. All rights are reserved to make changes at any time without notice. No part of this document may be reproduced, stored in a retrieval system, or transmitted in any form or by any means, electronic, mechanical, photocopying, recording or otherwise, nor may these materials be modified or reposted to other sites without the prior expressed written permission of the publisher.

All requests for permission to copy and redistribute information should be referred to Volkswagen Group of America, Inc.

Always check Technical Bulletins and the latest electronic repair information for information that may supersede any information included in this booklet.

Trademarks: All brand names and product names used in this manual are trade names, service marks, trademarks, or registered trademarks; and are the property of their respective owners.

# Contents

<b>Introduction</b> . . . . .	<b>1</b>
<b>Basics of Electromobility</b> . . . . .	<b>12</b>
<b>Vehicle Concepts</b> . . . . .	<b>28</b>
<b>High Voltage Safety</b> . . . . .	<b>40</b>
<b>Service</b> . . . . .	<b>48</b>
<b>Knowledge Assessment</b> . . . . .	<b>57</b>

This Self-Study Program provides information regarding the design and function of new models. This Self-Study Program is not a Repair Manual.

**This information will not be updated.** For maintenance and repair procedures, always refer to the latest electronic service information.





**Page intentionally left blank**

Unlike vehicles with combustion engines, electric vehicles do not produce exhaust gases during operation. This alone makes electric vehicles more environmentally friendly than vehicles with conventional technology. However, the electrical energy for charging the vehicle does have to be produced from renewable sources, e.g. from wind, solar, hydroelectric or biogas power plants.

By combining different drive types, the overall efficiency of the vehicle can be improved and fuel consumption can be reduced.

The 2011 Touareg was the first Volkswagen vehicle with an electric hybrid drive. The new technology requires special training for handling and working on high-voltage vehicles. This self-study program describes the realistic hybrid and electromobility concepts and the basics of high-voltage qualification for service staff.

# Introduction

## The History of Electromobility

Electromobility has always been an issue that has helped drive the development of vehicles. It did become less important for a while because the oil fields did not appear to be drying up, but now electromobility is becoming increasingly significant as people become aware of the depletion of oil reserves and the need for of global environmental and climate protection.

### 1821

Thomas Davenport builds the first electric car with a non-rechargeable battery and a range of 9 to 19 miles (15 to 30 km).

### 1881

The first officially recognized electric vehicle is a tricycle made by Gustave Trouvé in Paris. Using a rechargeable lead-acid battery, the vehicle can reach speeds up to 7.5 mph (12 km/h).

### 1898

A company belonging to Charles Jeantaud from Paris is the leader in the field of electromobiles at the turn of the century (1893 to 1906).

One of these vehicles sets a speed record by reaching 23.4 mph (37.7 km/h).

### 1902

A. Tribelhorn, a pioneering Swiss electromobility company, builds its first vehicles with an electric motor. Over a period of almost 20 years, the company produces mainly electrically powered commercial vehicles. They only manufacture passenger vehicles in small numbers and mainly as prototypes.



### 1860

The rechargeable lead-acid battery is invented.

### 1882

In this year, Ernst Werner Siemens builds an electrically driven carriage. This vehicle, which was also known as the "Elektro-Motte" or "Elektromote", is considered to be the world's first trolleybus.

### 1900

Ferdinand Porsche presents a vehicle with in-wheel motors on both wheels of the front axle at the world exhibition in Paris.

### 1913

The first gasoline station starts business in Pittsburgh (USA). Soon after, gasoline stations open in every town. A better infrastructure, cheap gasoline and the development of internal-combustion engines with greater ranges are all reasons for the success of vehicles with internal-combustion engines.

s499\_274

## 1960

Dr Charles Alexander Escoffery presents probably the world's first solar car. It is a Baker Electric from 1912 registered in California with a photovoltaic panel made up of 10,640 single cells.

## 1973

The first oil crisis shows the industrial nations how dependent they are on oil-exporting countries. Fuel prices rise drastically.

## 1987

The "World Solar Challenge," a competition for solar vehicles, is staged.

## 1992

German car manufacturer Volkswagen develops the VW Golf Citystromeer, a converted Golf that is equipped with an electric motor.

## 1996

General Motors offers the two seater electric coupé "EV 1" (Electric Vehicle 1) with 1,100 lb (500 kg) lead-acid batteries. Later nickel-metal hydride batteries improved the performance of the vehicle.

## 2009

The German government introduces the national electromobility development plan (Nationalen Entwicklungsplan Elektromobilität, NEPE). The goal is to promote the research and development, the market preparation and the launch of battery-powered vehicles in Germany. It is hoped there will be one million electric cars on German roads by 2020 and Germany will develop into the lead market for electromobility.



## 1969

The "Lunar Rover" is developed in the USA for the moon landings. It has an electric motor at each wheel. Two silver-zinc batteries are used as the power source giving the "Lunar Rover" a range of approximately 57 miles (92km).

## 1985

The world's first race for solar-powered cars, the "Tour de Sol", is staged in Switzerland.

## 1991

The THINK is one of the first cars to be conceived as a purely electric vehicle and not a conversion into an electric vehicle.

## 1995

PSA Peugeot Citroën builds 10,000 electric vehicles from 1995 to 2005.

## 2008

The exclusively electric-powered "Tesla Roadster" built by Tesla Motors is launched on the US market with 6,187 laptop batteries connected in series. It accelerates from 0 to 62 mph (100 km/h) in 3.8 seconds.

s499\_275

# Introduction

## History of Electromobility at Volkswagen

VW can look back on over 40 years of experience in electromobility. Back in 1970, the "T2 Electric" was the first generation of a purely electric vehicle.

T2 Electric



Golf 1 Electric



T3 Electric



Golf 3 City



### Electric Vehicles

Jetta CitySTROMer

1970

1975

1980

1985

1990

T2 City Taxi



Golf 1 Hybrid



Golf 2 Hybrid



Chico

### Hybrid Vehicles

### Vehicles with Fuel Cells



# Introduction

**STROMer**



**Golf TwinDrive**



**Electro Van**



**Electro UP**



**Golf blue-e-motion**



1995

2000

2010

2015

**Hybrid**



**Golf ECO Power**



**Touareg Hybrid**



**Bora HyMotion**



**Tiguan HyMotion**



**Bora HyPower**



**Touran HyMotion**



s499\_018

# Introduction

---

## Why is Electromobility Interesting?



s499\_276

For our study of the core aspects of electromobility, we have chosen the areas of environment, politics, economy, society, infrastructure and technology. It is not possible to completely separate the content of these areas because there are complex relationships between them.

Climate change and the conditions for the use of fossil resources (limited availability, price) are causing countries to change their climate and energy policies and are causing changes to their national societies.

Politicians are responding to these changes with national emissions limits that unfortunately vary at international level. As a rule, these limits cover direct emissions of CO<sub>2</sub> or other environmentally harmful gases.

Electric vehicles do not produce direct emissions in the form of CO<sub>2</sub>.

The introduction of low emissions or emissions-free zones in towns and a changed political framework will speed up the expansion of electromobility. State or municipal funding will stimulate the economy and support advances in science and research. An increasing number of companies are investing in electromobility and are improving existing concepts, technological innovations and their future applications in collaboration with researchers.

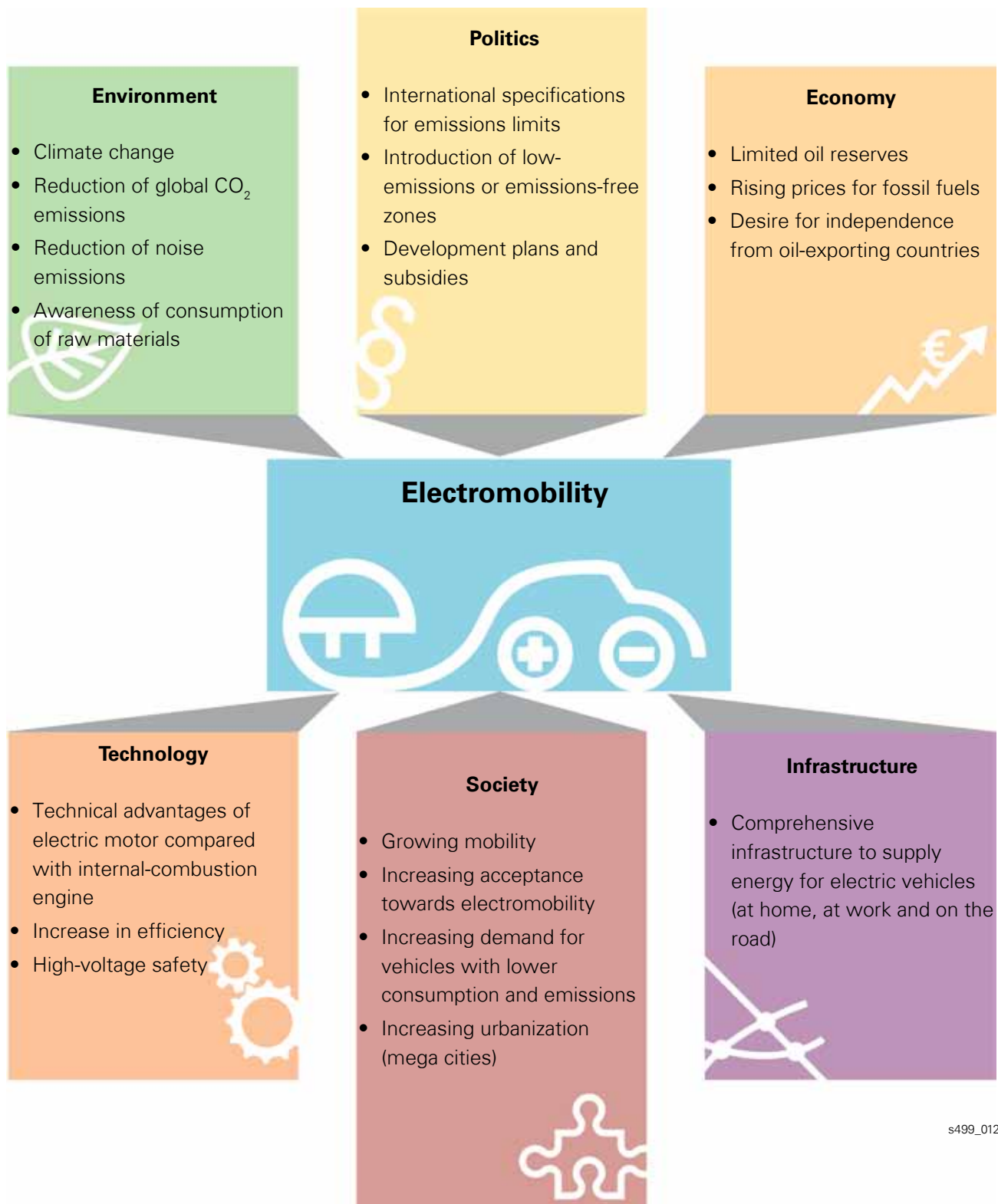

s499\_012

# Introduction

---

## Advantages of Electromobility

- Electric drive motors run quieter than internal-combustion engines. The noise emissions from electric vehicles is very low. At high speeds, the rolling noise from the tires is the loudest sound.
- Electric vehicles produce no harmful emissions or greenhouse gases while driving. If the high-voltage battery is charged from renewable energy sources, an electric vehicle can be run CO<sub>2</sub>-free.
- In the near future, if particularly badly congested town centres are turned into zero-emissions zones, we will only be able to drive through them with high-voltage vehicles.
- The electric drive motor is very robust and requires little maintenance. It is only subject to minor mechanical wear.
- Electric drive motors have a high degree of efficiency of up to 96% compared with internal-combustion engines that have an efficiency of 35–40%.
- Electric drive motors have excellent torque and output characteristics. They develop maximum torque from standstill. This allows an electric vehicle to accelerate considerably faster than a vehicle with an internal combustion engine producing the same output.
- The drive train design is simpler because vehicle components like the transmission, clutch, mufflers, particulate filters, fuel tank, starter, alternator and spark plugs are not required.
- When the vehicle is braked, the motor can also be used as an alternator that produces electricity and charges the battery (regenerative braking).
- The high-voltage battery can be charged at home, in a car park and by using any accessible sockets. The blue charging connector on the vehicle and on public charging stations has been standardized across Germany and is used by all manufacturers.
- The energy is only supplied when the user needs it. Compared with conventional vehicles, the electric drive motor never runs when the vehicle stops at a red light. The electric drive motor is highly efficient particularly in lines and bumper-to-bumper traffic.
- Apart from the reduction gearbox on the electric drive motor, the electric vehicle does not require any lubricating oil.

## Disadvantages of Electric Vehicles

- Electric vehicles have a limited range due to battery size and construction.
- Charging a high voltage battery can take a long time, depending on the battery charge and power source.
- The network of electric charging stations is sparse.
- If the destination is beyond the range of the electric vehicle, the driver will need to plan the journey. "Where can I charge my electric vehicle on the road?"

## Comparison of Torque Development

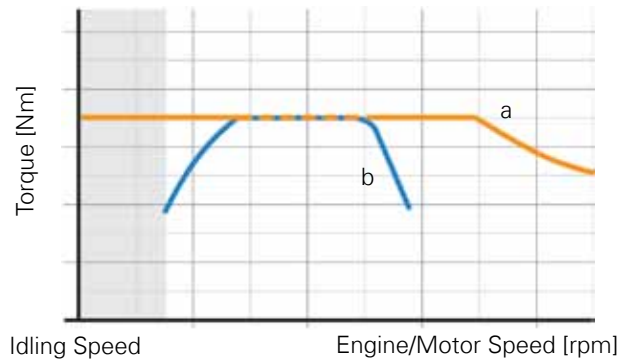

- Electric Drive Motor (a)
- Internal-Combustion Engine (b)

s499\_251

## Electric Drive Motor

The electric drive motor (a) reaches its maximum torque as early as the first revolution. It does not require a start-up phase to reach idling speed.

Once a specific rpm figure has been reached, the available torque falls as the revs increase. This motor speed is approximately 14,000 rpm.

These characteristics of an electric drive motor mean that a complex transmission is not required.

## Internal-Combustion Engine

The internal-combustion engine (b) requires an idling speed to produce a torque. The available torque increases when the engine speed is increased. In addition, this characteristic of the internal-combustion engine requires a transmission with several gear ratios. The torque is transferred to the transmission via a clutch or a torque converter.

# Introduction

## Environmental Aspects

### CO<sub>2</sub> Emissions

Before 2050, global warming should not exceed the value of 3.6° F (2°C) related to the earth's temperature from pre-industrial times. This goal can only be achieved by reducing CO<sub>2</sub> emissions. The plan is to reduce the CO<sub>2</sub> emissions per capita from the current 45 tons per year to 0.7 tons per year by 2050.

Electric vehicles do not directly produce CO<sub>2</sub> emissions. However, the analysis of CO<sub>2</sub> producers does not just evaluate the vehicle, but also the emissions that occur during the production of the electrical energy (e.g. in coal power stations).

In Germany in particular, electromobility is closely linked to the use of “clean electricity” (i.e. from renewable energy). It can be assumed that today's electricity mixture causes lower CO<sub>2</sub> emissions per vehicle compared with vehicles with internal-combustion engines. Analyzing the electricity mixture at international level is less favorable. The environmental balance of the electricity generation in threshold countries like China and India is not so good since they mainly rely on electricity generated from coal due to the rapidly rising demand for energy.

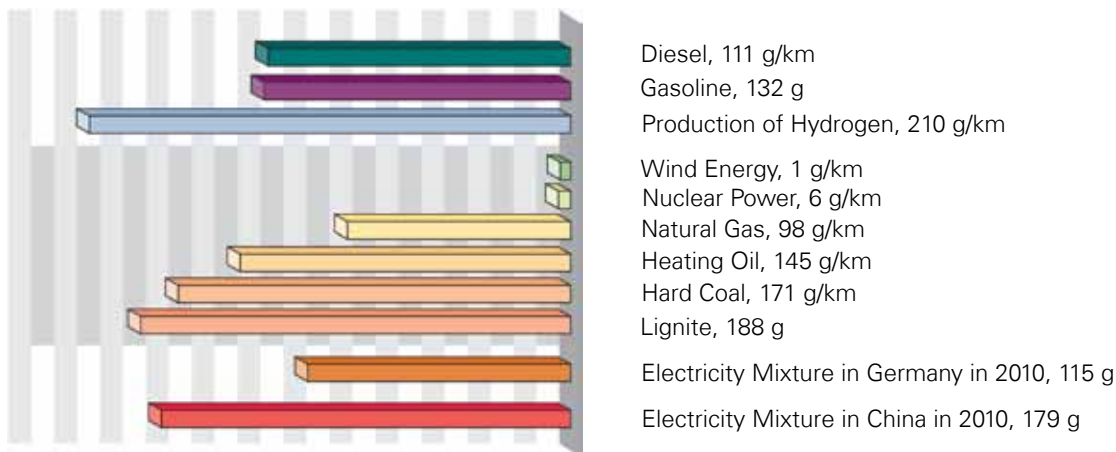

s499\_014

All figures: Grams of CO<sub>2</sub> per kilometer driven (as of 2011)



#### Did you know?

Since the pure hydrogen required for a fuel cell does not exist in nature, it must be produced using a complex process. This process requires a large amount of electrical energy.

## Renewable Energy

Renewable energy sources are energy sources that will be available in inexhaustible supply in the short run by human standards. Renewable energy sources include wind power, solar power, geothermics (terrestrial heat), hydropower and biomass.

A further reduction of CO<sub>2</sub> emissions in the electromobility field will be possible when the share of renewable energy sources is expanded in the electricity mixture. This share of European electricity production should rise to 48% by 2030 compared with the 17% in 2010.

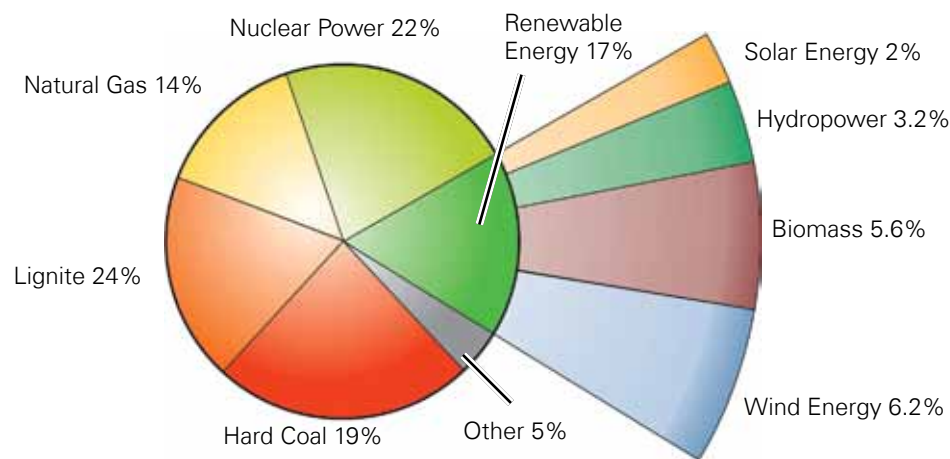

s499\_072

**Electricity Mixture in Germany in 2010**

## Potential of Solar Energy

The solar energy shining onto the earth corresponds to about ten thousand times today's total global energy requirement. Sunlight can provide more energy than we will need in the future. However, the costs and efficiency of solar cells stand in the way of the development of this potential. While the efficiency of the photovoltaic modules was around eight percent at the start of the eighties, the average modules currently on the market reach 17% and the leading-edge products almost 20%. In order for solar energy to be able to compete with other energy sources, solar power plants need to be made more efficient.



### Did you know?

Within 24 hours, the amount of energy that reaches the earth around the world in the form of sunlight is enough to supply the world's population with electrical energy for a year. The share of geothermics (the use of heat in the earth's crust) in the generation of electricity is still smaller than 1% in Germany in 2011.

# Basics of Electromobility

The topic of “electromobility” basically refers to all vehicles that are driven by means of electrical energy. This includes both battery-powered vehicles and hybrid vehicles (full hybrid vehicles) or vehicles with a fuel cell.

Electric vehicles are categorized primarily according to concept and their names indicate how the electrical energy is supplied.

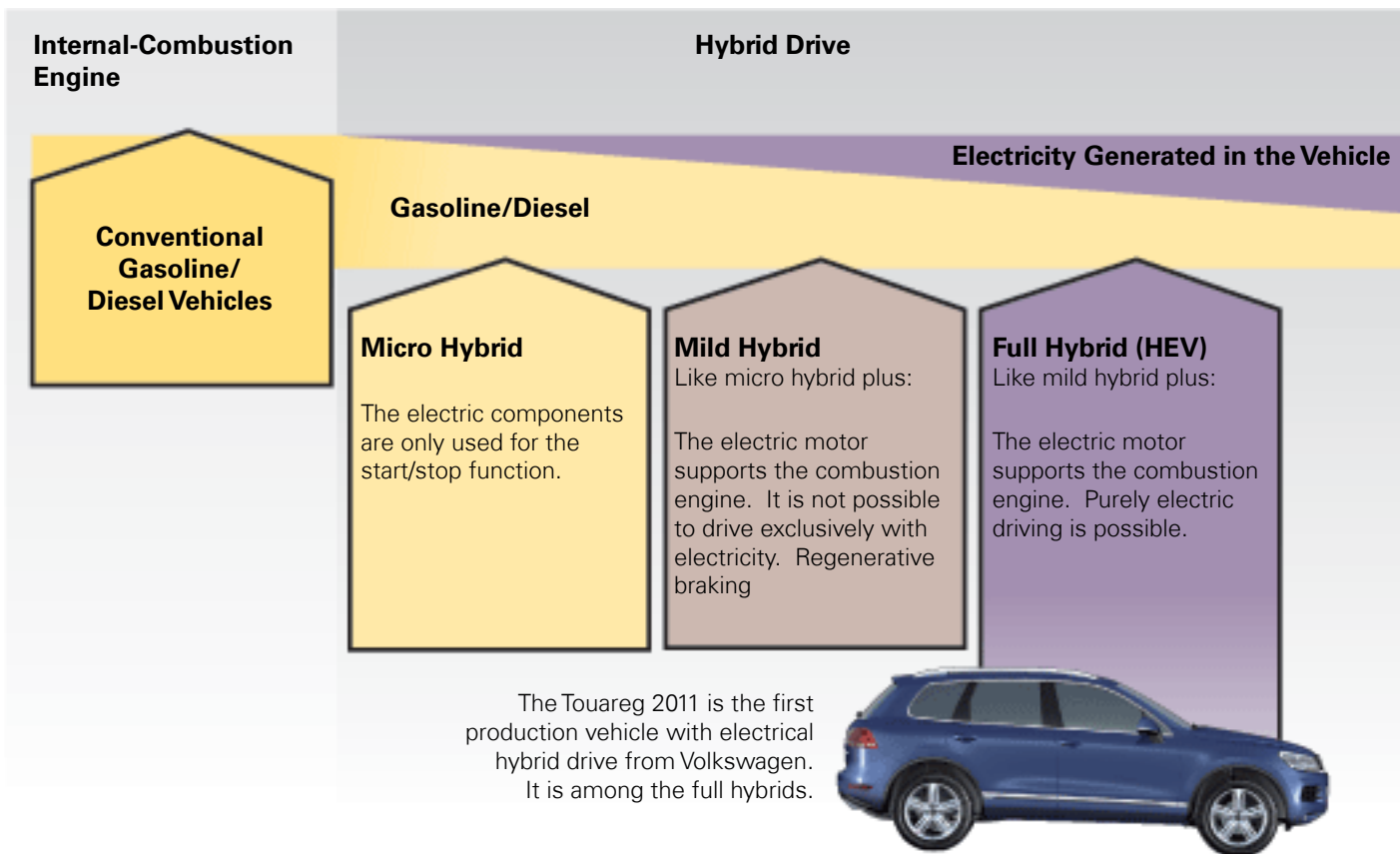



# Basics of Electromobility

## Terminology

- Emission-free vehicles that do not release exhaust gases into the environment during operation are also called “zero-emission vehicles” (ZEV).
- Battery-powered vehicles that are moved exclusively by an electric drive are also called “battery electric vehicles” (BEV). The energy required to run the vehicle is supplied by a high-voltage battery that is charged externally.

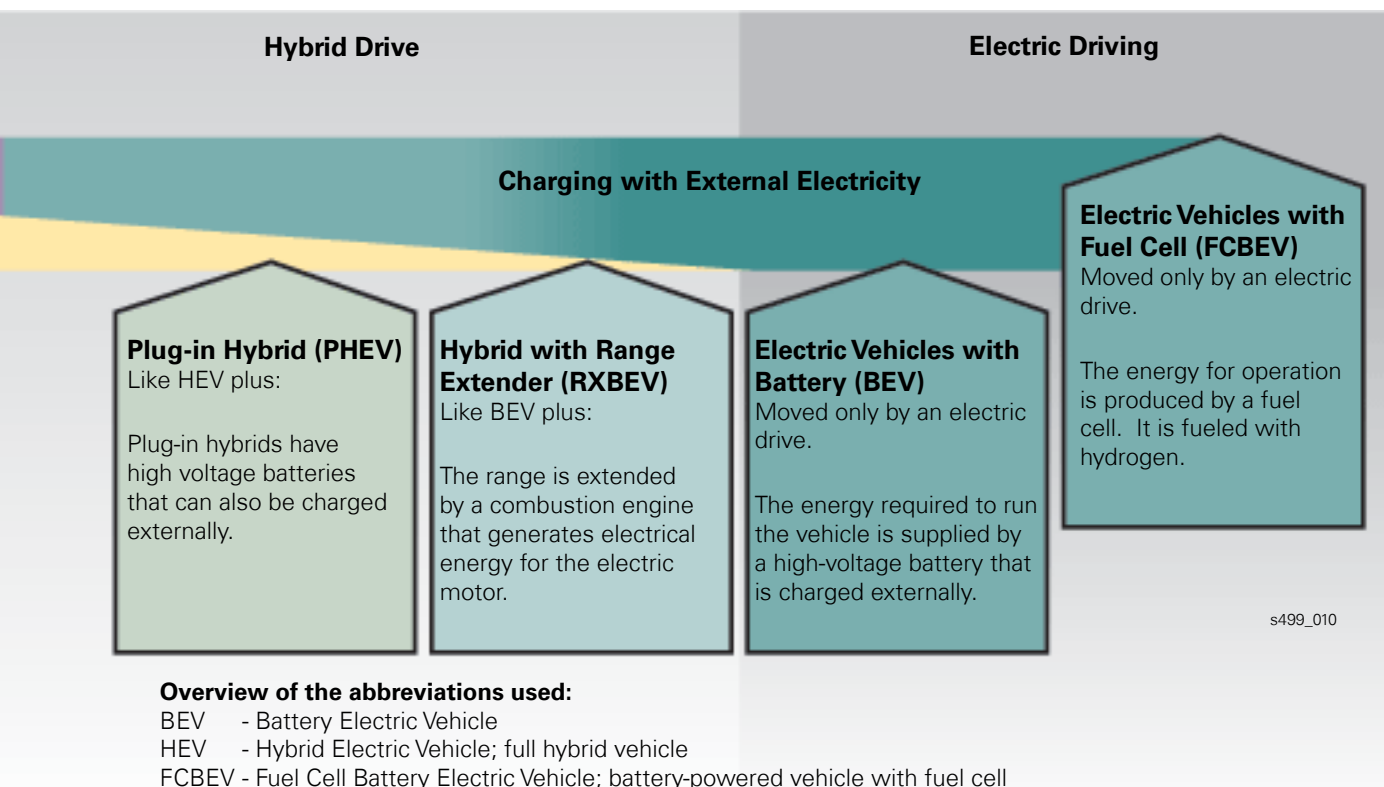

### Overview of the abbreviations used:

BEV - Battery Electric Vehicle

HEV - Hybrid Electric Vehicle; full hybrid vehicle

FCBEV - Fuel Cell Battery Electric Vehicle; battery-powered vehicle with fuel cell

PHEV - Plug-in Hybrid Electric Vehicle; vehicle with full hybrid drive and external charging facility

RXBEV - Range Extender Battery Electric Vehicle; battery-powered vehicle with additional generator drive to increase range (range extender)

# Basics of Electromobility

## The Main Components of an Electric Vehicle

The electric vehicle drive system includes:

- High-voltage battery with control unit for battery regulation and charger
- Electric motor/generator with electronic control (power electronics) and cooling system
- Transmission including the differential
- Brake system
- High-voltage air conditioning for vehicle interior climate control

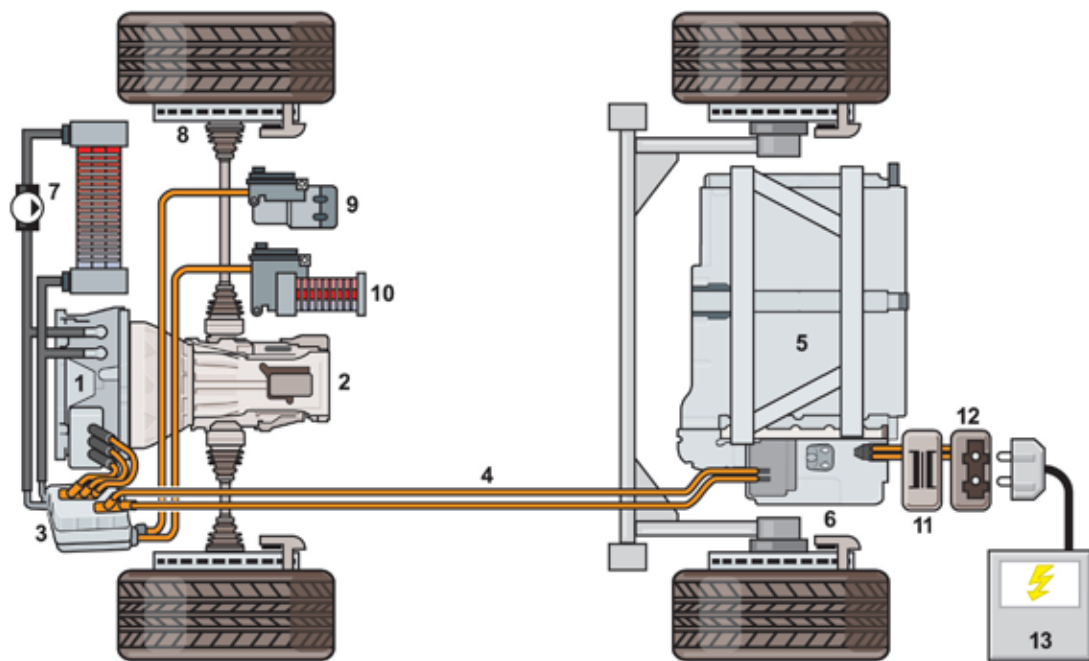

s499\_233

- 1 Electric motor/generator
- 2 Transmission with differential
- 3 Power electronics
- 4 High-voltage lines
- 5 High-voltage battery
- 6 Electronics box with control unit for battery regulation
- 7 Cooling system
- 8 Brake system
- 9 High-voltage air conditioner compressor
- 10 High-voltage heating
- 11 Battery charger
- 12 Charging contact for external charging
- 13 External charging source

# Basics of Electromobility

## The Electric Motor/Generator

The term electric motor/generator is used instead of alternator, electric motor and starter. In principle, any electric motor can also be used as an alternator. When the electric motor/generator is driven mechanically, it supplies electrical energy as an alternator. When the electric motor/generator is supplied with an electrical current, it works as a drive. Electric motors/generators used for propulsion are water-cooled. Air cooling would also be possible but complex due to space and the amount of heat generated.

In full hybrid vehicles (HEV), the electric motor/generator also functions as the starter for the combustion engine.



s499\_235

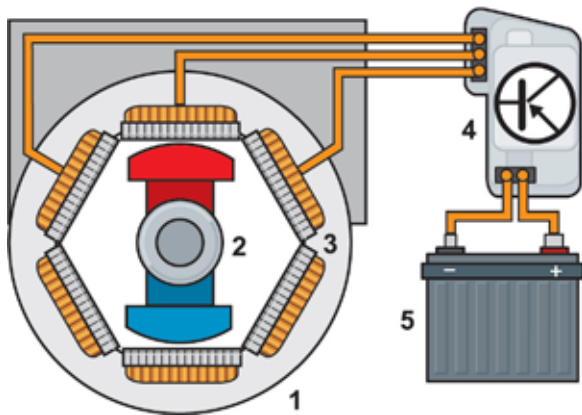

s499\_234

- Electric motor/generator (1)
- Rotor (2)
- Stator (3)
- Power electronics (4)
- High-voltage battery (5)

Three-phase synchronous motors are often used as the electric motor/generator. A three-phase motor is powered by a three-phase alternating current. It works with three coils that are arranged in a circle around the rotor to form the stator and are each electrically connected to one of the three phases. Several pairs of permanent magnets are located on the rotor in this synchronous motor. Since the three coils are supplied sequentially with a current, together they generate a rotating electrical field that causes the rotor to rotate when the electric motor/generator is used to drive the vehicle. When used as an alternator, the movement of the rotor induces a three-phase alternating voltage in the coils that is transformed into a direct voltage for the high-voltage battery in the power electronics.

Normally so-called "synchronous motors" are used in vehicles. In this context, the term "synchronous" means "running in synchronism" and refers to the ratio of the rotation speed of the energised field in the stator coils to the rotation speed of the rotor with its permanent magnets.

The advantage of synchronous motors compared with asynchronous motors is the more precise control of the motor in automobile applications.

# Basics of Electromobility

## Strengths of the Electric Motor/Generator

The electric motor/generator is very environmentally compatible thanks to the lack of noise and harmful emissions. The electric motor/generator responds quickly, has good acceleration figures and a high level of efficiency. In contrast to combustion engines, electric motors supply their nominal power steplessly over a broad rpm range. The maximum torque is available even at low rpm (i.e. when pulling away) and only drops once the motor reaches very high speeds. As a result, neither a manually operated transmission, an automatic transmission nor a clutch are required.

The direction of rotation of an electric drive motor is freely selectable. It can turn clockwise to move the vehicle forwards and counter-clockwise to reverse it.

Electric motors start automatically. A separate starter motor is not required. Electric motors have a simpler design and have considerably fewer moving parts than internal-combustion engines. Only the rotor with its permanent magnets rotates inside the electric motor/generator. There are no vibrating masses as in internal-combustion engines. Oil changes are not necessary as lubricating oil is not required. Consequently electrically powered vehicles are low-maintenance in terms of their drive unit.

## The High-Voltage Battery

The battery is the heart of electric vehicles. The high voltage battery supplies its direct voltage to the power electronics.

The power electronics convert the direct voltage into an alternating voltage and supply the electric motor/generator with three electrical phases via the three wires (U, V and W).

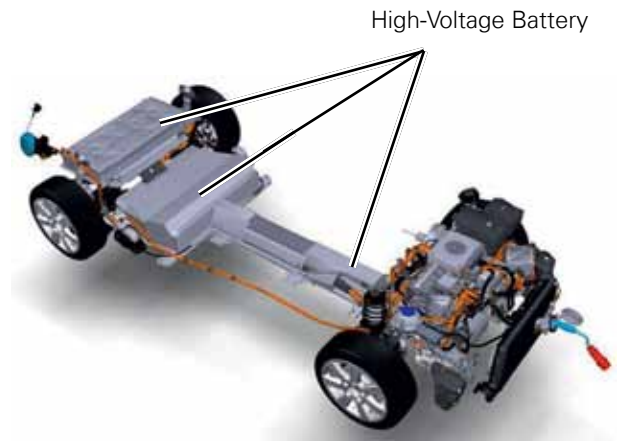

s499\_252

# Basics of Electromobility

## Explanation of terms

The term accumulator is sometimes used for rechargeable batteries. Originally batteries and accumulators were two different types of storage media for electrical energy. Today, the term “rechargeable battery” is generally used.

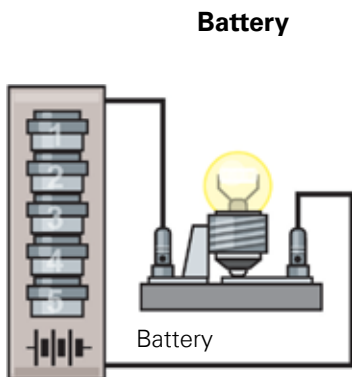

s499\_231

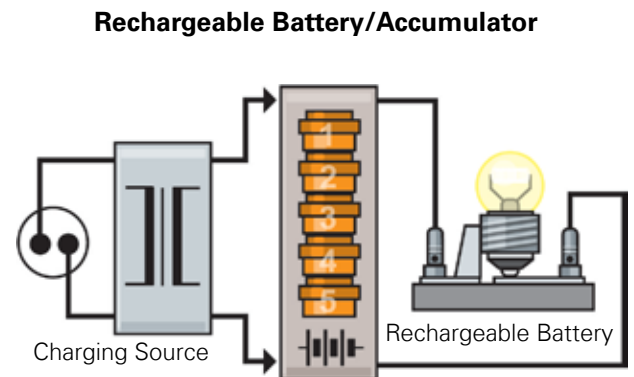

s499\_232

The term “battery” refers to a storage device for electrical energy that cannot be recharged. The battery is made up of primary cells.

The total voltage depends on the number and voltage of the individual cells.

A primary cell releases the chemical energy it has stored as electrical energy in a chemical reaction. The original charge state cannot be restored by electrical recharging.

A rechargeable battery is made up of secondary cells. The most familiar rechargeable battery is the lead-acid battery that is commonly used as a car battery.

As with non-rechargeable batteries, the available quantity of energy is determined by the number of secondary cells that are connected to each other.

In contrast with the primary cell battery, the chemical reaction that occurs here is easy to reverse. This means you can recharge the discharged battery with energy using a charger.



### Did you know?

The cycle stability of laptop batteries and mobile telephone batteries is around 500 cycles. This means that these batteries can be charged from flat to full up to 500 times. After that, these batteries only have approximately 50% of their original capacity. The capacity is given as the “State of Capacity” (SOC). The SOH (State of Health) indicates the “health” of the battery.

# Basics of Electromobility

---

In the following section, the term high-voltage battery (HV battery) is used for a rechargeable battery that supplies electricity to the electric motor/generator.

## Energy Density

This figure indicates the performance of a battery related to its weight. The higher the energy density, the more energy can be stored and then released again. The unit of energy density is watt hours per kilogram [Wh/kg] and is calculated from the electrical work [Wh] and the weight [kg] of the battery. The range of an electric vehicle can be determined from the energy density.

## Life

The cycle stability of a high-voltage battery is set at a total of 3,000 cycles over a period of 10 years, i.e. 300 cycles/year. On the basis of this property, so-called "automotive batteries"; i.e. batteries for use in a high-voltage vehicle, cannot be compared with the "consumer batteries" used in laptops or mobile telephones.

## Efficiency

The efficiency indicates how much of the energy that is invested into charging can be made useful again when the battery is discharged. A battery can never have 100% efficiency since a small part of the charging energy is released in the form of heat (charge loss).

# Basics of Electromobility

## Functional Principle

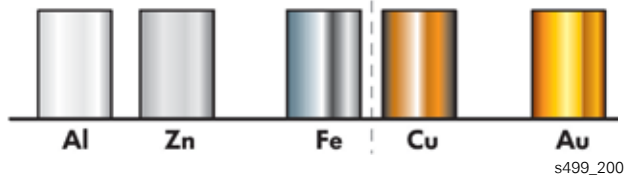

Excerpt from electro-chemical series of metals:  
Al - Aluminium  
Zn - Zinc  
Fe - Iron  
Cu - Copper  
Au - Gold

The function of a battery is based on the fact that metals have different levels of electrode potential. With batteries, the term potential means that two metals like zinc and copper differ in their chemical ability to release electrons.

The elements can be arranged in an electro-chemical series on the basis of this chemical property. Zinc releases electrons easily. This means it is easy to oxidize. Copper does not give up electrons for a chemical reaction so easily. This means it is more difficult to oxidize.

If you hang a zinc rod and a copper rod in an electrolytic solution in separate containers, both metals release ions into the electrolytes at different rates and leave electrons in the metal rod. In one container there are many positive zinc ions in the solution and many electrons in the zinc rod. In the other container, there are only a few positive copper ions in the solution and a few electrons in the copper rod. If both containers are now connected to each other by an ion bridge, a charge exchange occurs due to the different ion concentrations. Due to the high excess of electrons in the zinc rod, it acts as an anode while the copper rod forms the cathode. A voltage can be measured between the two due to the different electron concentrations.

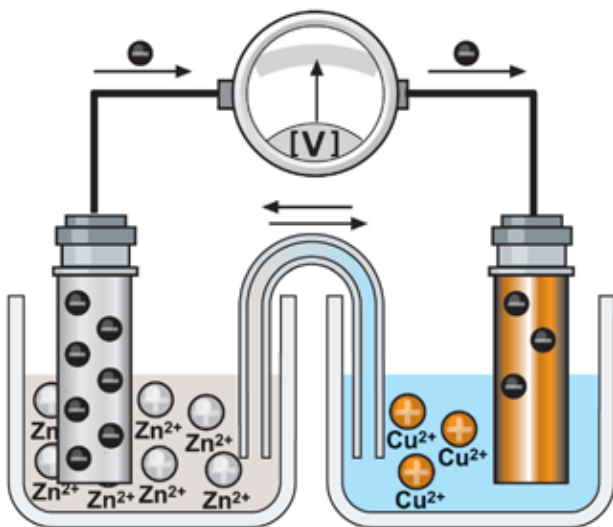

Schematic diagram of a battery

s499\_230

If you connect both electrodes with a conductor, the electrons will flow from the anode to the cathode. This set-up is generally called a galvanic cell and is the simplest form of a battery. If energy is released from the battery, the anode is the minus pole. In rechargeable batteries, the same electrode can alternately work as the anode or cathode depending on whether the battery is being charged or discharged.

# Basics of Electromobility

## Types of Rechargeable Battery

The different types of rechargeable batteries are distinguished by the materials used for the electrodes and electrolytes. The most common rechargeable batteries are lead-acid, nickel-cadmium, nickel-metal hydride and lithium-ion batteries.

### Lead-Acid Battery

The traditional 12 V vehicle electrical system battery has plates made from lead and lead/lead oxide and are used as electrodes. Sulfuric acid is the electrolyte.

- Requires maintenance (distilled water needs to be added to ensure the required electrolyte liquid level)
- Not well suited for powering electric vehicles because they are very heavy and large, reducing the load capacity
- Can lose a large part of its capacity after just six years
- If damaged, electrolyte (acid) can leak

### Nickel-Cadmium Battery

Cadmium (Cd) and a nickel compound are used for the electrodes in these batteries. Potassium hydroxide is used as the electrolyte.

- Also called an alkaline battery
- Has a higher energy density than lead acid batteries
- Less prone to damage and electrolyte leaks
- Subject to a memory effect. This type of battery can tolerate deep-discharging or overcharging only to a certain extent without becoming less efficient
- Cadmium and cadmium compounds are poisonous

### Nickel-Metal Hydride Battery

These batteries use a nickel compound and a compound of another metal for the electrodes. Potassium hydroxide is the electrolyte. They have a higher energy density than Ni-Cd batteries and are relatively resistant to damage.



# Basics of Electromobility

Even if a memory effect does not occur to the extent of the Ni-Cd batteries, these batteries also lose efficiency over the course of their life. To a certain extent, this loss in efficiency is reversible. Nickel metal hydride batteries do not contain any poisonous heavy metals like lead or cadmium. The electrolyte is stored in the battery in solid form. If the housing is broken, only a few droplets will escape.

## Lithium-Ion Battery

This battery uses lithium metal oxides and graphite for electrodes. Different solvents for lithium salts form the electrolyte. Lithium ion batteries contain only a small amount of water and do not have a memory effect. Compared with the nickel cadmium batteries, they have more than twice as much energy density. This means that this battery type requires less space in an electric vehicle leaving more room for the occupants and the luggage compartment.

<b>Density</b>	0.534g/cm <sup>3</sup> (in comparison: H <sub>2</sub> O = 1g/cm <sup>3</sup> )
<b>Usage in Batteries</b>	In form of lithium-carbonate (Li <sub>2</sub> CO <sub>3</sub> ); approx. 3 kg of pure lithium are required to build a battery delivering 20 kWh
<b>Advantages</b>	Quick charging due to low ion radius. No memory effect



If lithium-ion batteries are exposed to high temperatures, decomposition processes can result in the battery. This can lead to fire or the emission of dangerous gases. The manufacturer's warranty should always be observed when working with these batteries.

# Basics of Electromobility

## Fuel Cell

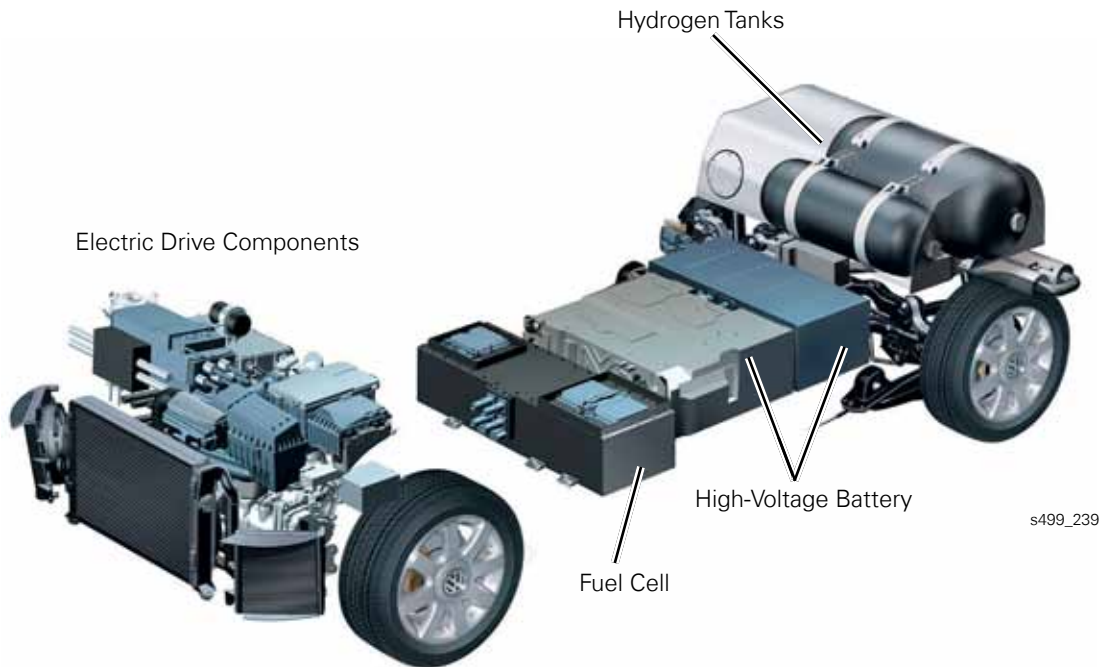

The fuel cell is another alternative energy device. The process that takes place in the fuel cell to produce electrical energy from chemical energy is similar to a combustion engine. The energy conversion from “fuel” to output is much more direct with the fuel cell. The efficiency of a fuel cell is greater than a combustion engine.

In a combustion engine, the chemical energy that is contained in the fuel molecules is converted into kinetic energy by combustion. This can then be used to drive a transmission or supply an alternator. In a combustion engine, a large amount of energy is converted into heat due to friction. In the fuel cell, chemical energy is converted into electrical energy. No alternator is required to generate electrical energy.

The fuel is industrially manufactured hydrogen. The fuel cell converts this to water using oxygen from the air. Hydrogen does have less energy than the hydrocarbons contained in fuel, but it is easier to combust and there are only small losses in the energy conversion. There is no combustion residue or exhaust gases.

# Basics of Electromobility

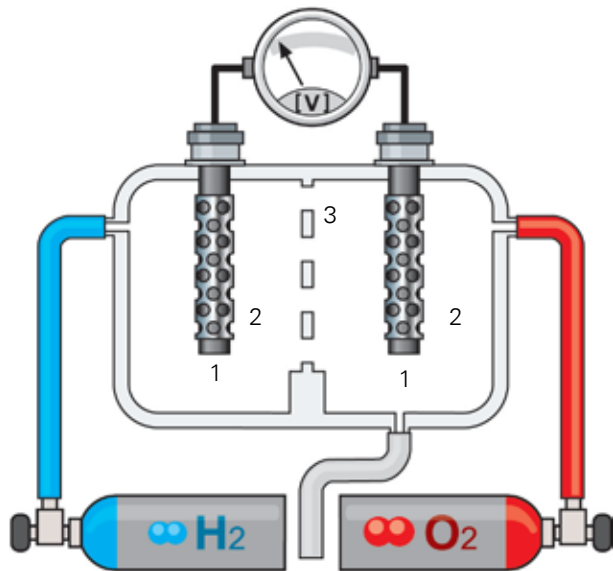

s499\_238

**Schematic Diagram of a Fuel Cell**

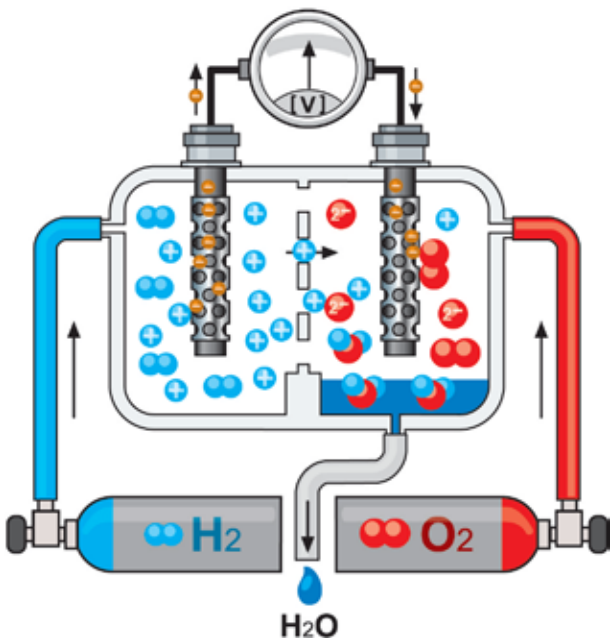

s499\_237

**Electricity is Generated by Burning Hydrogen.**

## Structure of a Fuel Cell

A hydrogen/oxygen fuel cell is a special form of galvanic cell. The main components are two electrodes (1) e.g. nano tubes made from carbon with a platinum coating that serves as a catalyst (2) and a special membrane (3). Various compounds can be used as the electrolyte. The special membrane is gas tight, non-conductive for electrons and permeable for protons (hydrogen nuclei without electrons). The oxygen ( $O_2$ ) comes from the ambient air.

## How it Works

Electrical energy is produced directly in the fuel cell from the conversion of hydrogen into water.

Hydrogen ( $H_2$ ) and oxygen ( $O_2$ ) are sent separately to the two electrodes: the hydrogen to the anode (A) and the oxygen to the cathode (C). The hydrogen releases two electrons with the help of the catalyst and splits into two positively charged hydrogen nuclei (protons). These can penetrate the membrane and pass through it because there are fewer protons in the electrolyte on the other side of the membrane (cathode side) than on the anode side (diffusion). The oxygen absorbs electrons catalytically at its electrode and then immediately reacts with the free hydrogen protons to form water ( $H_2O$ ).

If the anode and cathode are connected to each other electrically, a current flows due to this reaction (4).

# Basics of Electromobility

---

## Further High-Voltage Components

### Inverter

It has the job of converting the 3-phase alternating voltage of the alternator into a direct voltage for charging the battery. The three phases of the alternating voltage are first commutated and then smoothed in order to obtain an almost constant direct voltage. In the reverse case, the direct voltage from the battery is converted into a 3-phase alternating voltage when the electric motor is driven.

The inverter is also known as transducer, or DC/AC converter.

### DC/DC Converter

A DC/DC converter transforms the high direct voltage from the high-voltage battery into a corresponding low charge voltage for charging the 12 V onboard supply battery. DC/AC converters and DC/DC converters are often combined with other electronic components of the high-voltage system in a power electronics module.

### Charging Source/Charging Contact

A charger that is incorporated in the high-voltage system in the vehicle is also called an AC/DC converter. It converts the alternating current supplied via the charging contact into a direct current since only direct current can be stored in batteries.

Charging with direct voltage (DC charging) is also possible. However, the supply of a direct voltage via a public electricity system is complex.

### High-Voltage System

The high-voltage system is separate from the 12 V vehicle electrical system with one exception. The DC/DC converter is the only component that is connected to both electrical systems.

All high-voltage lines are colored orange and are highly resistant to damage. They are reinforced by an additional woven sleeve that is also orange in color. Electrical connectors for the high-voltage system are reverse polarity protected and color coded. Electrical components outside the high-voltage system (e.g. lights, steering, vacuum pump for brake servo and power outlets) are powered by the conventional 12 V vehicle electrical system.

# Basics of Electromobility

---

## Other High-Voltage Units

In addition to the pure drive components, other components can be supplied with high voltage in high voltage vehicles. Examples are the air conditioning system and/or the heating and ventilation system. In high-voltage vehicles that operate without combustion engine, components that are driven mechanically by the combustion engine using a belt drive need to be operated electrically. This does not necessarily have to be done with high voltage. Instead, the units can also be configured as 12 V components that are supplied via the 12 V onboard supply (e.g. power steering pump, brake servo). Units will be configured as high-voltage components only if a high output is required, like with the air conditioner compressor. All high-voltage units are marked with a warning sticker.

## Transmission

Pure electric vehicles (BEV) do not require the traditional transmission with several speeds. The polarity of the electric motor is simply reversed when you want to reverse the vehicle. This means that the direction of rotation of the electric motor changes. This is done with a gear selector lever, which simply has the positions "Neutral", "Forward" and "Reverse". The speed can be regulated infinitely with the accelerator pedal. Full hybrid vehicles (HEV) and plug-in hybrid vehicles (PHEV) still have a conventional transmission. As a rule, these are not manual transmissions, but automatic or dual clutch transmissions.

## Brake System

An electric vehicle has two independent brake systems. One system is the traditional mechanical/ hydraulic brake system. The second brake system is formed by the electric drive motor as an "engine brake". The advantage of this "engine brake" compared with the combustion engine is that the energy released by the electric motor/generator during braking and deceleration is recovered and fed into the high-voltage battery. This regenerative braking contributes to the high efficiency of the electric vehicles in particular in city traffic. In addition, the wear of the vehicle brakes is reduced by the regenerative braking system.

# Basics of Electromobility

## Drive Train Configurations

An electric vehicle is driven by at least one electric drive motor. It can be configured as a four-wheel drive vehicle or with one drive axle. Other hybrid variations are also possible.

The two main concepts are described in this section.

1. Drive with in-wheel motors
2. Drive with just one electric drive motor in the central drive train

### Drive with In-Wheel Motors

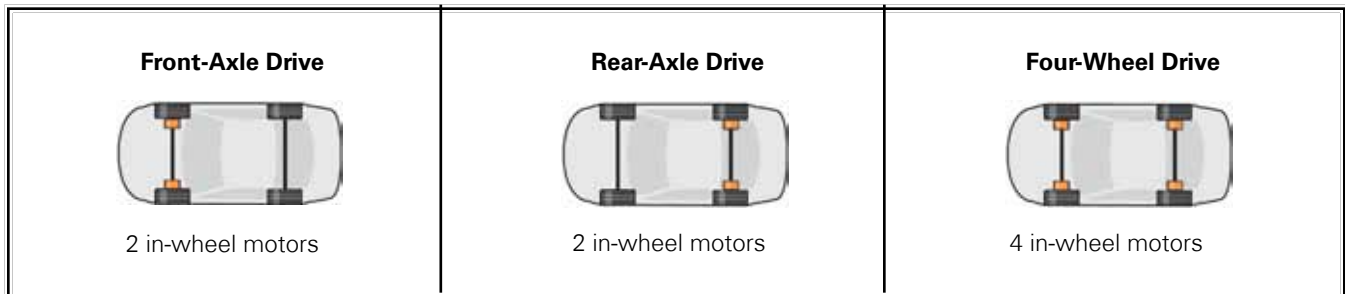

#### Design

The wheels are connected directly to the in-wheel motors. The in-wheel concept is used for electric scooters, electric bicycles and electrically driven wheel chairs.

#### Advantages

- Four-wheel drive is technically possible
- Output axles of the in-wheel motors are directly on the wheel
- High efficiency because there are hardly any mechanical losses
- Possibility of regenerative braking

#### Features

- No drive shafts are required
- No differential transmission required

#### Disadvantages

- Unsprung masses in the wheel are greater than wheels on a conventional vehicle
- High mass of driven components (inertia and torque of whole vehicle affected)
- New vehicle design required
- Control is complex, both electric motors must run synchronously
- Combination with a hydraulic friction brake is still currently necessary
- Limited space on the wheel

# Basics of Electromobility

## Drive with Electric Motor in Central Drive Train

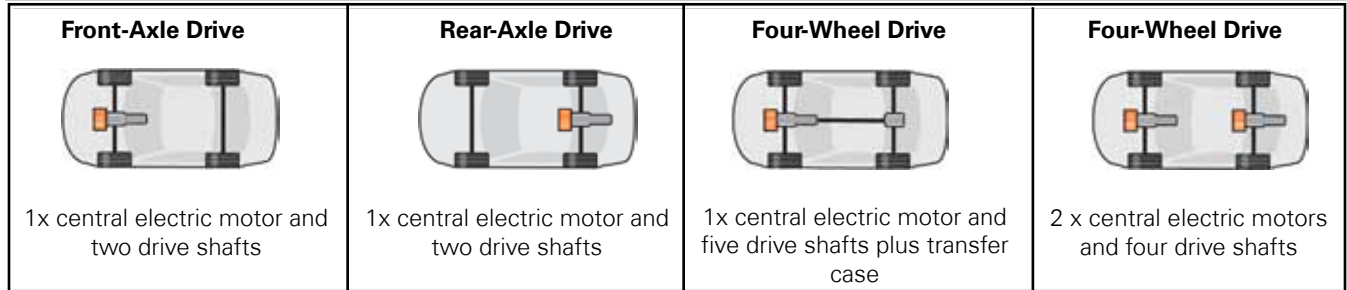

### Design

The electric motor/generator drives a transmission, the drive shafts and the wheels.

In a pure electrically powered vehicle, a reduction transmission is used. Four-wheel drive can be added with a drive shaft from the front axle. Another possibility is to use a second electric motor.

### Advantages

- Single-axle drive simple to design
- Four-wheel drive is possible
- Combination as hybrid drive (HEV / PHEV / RXHEV) possible
- Integration in existing vehicle concept is possible

### Features

- Two drive shafts on each driven axle
- A differential on each driven axle
- Driveshaft required

### Disadvantages

- Output shaft of central electric motor/generator is not on the drive axles.
- Differential required
- Reduction gear required



Volkswagen is currently only using drives with a central electric motor/generator as the only drive or in combination with combustion engines as hybrid drives. In-wheel motors are currently not used.

# Vehicle Concepts

## Drive Combinations

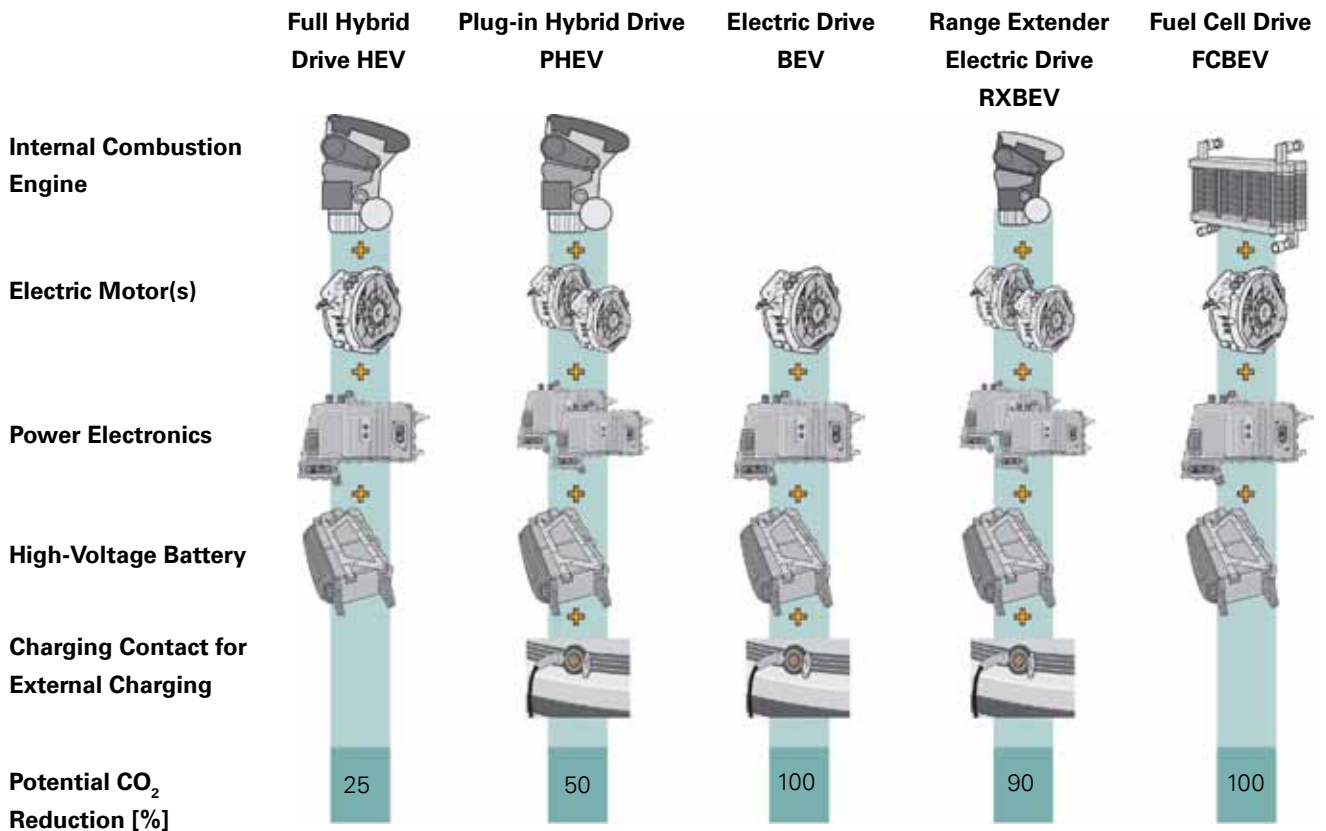

s499\_259

There are several different hybrid and electric vehicle concepts. Some are currently on the market, others exist as prototypes.

All concepts have a certain number of common high-voltage components. The components are in all high voltage vehicles in different forms.



## Touareg with Full Hybrid Drive (HEV)



s499\_019

In full hybrids, the vehicle has a conventional internal combustion engine and an electric motor/generator that functions as an alternator, drive unit and starter motor.

The individual operating modes depend on factors like the charge state of the high-voltage battery, accelerator pedal position and brake pedal values. Both the internal-combustion engine and the electric motor/generator transfer their power through a clutch and a transmission to the drive axles.

In addition to the high-voltage system, the Touareg HEV also has a 12 V onboard supply with its own 12 V onboard supply battery.

In this design, the interior is heated with the coolant from the combustion engine.

## Design

### Power Units and High-Voltage Components

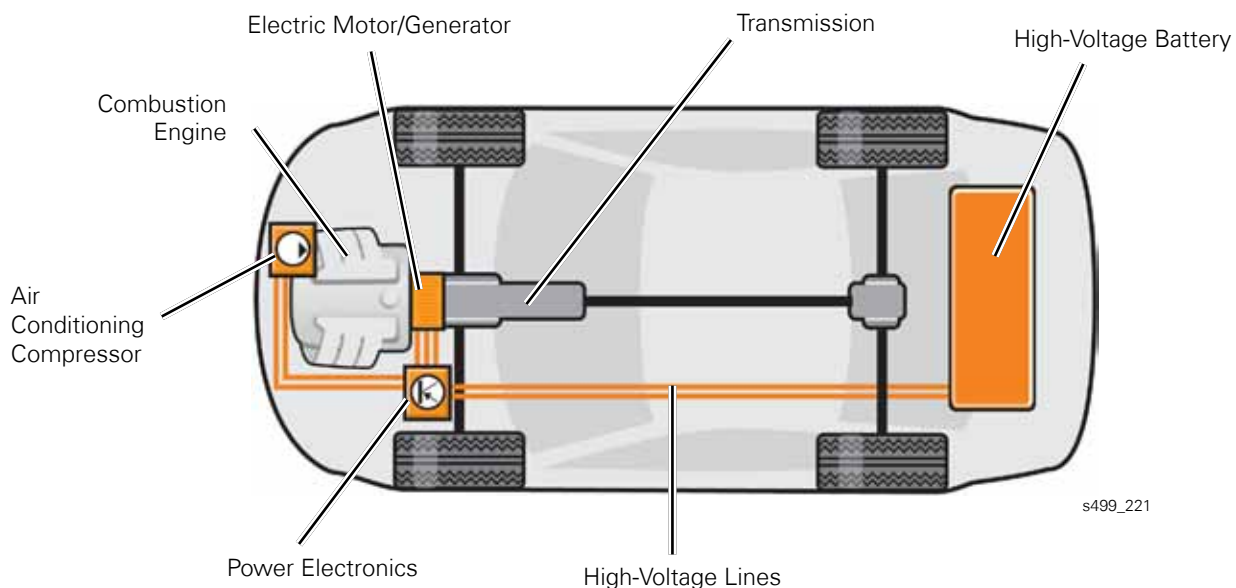

s499\_221

# Vehicle Concepts

## HEV Operating Modes

### Electric Driving

The combustion engine is deactivated. The electric motor/generator drives the vehicle. In a hybrid, all functions that are normally driven by the running combustion engine are performed by different high voltage and 12 V units.

### Combustion Engine Off

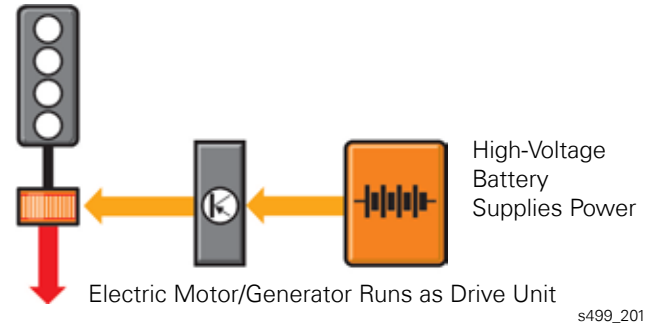

### Combustion Engine Operation

The combustion engine drives the vehicle. The high voltage battery is charged (depending on the charge status).

### Combustion Engine Running

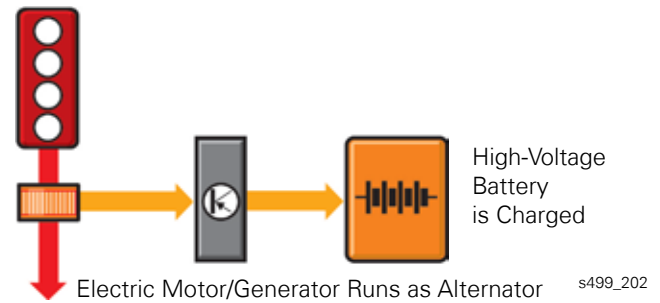

### E-Boost

The electric drive motor supports the combustion engine when there is a high load requirement. The outputs of the combustion engine and electric motor/generator are combined.

### Combustion Engine Running

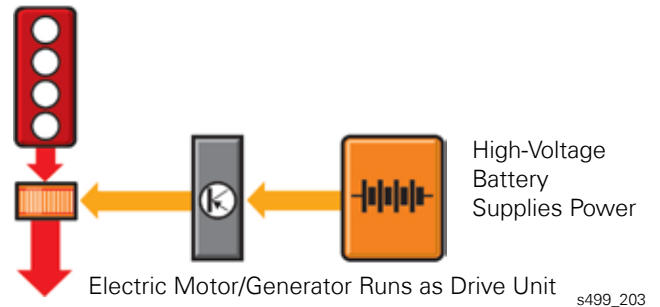

### Regenerative Braking

The combustion engine is normally turned off. The braking energy is converted into electrical energy by the electric motor/generator (which is functioning as an alternator) and stored in the high-voltage battery.

### Combustion Engine Off

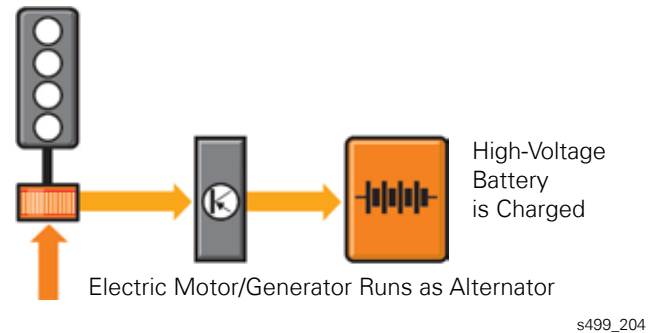

## The Golf 6 TwinDrive (PHEV)



s499\_253

Compared to the full hybrid drive, the TwinDrive has two electric motors. One of the electric motors is used exclusively as an alternator or starter and the other electric motor is used as an electric motor and alternator. The two electric motors and the combustion engine are connected to each other via clutches.

The operating mode determines the interaction of the two electric motors and the combustion engine.

The high-voltage battery in the TwinDrive can also be charged via an external 230 V connection. It can even feed electricity into the 230 V connection via the charging cable if the house connection to the 230 V connection is correctly configured.

The vehicle also has a 12 V onboard supply with its own 12 V onboard supply battery.

## Design

### Power Units and High-Voltage Components

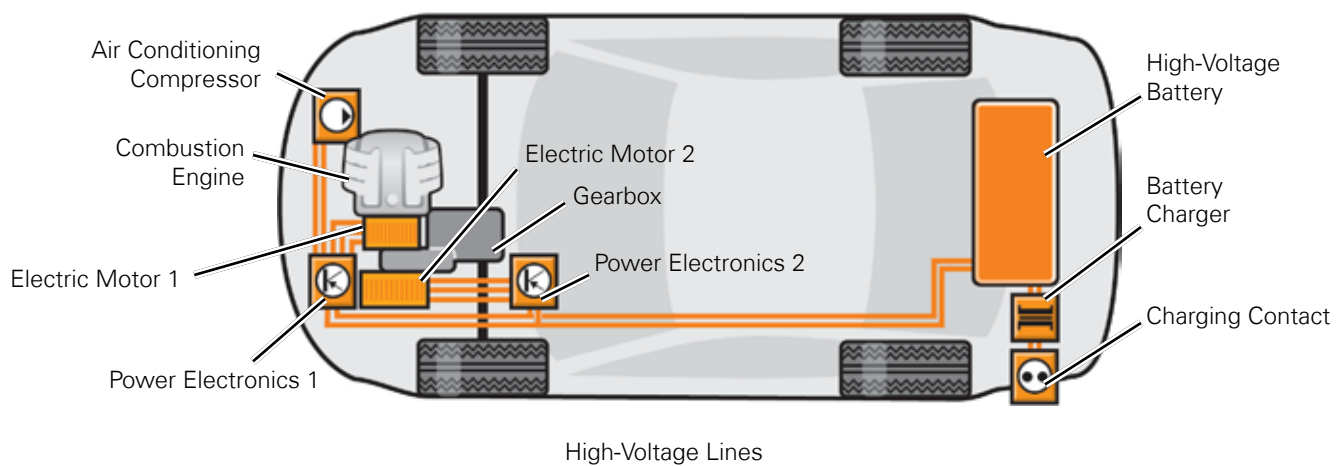

s499\_222

# Vehicle Concepts

## PHEV Operating Modes

### Electric Driving

The combustion engine is deactivated. The vehicle is driven by Electric Motor 1. The high-voltage battery supplies the energy via Power Electronics 1.

### Combustion Engine Off

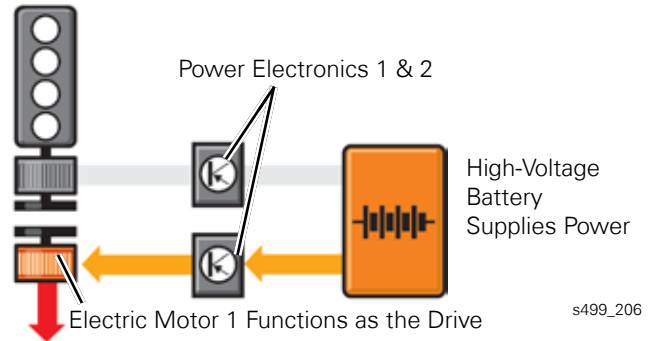

### Series Driving

Electric Motor 2 starts the combustion engine. Then Electric Motor 2 runs as an alternator and feeds the high-voltage battery. This motor supplies energy so Electric Motor 1 can drive the vehicle electrically. This operating mode does not happen frequently.

### Combustion Engine Running

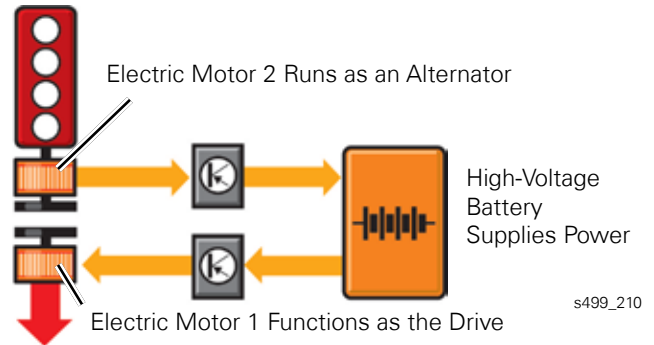

### Boost

The combustion engine and electric motors accelerate the vehicle. This function depends on the charge state of the high-voltage battery.

### Combustion Engine Running

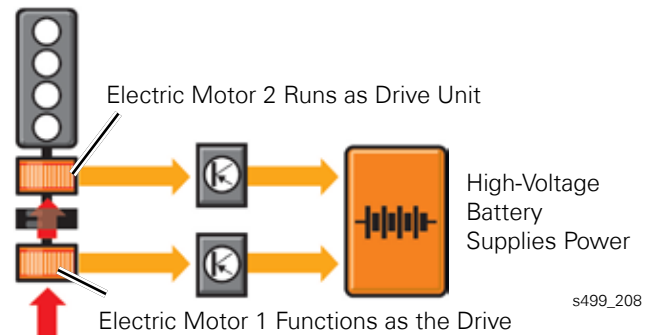

### Driving with Combustion Engine

If the high-voltage battery is completely discharged, electric driving is not possible. The combustion engine drives the vehicle while charging the high voltage battery through Electric Motor 2.

### Combustion Engine Running

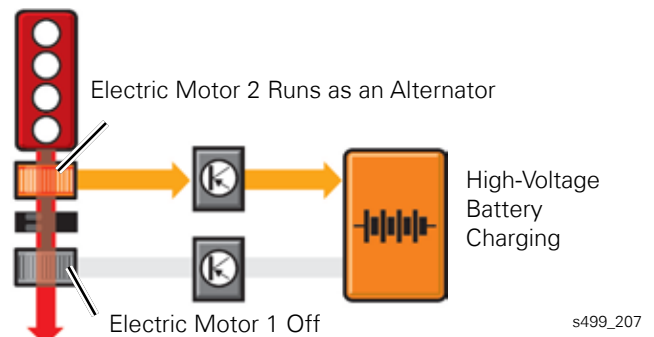

# Vehicle Concepts

## Combustion Engine Running

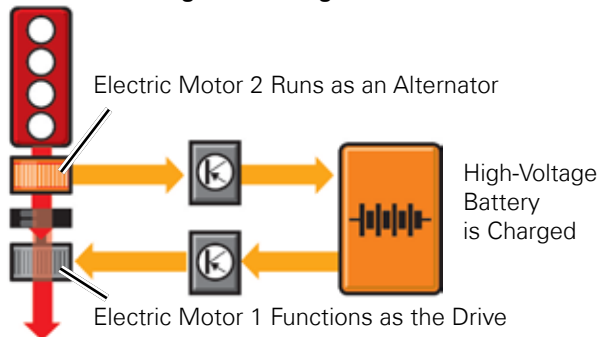

s499\_211

## Coupled Driving and Charging

The route planned by the driver may require that the combustion engine drives the vehicle and, at the same time, the extra power is used to charge the high-voltage battery.

## Combustion Engine Off

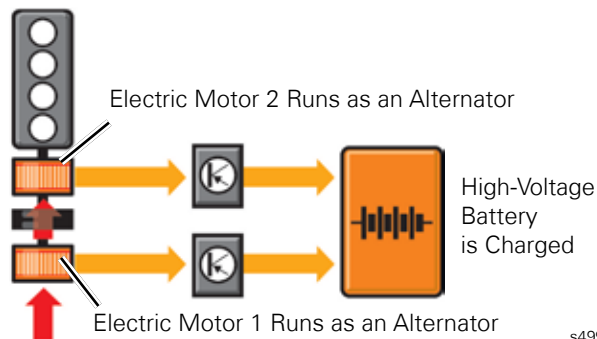

s499\_209

## Regenerative Braking

Both electric motors can be used for regenerative braking when the clutch is engaged. The energy from the deceleration of the vehicle is converted into a direct voltage by the two power electronics units and immediately stored in the high-voltage battery.

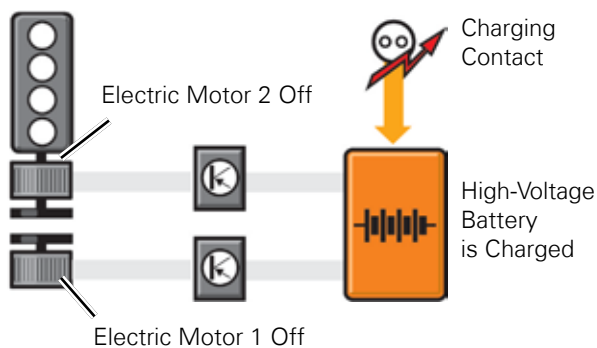

s499\_226

## External Charging

The high-voltage system is in stand-by mode during external charging. The electric motors and power electronics are deactivated. The charging cable is connected to the vehicle via the charging contact. When a source of electricity for charging the high-voltage battery is recognized by the control module, two charge protection relays are closed.

The charging process is stopped when the battery capacity has been reached. Electrical components that are activated during the charging process are powered by the external charging source.

# Vehicle Concepts

## The Golf Blue-E-Motion (BEV)

### Example of 2011 Test Fleet

The blue-e-motion is a purely electric vehicle without a combustion engine. The battery can only be charged using regenerative braking or an external power source.

In addition to the high-voltage system, the vehicle has a 12 V onboard supply with its own 12 V onboard supply battery. The electric motor/generator delivering 85kW transfers the power to the drive wheels using a transmission and differential.



s499\_253

The driver operates the vehicle exactly the same way as a vehicle with an automatic transmission. When the selector lever is in the "B" position (regenerative braking), the system supplies the maximum possible regenerative braking when the accelerator pedal is released. The vehicle can come to a complete stop using this function - without using the brake pedal. The electric drive motor does not generate enough heat for the interior of the vehicle. Because of this, the blue-e-motion has a high-voltage heating system.

## Design

### Drive Units and High-Voltage Components

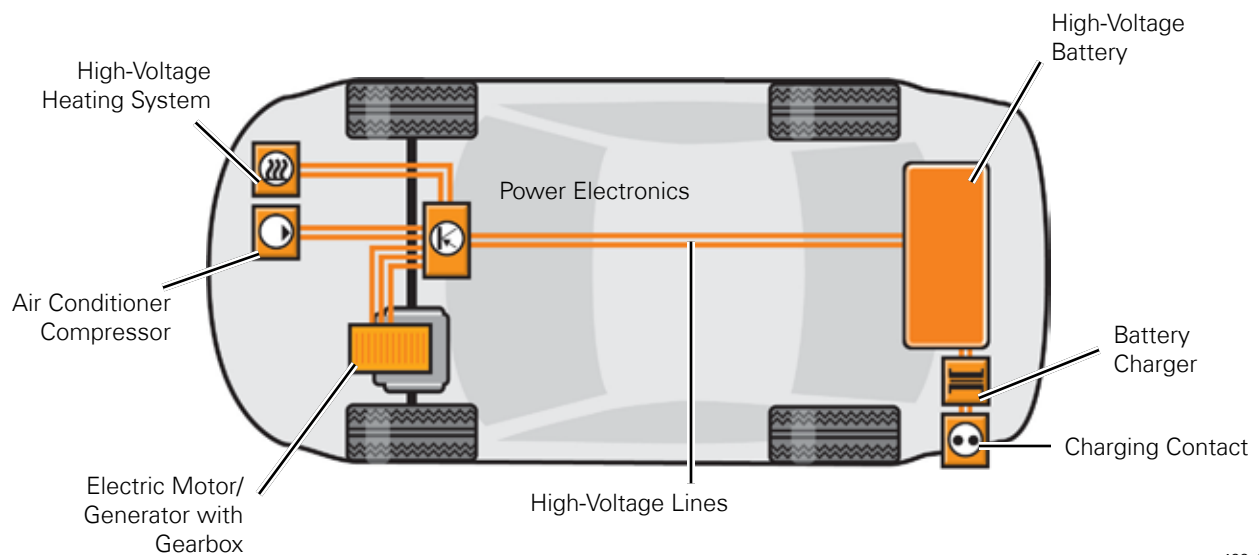

s499\_224

## BEV Operating Modes

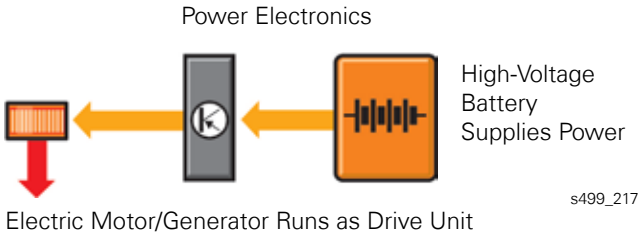

### Electric Driving

Electrical driving: the high-voltage battery supplies energy to the power electronics. The power electronics convert the direct voltage into an alternating voltage to drive the electric motor.

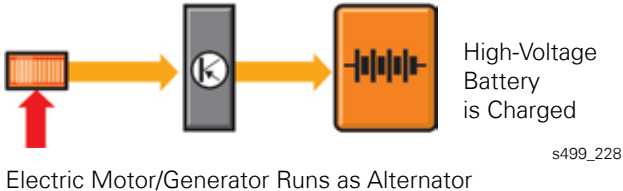

### Regenerative Braking

If the electric vehicle “coasts” (the vehicle moves without drive torque from the electric motor), part of the kinetic energy is fed into the high-voltage battery by the electric motor which functions as an alternator.

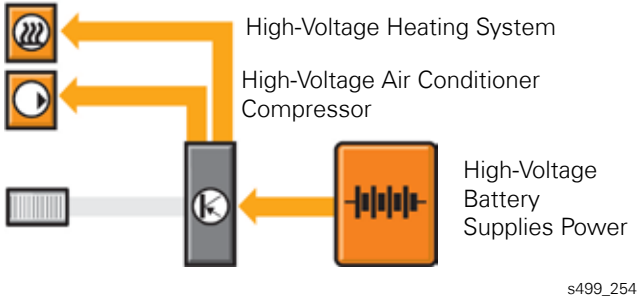

### Climate Control while Vehicle is Stationary

If the electric vehicle is standing in a traffic jam, no output is required from the electric motor/generator. The comfort requirements of the occupants are met with a high-voltage heating system and a high-voltage air conditioner compressor.

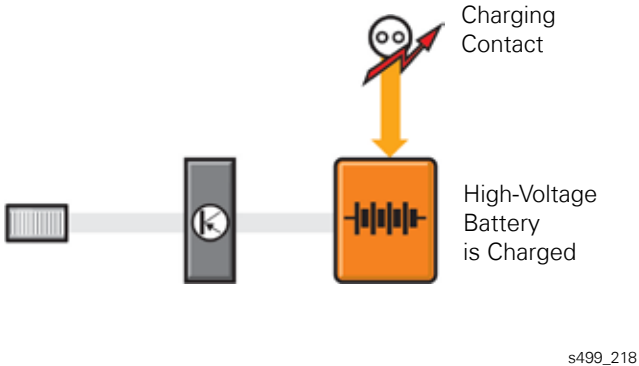

### External Charging

The high-voltage battery is charged via the charging contact on the vehicle. When the external charging source is connected, the vehicle is charged automatically up to the previously set value. The process is ended automatically. If electrical components are used during the charging process, they are supported by the charging voltage.

# Vehicle Concepts

## The Audi A1 e-tron (RXBEV)

(concept vehicle)

This is an example of a range extender (RXBEV). It is driven by a combustion engine and two electric motors. Unlike the previously described systems, the combustion engine does not have a mechanical connection to the drive axles. The vehicle has an electric-only drive.

The combustion engine only drives Electric Motor 1, which functions as a generator and charges the high voltage battery while the vehicle is driven. The combustion engine runs at its optimum map with high output and low consumption. This setup allows the vehicle range to be extended.



s499\_256

The high-voltage battery is mainly charged externally. The mobile recharging possibility with the combustion engine and Electric Motor 1 working as an alternator can be seen as a back-up generator. In addition to the high-voltage system, the vehicle has a 12 V onboard supply with its own 12 V onboard supply battery.

## Design

### Drive Units and High-Voltage Components

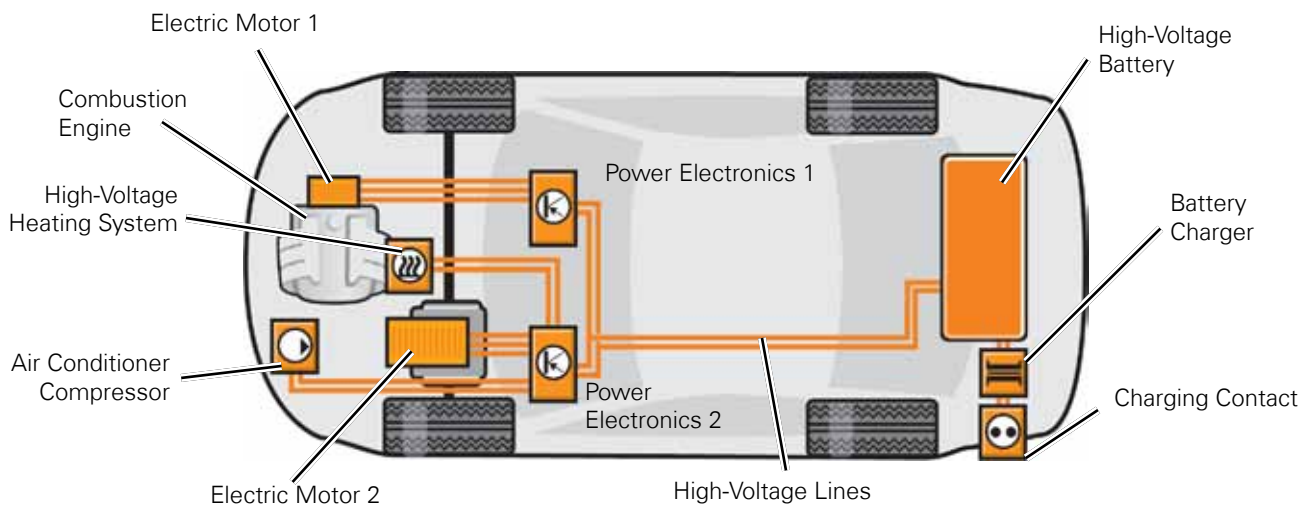

s499\_223



# Vehicle Concepts

## RXBEV Operating Modes

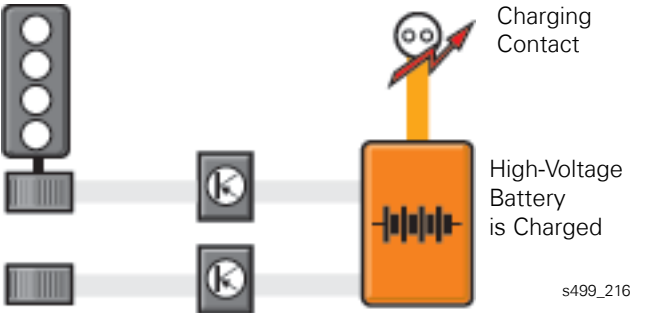
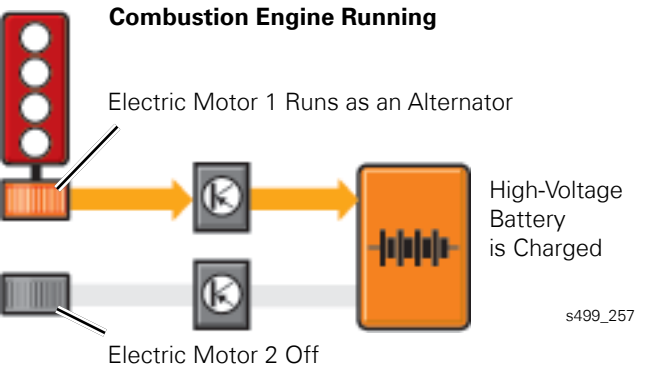
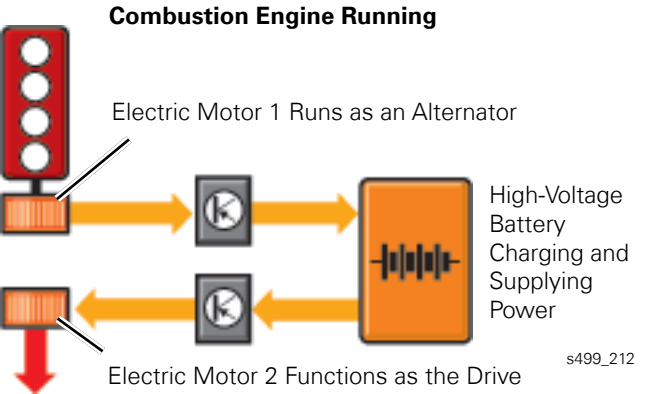
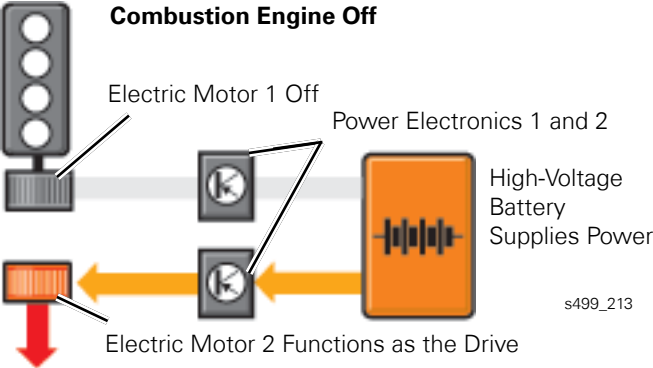

### Electric Driving

If the high-voltage battery is charged, the vehicle is driven electrically with Electric Motor 2. Convenience components (high-voltage heating system and high voltage air conditioner compressor) and the 12-volt onboard supply battery are powered through Power Electronics 2.

### Electric Driving and Charging

The high-voltage battery is discharged. The combustion engine starts to continue the journey. It drives Electric Motor 1 and charges the high-voltage battery. Electric Motor 2 is the only source of propulsion and the only means of regenerative braking.

### Charging Battery when Vehicle is Stationary

The combustion engine can charge the high-voltage battery using Electric Motor 1 while the vehicle is stationary.

### External Charging

The high-voltage system and the complete drive system are deactivated. The high-voltage battery is charged through the charging connection on the vehicle, the high voltage charger and the two charge protection relays. The charging process is automatically monitored and ended by the system.

# Vehicle Concepts

## The Tiguan HyMotion (FCBEV)

The HyMotion features a fuel cell drive. The vehicle is fueled with hydrogen and obtains the electrical energy for the electric motor from a fuel cell module.

In this module, the hydrogen is turned into water to produce electrical energy. Depending on the operating mode, the charging voltage for the high voltage battery is used for the drive.

There is no combustion engine.

The high-voltage battery can only be charged externally by workshops with a special battery charger. In addition to the high-voltage system, the vehicle also has a 12 V onboard supply with its own 12 V onboard supply battery.



s499\_258

## Design

### Drive Units and High-Voltage Components

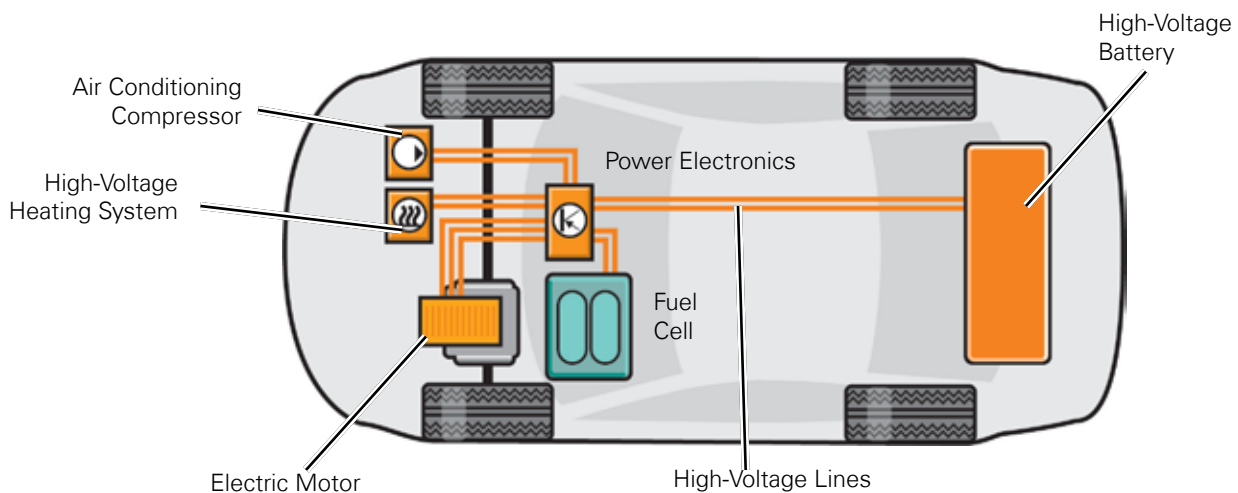

s499\_225

## FCBEV Operating Modes

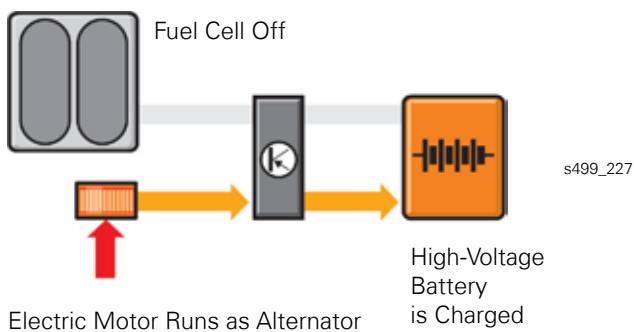
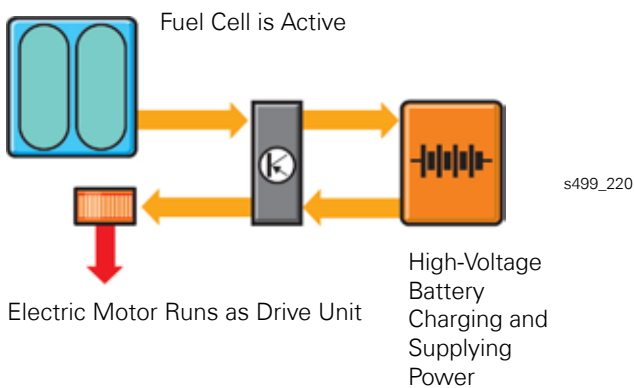
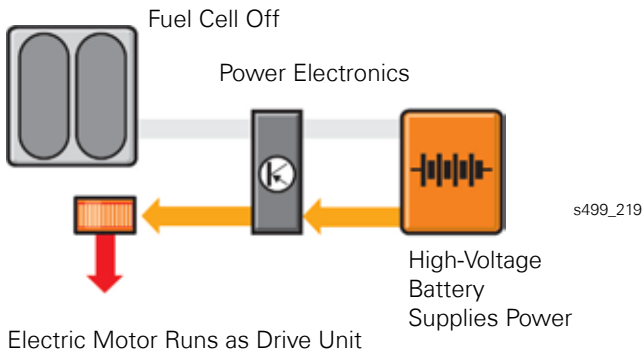

### Electric Driving

If the high-voltage battery has been charged, the vehicle can be driven electrically. In this case, the fuel cell does not supply any energy and does not consume any hydrogen.

### Electric Driving and Charging

The fuel cell is activated when the high-voltage battery requires its power. The electrical energy for driving and for charging the high-voltage battery is produced from the hydrogen with the aid of oxygen from the air.

### Regenerative Braking

The electric motor exclusively takes care of regenerative braking. During over-run, the electric motor functions as an alternator. It charges the high voltage battery via the power electronics.

## Hydrogen for the Fuel Cell

The hydrogen tank can be filled at special filling stations. The fueling procedure is identical to that for natural gas. The hydrogen is pumped into pressurized tanks under the vehicle at pressures up to 700 bar (10,153 psi).

Due to the physical properties of hydrogen, 80 litres weigh about 6.44kg (14 lbs). The hydrogen reaches the fuel cell through pressure reducers. At an operating pressure of 3 bar, it supplies a direct voltage of 250V to 450V.

# High-Voltage Safety

---

## What Does High Voltage Mean?

Vehicles with high-voltage systems (HV) have components that work with voltages above 60V direct voltage or 25V alternating voltage. Some of the components in these vehicles require a high level of electrical power. The high-voltage systems in vehicles work with direct voltages of up to 650V and very high peak currents.

## What Dangers are Involved in Working with High-Voltage Systems?

All muscle reactions, like moving your arm, your heart beat or eyes winking, are controlled by electrical stimulation. These electrical stimulations are conducted inside the body through nerve pathways in a similar way to currents in electrical circuits.

If you touch live high-voltage components, the current can flow through your body. Even with direct currents above approximately 30 mA, temporary heart pulse disturbance can occur depending on how long the current flows through the body. At even higher currents in the body, serious internal burns occur and in some cases ventricular fibrillation can result.

If the two poles of an electrical system are short-circuited, there is a risk of arcing. This can cause serious external burns on the human body and electro-ophthalmia of the eyes.

## Safety Precautions

- Eliminate the risk of contact with live high-voltage components.
- Only specially qualified personnel may perform work on the high-voltage system.
- In addition to the color coding and warnings given on labels on the components, there are technical safety measures.
- The safety equipment used is vehicle-specific.
- In this section, basic safety aspects are explained without looking at the special requirements of every vehicle.

Please refer to the repair information for specific vehicle information.

# High-Voltage Safety

## The Electrical Isolation of the High-Voltage System and 12 V Onboard Supply

### Purpose

The isolation of the high-voltage system and 12 V onboard supply is designed to prevent unintentional short-circuits with the vehicle ground. This isolation of the high-voltage system from the body ground is also called electrical isolation.

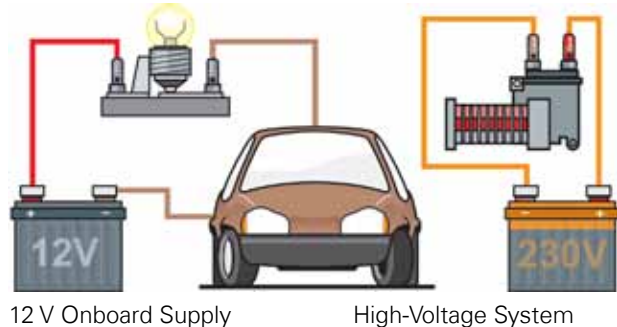

s499\_242

### How it Works

To achieve this isolation, the high-voltage system has its own equipotential bonding. The high-voltage system and the 12 V onboard supply are electrically isolated from each other so that there can be no accidental short-circuit and a flow of current to the body ground.

While the circuit in the 12 V onboard supply normally runs via the vehicle ground, all high-voltage components have two wires that form the electrical circuit. There is no connection to the body ground.

### High-Voltage Isolation with Ignition "off"



s499\_260

s499\_261

### Task

The simplest way to deactivate the high-voltage system and disconnect the high-voltage system from the high-voltage battery is to turn the ignition key to the "Off" position.

Depending on the vehicle equipment, this can also be done with an "Engine Off" button (e.g. with Keyless Entry).

### How it Works

The ignition lock or the "Engine Off" button are used as switches to interrupt the electric circuit of the protective relay of the high-voltage system. This opens the protective relays and the high-voltage battery is disconnected from the high-voltage system. The high-voltage system is de-energized after a short time. The high-voltage battery itself and the high-voltage lines up to the protective relays are still energized.

# High-Voltage Safety

## The Protective Relays in the High-Voltage System (High-Voltage Contactor)

### Purpose

The high-voltage battery is connected to the high-voltage system. Each high-voltage connection has its own protective relay that can interrupt the circuit. The protective relays have the task of connecting the high voltage system in the vehicle (contactor closed) or disconnecting it (contactor open).

### How it Works

The protective relays are only switched by the high-voltage system. If the contactors are de-energized, they open and the high-voltage battery is disconnected from the high-voltage system in the rest of the vehicle.

The command to open can be triggered by different situations. If you turn off the vehicle and remove the ignition key, this also opens the contactors and activates the other safety systems.

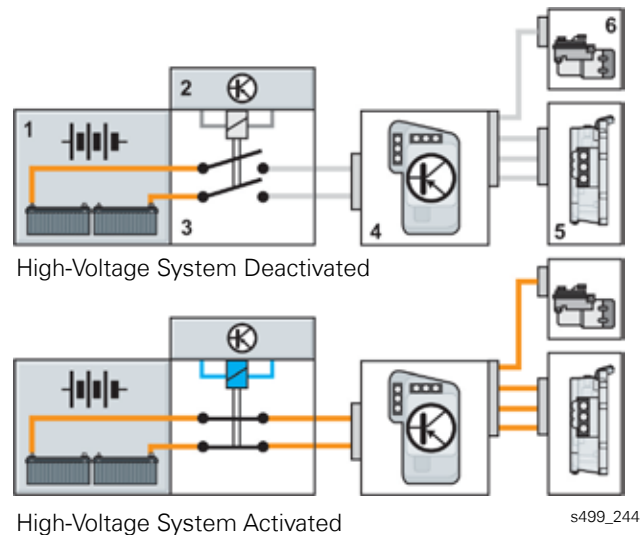

1. High-voltage battery
2. Battery management
3. Protective relay (contactor)
4. Power electronics
5. Electric motor/generator
6. Air conditioner compressor



Work on the high-voltage system may only be performed by qualified Volkswagen high-voltage technicians. The instructions in the repair information must be strictly followed for the proper and safe use of the special high-voltage tools.

## The Pilot Line

### Purpose

The pilot line is a completely independent safety system that determines if all high-voltage components are correctly connected to the high-voltage system. The pilot line is a low-voltage system.

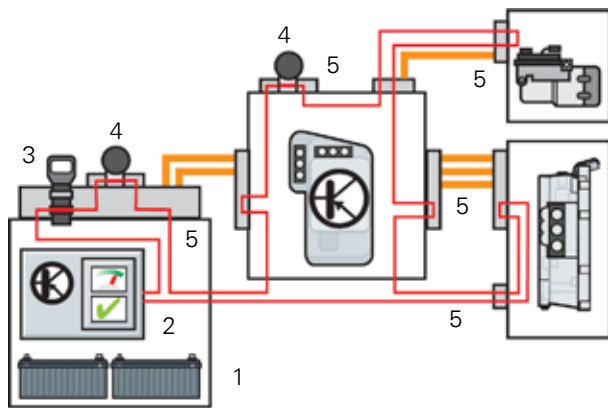

Continuous Pilot Line

s499\_246

1. High-voltage battery
2. Battery manager
3. Maintenance connector
4. Pilot line connectors
5. Connections for high-voltage components

### Design

The pilot line connects all high-voltage components. The system checks whether the high-voltage connections of the components in the pilot line are correctly connected.

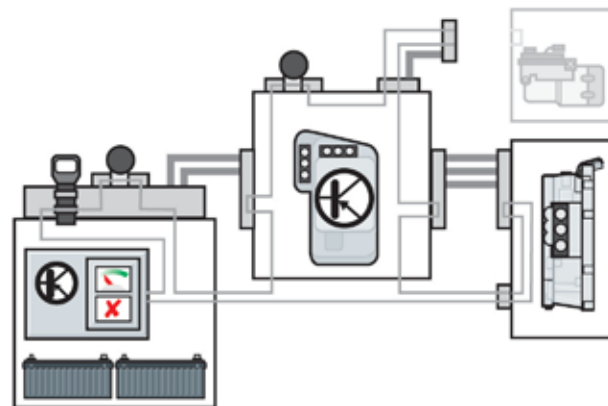

Pilot Line Interrupted

s499\_245

### How it Works

The pilot line circuit is interrupted as soon as a high voltage contact on a high-voltage component is disconnected. This happens whenever a cable is disconnected, the maintenance connector is removed or when a high-voltage component is replaced.

As soon as the high voltage system detects that the pilot line is interrupted at any point, the protective relays are opened and the high-voltage battery is isolated from the high voltage system.

# High-Voltage Safety

## Maintenance Safety

### Purpose

The high-voltage system normally has a maintenance connector near to the high-voltage battery as an additional safety feature for de-energizing the high-voltage system. If the maintenance connector is unlocked and removed, the pilot line is disconnected. This opens the contactors, causing the high voltage battery to be disconnected from the high-voltage system. It also separates the two halves of the battery. The maintenance connector may also contain the main fuse for the high voltage battery (e.g. 2011 Touareg Hybrid).

### Set-up Using 2011 Touareg Hybrid as an Example

The maintenance connector is under an orange colored cover near to the high-voltage battery in the electronics box. It is an electrical bridge between the battery modules of the high-voltage battery and, at the same time, part of the pilot line. The maintenance connector must be unlocked before it can be pulled out of its fitting. The appearance of the connector may vary and depends on the vehicle type.

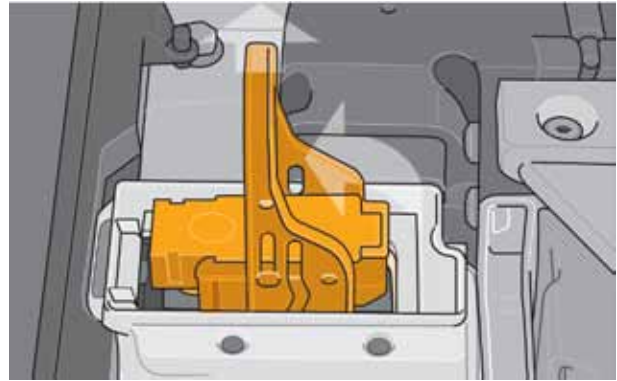

s499\_247

### How it Works

Unlocking the maintenance connector interrupts the pilot line and deactivates the high-voltage system. The protective relays (contactors) open and disconnect the high-voltage system from the high-voltage battery. Disconnecting the maintenance connector electrically isolates the battery modules of the high-voltage battery from each other. Only the actual battery modules are now live with a reduced voltage.



Make sure you follow the three basic rules of high-voltage safety:

1. De-energize the high-voltage system.
2. Secure the vehicle against reactivation.
3. Check/determine whether the high-voltage system is de-energized.

This procedure is known as certified de-energization and may only be performed by a high-voltage technician.



## Crash Safety

### Purpose

Deactivation of the high-voltage system and the de-energization of the high-voltage system is important for occupant protection in accidents, the safety of rescue personnel and safety of accident vehicles that have been brought in for repair. As a result, the high-voltage safety is linked to the crash detection system via the airbag control module.

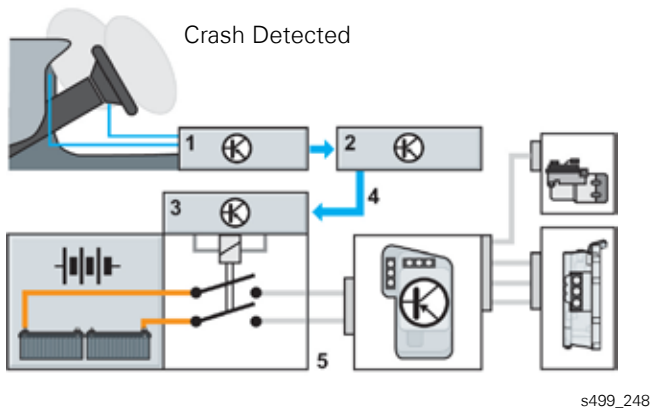

1. Airbag control module
2. Data bus diagnostic interface
3. Control unit for battery regulation
4. CAN message
5. High-voltage system

### How it Works

As soon as the airbag control module detects an accident and deploys the belt tensioner or airbags, the battery regulation control module is instructed via the CAN data bus to open the protective relays.

If just the belt tensioners are deployed (single-stage crash deployment), it is possible to close the contactor by turning the ignition on and off again. The belt tensioners and airbags are deployed in the second crash stage. The contactors can then be closed again only with the VAS tester.



Always refer to the respective guidelines for rescue services for information on the different ways to deactivate the high-voltage systems in crashed vehicles.

# High-Voltage Safety

## Safety During External Charging

If the vehicle has a charging contact for external charging, protective relays are located in the charging circuit of the high-voltage system. They only connect the high-voltage battery to the charging contacts if the system detects that the charging contact has been connected and a voltage is present. The charging procedure can be performed safely in rain or if the contacts have been exposed to moisture.

## Monitoring the Insulation Resistance

The battery regulation control module transmits a test voltage while the high-voltage vehicle is in use. The test voltage is 500V and has a low current which is not dangerous for humans.

If all high-voltage components and wires are correctly insulated and shielded, the control module calculates and compares the previously set total resistance of the high-voltage system.

If the insulation of a wire is damaged externally, for example, by a vermin bite, the insulation resistance changes. The control module detects an insulation fault due to this change in resistance.

Depending on the severity of the fault, various messages can appear in the vehicle instrument cluster.



s499\_277



Always replace damaged high-voltage lines. The insulation cannot be repaired because of the insulation resistance monitoring system. Slight deviations in the resistance, such as damp weather with salt ingress, can cause an insulation fault.

# High-Voltage Safety

## Warning Stickers

During work with high-voltage vehicles, different warnings draw attention to the special characteristics of the high voltage technology.

### Warning Notices Related to High Voltages



s499\_273

Do not turn on.  
Work on high-voltage system in progress



s499\_269

Caution, hazardous voltage!



s499\_271

Caution!  
Parts carrying high voltages.  
Before starting work, perform certified de-energization of the high voltage system.



s499\_270

Hazardous voltage!  
Electric shock if touched!  
De-activate high-voltage system.



s499\_272

Caution! High-voltage battery  
Incorrect handling can cause injuries.

- High voltage
- Risk of explosion
- Chemical burns and eye injuries

# Service

## Charging Infrastructure for High-Voltage Vehicles

A high-voltage vehicle can consume between 3.3 kW and 10 kW of electrical power while the high-voltage battery is being charged.

Example: In North America the household socket generates 120 V alternating current

Normal household sockets have one phase and supply a maximum current of 16 A at 230 V.

$$\begin{aligned} - P \text{ (single-phase)} &= U \times I \\ &= 120 \text{ V} \times 16 \text{ A [1 VA} \sim 1 \text{ W]} \\ &= 1920 \text{ W} = 1.92 \text{ kW (absolute)} \end{aligned}$$

Due to electrical losses during charging (power dissipation), the value must be corrected to 1.9 kW of the absolute value.

If the high-voltage vehicle can be charged using a socket with three phases, the electrical power that is fed to the high-voltage battery is tripled. As a result, the charging process is shorter.

$$\begin{aligned} - P \text{ (three-phase)} &= 1.9 \text{ kW} \times 3 \\ &= 5.7 \text{ kW} \end{aligned}$$

In future, customers may be able to choose from three charging possibilities for their high-voltage vehicle.

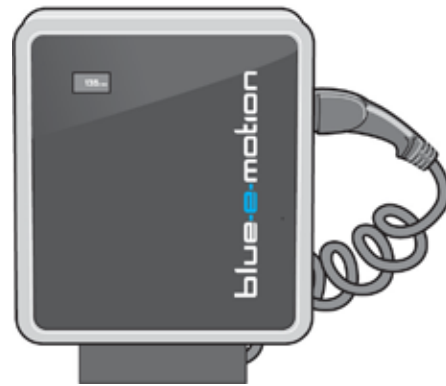

s499\_263

**Charging Unit for Private Households**

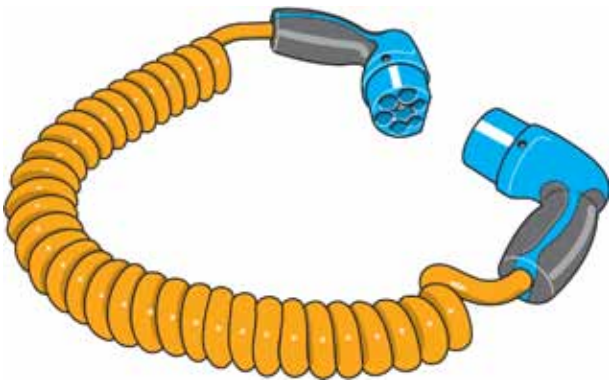

:64

**380V Charging Cable**



s499\_266

**120 V Charging Cable**

A connection check should be performed on site before a customer purchases a high-voltage vehicle that requires an external charging facility. The household electrical system should be able to supply a constant high current for charging the high-voltage battery.

The charging unit is fully set up at the customer's house and connected to the household system. Ideally the unit should be installed as a three-phase charging facility. However, this option depends on the electrical infrastructure that is available at the customer's residence.

In many cities, electricity suppliers offer high-voltage vehicle users the possibility to charge the high-voltage batteries at public charging stations. These stations may vary in power output.

When the high-voltage vehicle user is travelling, the high-voltage battery can be charged using a conventional electrical socket. The current rating can be changed with the selector housing in the center of the cable. This serves as protection so that the electrical system is not overloaded. In addition, the housing contains a residual-current-operated circuit-breaker. This charging method takes longest to charge the high-voltage battery.

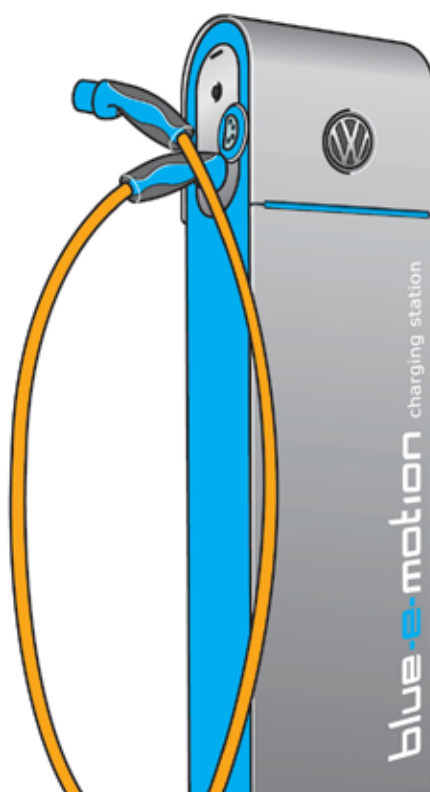

s499\_268

**Public Charging Station**

# Service

## Connector Types

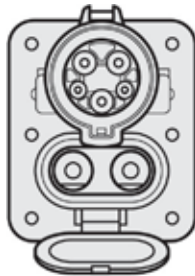

USA

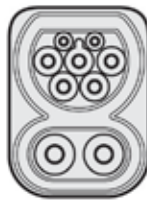

Europe

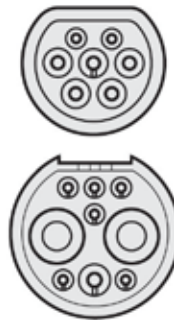

China

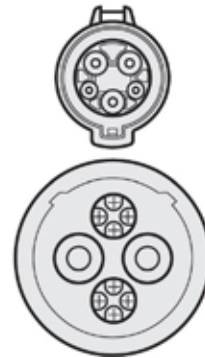

Japan

s499\_265

Across the world a large number of different connector types are used for a wide range of electromobiles like bicycles, light vehicles, scooters and wheelchairs.

During the talks between German car manufacturers, a standard connector type was agreed on.

### The Standard VDE Connector for Charging High Voltage Batteries in Vehicles (VDE = Association for Electrical, Electronic & Information Technologies)

The blue connector is used with the charging unit at the customer's home, the charging cable for public networks and the household cable for charging with any conventional socket.

Charging can be 3-phase using 360 volts or with just one phase using 120 volts.

The connections L1, L2 and L3 are the phases with 120 volts each. The phase shift of  $120^\circ$  results in an effective voltage of 360 V.

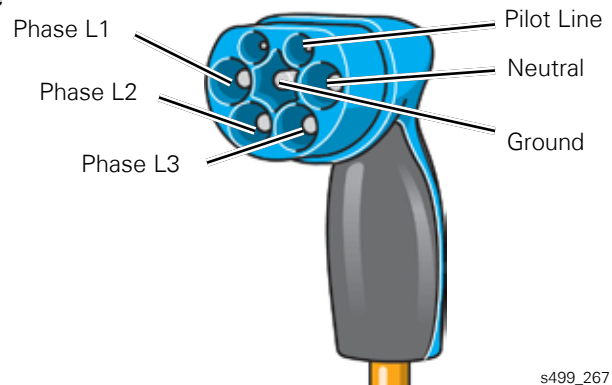

s499\_267

**Standard VDE connector for charging high-voltage batteries**

During the charging process, the vehicle body is grounded via the electrical connection (protective conductor) for electrical safety.

The safety contact of the charging connector activates the charger in the vehicle. The vehicle cannot be driven when the cable is connected.



The connector contacts are scoop-proof (deep socket to prevent connector cocking angle, IPXXB protection class). In addition, a pilot line is used.

This connector and the charging socket on the vehicle allow a charging process to be performed safely in any weather.

## Remote Services

### Using a Mobile Telephone as a Remote Control for the Electric Vehicle

A mobile telephone that has Internet functions similar to a miniature computer is called a smart phone. Thanks to its Internet capability and the networking connection, the phone can be used to operate certain electric vehicle components. An additional application (app) allows the smart phone to be linked to the vehicle. This function is not available on all vehicles.



s499\_262

**Example: German-language remote control display on a mobile telephone**

The user can use the following features of the app:

- Display charge state of high-voltage battery
- Expected range of electric vehicle
- If the high-voltage battery is being charged, the charging duration can be viewed
- Status of vehicle: locked, windows closed, charging connector connected
- Set climate control requirement for interior
- Delayed charging to use cheaper night-time electricity
- Vehicle information like average consumption in kWh/100 km
- Display of convenience consumers in kWh/100 km
- Current vehicle position
- Nearest public charging station
- Plan the remaining electrical range of a hybrid vehicle
  - This function will become useful in the future when city centers, like London, may only be driven through with zero-emissions vehicles (ZEV), i.e. vehicles without direct exhaust gas emissions. For certain hybrid vehicles with an electrical range of about 50 km, route planning is possible via the telephone.

# Service

---

## Think Blue.

“Think Blue.” tasks Volkswagen to dedicate itself to joining individual mobility and sustainable behavior.

An electric vehicle does not produce any direct emissions when driven. The high-voltage battery needs to be charged to move the vehicle. The electrical energy from the external charging source needs to be produced with renewable technology in order to rigorously implement CO<sub>2</sub> reduction measures. The generated energy is used highly efficiently by an electric vehicle.

The goal is the conscious use of resources by humans.

“Think Blue.” goes one step further.

This scheme invites us to think further and shows that ecologically sustained behavior is possible without sacrifices and can also be fun.

“Think Blue.” lives through dialog with customers. The slogan refers to the “Think small” campaign for the Beetle in the sixties. Back then, mobility for everyone was addressed with the Volkswagen Beetle. At the web page [www.volkswagen.com/thinkblue](http://www.volkswagen.com/thinkblue), anyone interested will find information on fuel-saving driving styles, ecological sustainability and conscious use of resources. The creation of awareness starts with small things.

- Does the television standby function always have to be on?
- Maybe it is enough to open a window instead of turning on the air conditioning system?
- Can I save more energy by opening the blinds during the day and turning off the lights?
- Is car-pooling more efficient in terms of CO<sub>2</sub> savings?
- How can I save water at home?

Recognizing savings potential is not the source of sacrifice. The aim is fun while saving: the “fun theory”



The technical scope from the following concepts is combined under the umbrella term “Think Blue”:

- “BlueMotion”
- “BlueMotion Technologies”
- “EcoFuel”
- “Blue TDI”
- “BiFuel”
- “Hybrid”
- “blue-e-motion”
- “Think Blue. Factory.” Low-emissions automobile production

The “blue-e-motion” brand stands for electromobility within the framework of the “Think Blue.” idea. The cornerstones of “Think Blue.” are:

1. Environmentally compatible products and solutions
2. Environmental behavior
3. Environmental commitment

## **Towing an Electric Vehicle**

The drive wheels of an electric vehicle are linked to the electric motor through the differential and the reduction gear. If the drive wheels are rotated, the electric motor will also rotate. If the high-voltage system is activated and ready to drive, the system will recognize the towing procedure as regenerative braking. The high-voltage battery will be charged by the towing procedure.

For this reason, towing electric vehicles on their drive wheels is not permitted. The towing procedure should only be started once the electric vehicle is no longer in running condition. If the high-voltage system is deactivated, the rotation of the electric motor can cause temperatures that damage or destroy components. Furthermore the rotary movement in the electric motor produces an inductivity that acts as a resistance to movement of the vehicle (like a bicycle dynamo).

However, you are allowed to slowly push the electric vehicle out of a dangerous area.

# Service

---

## Special Tools



### **VAS 6558**

The VAS 6558 provides the capability for testing and diagnosing high voltage systems. In addition to the ability to function as a regular voltmeter, it also can function as a MegOhmMeter, providing low-current, high voltage output to test for insulation resistance faults.



**Page intentionally left blank**

# Important Links



[https://www.datarunners.net/vw\\_crc/default.asp?pageid=home](https://www.datarunners.net/vw_crc/default.asp?pageid=home)



[www.vwwebservice.com](http://www.vwwebservice.com)



[www.vwhub.com](http://www.vwhub.com)

# Knowledge Assessment

---

An on-line Knowledge Assessment (exam) is available for this Self-Study Program.

The Knowledge Assessment may or may not be required for Certification.

You can find this Knowledge Assessment at:

**[www.vwwebservice.com](http://www.vwwebservice.com)**

For Assistance, please call:

**Volkswagen Academy**

**Certification Program Headquarters**

**1-877-791-4838**

**(8:00 a.m. to 8:00 p.m. EST)**

Or, E-mail:

**[concierge@volkswagenacademy.com](mailto:concierge@volkswagenacademy.com)**

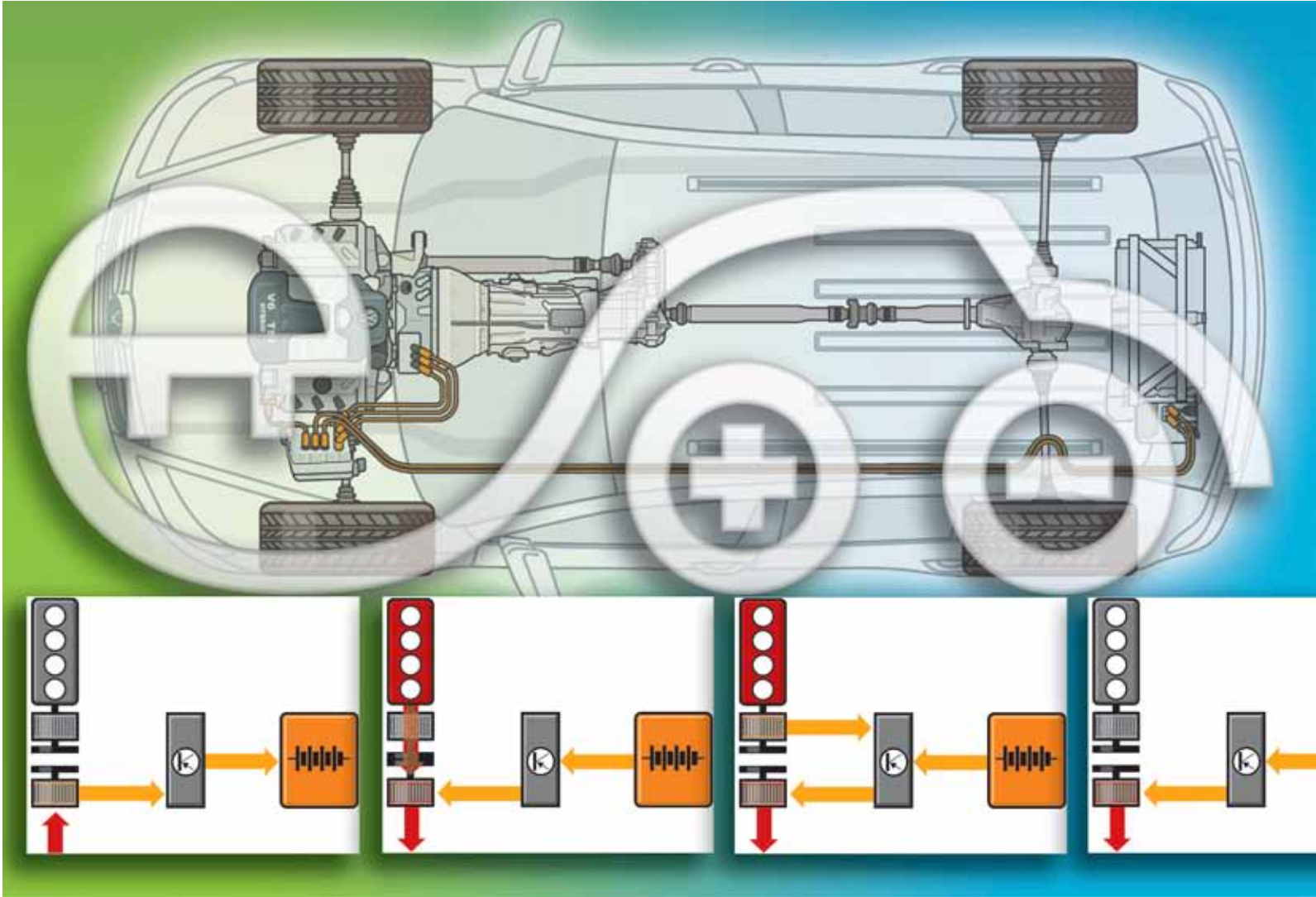

Volkswagen Group of America  
 2200 Ferdinand Porsche Drive  
 Herndon, VA 20171  
 July 2013

