

Service Training



Self Study Program 820133

The 3.0L V6 TDI Engine (Generation 2)

Design and Function



Volkswagen Group of America, Inc.
Volkswagen Academy
Printed in U.S.A.
Printed 2/2013

Course Number 820133

©2013 Volkswagen Group of America, Inc.

All rights reserved. All information contained in this manual is based on the latest information available at the time of printing and is subject to the copyright and other intellectual property rights of Volkswagen Group of America, Inc., its affiliated companies and its licensors. All rights are reserved to make changes at any time without notice. No part of this document may be reproduced, stored in a retrieval system, or transmitted in any form or by any means, electronic, mechanical, photocopying, recording or otherwise, nor may these materials be modified or reposted to other sites without the prior expressed written permission of the publisher.

All requests for permission to copy and redistribute information should be referred to Volkswagen Group of America, Inc.

Always check Technical Bulletins and the latest electronic repair information for information that may supersede any information included in this booklet.

Trademarks: All brand names and product names used in this manual are trade names, service marks, trademarks, or registered trademarks; and are the property of their respective owners.

Contents

Introduction	1
Engine Mechanics	4
Engine Management	36
Knowledge Assessment	41

This Self-Study Program provides information regarding the design and function of new models. This Self-Study Program is not a Repair Manual.

This information will not be updated. For maintenance and repair procedures, always refer to the latest electronic service information.





Page intentionally left blank

Introduction

The first generation of the 3.0L V6 TDI engine entered series production at Volkswagen in 2005.

Over 1.6 million V6 TDI engines have now been built. Now, Volkswagen is introducing the second generation of this engine.

This newly developed engine combines low consumption, low emissions and a high level of power with reduced weight. The development focus was to minimize friction and weight reduction.

An optimized piezo common rail injection system with up to 2,000 bar fuel rail pressure is used.



S495_002

Introduction

The 3.0L V6 180 kW TDI Engine (Generation 2) with Bosch Common Rail Injection System

Technical Features

- Bosch common rail injection system with piezo injectors (2,000 bar injection pressure)
- Oxidizing catalytic converter/diesel particulate filter
- Turbocharger from Honeywell Turbo Technologies (HTT) GT 2260
- Innovative Thermal Management (ITM)
- Chain drive, new chain layout
- Demand-controlled in-tank fuel pump



S495_004

Technical Data

Engine Code	CRCA
Type	V6 Engine with 90° V angle
Displacement	181 in ³ (2,967 cm ³)
Bore	3.3 in (83 mm)
Stroke	3.6 in (91.4 mm)
Valves per Cylinder	4
Compression Ratio	16.8 : 1
Max. Output	241 hp (180 kW) at 3,800 to 4,400 rpm
Max. Torque	406 lb/ft (550 Nm) at 1,750 at 2,750 rpm
Engine Management	Bosch CRS 3.3 common rail injection system
Fuel	Ultra-low sulfur diesel
Exhaust Emissions Standard	EU5

Torque and Output Diagram



S495_055

Crankshaft Drive

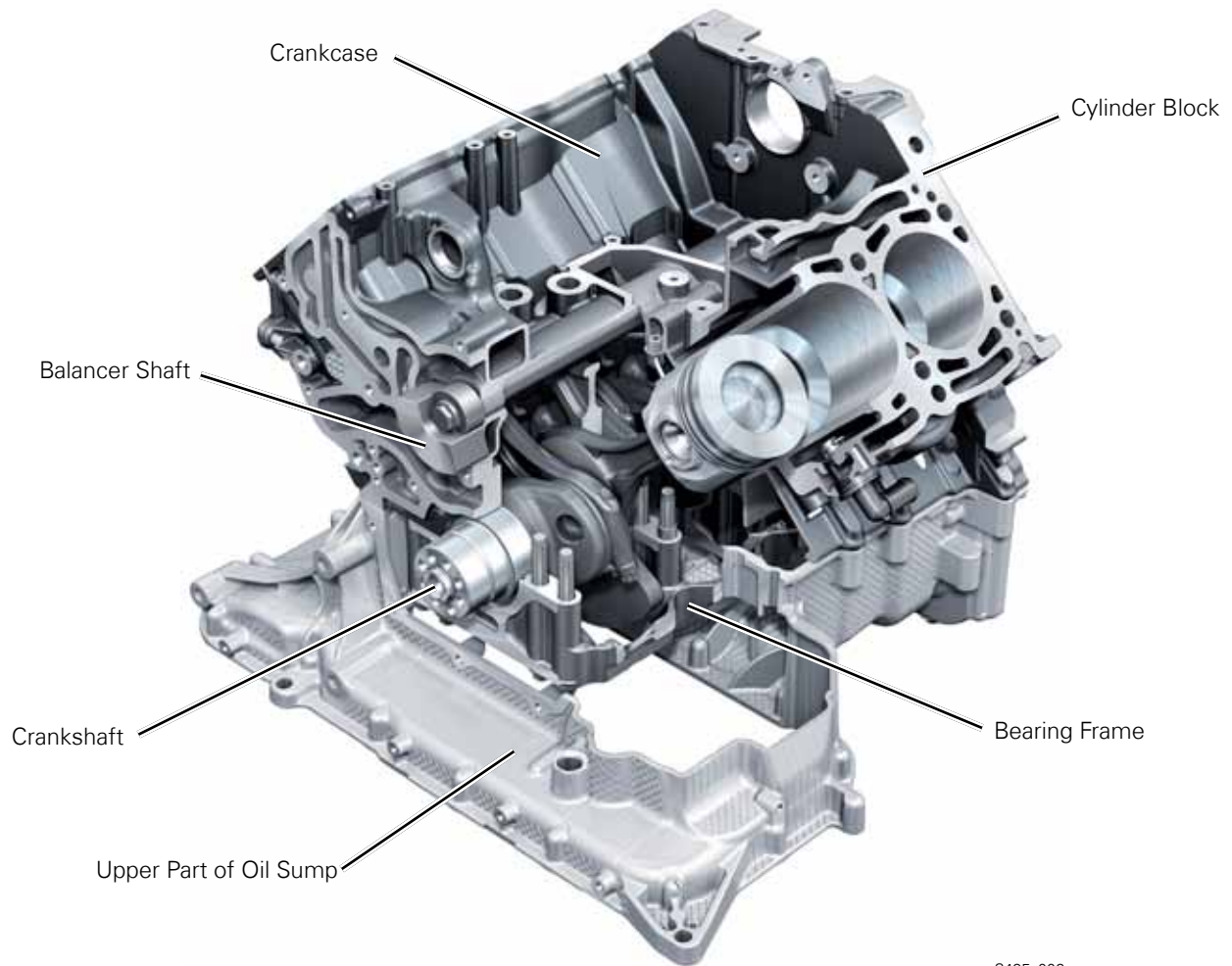

S495_006

The basic design of the crankcase is the same as the previous engine, with high strength and high load-bearing capabilities.

The bearing frame design is also the same for strength reasons. The weight of the crankcase has been reduced by approximately 8kg (17 lb) by reducing the wall thicknesses throughout the crankcase.

The deck-plate honing method has been used for the cylinder bores. This creates an optimum cylinder shape, allowing for lower piston ring tension. This reduces blow-by rates and decreases mechanical friction

Engine Mechanics

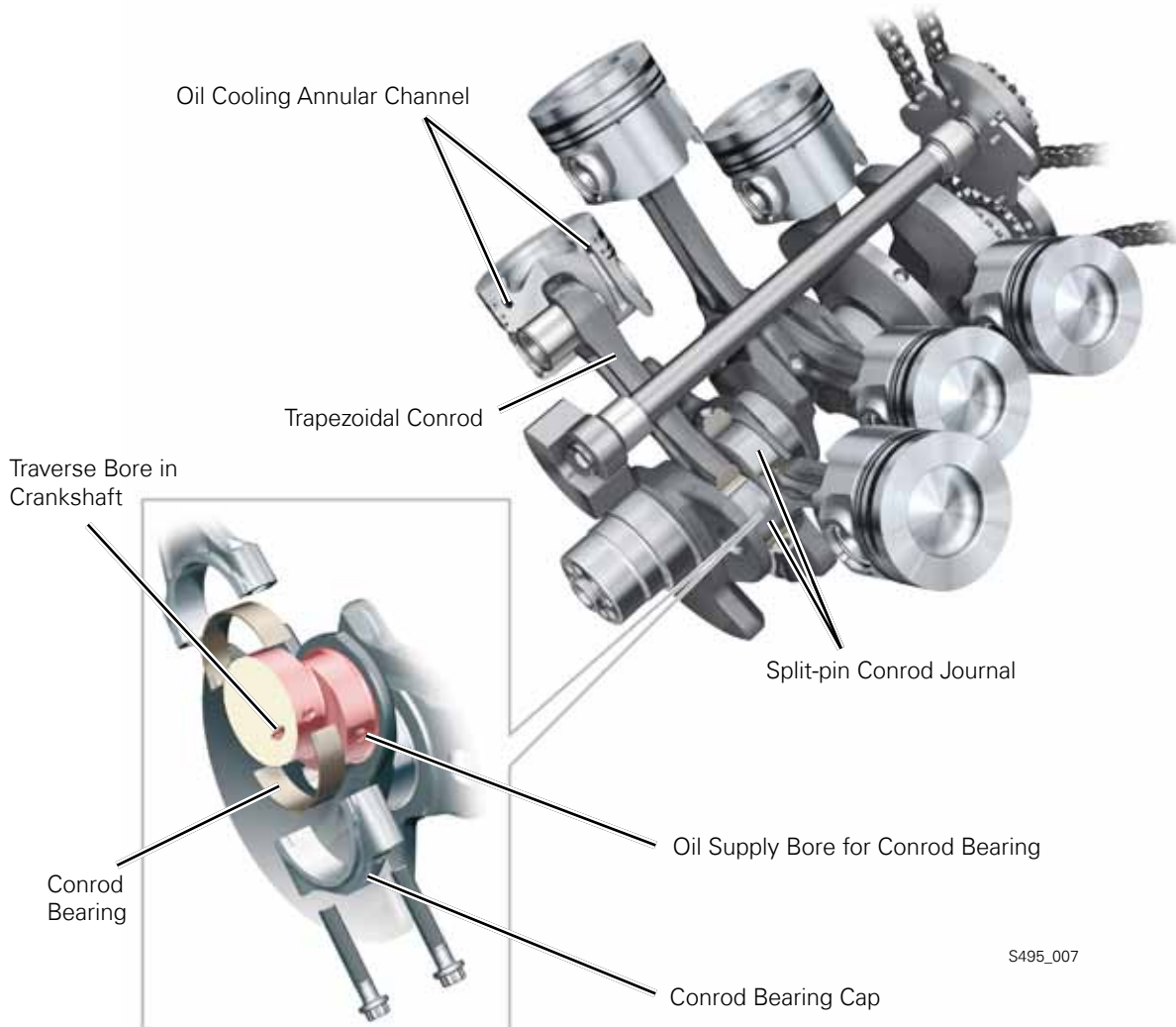

The forged crankshaft uses a split-pin design in the 90° V engine for equal firing intervals and to reduce engine noise. Both the main bearing and the conrod bearing journals are induction hardened for strength.

The forged conrods are split diagonally and industrially cracked. The aluminium pistons use a salt-core cooling gallery and splash oil cooling for optimum cooling of the piston crown and piston rings.

Chain Drive

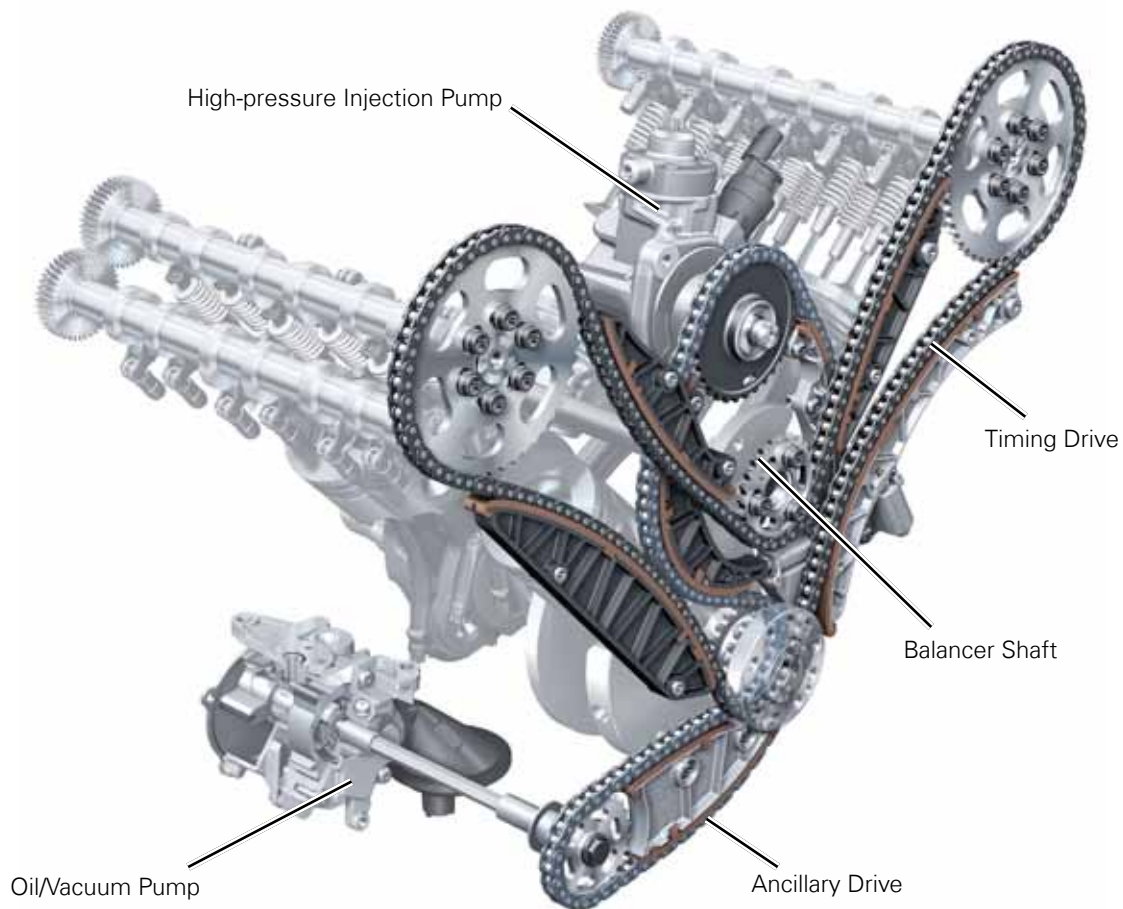

S495_008

A relatively long roller chain with 206 links is used to drive the two inlet camshafts and the balance shaft. The chains have a wear-resistant coating. This reduces chain stretch over time.

The ancillary drive chain is also a roller chain. It drives the high-pressure injection pump, the oil pump and the vacuum pumps (combined in one housing).

The new chain layout has two chains and two chain tensioners instead of four of each. Also, two idler gears have been removed.

The new drive system for the high-pressure pump removes a toothed belt, simplifying assembly and reducing friction and weight.

Engine Mechanics

Cylinder Head

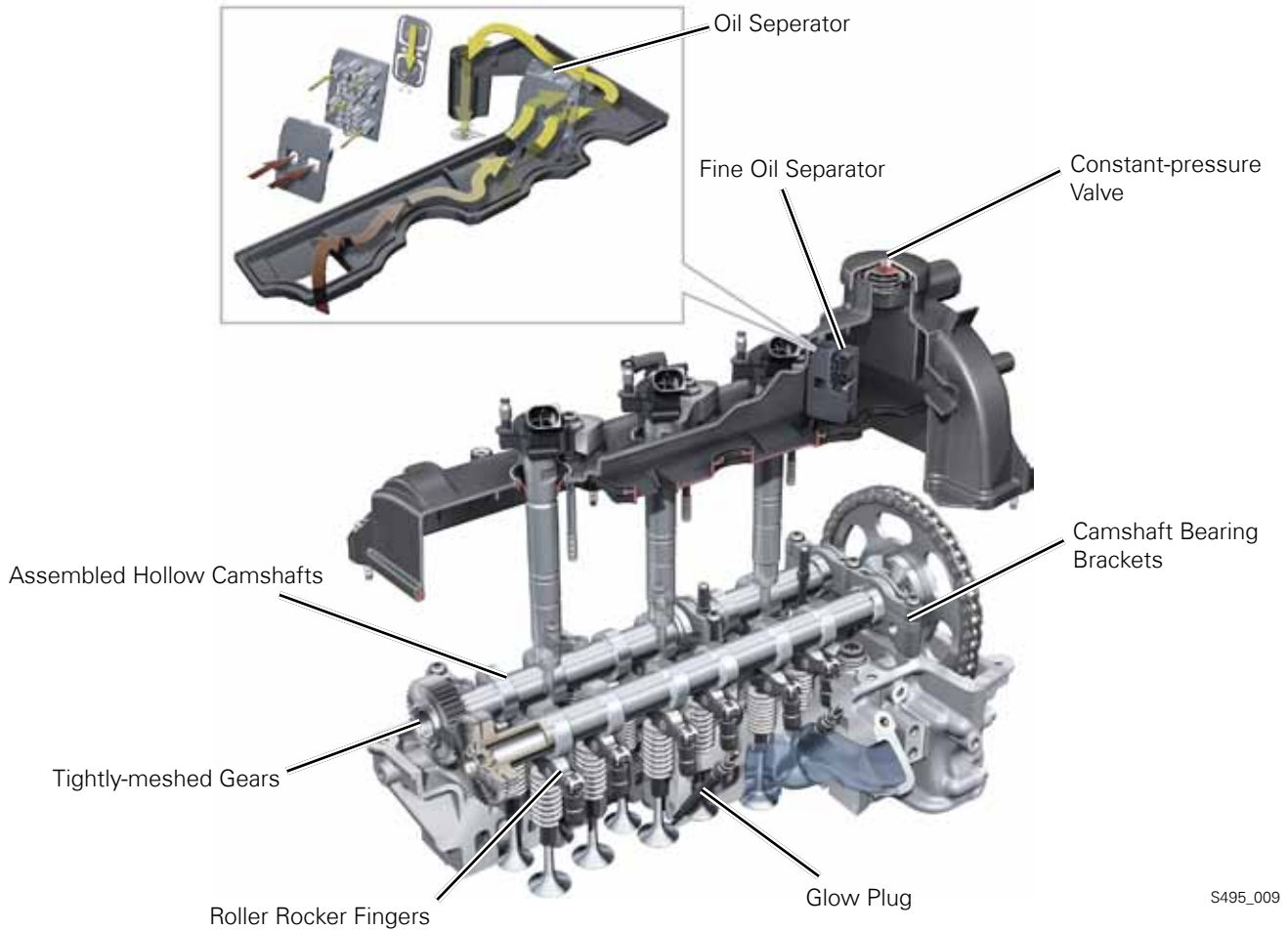

The four-valve combustion design is carryover from the previous engine with one tangential and one filling port on the inlet side and two combined exhaust ports. The inlet ports have been improved in terms of swirl and gas flow. The cooling concept of the cylinder head has been changed to keep the combustion chamber temperatures at an acceptable level. The exhaust ports are positioned further apart and made smaller to increase the size of the coolant chamber. Also, the coolant chamber has been designed for consistent volume and flow speed in areas close to the combustion chambers. The coolant enters on the exhaust side using three separate ports for each cylinder.

The main flow is guided between the exhaust valves and is then branches into the areas between valves. The hollow camshafts have with split double bearing brackets (instead of ladder frame). This eliminates the need for special clearances when installing cylinder head bolts.

To reduce noise, the exhaust camshafts are driven by tightly meshed gears. The bearing diameter of the camshafts has been reduced from 32 to 24 mm (1.26 to 0.9 in) to reduce friction.

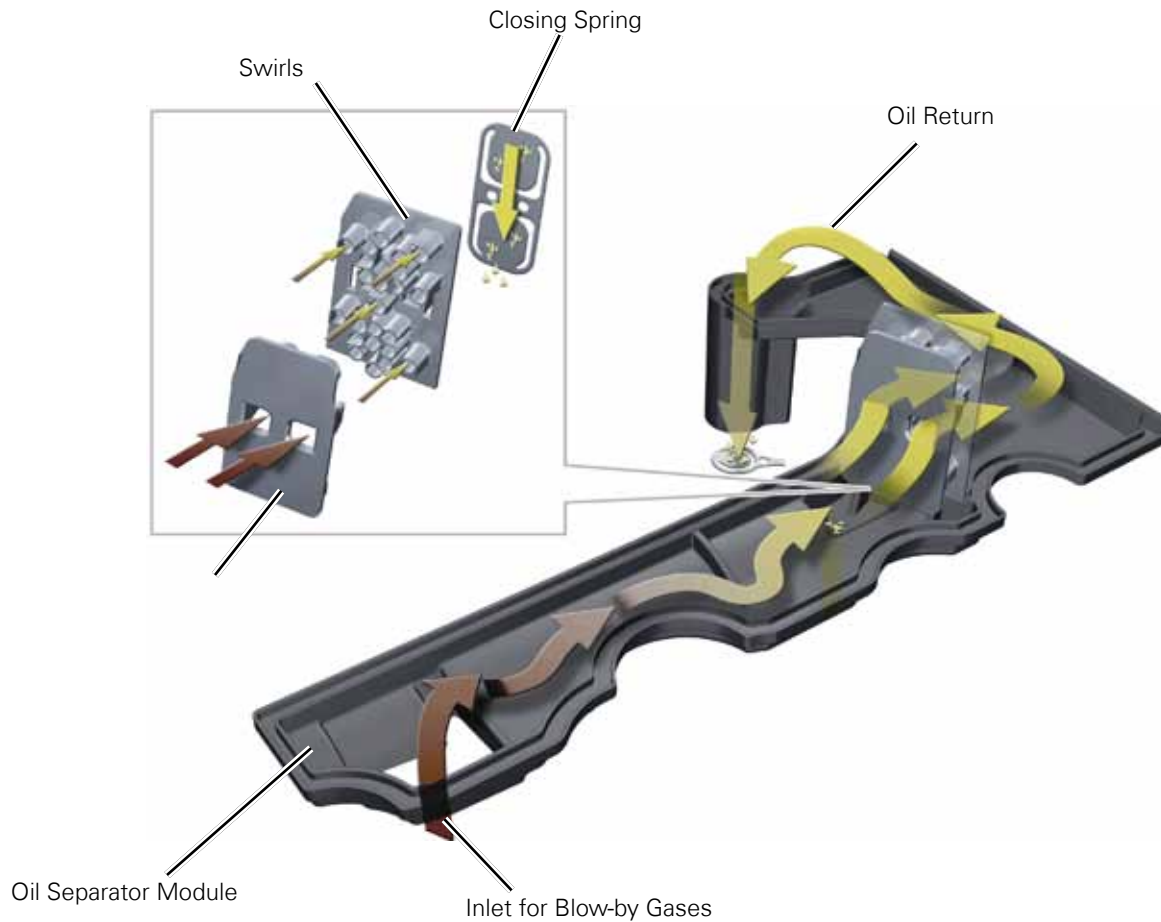

S495_039

The engine breather system has been moved from the inner V to the cylinder heads. Coarse and fine oil separators are integrated into both cylinder head covers. The crankcase breathers run via the pressure regulating valve to the suction side of the turbocharger.

Engine Mechanics

Oil System

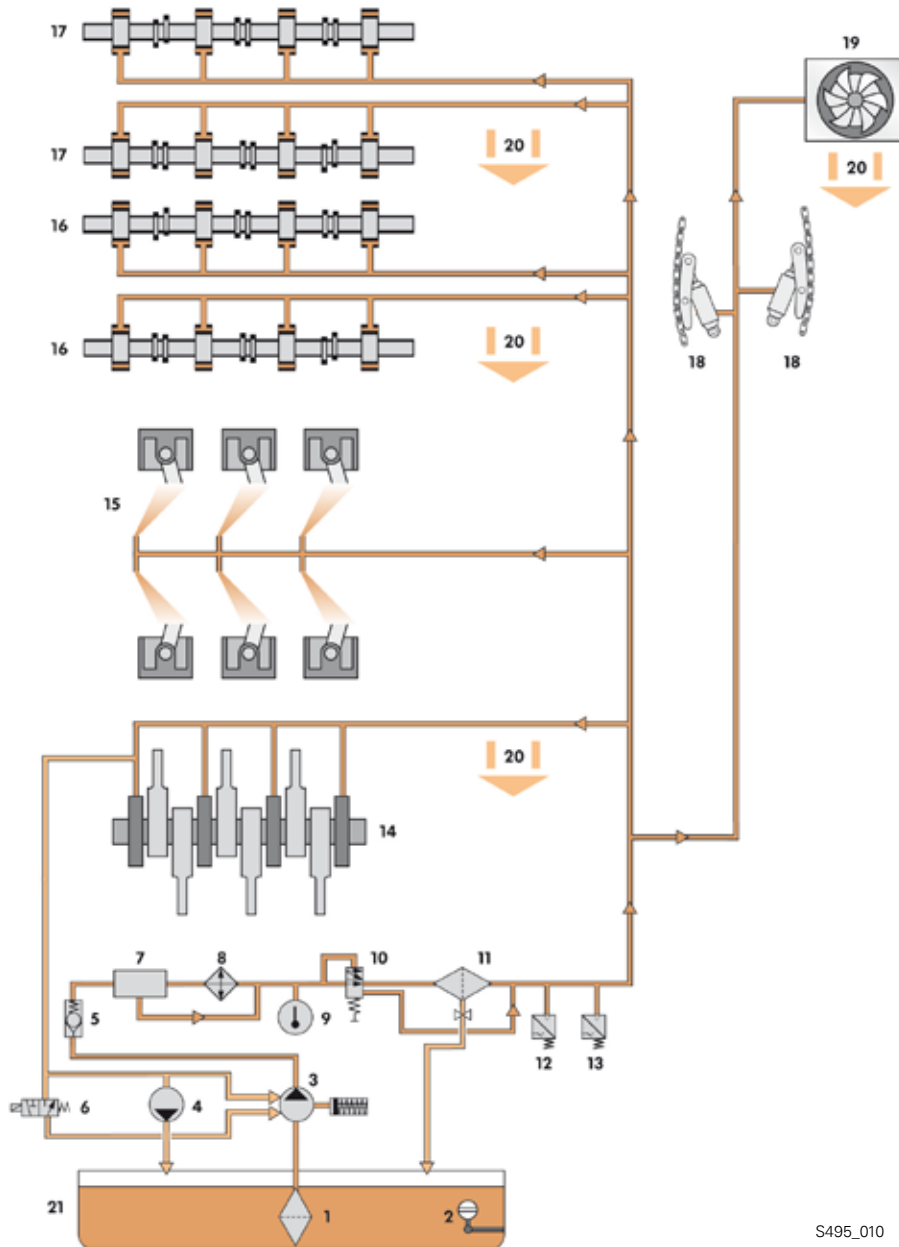

S495_010

- | | |
|---------------------------------------|--------------------------------------|
| 1. Pickup Screen | 11. Oil Filter |
| 2. Oil Level Thermal Sensor G266 | 12. Reduced Oil Pressure Switch F378 |
| 3. Oil Pump | 13. Oil Pressure Switch F22 |
| 4. Vacuum Pump | 14. Crankshaft |
| 5. Non-return Valve | 15. Spray Jets for Piston Cooling |
| 6. Oil Pressure Regulation Valve N428 | 16. Camshafts for Cylinder Bank 1 |
| 7. Thermostat | 17. Camshafts for Cylinder Bank 2 |
| 8. Engine Oil Cooler | 18. Chain Tensioner |
| 9. Oil Temperature Sensor G8 | 19. Turbocharger |
| 10. Filter Bypass Valve | 20. Oil return |
| | 21. Sump |

Volumetric Flow-controlled Oil Pump with Vacuum Pump

The oil pump with two pressure stages from the 4.2L V8 TDI engine is also used on the new 3.0L V6 TDI engine.

The volumetric flow-controlled vane pump can change the oil supply using an eccentrically mounted adjusting ring. The oil pump switches between the pressure stages depending on the engine load, engine speed and the oil temperature.

The oil pump and the vacuum pump are combined in one housing. The two pumps are driven by the chain drive system on the gearbox side through a stub shaft. The vacuum pump produces the vacuum by means of a rotor with adjustable vanes.

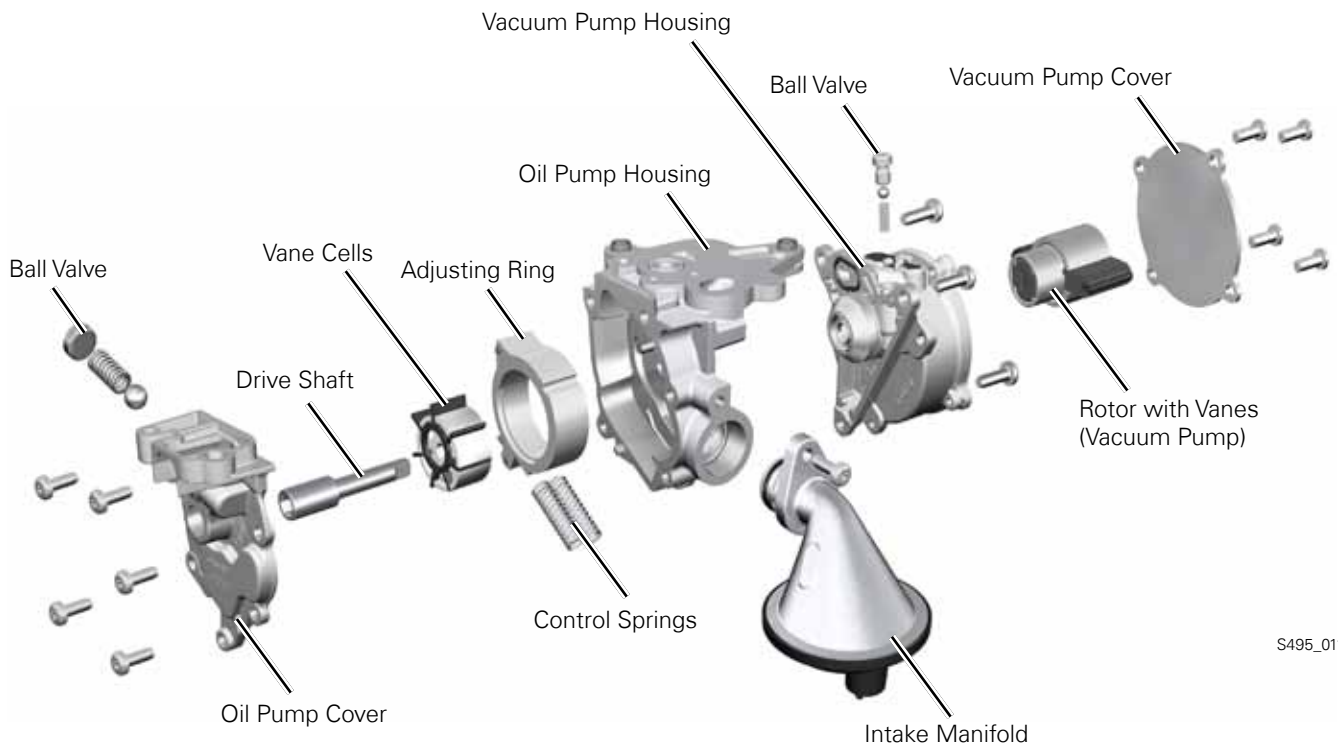

S495_011

Engine Mechanics

Oil Level Sensor

An electronic oil level sensor is used in 3.0L V6 TDI engines. There is not a conventional oil dipstick. The oil level sensor works with ultrasound. The ultrasonic pulses are reflected by the boundary layer of oil and air.

Oil Level Sensor

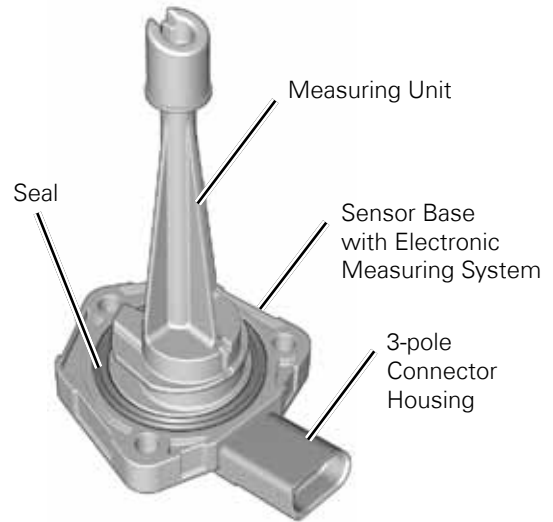

S495_012

Operating Principle

The oil level is calculated from the time difference between the transmission and the return of the pulse. A PWM (Pulse Width Modulated) signal represents the oil level.

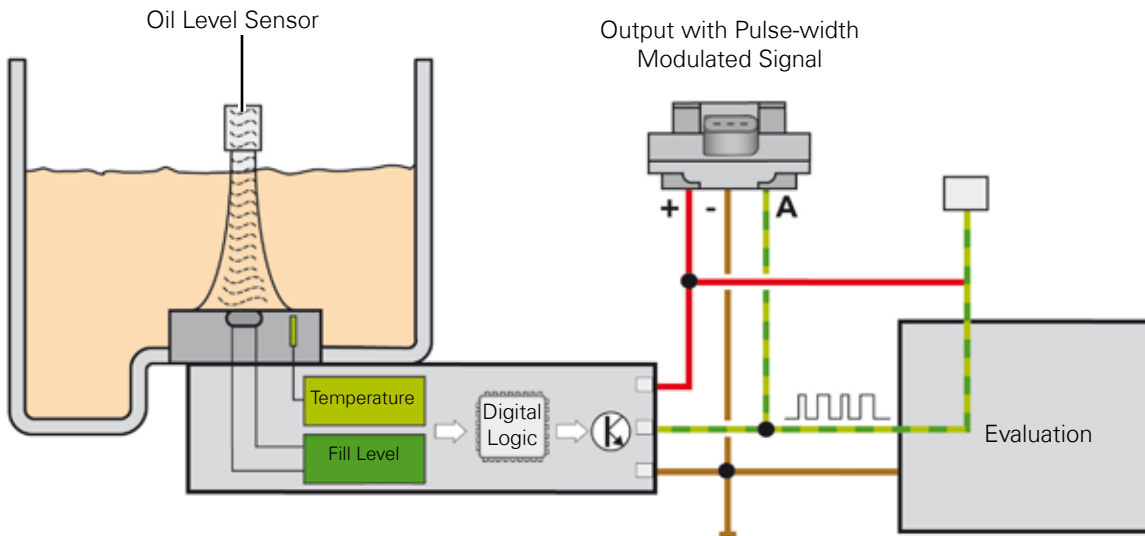

S495_040

Air Intake

The intake air reaches the throttle valve through a plastic air duct. Recirculated exhaust gases are fed into the intake connecting pipe in a way that assists the air flow.

When the exhaust gases are fed in, deposits on the inside plastic wall are avoided due to the geometric shape.

In previous engines, six flaps were used for swirl regulation. This engine only uses one flap because the intake manifold has two air paths from the swirl flap to the two cylinder banks. The upper part leads the flow of air to the swirl ports and the lower part goes to the filling ports.

The intake manifold geometry has been improved to control pressure loss and to evenly distribute air flow to the individual cylinders. The reduction in pressure losses improves performance and consumption.

The plastic intake manifold consists of three shells and is friction welded.

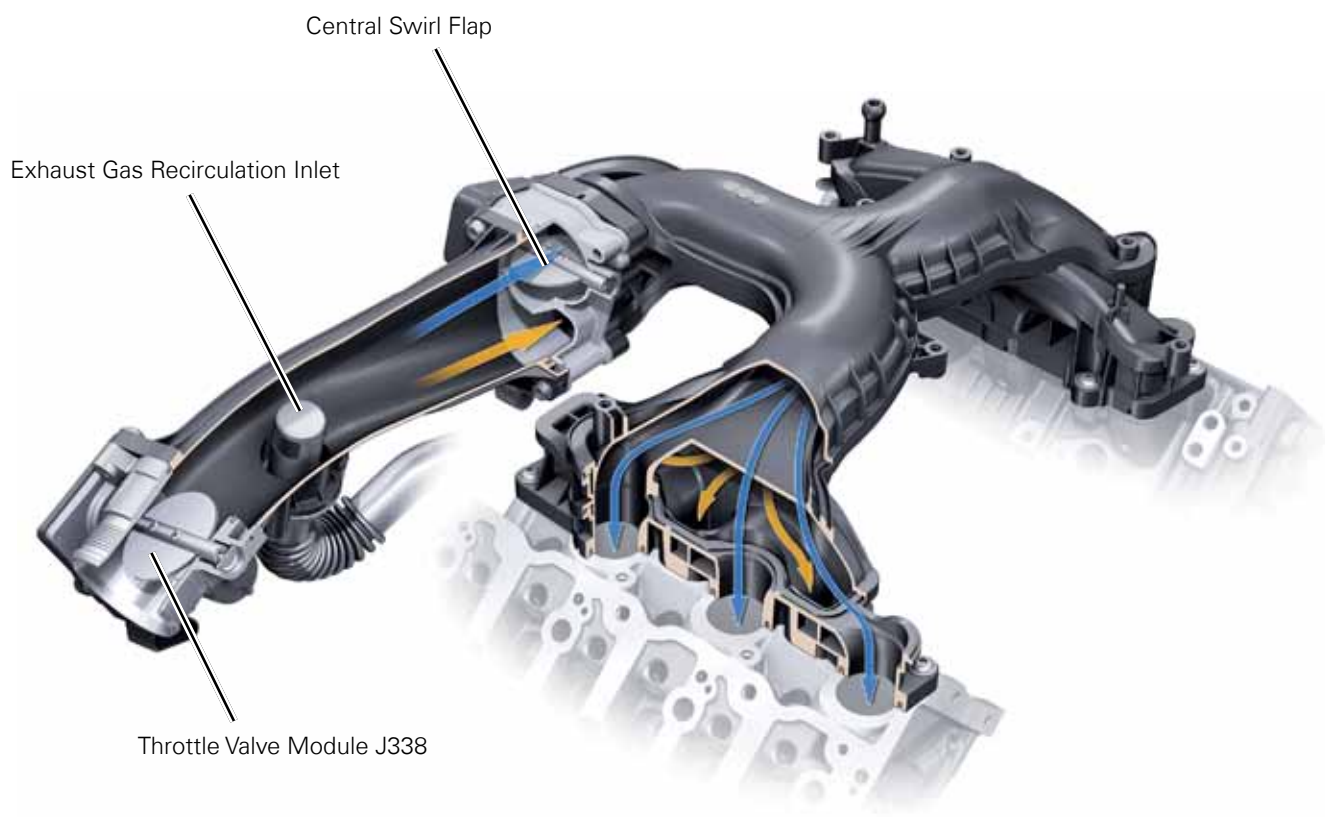

Engine Mechanics

Exhaust Gas Recirculation (EGR)

The exhaust gas recirculation system plays a decisive role in meeting the emissions standards. The components of the exhaust gas recirculation system such as the exhaust gas recirculation valve, exhaust gas recirculation cooler and bypass valve, are combined in the EGR module.

The EGR system collects the exhaust gases at the turbocharger housing. It has been optimized to reduce pressure losses related to high recirculation rates. Despite the omission of the separate low-temperature coolant circuit, this engine has the same EGR cooling performance as the previous engine.

The exhaust gas recirculation cooler is now incorporated into the cylinder head circuit and is no longer supplied with cold coolant from the main radiator. This causes the temperature of the coolant supplied to the EGR cooler system to rise. The cooling performance of the exhaust gas recirculation cooler has, however, been increased by approx. 1 kW. As a result, it was possible to slightly increase the cooling performance of the whole system.

The advantage of the new EGR cooling system is its greatly reduced complexity. This includes the incorporation of the EGR coolant circuit into the cylinder head circuit of the new dual-circuit cooling system. It is also much lighter.

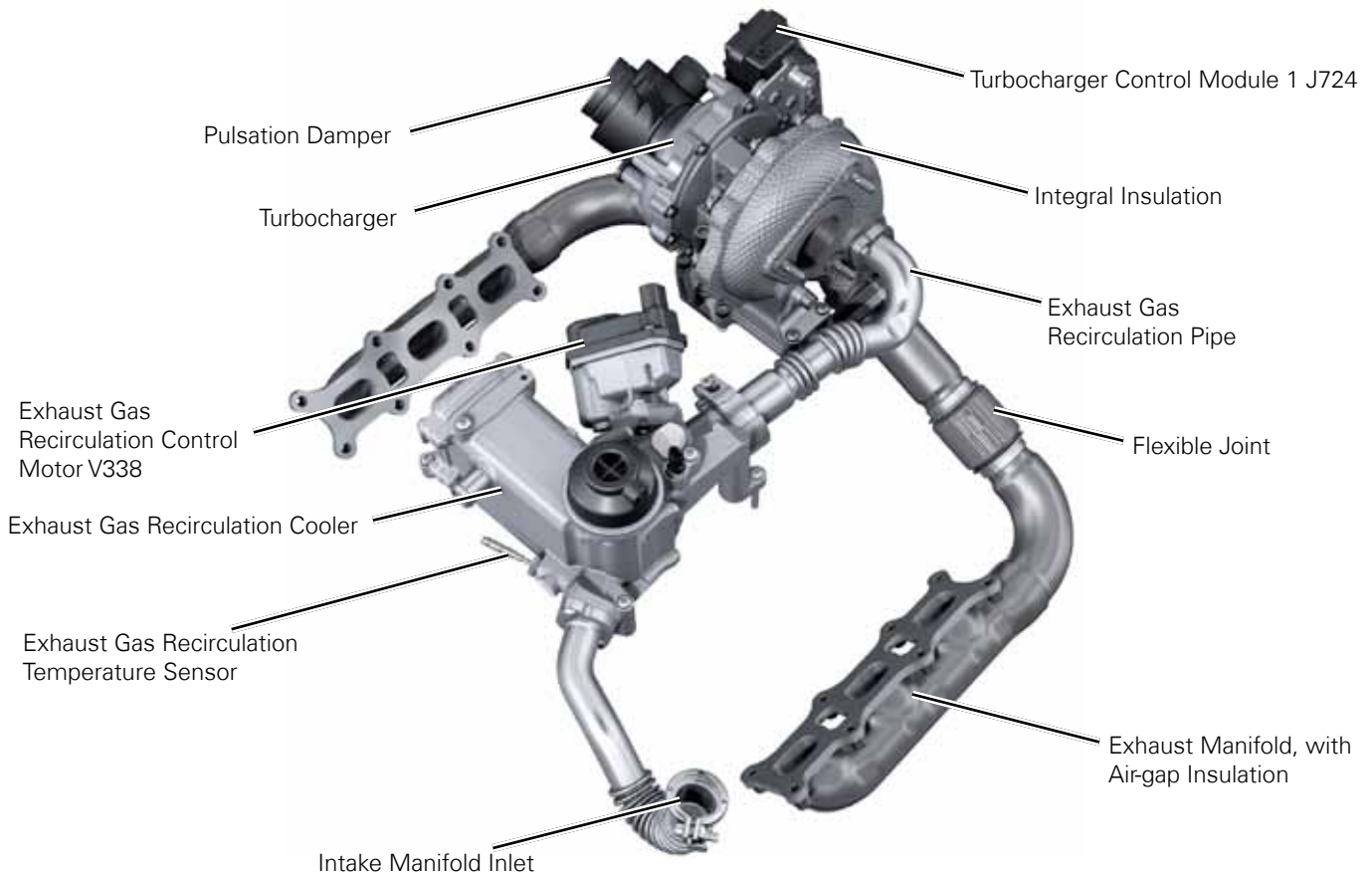

S495_014

Cooler for Exhaust Gas Recirculation

The electrically operated exhaust gas recirculation valve is located on the “hot side” of the engine. To reduce pressure loss, the seat diameter of the valve has been enlarged from 27 to 30 mm.

The high-performance exhaust gas recirculation cooler is made from stainless steel and is integrated into the aluminium housing of the EGR module. A pneumatic lift valve is used instead of a flap to bypass the cooler when necessary.

Compared with a flap that inevitably always has a gap, a lift valve guarantees a tight seal during cooling operation. This enables maximum cooling performance. An EGR Temperature Sensor G98 is built into the exhaust gas outlet of the EGR module. The exhaust gas temperature downstream of the cooler is regulated to a minimum value with this temperature sensor. This allows maximum EGR cooling to minimise NO_x emissions and to prevent the formation of condensation.

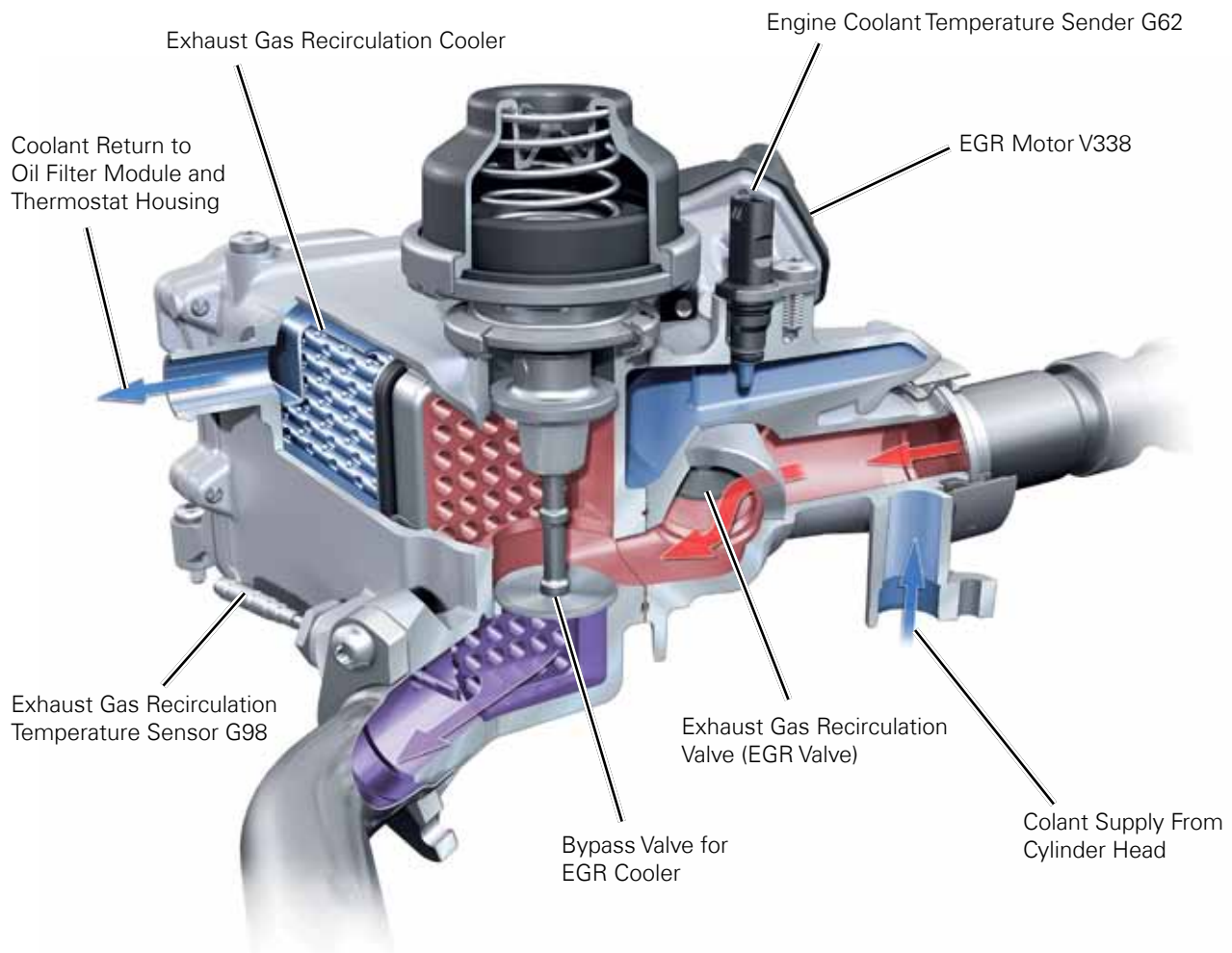

S495_015

Engine Mechanics

Turbocharger

The turbocharger has is a Honeywell GT 2260 turbocharger with increased performance. The turbocharger has been optimized in many areas. Both the compressor wheel and turbine have been modified and the rotating parts have been altered reduce friction. This allows fast response and an even torque delivery.

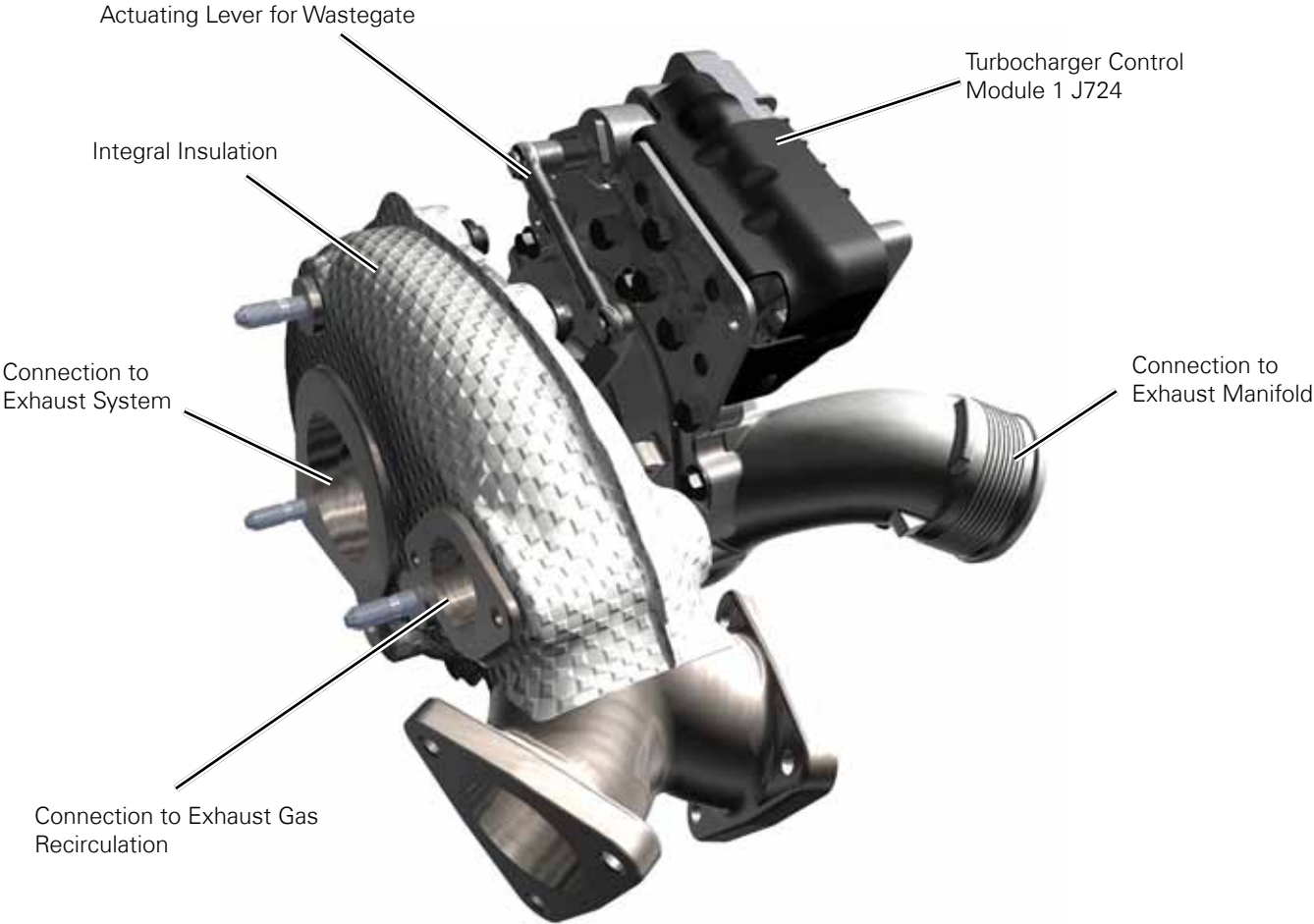

Charge Air Cooling

The charge air system has been revised from the air filter to the turbocharger. On the pressure side, low-turbulence hose connections are used to improve airflow, reducing consumption while improving engine response time.

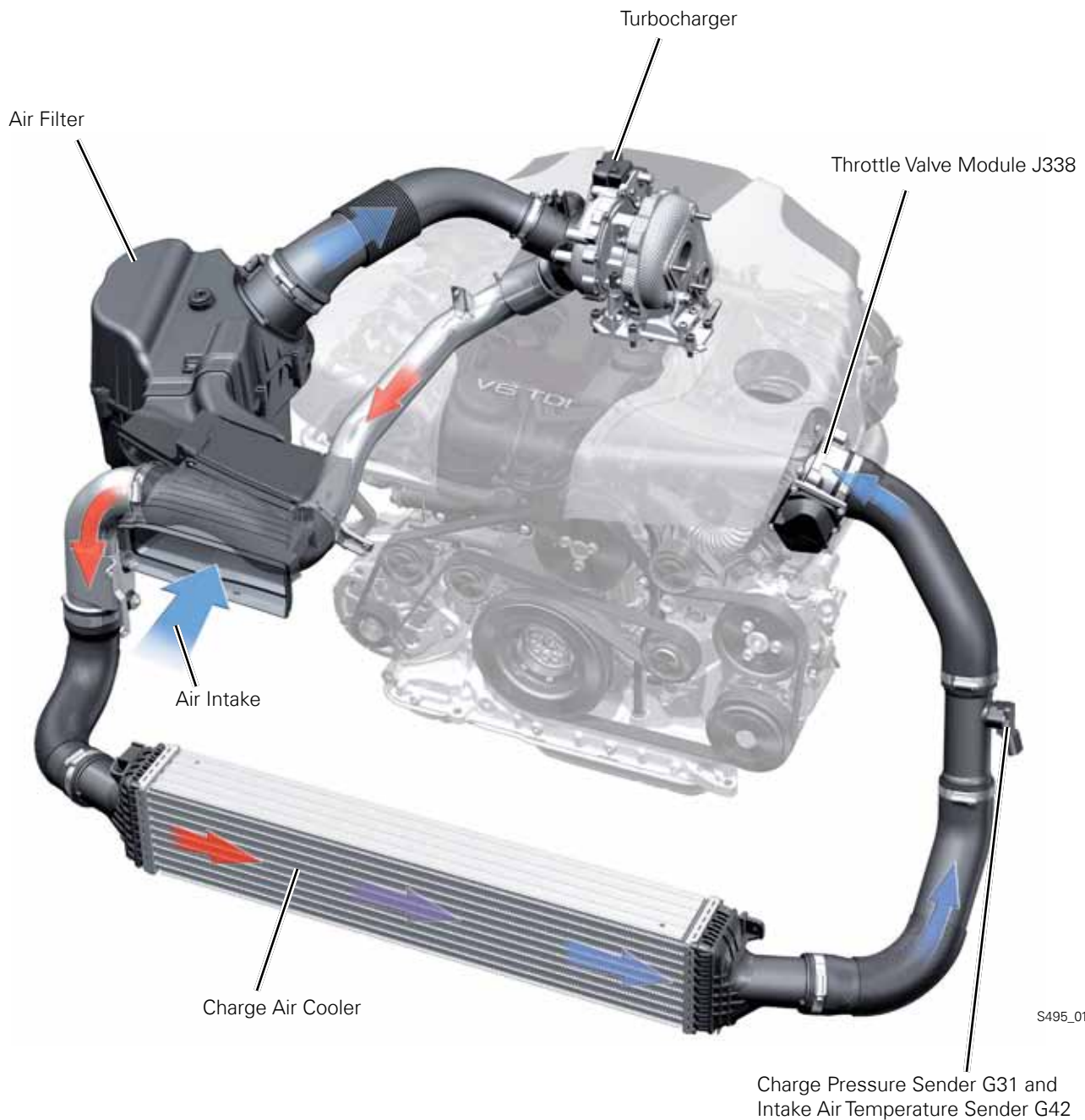

Engine Mechanics

Cooling System

Cylinder Head Coolant Circuit

The cylinder head coolant circuit is made up of coolant chambers in the cylinder heads, the exhaust gas recirculation cooler, the oil cooler, the heating and transmission oil heat exchanger and the main radiator. The cylinder head coolant circuit is regulated by a wax thermostatic element.

The thermostat is not energized during the warm-up phase of the engine and opens at approx. 90° C (194° F). No heat is transferred to the main radiator until this temperature is reached. The coolant is only used to warm the transmission and the HVAC system (if necessary).

Energizing the wax thermostatic element allows coolant to be exchanged between the radiator and the cylinder head for:

- Cylinder Head Component Protection
- Maximum EGR Cooling Requirement
- Transmission Cooling Requirement

Pneumatic Regulating Valve
(Operation of the Cylinder Head and
Cylinder Block Coolant Circuit)

Engine Oil Cooler

Cylinder Block Coolant Circuit Closed

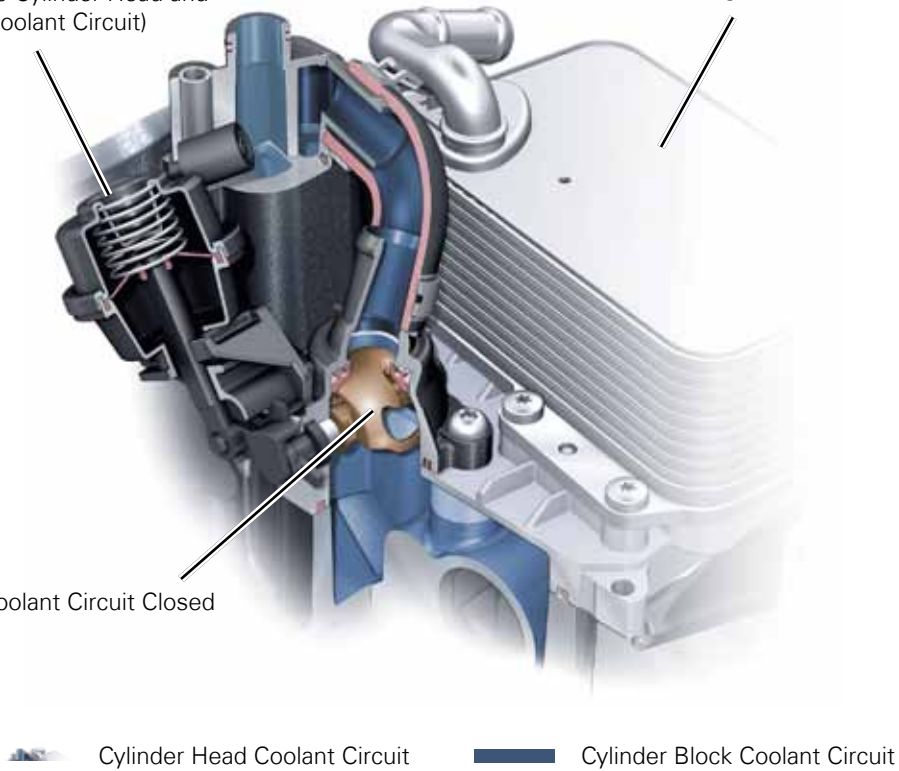

S495_019

Cylinder Block Coolant Circuit

The coolant for the cylinder block coolant circuit reaches the exhaust side of the cylinder banks through non-return valves in the cylinder block. The non-return valves prevent return flow of coolant between the cylinder banks and unwanted heat transfer from the cylinder block, controlling the flow in the circuit. The cylinder block coolant circuit is closed by a vacuum-controlled ball valve. This allows the coolant to be heated quicker, shortening the warm-up phase of the engine and reducing friction.

The temperature level of the cylinder block coolant circuit is regulated at approx. 105° C (221° F). This allows the rotating assemblies to work at the best possible friction temperature level. The ball valve is activated by the Cylinder Head Coolant Valve N489 using pulse-width modulation (PWM). To help the system warm up quickly, an engine oil cooler bypass is also located in the oil system.

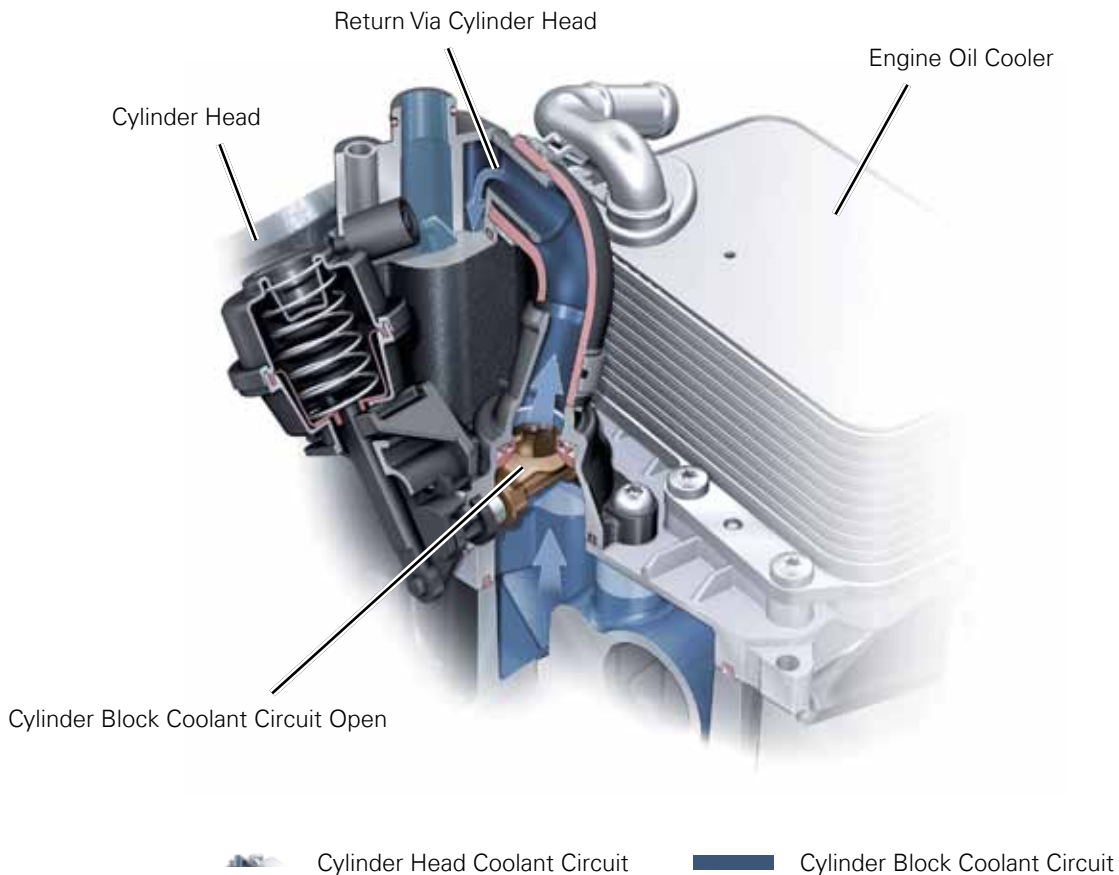

S495_020

Engine Mechanics

Bleeding the System

The cylinder block coolant circuit has its own bleeder valve. This allows air bubbles in the cylinder block circuit to escape at the highest point of the system even when the coolant is stationary.

The bleeder lines run from the coolant circuits to a bleeder valve. The bleeder valve connects the cylinder head coolant circuit to the bleeder system of the cylinder block circuit. The valve seals the two sub-circuits from each other with the aid of a floating ball.

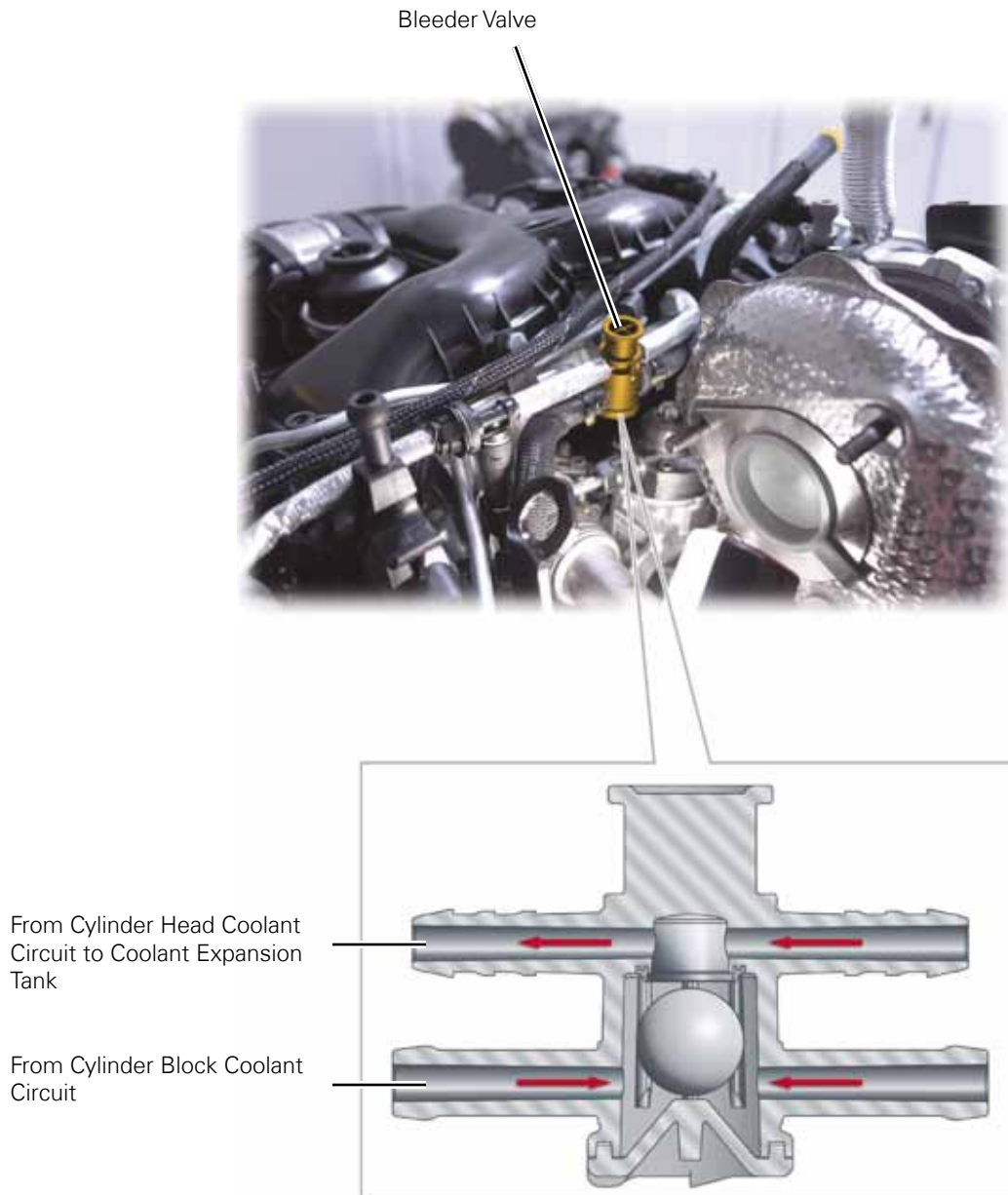

S495_021

Engine Oil Cooler with Thermostat-controlled Bypass Channel

The engine oil cooler is equipped with a thermostat-controlled oil cooler bypass.

Design

Mount for Coolant Pump Drive Wheel

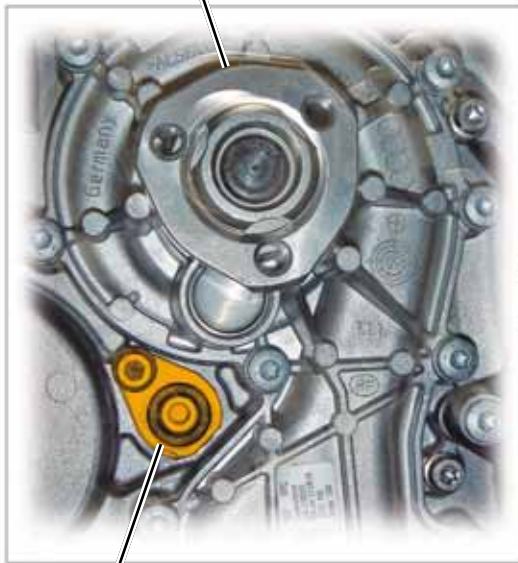

Thermostat



S495_022

Engine Mechanics

Function

The expanding wax element in the thermostat opens a bypass valve at the engine oil cooler when the oil temperature is $< 103^{\circ}\text{C}$ (217°F). The main flow of oil is sent past the engine oil cooler. The thermostat is located below the coolant pump on the cylinder block.

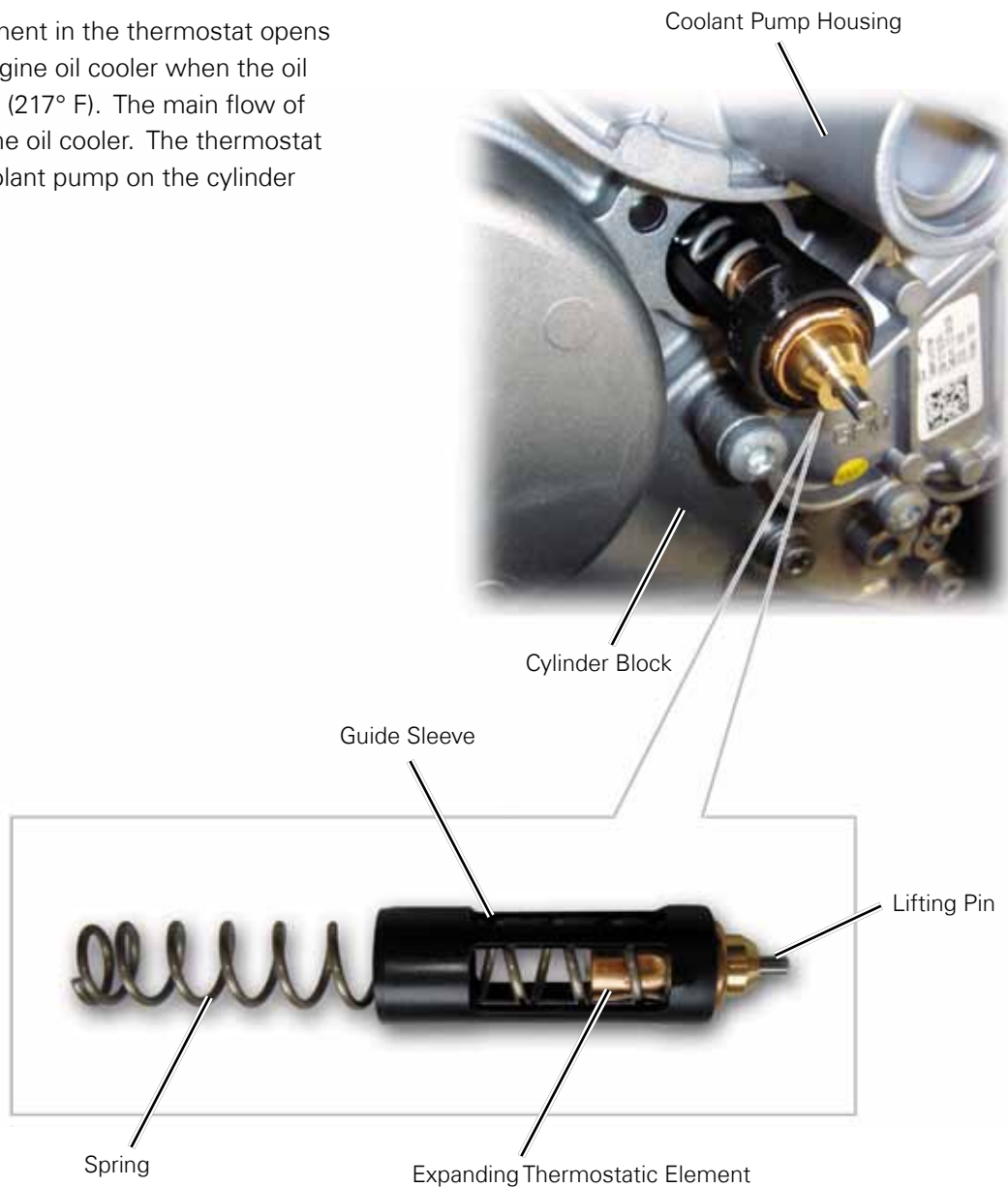

S495_023



Page intentionally left blank

Engine Mechanics

Innovative Thermal Management System for 3.0L V6 TDI Engine (Generation 2)

The purpose of the thermal management system is to reduce the warm-up time of the engine and control temperatures so that the engine runs at a good friction level.

The cooling system uses a split-cooling concept in which the cylinder block and cylinder head each have their own coolant circuits. This allows the individual temperatures to be set for the cylinder block and cylinder head even when the engine has reached operating temperature.

The coolant pump, which is located at the front of the engine inner V, continuously delivers coolant to the crankcase on the exhaust side of the engine. The flow of coolant is split between the cylinder heads and the crankcase. Once coolant has flowed through the two sub-circuits, the flow of coolant reaches the suction side of the coolant pump.

This split-cooling design also allows independent supply of coolant to the interior and transmission oil heaters regardless of whether the coolant in the cylinder block is stationary.

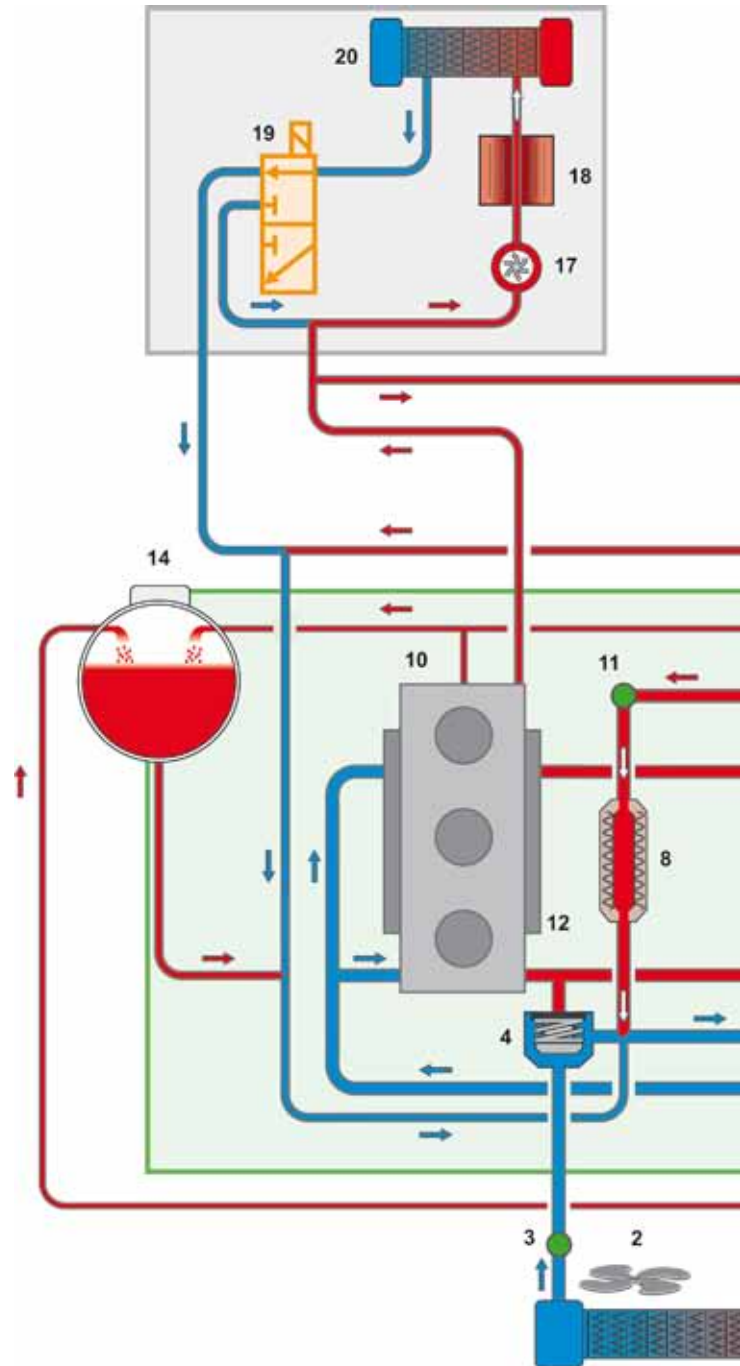

Engine Mechanics



Always follow the instructions in the workshop manual when filling the cooling system.

Key:

1. Radiator
2. Radiator Fan
3. Engine Coolant Temperature Sensor on Radiator Outlet G83
4. Map Controlled Engine Cooling Thermostat F265
5. Coolant Pump
6. Engine Oil Cooler
7. Oil Level Thermal Sensor G266
8. Cooler for Exhaust Gas Recirculation
9. Coolant Shut-off Valve
10. Cylinder Head
11. Engine Coolant Temperature Sender G62
12. Cylinder Block
13. Engine Temperature Control Sensor G694
14. Coolant Expansion Tank
15. ATF Cooler
16. Transmission Coolant Valve N488
17. Coolant Recirculation Pump V50
18. Auxiliary Heater (not for NAR)
19. 3/2-way Valve
20. Heat Exchanger for Heater

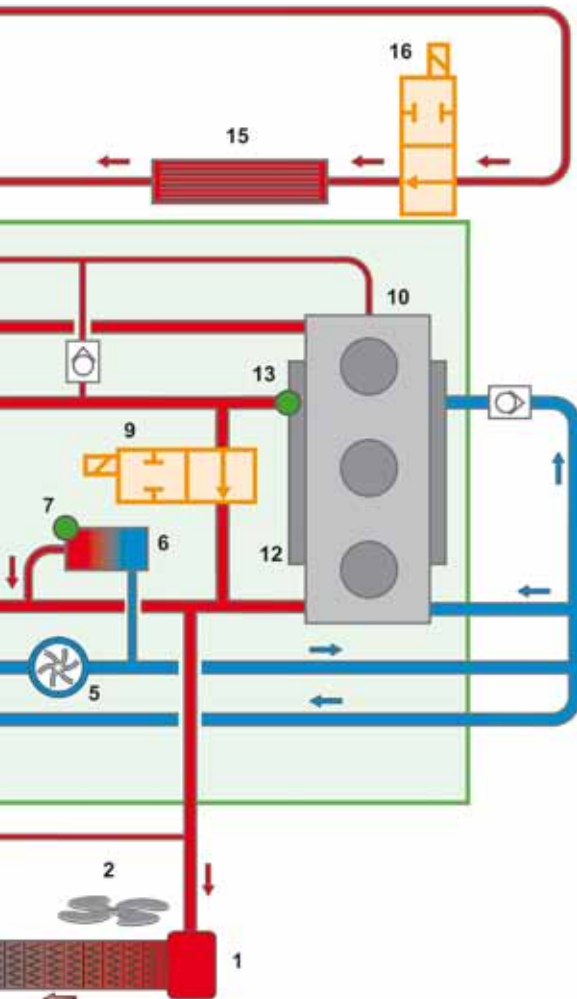

Engine Mechanics

Fuel System

Schematic Overview

1. Fuel Delivery Unit

Constantly delivers fuel to the presupply.

2. Pressure-resistant Fuel Filter

3. Fuel Temperature Sensor G81

Measures the current fuel temperature.

4. Dual-piston High-pressure Pump

Generates the high fuel pressure required for injection.

5. Fuel Metering Valve N290

Regulates the quantity of fuel to be pressurised as required.

6. Pressure Retention Valve/Restrictor

A pressure of 3.5 – 10 bar is present in the return from the injectors.

7. Injectors for Cylinders 1 - 6 N30 - N33, N83, N84

8. Fuel Pressure Sensor G247

Measures the current fuel pressure in the high pressure range.

9. Fuel Pressure Regulator Valve N276

Regulates the fuel pressure in the high-pressure range.

10. High-pressure Accumulator (Rail)

Stores the fuel required for injection into all cylinders at high pressure.

11. Engine Control Module J623

12. Fuel Pump Control Module J538

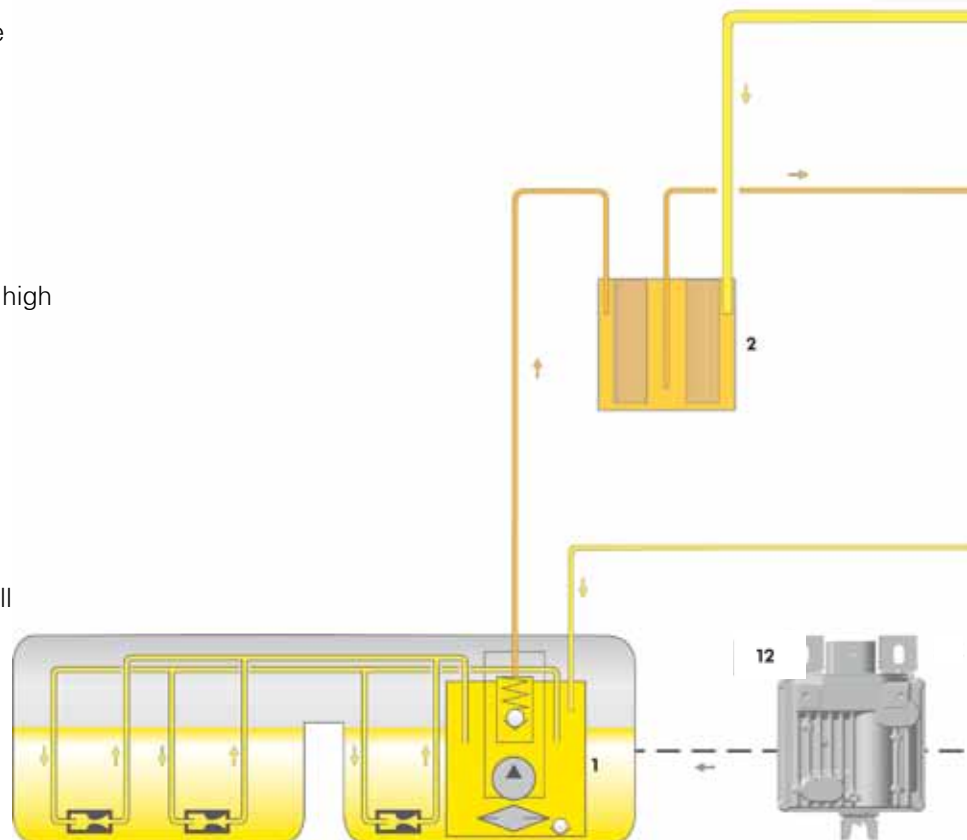
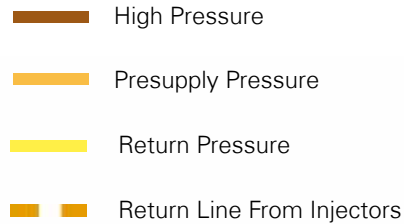

Engine Mechanics

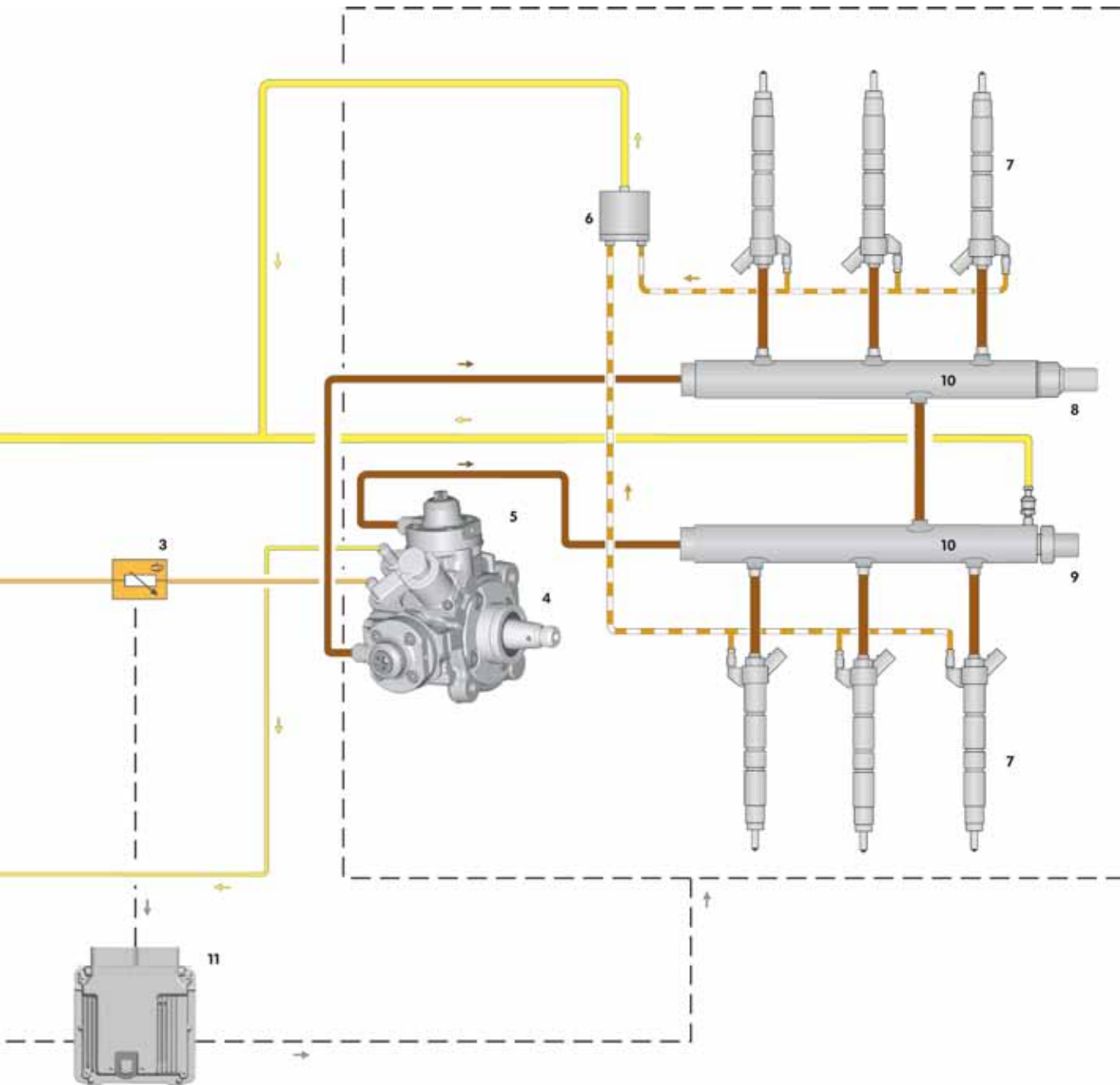

S495_024

Engine Mechanics

Fuel Delivery Unit GX1

The Fuel Delivery Unit GX1 basically consists of two sections:

- The fuel level sender that uses 3-conductor technology and detects the fuel level in the fuel tank.
- The fuel system pressurization pump G6 that uses an EC motor. The EC motor is a brushless, permanently activated synchronous motor.

Thanks to its brushless design, the motor is wear-free except for the bearings. The Transfer Fuel Pump G6 is activated by the Fuel Pump Control Module J538. A PWM signal is used for activation by the Engine Control Module J623. Error feedback messages are sent via the same wires.

This provides a demand-regulated supply of fuel.

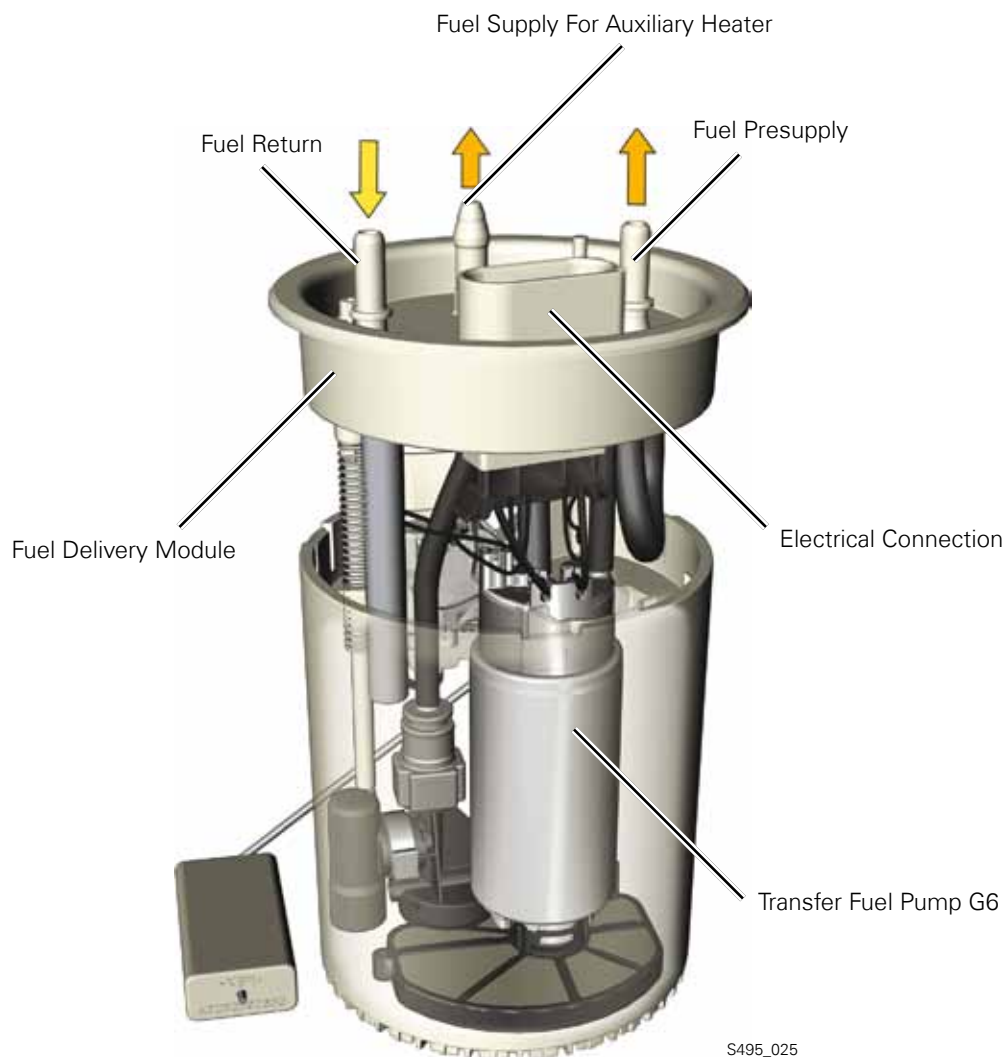

Transfer Fuel Pump G6

The Transfer Fuel Pump G6 uses an EC motor (EC = electronically commutated). The motor is made up of a rotor, stator, pump chamber and housing. The rotor is a permanent magnet and the stator is an electromagnet. The brushless motor in the fuel pump contains two pairs of permanent magnets and three pairs of electromagnets.

The change in the current direction (commutation), which is necessary for rotation, is controlled by an external electronic control unit (Fuel Pump Control Module J538). This design assures no contact between the moving parts of the motor and operation is virtually wear-free.

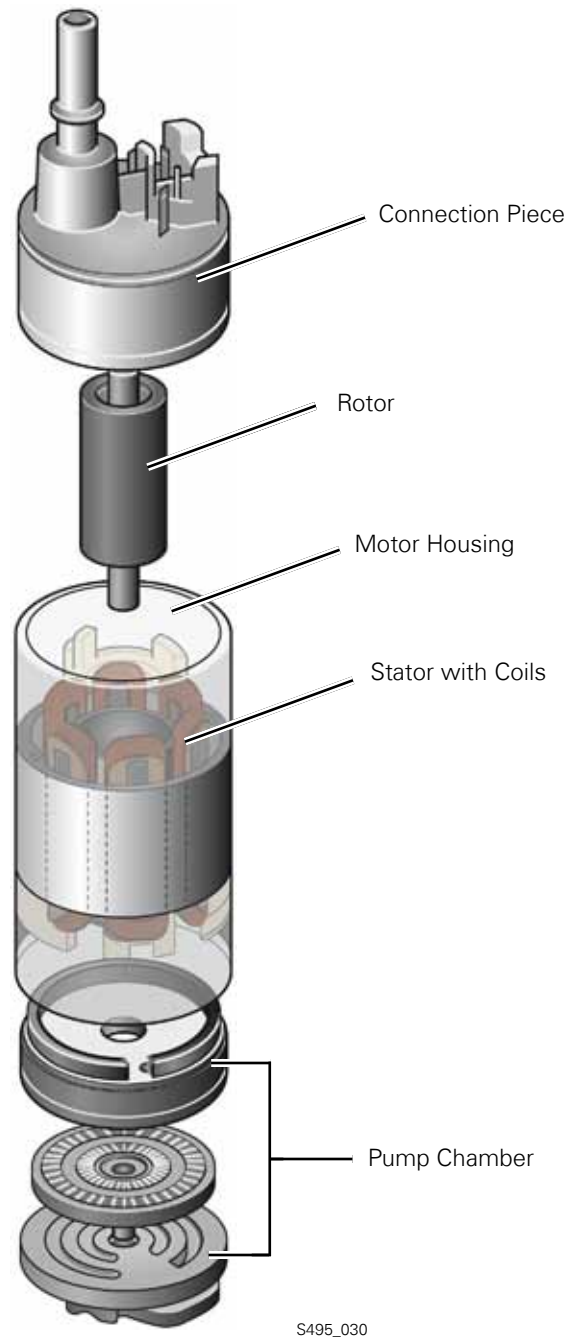

Engine Mechanics

Function of Fuel Pump

The Fuel Pump Control Module J538 switches between phases. The phase switching must be timed precisely in order to create a rotating magnetic field in the stator coil.

The permanent magnet pairs force the rotor to realign itself and follow the magnetic field. This causes rotation. The fuel pump produces mechanical rotation in twelve individual steps. The control module recognizes the position of the rotor from the de-energized coil pair. The Back-EMF Signal (ElectroMotive Force feedback signal) is used for this.

Functional Principle

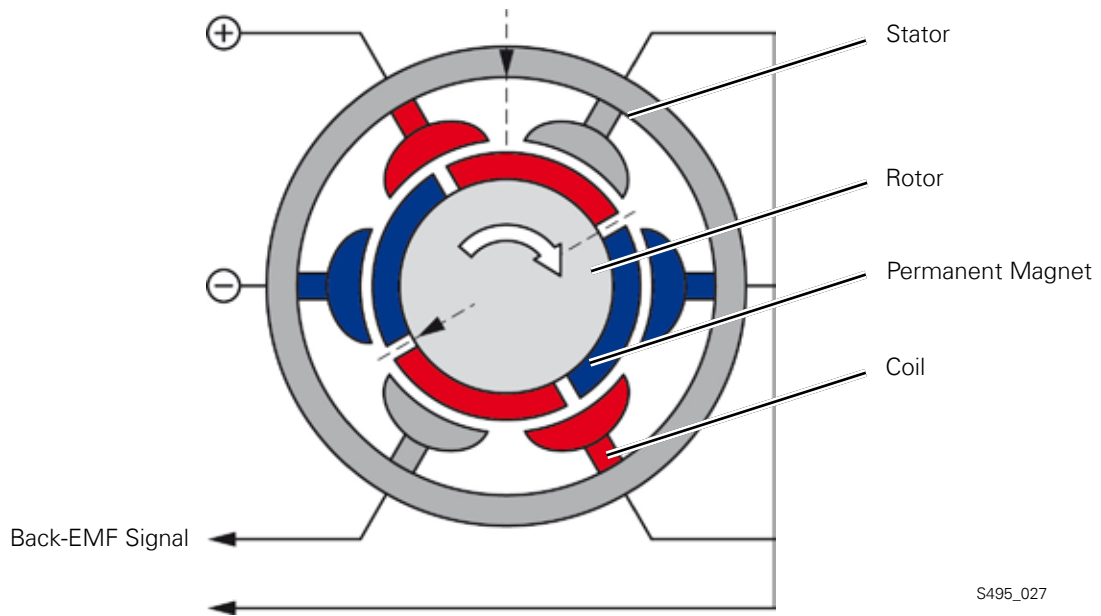

Circuit of Coil Windings

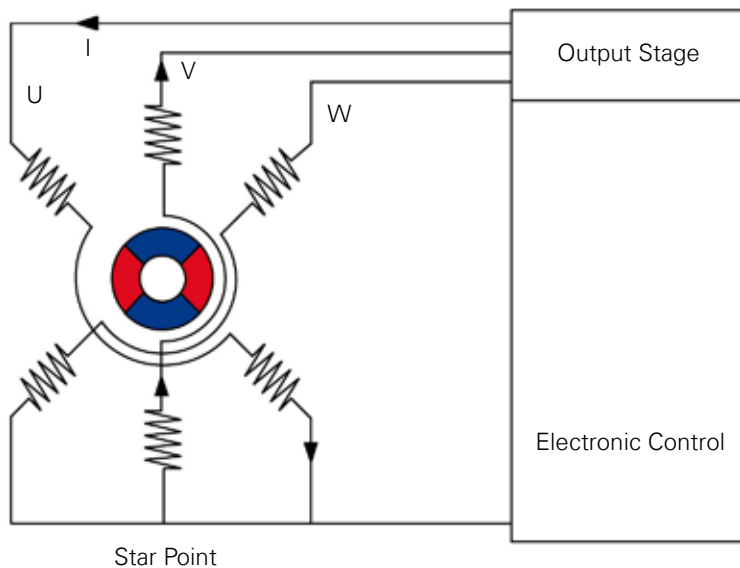

Common Rail Fuel Injection System

The 3.0L V6TDI engine (generation 2) features a Bosch common rail injection system that uses piezo injectors. The maximum injection pressure is 2,000 bar (29,000 psi). Each engine variation has its own injector nozzle configuration.

The piezo injectors are connected to the forged fuel rails with very short injector pipes. The rail pressure is generated by a dual-piston high-pressure pump, the CP 4.2.

The high-pressure pump is located in the inner V on the transmission side. The pump is driven directly by the crankshaft by the ancillary drive chain.

A ratio of 1:0.75 to the crankshaft has been chosen to synchronize fuel delivery with the injectors and to reduce the chain forces.



S495_028

Engine Mechanics

Design of the High-pressure Pump CP 4.2.

The high-pressure pump works with two pistons and is driven by the ancillary drive chain. It generates a maximum injection pressure of 2,000 bar (29,000 psi).



S495_032

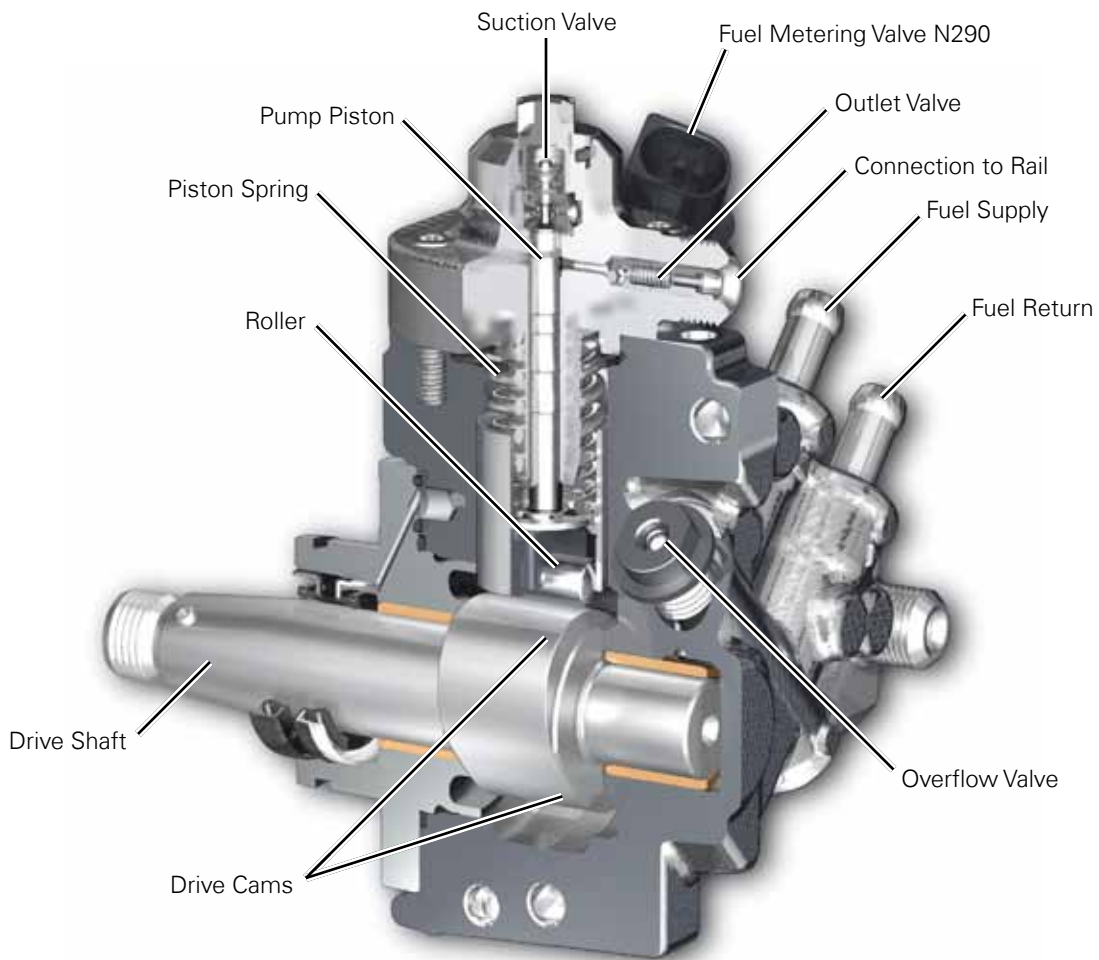

S495_033



The illustration shows a cross-section of the dual-piston high-pressure pump through only one pump piston.

How the High-pressure Pump Works

Suction and delivery strokes are performed one after the other by the pistons, which are offset by 90°. The delivery stroke pushes fuel alternately into the left and right rails. The fuel metering valve distributes fuel evenly between the intake channels for the two pump pistons.

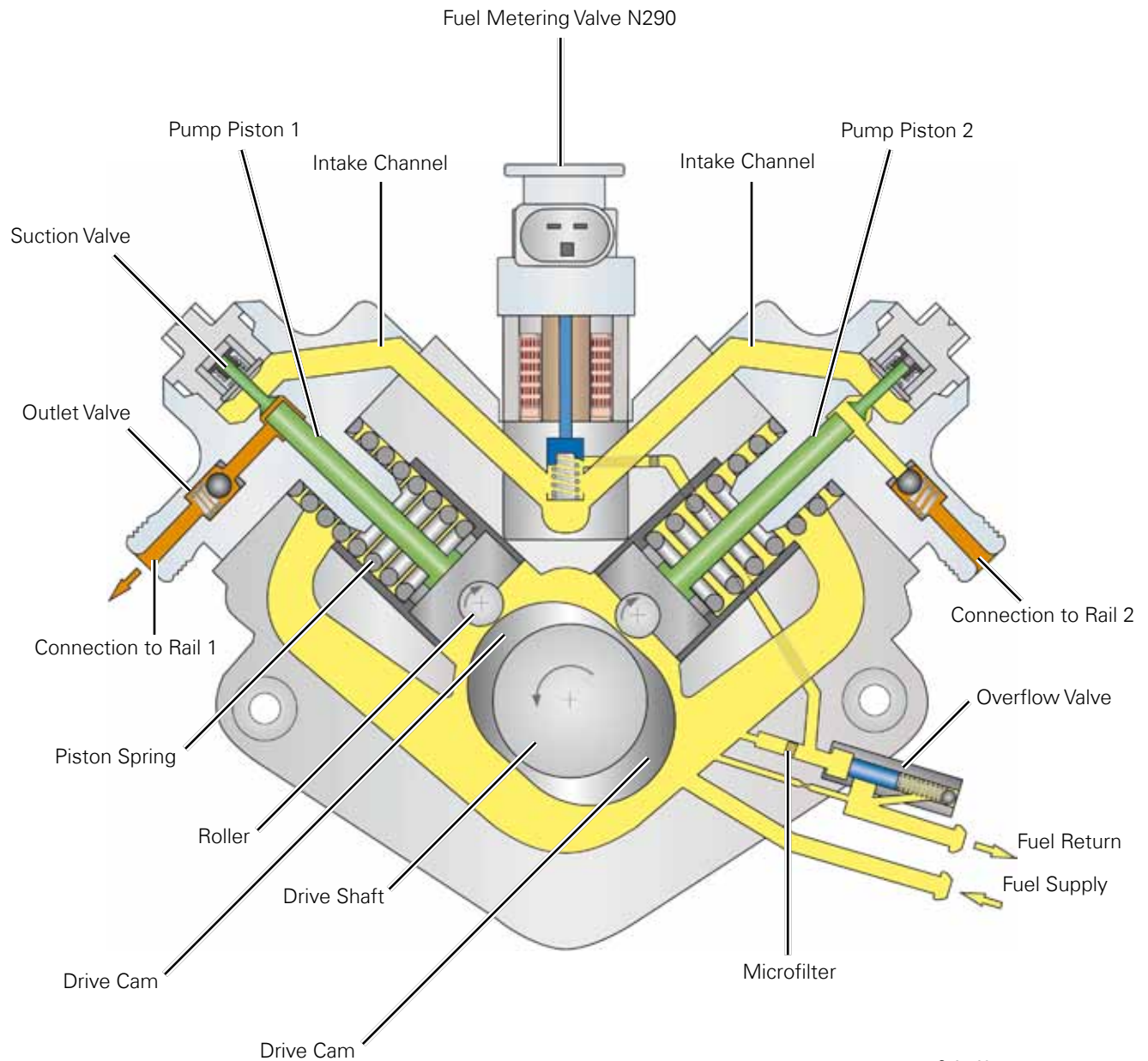

Engine Mechanics

High-Pressure Fuel System

Fuel Metering Valve N290

The fuel metering valve is part of the high-pressure pump and regulates the fuel quantity required to generate high pressure. The high-pressure pump only has to generate the pressure necessary for the current operating situation. This reduces power consumption and unnecessary fuel heating.

How it Works

When no current is supplied, the fuel metering valve is open. The valve is actuated by the ECM with a Pulse-Width-Modulated signal (PWM) signal to reduce the supply quantity to the compression chamber.

The fuel metering valve is pulsed closed by the PWM signal. Depending on the PWM frequency, the position of the control piston moves. This controls the fuel supply quantity in the compression chamber of the respective pump piston 1 or 2.

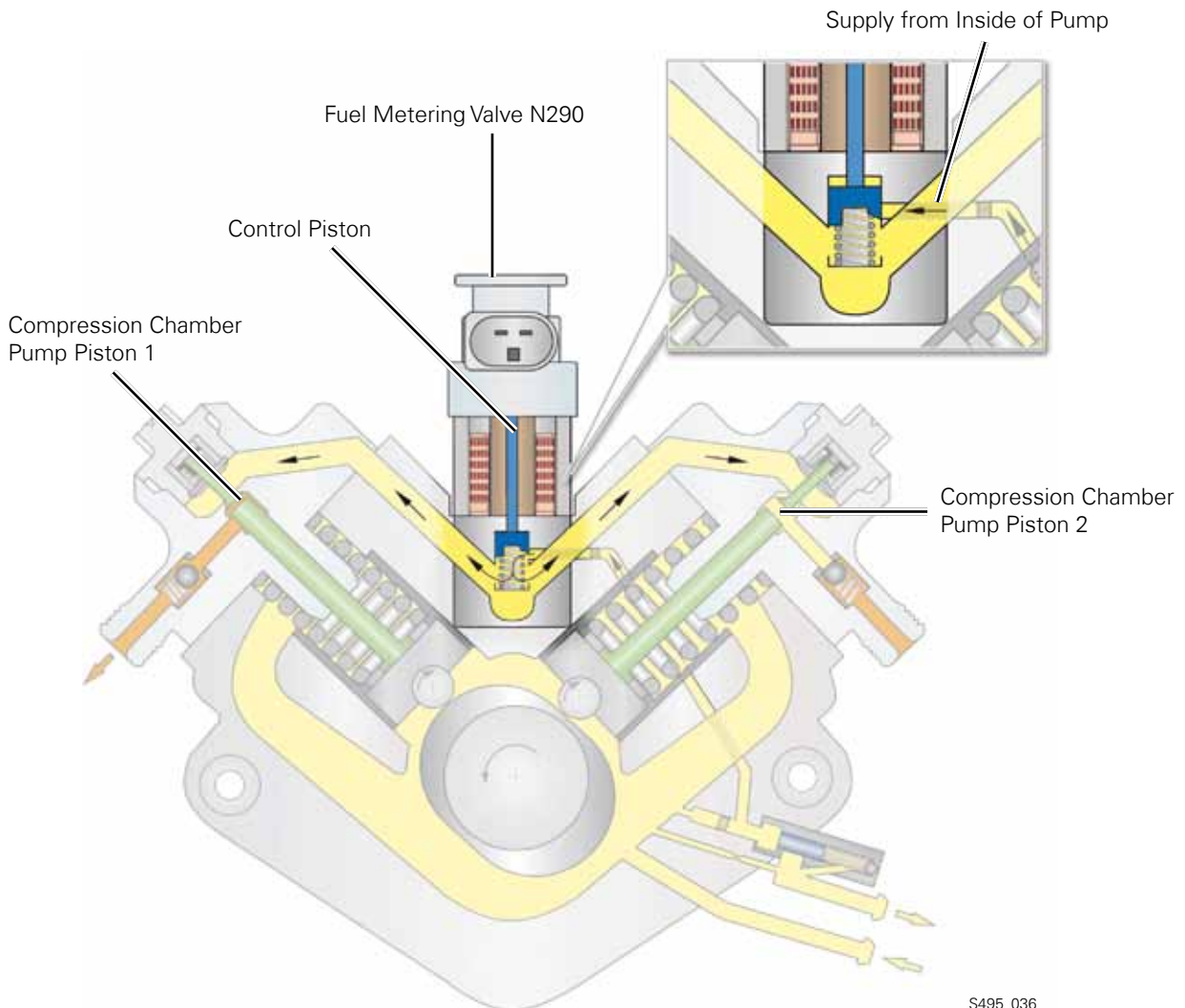

S495_036

Overflow Valve

The fuel pressure in the low-pressure area of the high-pressure pump is regulated by the overflow valve.

How it Works

The Transfer Fuel Pump G6 delivers fuel from the fuel tank to the high-pressure pump at a pressure of approx. 5 bar (72.5 psi).

The overflow valve regulates the fuel pressure in the high-pressure pump to approx. 4.3 bar (62 psi).

The fuel delivered by the Transfer Fuel Pump G6 works against the piston and the piston spring of the overflow valve. When the fuel pressure rises above 4.3 bar, the overflow valve opens and opens up the path for return of the fuel. The excess fuel flows to the fuel tank through the fuel return line.

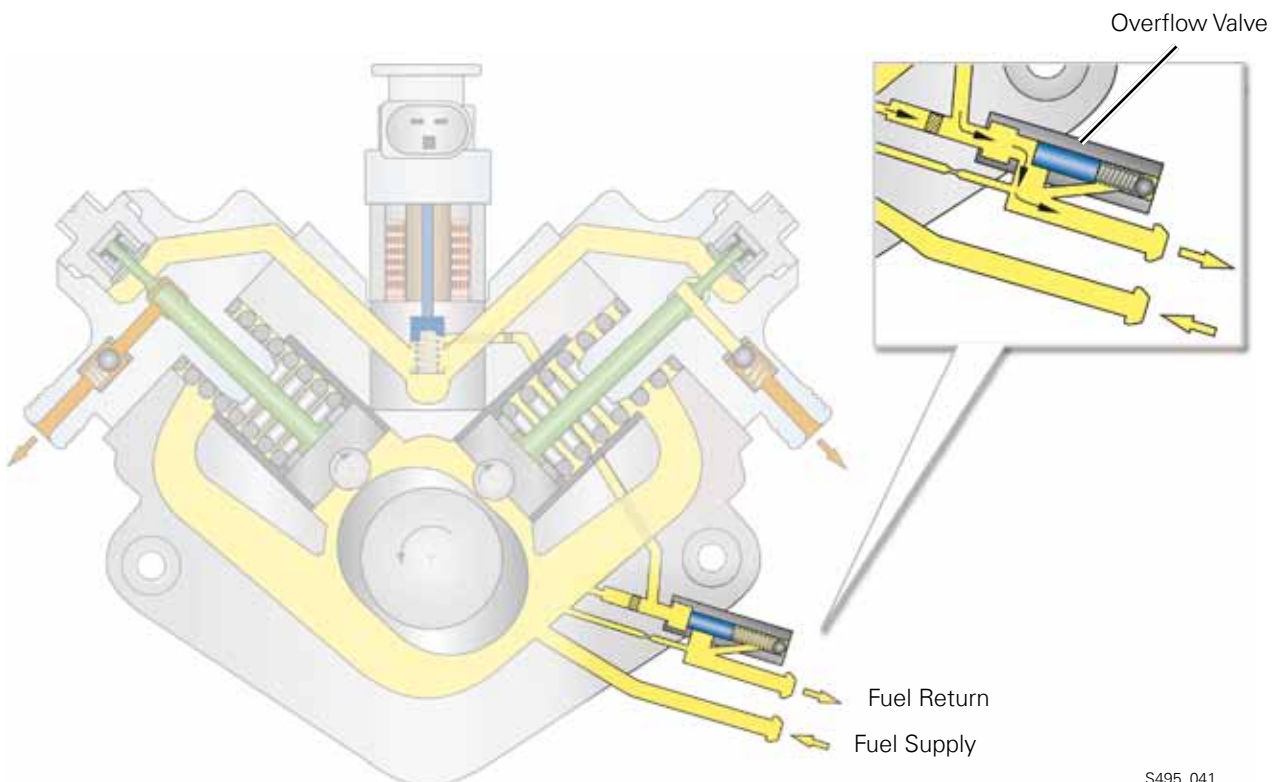

S495_041

Service

High-pressure Generation

Suction Stroke

The downward motion of the pump piston increases the volume of the compression chamber. As a result, the pressure of the fuel in the high-pressure pump and the pressure in the compression chamber differ. The suction valve opens and fuel flows into the compression chamber.

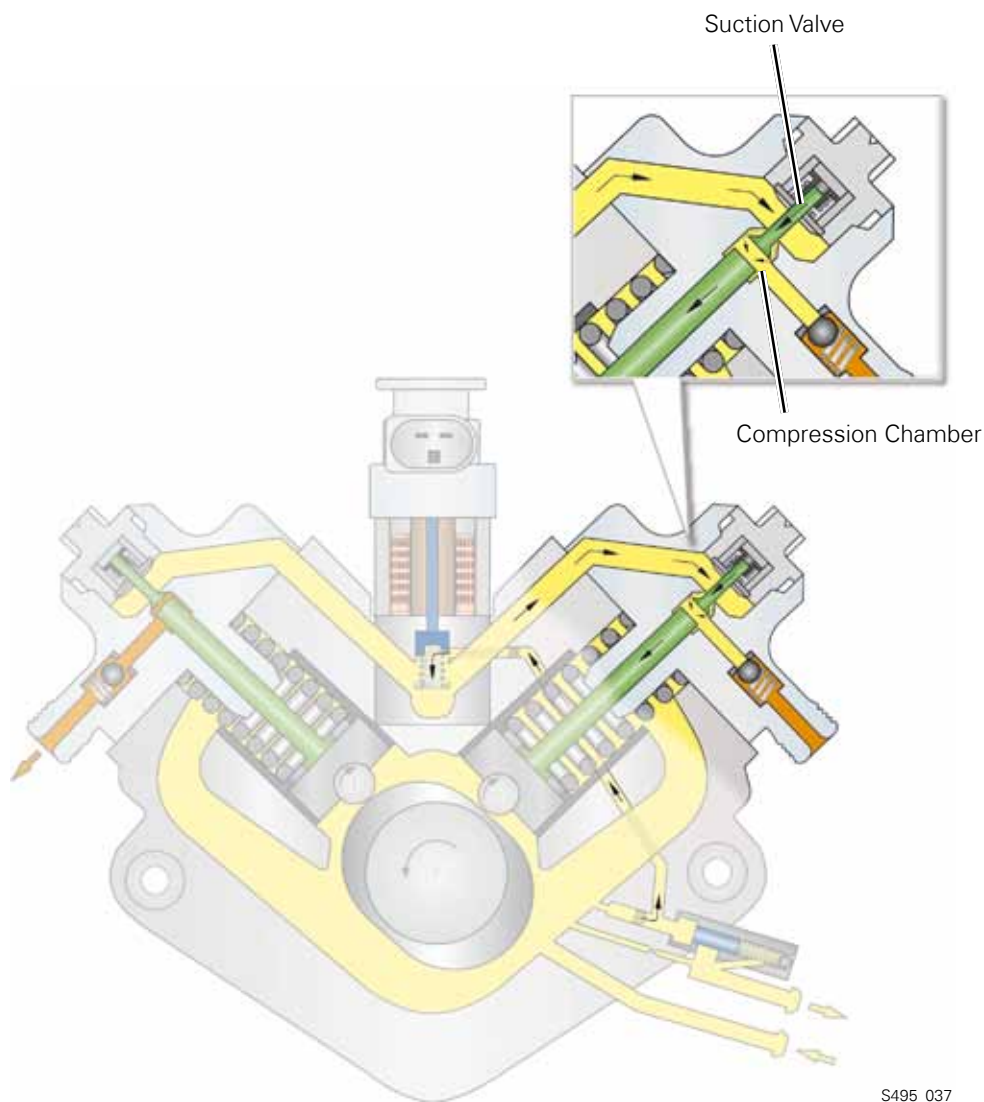

S495_037

Delivery Stroke

Once one of the pump pistons starts to move upward, the pressure in the corresponding compression chamber rises and the suction valve closes. As soon as the fuel pressure in the compression chamber rises above the pressure in the high-pressure area, the outlet valve (non-return valve) opens and fuel is delivered to the high-pressure accumulator (rail).

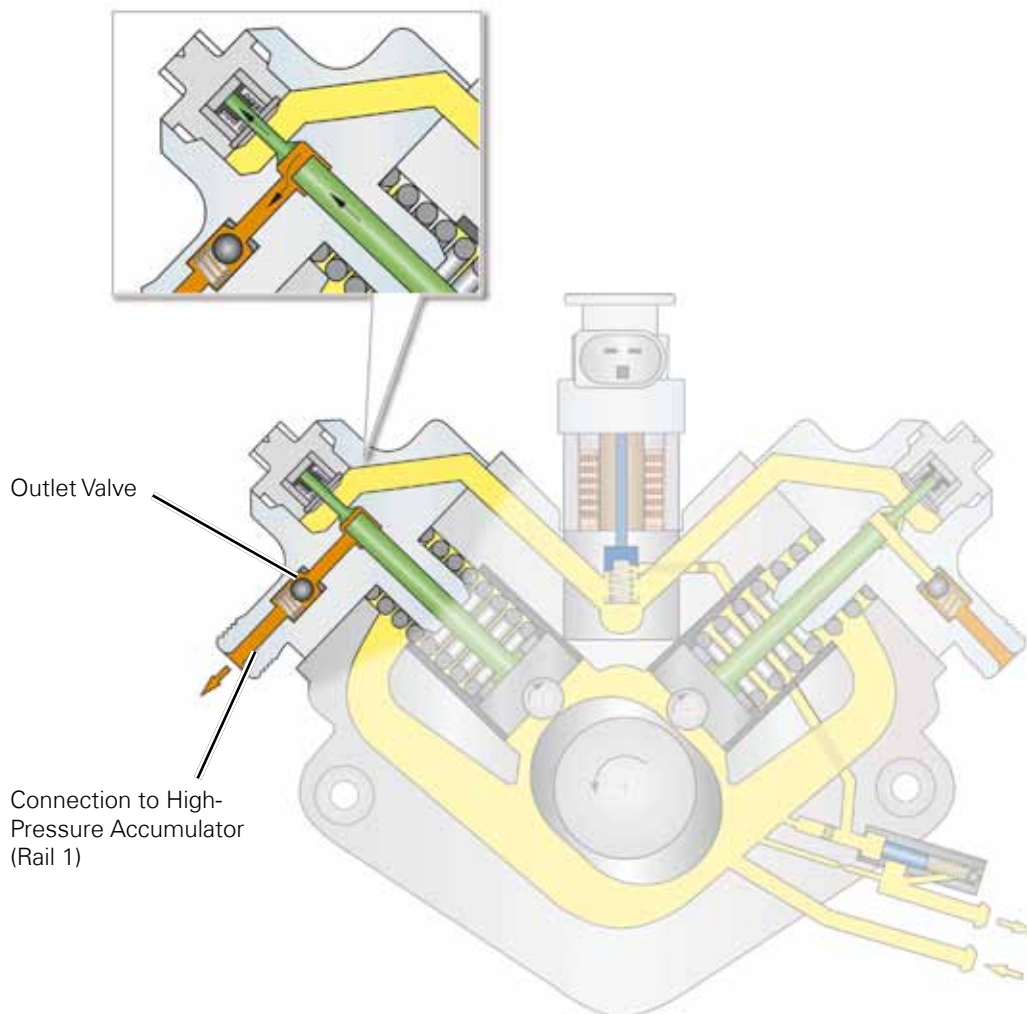

S495_038

Engine Management

System Overview

Sensors

Mass Airflow Sensor G70

Engine Speed Sensor G28

Camshaft Position Sensor G40

Engine Coolant Temperature Sensor G62

Engine Coolant Temperature Sensor on Radiator Outlet G83

Fuel Temperature Sensor G81

Engine Temperature Control Sensor G694

Oil Level Thermal Sensor G266

Fuel Pressure Sensor G247

Accelerator Pedal Position Sensor G79

Accelerator Pedal Position Sensor 2 G185

Exhaust Gas Recirculation Potentiometer G212

Brake Light Switch F

Charge Air Pressure Sensor G31 and Intake Air Temperature Sensor G42

Heated Oxygen Sensor G39

Oil Temperature Sensor 2 G664

Oil Pressure Switch F22

Reduced Oil Pressure Switch F378

Exhaust Gas Temperature Sensor 3 (after Catalytic Converter) G495

Exhaust Gas Recirculation Temperature Sensor G98

Exhaust Gas Temperature Sensor 1 G235

Exhaust Gas Temperature Sensor 4 (after Particle Filter) G648

Pressure Differential Sensor G505

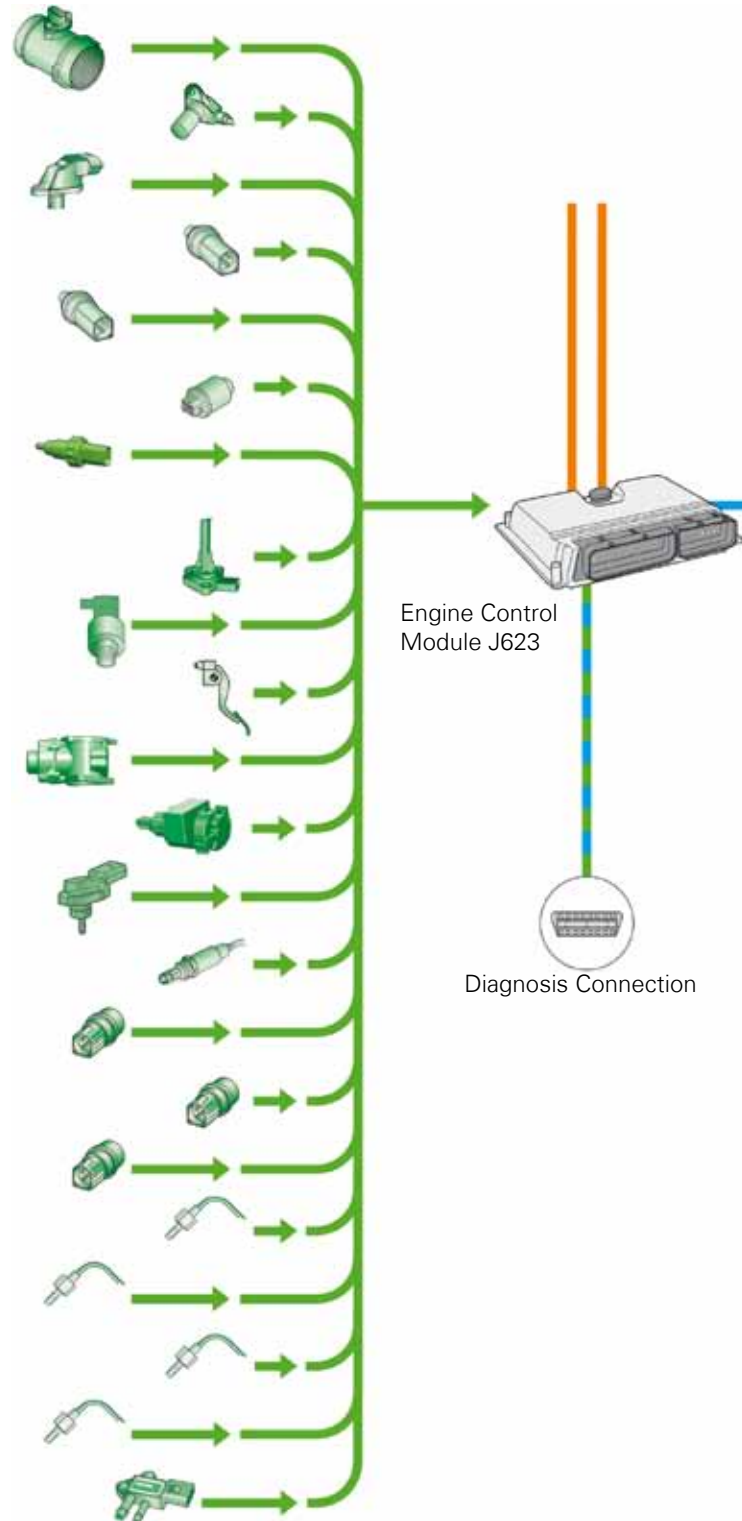

Engine Management

Actuators

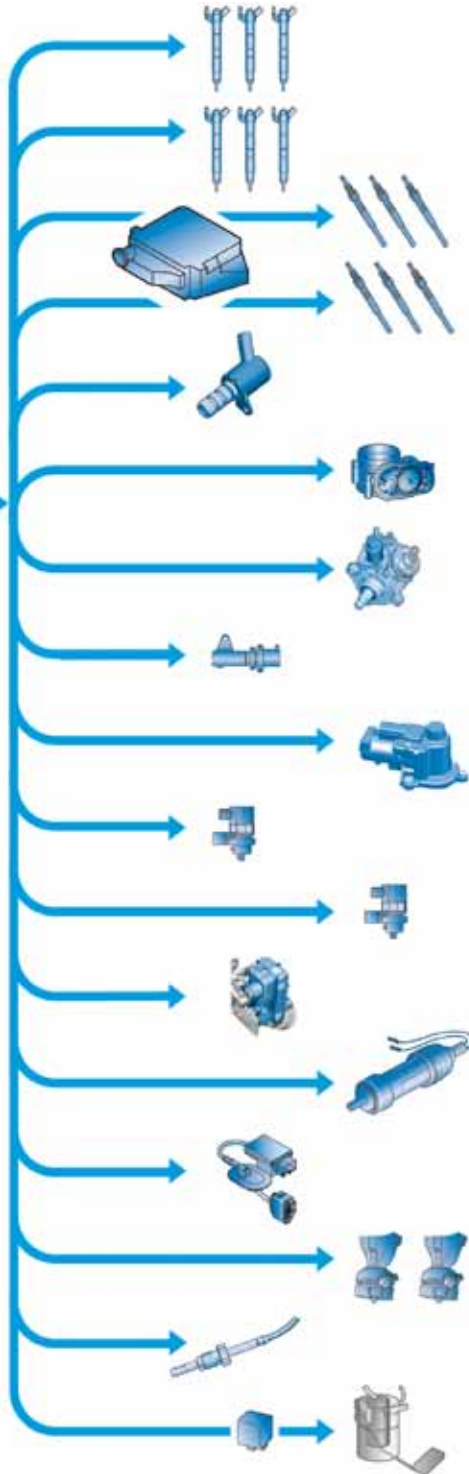

Injectors, Cylinders 1 - 3
N30, N31, N32

Injectors, Cylinders 4 - 6
N33, N83, N84

Automatic Glow Time Control Module J179
Glow plugs 1 - 3
Q10, Q11, Q12

Glow plugs 4 - 6
Q13, Q14, Q15

Oil Pressure Regulation Valve N428

Throttle Valve Control Module J338

Fuel Metering Valve N290

Fuel Pressure Regulator Valve N276

Exhaust Gas Recirculation Motor V338

Exhaust Gas Recirculation Cooler Changeover Valve N345

Cylinder Head Coolant Valve N489

Turbocharger Control Module 1 J724

Map-controlled Engine Cooling Thermostat F265

Fuel Pump Control Module J538

(Left, right) Electrohydraulic Engine Mount Solenoid Valves
N144, N145



Oxygen Sensor Heater Z19



Fuel Pump Relay J17
Transfer Fuel Pump G6

S495_046

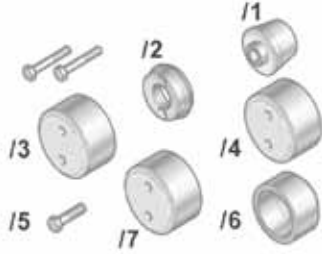
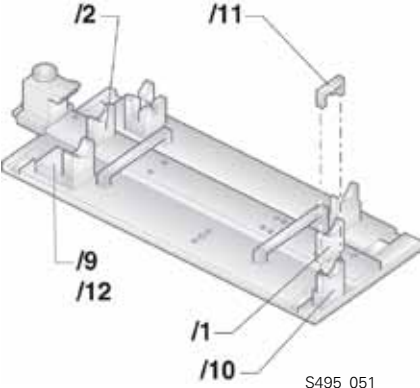
Service

Special Tools

Designation	Tool	Application
T40048	 <p style="text-align: right;">S495_059</p>	Assembly Tool for Crankshaft Seal
T40094 T40094/1 T40094/2 T40094/9 T40094/10 T40094/11 T40094/12	 <p style="text-align: right;">S495_051</p>	Camshaft Removal and Fitting Tool
T40096	 <p style="text-align: right;">S495_053</p>	Camshaft Fitting Tool
T40245	 <p style="text-align: right;">S495_057</p>	Locking Pin for Chain Sprocket

Designation	Tool	Application
T40246	 <p>S495_058</p>	Bracket for Securing Chain Tensioner
T40248	 <p>S495_060</p>	Counterhold Tool for High-pressure Pump
VAS 5161	 <p>S495_056</p>	Removal and Installation Device for Valve Cotters

Important Links



https://www.datarunners.net/vw_crc/default.asp?pageid=home



www.vwwebservice.com



www.vwhub.com

Knowledge Assessment

An on-line Knowledge Assessment (exam) is available for this Self-Study Program.

The Knowledge Assessment may or may not be required for Certification.

You can find this Knowledge Assessment at:

www.vwwebservice.com

For Assistance, please call:

Volkswagen Academy

Certification Program Headquarters

1-877-791-4838

(8:00 a.m. to 8:00 p.m. EST)

Or, E-mail:

concierge@volkswagenacademy.com



Volkswagen Group of America
2200 Ferdinand Porsche Drive
Herndon, VA 20171
February 2013

