

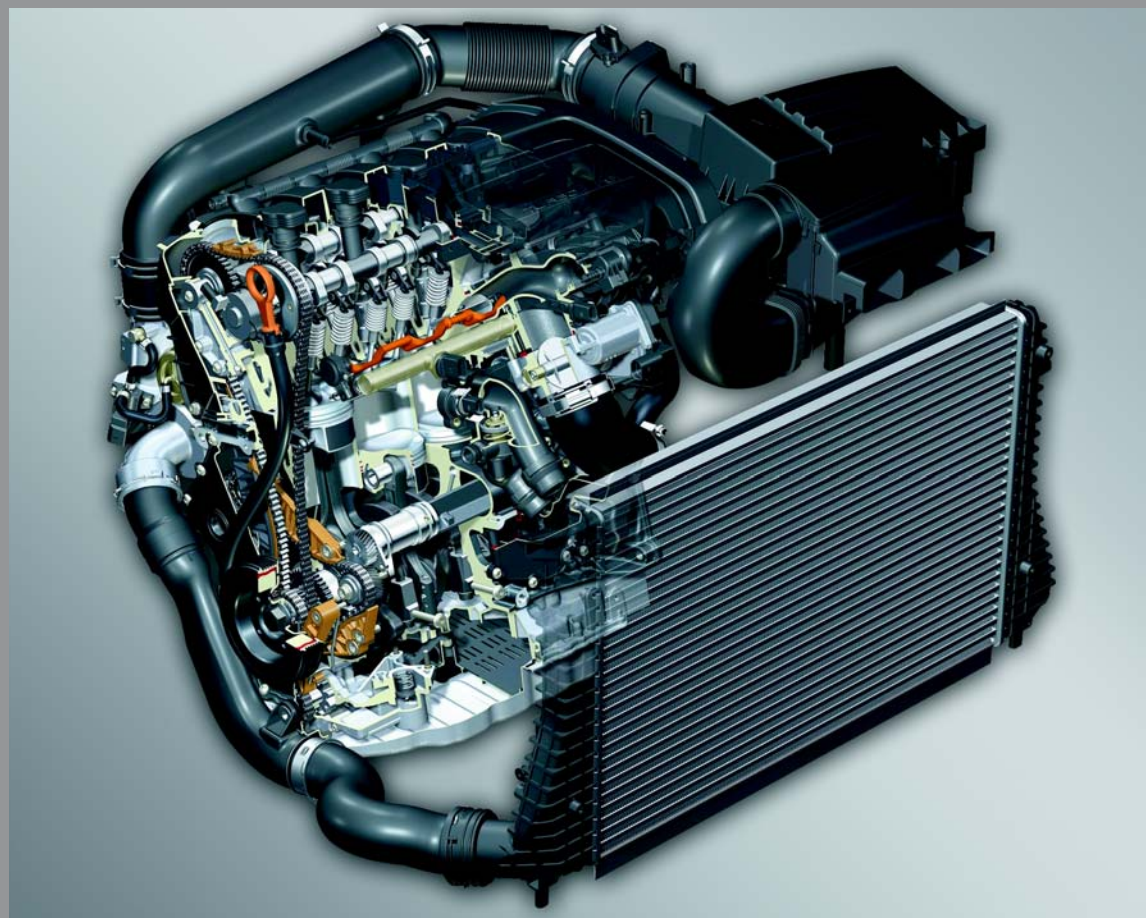

Self Study Programme 401

1.8 l TFSI 16v 118kW engine

Architecture and Operation



A new family of engines has been developed, the EA 888 family, which will progressively replace the EA 113 family engines and the direct petrol injection engines (MPI).

This new generation of engines (EA888) starts with an overboosted direct petrol injection and 1800 c.c. capacity engine.

This engine has been designed taking into account the constant evolution of technology in order to achieve maximum performance and at the same time to make the most out of each and every single drop of fuel.

During the process of design and development of the engine the following issues were set as priorities:

- To achieve a reasonable price for the customer by reducing the unitary cost of manufacturing,
- To provide for both longitudinal and transversal assembly of the engine into the different models of the Group,
- To comply with legal requirements such as pedestrian protection or reduction of the footwell area deformation zone in front collisions,
- To comply with the environmental standards regarding noise and exhaust gases,
- To obtain a good mechanical and thermodynamics performance in a compact structure,
- To contribute to ease of repair and maintenance at the Aftersales Service.



S401_001

The Self-Study Programme includes basics regarding the design and operation of new engines, new engine components and new technologies.

The Self-Study Programme is NOT a repair manual. For maintenance and repair jobs it is absolutely necessary to refer to the updated technical literature of each of the Brands.



Additional
information

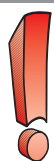

Note

Summary of contents

Mechanicals	4
Air passage	20
Lubrication system	28
Cooling system	30
Fuel supply system	33
Synoptic chart	36
Sensors and actuators	38
Variable Timing	44
Functions wiring diagram	46
Glossary	48
Check your knowledge	50

Mechanicals

Technical features

The 1.8l TFSI engine with 4 cylinders inline and 4 valves per cylinder has been designed to run always on homogeneous mix. The engine works in a very similar way to the 2.0l TFSI engine. However, design and posi-

tion of most of the engine components have been modified in order to achieve a more compact engine and to reduce maintenance.

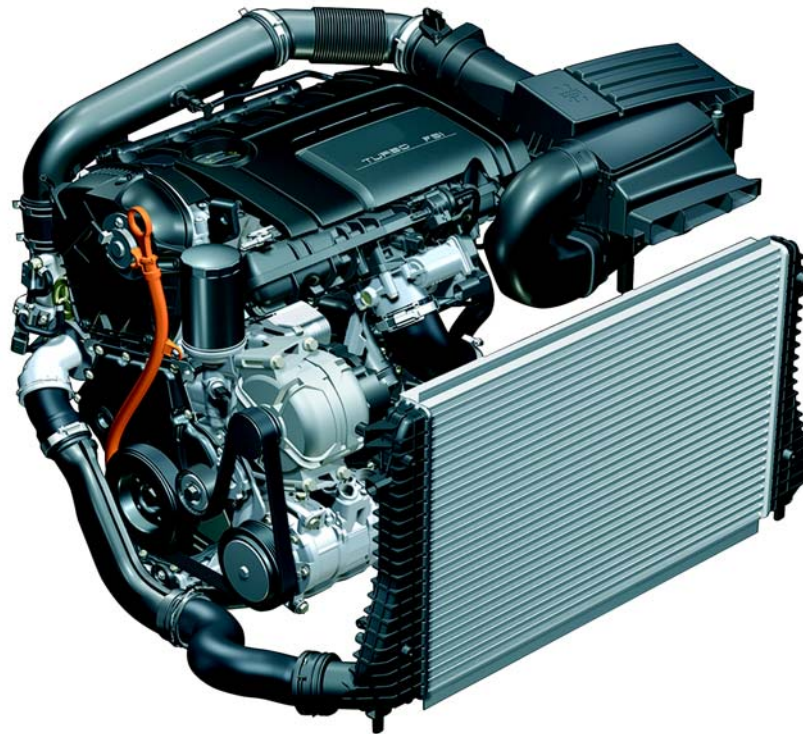

S401_002

- 1 It is ready for complying with the EU 5 emissions standard. However, in the meantime, until it becomes mandatory, the engines marketed will comply with the EU 4 emissions standard.
- 1 The camshafts, balance shafts and oil pump are driven by means of three chains.
- 1 The counter-rotating balance shafts are integrated in the engine block, above the crankshaft.
- 1 It is fitted with variable timing in the intake camshaft
- 1 The inlet manifold is equipped with the guided intake system.
- 1 Fuel supply system made up by lo pressure circuit and a high pressure circuit, with no return passage and with multiple drills injectors.
- 1 The turbocharger, integrated in the exhaust manifold, if fitted with overboost pressure regulation and air recirculation when decelerating.
- 1 Exhaust system with precatalyst close to the engine, and only one lambda probe.
- 1 New coolant pump module, driven by a belt.
- 1 Oil filter position on the top of the engine, screwed onto the auxiliary elements support bracket.
- 1 It incorporates an oil and fuel vapours elimination (blow-by) vapours system



For further information about the engine components and operation consult the information in each of the Brands the for the 2.0l TFSI engine.

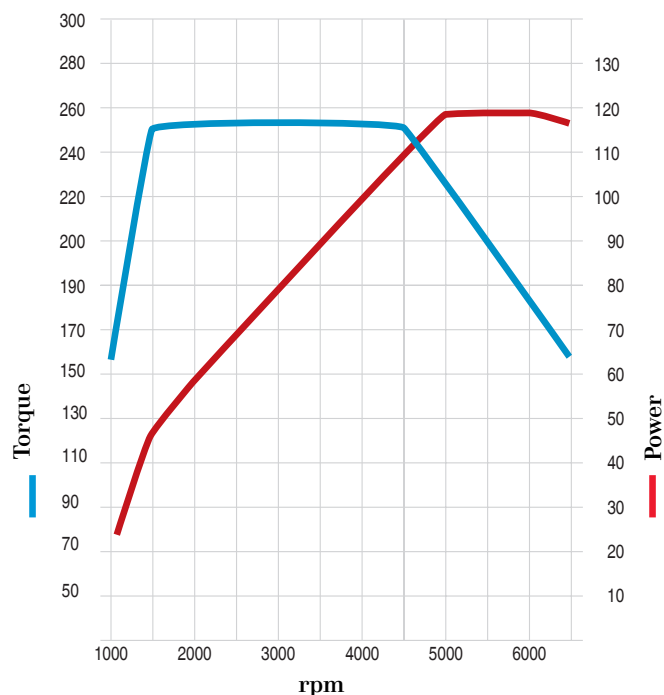

S401_003

Technical data

This engine's designation letters are BYT. However, because of its evolution, this engine will be subject to some changes that will imply having to change the designation letters to BZB.

The 1.8l TFSI engine delivers high power at high revs, with a maximum power output of 160 bhp from 5000 rpm and practically up to the injection cut-off moment.

It also delivers high and constant engine torque along a wide range of revs. This is so mainly because of using an intake variable timing system which provides complete combustion chamber fill-up, thus reaching a maximum torque of 250 Nm from 1500 to 4200 rpm.

Other achievements are an economical consumption rate, engine spontaneity and elasticity plus driving comfort.

Engine designation letters	BYT - BZB
Capacity [cm³]	1,798
Bore [mm]	82.5
Stroke [mm]	84.2
Compression ratio	9.6:1
Maximum power	118 kW at 5,000 - 6,200 rpm
Maximum torque	250 Nm at 1,500-4,200 rpm
Engine management system	Bosch Motronic MED 17.5
Firing order	1-3-4-2
Fuel	Unleaded 98 - 95 octane (it is possible to use 91 octane rating, however accepting a loss of power output).
Emission standards	EU 4

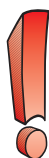

For the sake of understanding the document better, all explanations are based on the BYT engine and any modifications worth mentioning which affect the BZB engine will be indicated.

Engine block

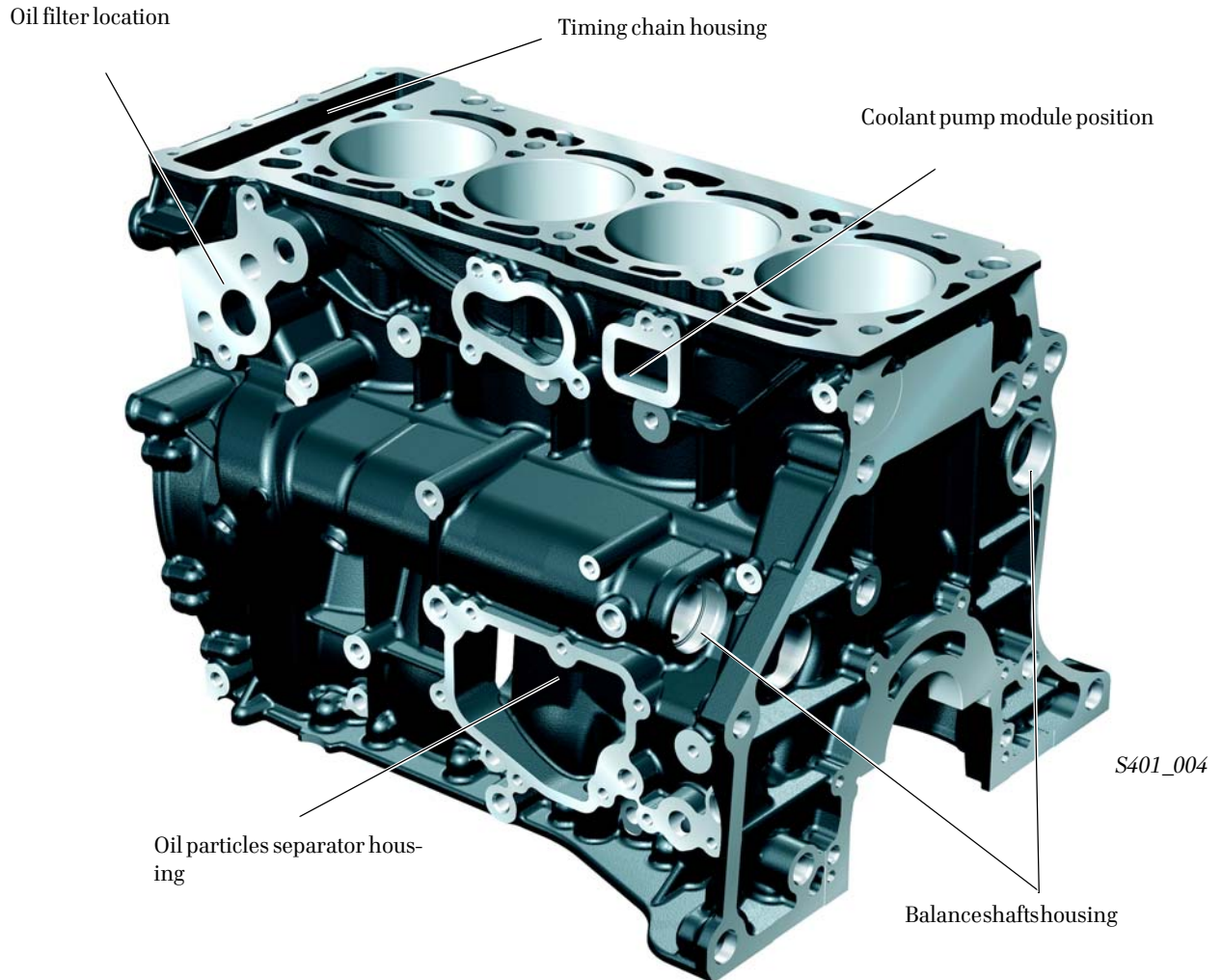

The engine block, made of grey cast steel was built using the “closed-deck”, technique, which was already used in the previous FSI engines. Such a technique implies casting the cylinder sleeves firmly onto the block, thus ensuring quality and long life.

Then, the surface of the cylinders is polished by using a three stage pressurised fluid flow. This technique allows reducing the engine run-in period as well as oil consumption.

Compared to the 2.0l TFSI engine, it only shares the use of oil injectors for cooling the pistons as well as reduced distance between the cylinders (88 mm),

which leaves open the possibility of transversal or longitudinal assembly in the vehicles.

Otherwise, the engine block is completely different:

- The counter-rotating balance shafts are integrated in the engine block, just above the crankshaft,
- The coolant pump is not housed in the engine block,
- The timing chain is integrated in the side of the block,
- The oil filter is accessed from the top of the engine,
- The intake side houses a thick oil particles separator.

Engine block

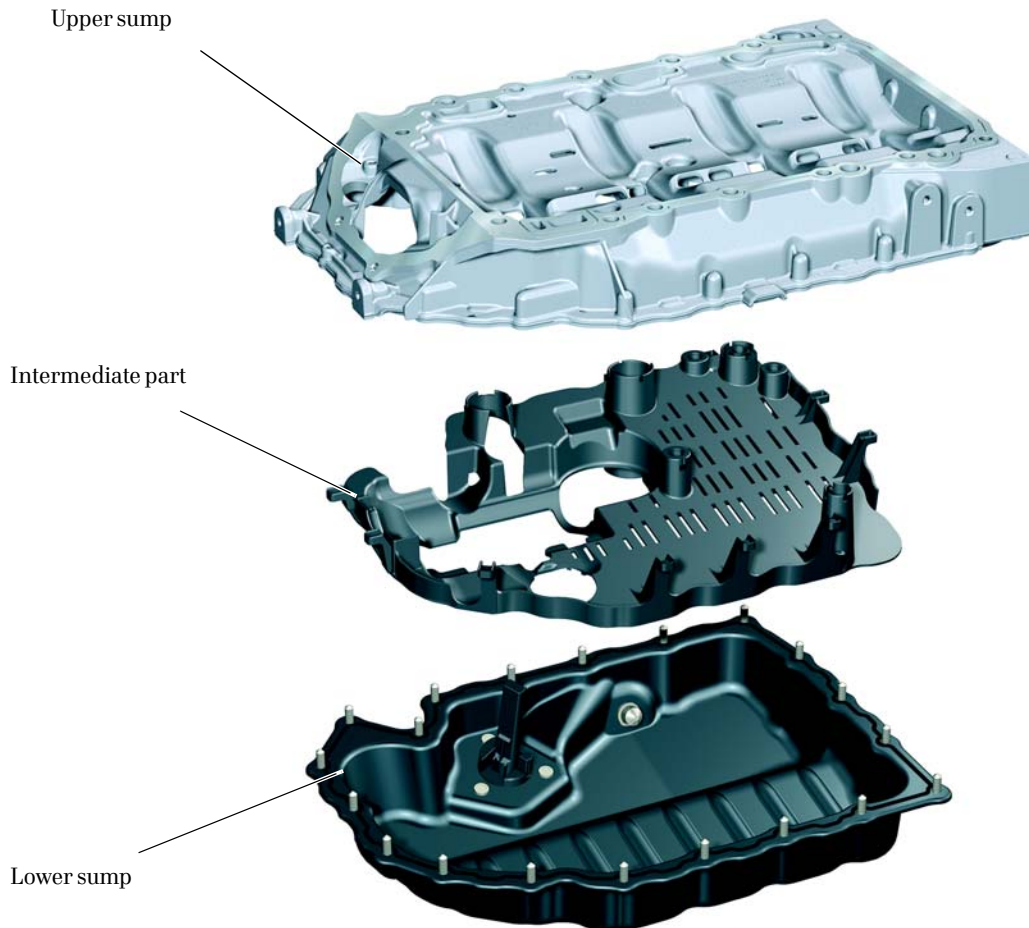

S401_005

The sump has been designed in the most compact possible way, thus reducing the height of the engine. This has been possible, partly because of moving the balance shafts towards the engine block. The sump is made of three parts:

- The upper sump, made of aluminium alloy and bolted to the engine block, serves the purpose of additional reinforcing to the block and holds the oil pump. Sealing has been achieved by using a liquid sealant on the joint with engine block. To remove the upper sump the flywheel must be replaced in the first place and access two side screws,
- The intermediate part, made of polyamid plastic, which is screwed to the upper sump is used for preventing foam building up in the sump,
- The lower sump is made of steel plate. It is screwed onto the upper sump with a liquid sealant to seal it off. It stores oil and has an oil release plug.

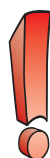

Engines equipped with the LongLife system incorporate the oil temperature and level sensor G266 in the lower sump.

Mechanicals

Crankshaft

The crankshaft is made of induction tempered steel. It has five supports and eight counterweights for optimum internal compensation.

To improve the engine block's reinforcement the three central shells of the engine have been screwed sideways onto the block as well as vertically.

The five lower half-shells of the crankshaft have a lubrication slot and can be replaced by other thicker ones for radial adjusting of the crankshaft. The axial play adjusting is corrected by using the axial half-shells placed on the central mounting of the engine.

Conrods

The conrods, like the ones used in the 2.0l TFSI engine are drilled for lubrication of the gudgeon pin and manufactured by using the fracture technique. d) The conrod big end is trapezoidal, to share out the forces better,

and the sleeve is made of bronze.

The upper and lower half-shells are made of different materials, the upper one is darker and made of a more resistant material in order to withstand greater efforts.

Piston

Like in the 2.0l TFSI engine, a support fitting is introduced for the upper piston ring. Also, the light structure concept for the piston skirt is maintained as well as the graphite layer, which provides enhanced durability, improved movement smoothness and reduced power loss due to friction.

The new piston surface design contributes to achieving an optimum homogeneous mix.

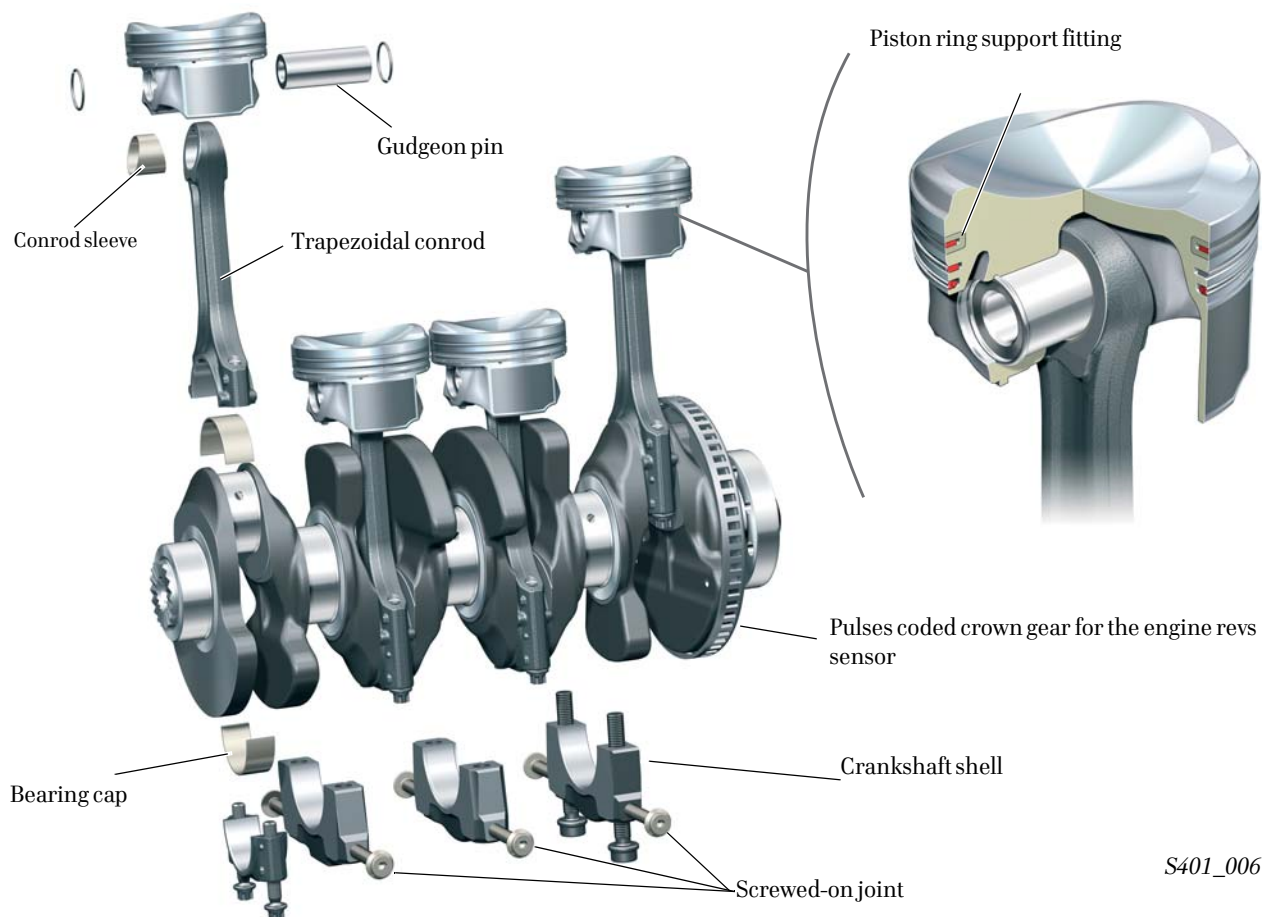

S401_006

Toothed gears module

The transmission of force from the crankshaft to the different timing chains is done by means of a toothed gears module.

The crankshaft bolt is responsible for maintaining the Poly-V belt and the crankshaft toothed gears module linked, so that the three components rotate as a single assembly.

Also, side teeth have been machined on the three components in order to increase the contact surface between them and transmit a greater amount of rotation force with a smaller diameter of the components.

The side teeth on the end of the crankshaft provides greater torque transmission to the timing.

On each of the side toothed areas a wider teeth has been machined so that there is only a single assembly position for all three elements.

The three teathed gears of the module drive the balance shafts, the camshafts and the oil pump, by using three chains.

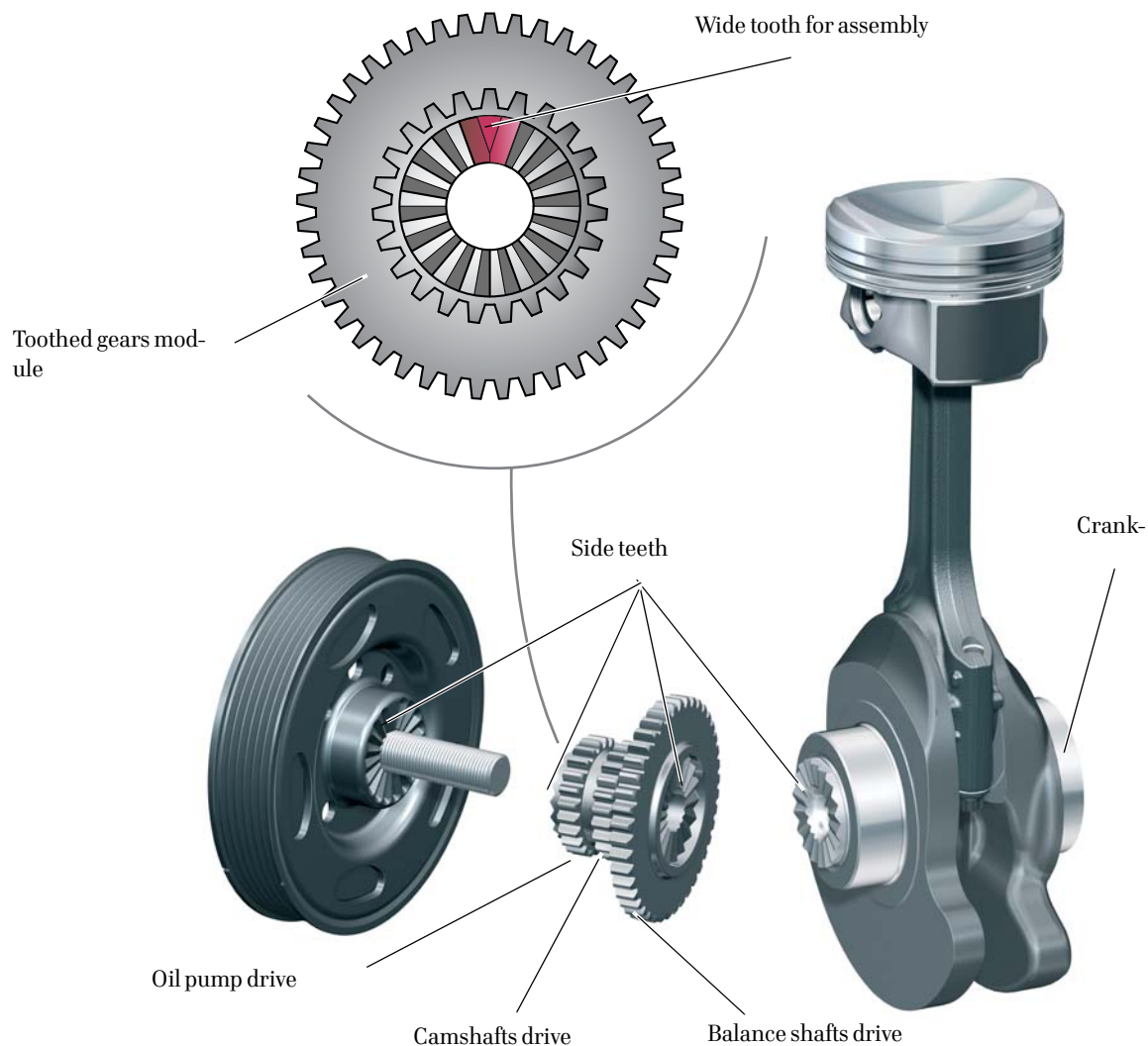

S401_007

Mechanicals

Cylinder head

The cross-flow cylinder head is made of aluminium alloy and includes the following components:

- A non-return valve for the oil,
- Each inlet passage is divided into two halves, an upper section and a lower section, by means of a tumble plate,
- On the exhaust side there is a support guide for the exhaust manifold,
- The eight intake and eight exhaust valves are chromed and their seats are BLINDADO. The exhaust valves are filled with sodium,
- The valves are activated with the smooth valves operation technique,
- The exhaust camshaft has a toothed gear on one end and on the other end it is fitted with a quadruple cam for driving the fuel high pressure pump,
- The inlet shaft has a variator and a toothed crown gear on the centre of the shaft for the Hall sensor G40,
- The area of contact with the engine block is fitted with a three-layer metal cylinder head gasket. There are two types of gaskets, one for the BYT engine and one for the BZB engine.

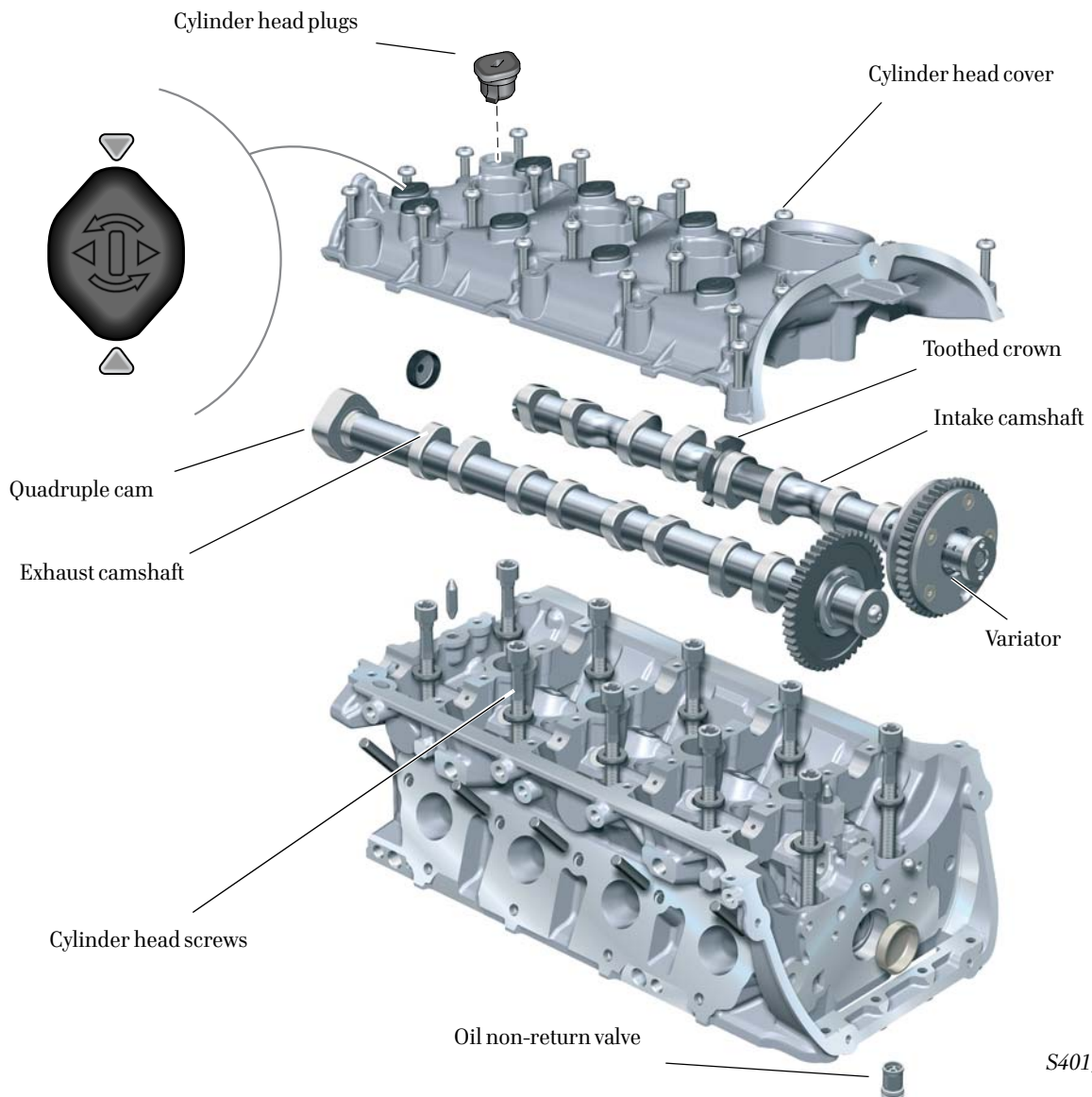

S401_008

Cylinder head cover

The cylinder head cover, made of aluminium alloy, is bolted onto the cylinder head and sealed off with a liquid sealant. Its main function is to hold the camshafts and reinforce the cylinder head.

Accessing the cylinder head bolts implies removing in the first place the blow-by vapours separator module, which is screwed onto the cylinder head cover, and some plastic plugs. It is not necessary to remove the cyl-

inder head cover to separate the cylinder head from the engine block.

The cylinder head cover suffers some alterations for the BZB engine. However, both the material used and the way of attaching, the sealing and the function of the cylinder head cover continue to be the same. These changes made on the engine have displaced the oil return passage to the sump over to the centre of the cylinder head cover.

BYT engine cylinder head cover

Orificio de entrada de aire para la ventilación forzada del bloque.

Ubicación del transmisor Hall G40

Orificio de llenado de aceite

Conducto de retorno de aceite hacia el cárter.

Tapones de acceso a los tornillos de culata.

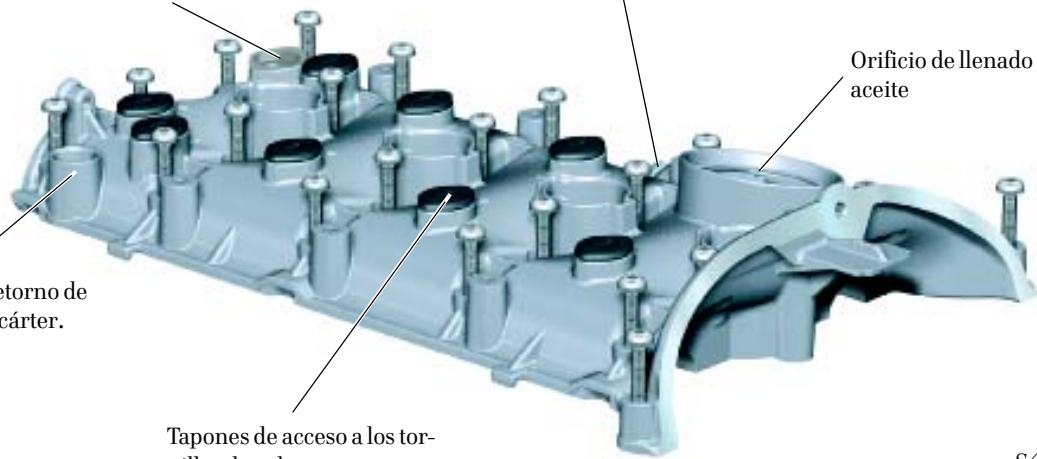

S401_009

Tapa de culata del motor BZB

Tapones roscados de acceso a los tornillos de culata.

Conducto de subida de vapores del cárter

Tapones de acceso a los tornillos de culata.

Conducto de retorno de aceite hacia el cárter.

Ubicación del módulo separador de los vapores de aceite.

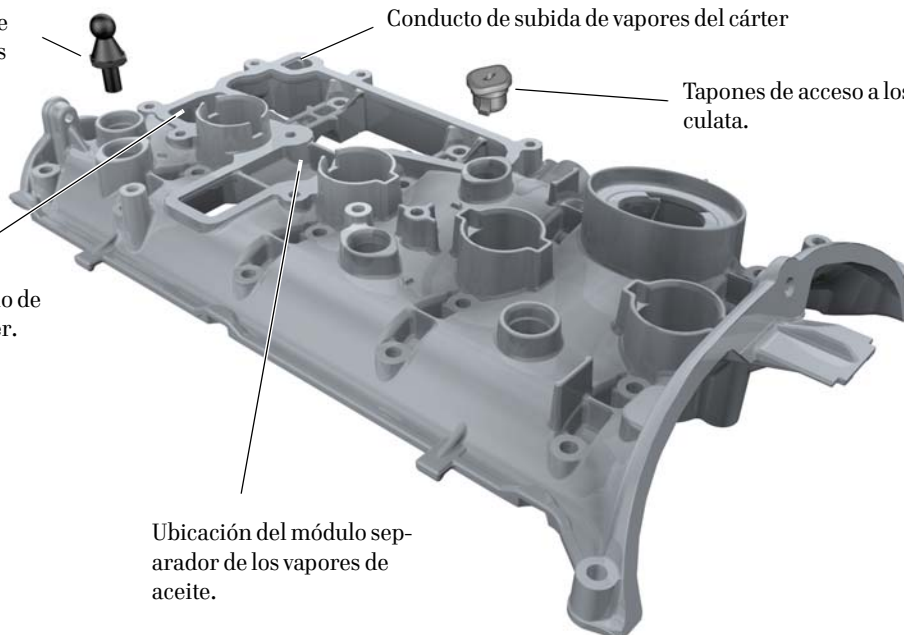

S401_010

Mechanicals

Side cover

The cylinder head, made of polyamid plastic, closes the cylinder head on the side and seals the area where the timing chain is housed by means of a rubber seal.

The new diagonal shaped design of the bonding surface between the cylinder head and the side cover make it easier to take out and insert the chain. It also prevents oil splashing, generated by the moving timing compo-

nents, directly against the seal and thus reducing the chances of oil leaks.

To remove the cylinder head you first need to remove the side cover. This is how you can access two cylinder head screws and four screws that hold the cylinder head timing side to the engine block.

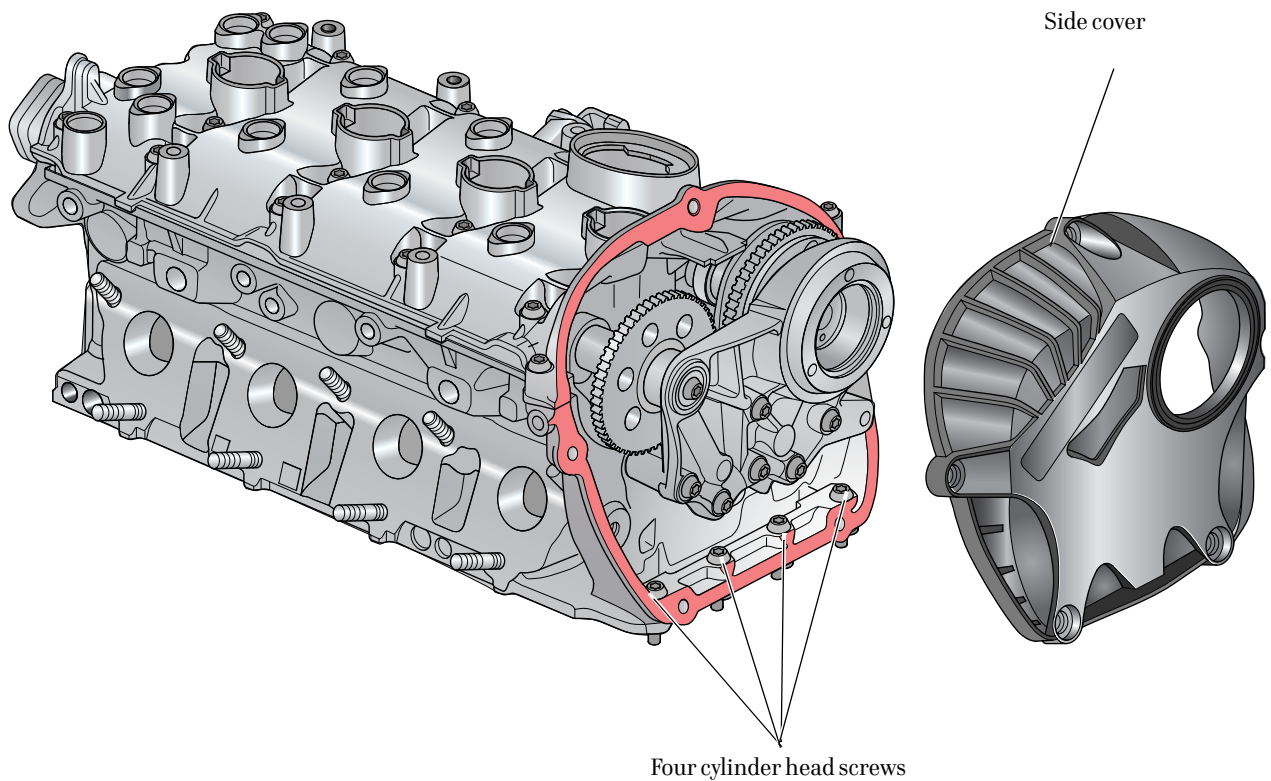

S401_011

Oil distributor mounting

The mounting is made of a pressure moulded aluminium alloy, and it is screwed onto the cylinder head. As well as holding the camshafts in place, it is responsible for supplying pressurised oil to the camshaft bearings and to the inlet shaft variator.

The mounting has a sieve for filtering the oil coming from the cylinder head, thus preventing dirt particles reaching the variator.

The variable timing solenoid valve, N205, is screwed to the mounting by three screws, in a single assembly position.

To remove the distributor mounting you first need to remove the solenoid valve and the distributor valve.

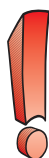
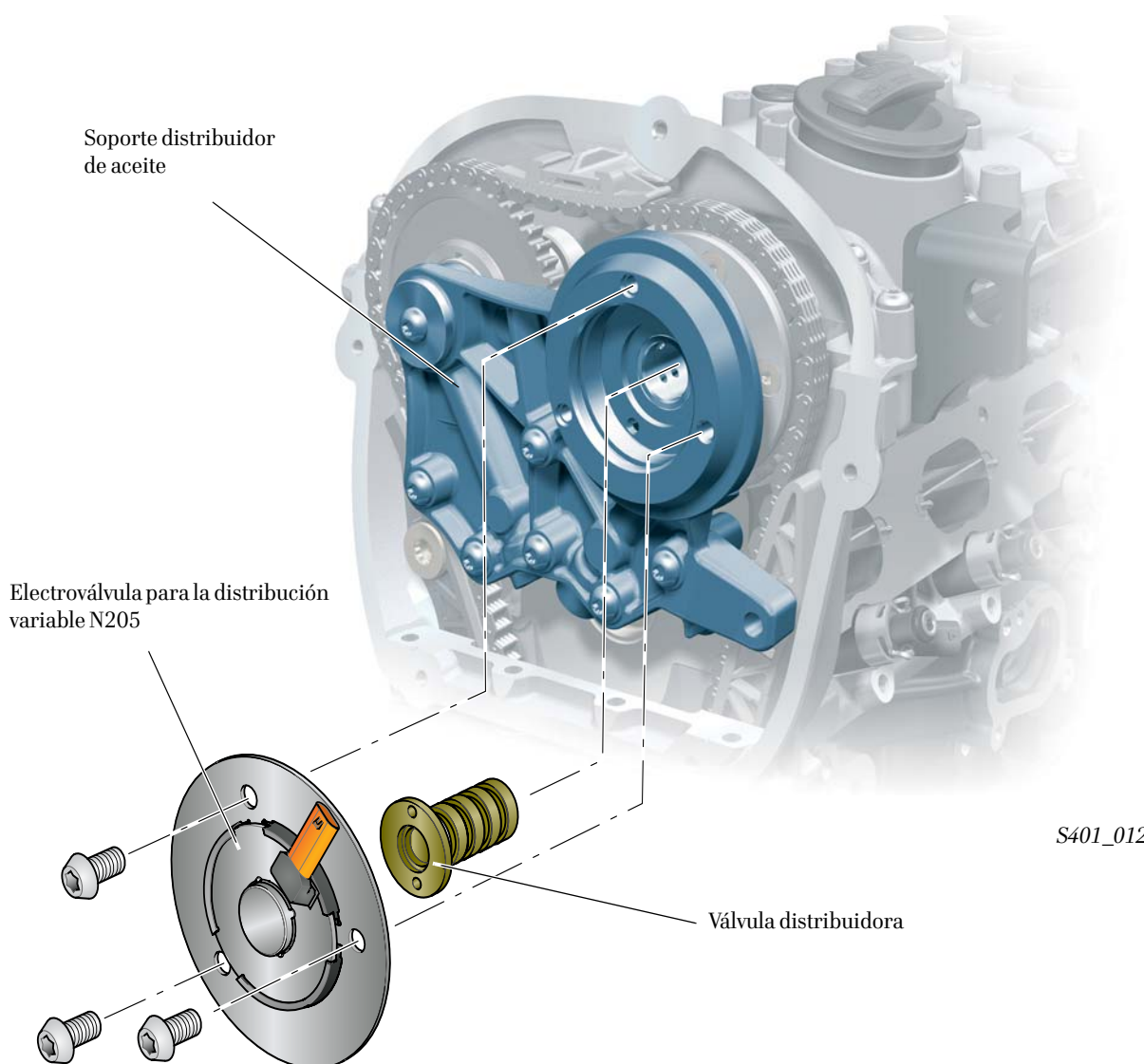

The distributor valve is screwed-on anti clockwise. To remove it you need to use the special tool T10352.

Mechanicals

Timing

The timing is made up by three chains driven by the crankshaft toothed gears module:

- One chain for driving the camshafts. The existing down gearing drives the camshafts at half the rotation speed of the crankshaft,
- One chain for driving the balance shafts. The existing down gearing drives the balance shafts at twice the rotation speed of the crankshaft,
- One chain for driving the oil pump.

The chains used are of new design, metallic and maintenance free. The operation principle is very similar to the one used for driving the conventional type of belts.

Also, these chains are more noiseless, have a much higher performance and greater flexibility than the chains being used up to now. They also transfer the same amount of torque with a thinner chain.

For optimum guiding and tension of the chains several polyamid plastic guides and three tensioners have been used:

- An hydraulic tensioner for driving the camshafts. To remove it you need to lock the tensioner piston by using special tool T40011,
- A mechanic tensioner for driving the balance shafts. The tensioner is screwed onto the block and lubricated with oil,
- A mechanic tensioner for driving the oil pump. Special tool T40011 has to be used for locking it.

To set the timing, the marks on the toothed gears must coincide with the three darker links on the two chains. There are darker links only on one side of the chain in order to guarantee a single assembly position.

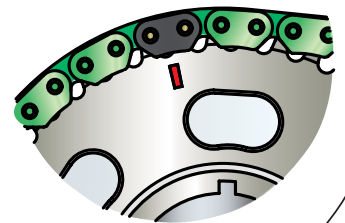

Balance shaft toothed gear

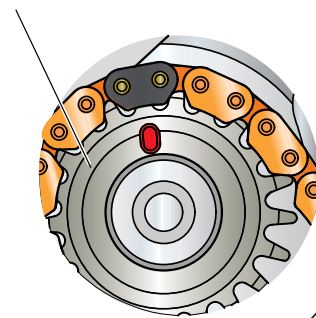

Hydraulic tensioner

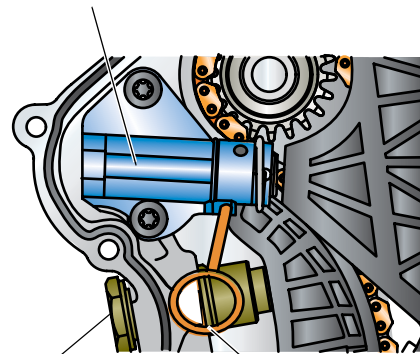

Lubricated mechanical tensioner

Special tool T40011

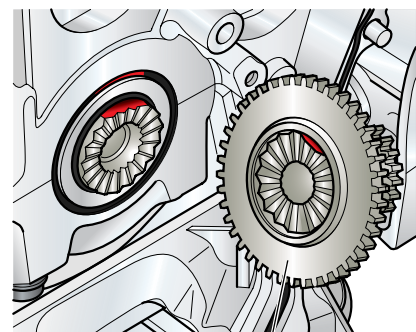

Toothed gears module

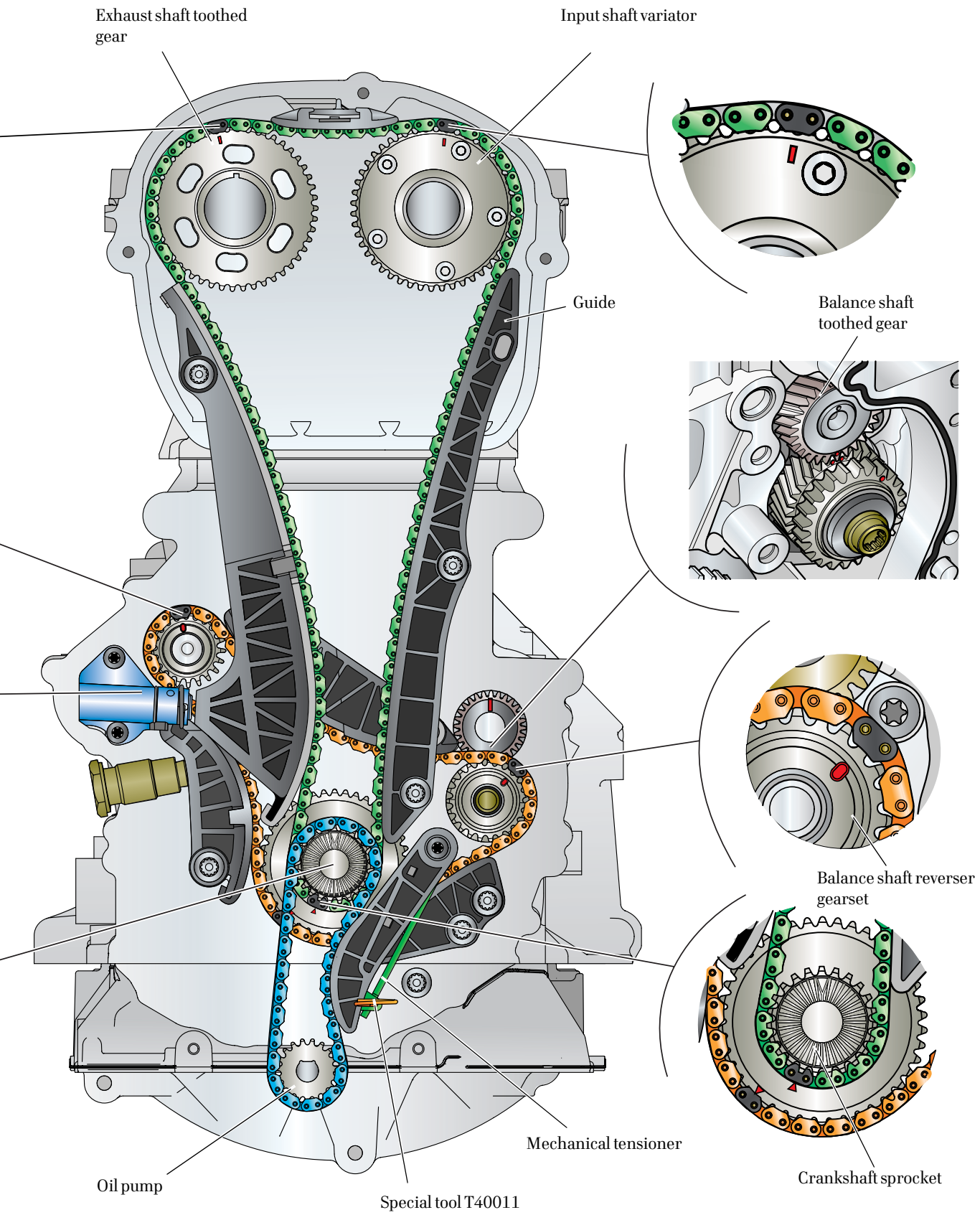

S401_013

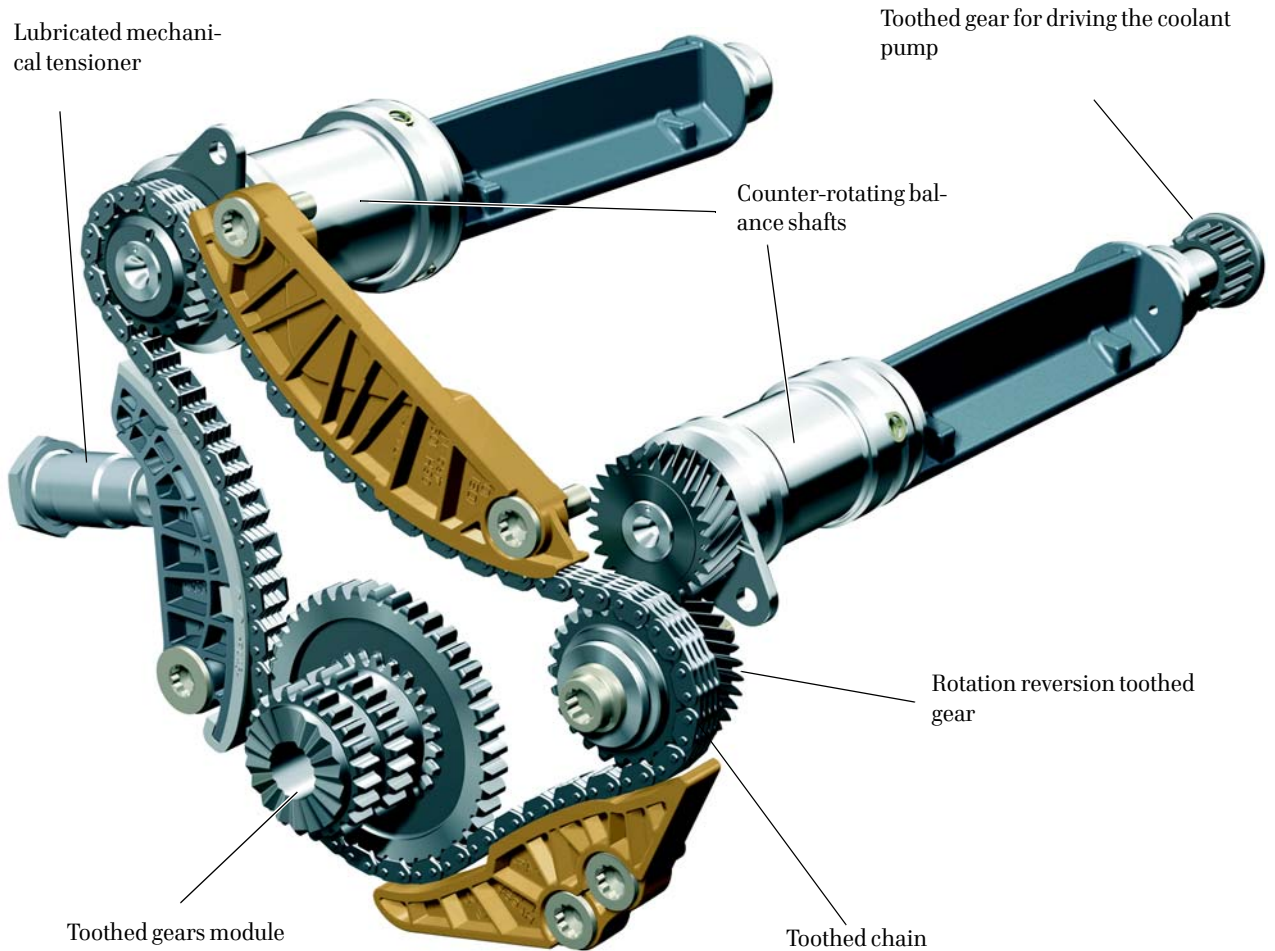

S401_014

Counter-rotating balance shafts

To improve engine running smoothness two balance shafts have been fitted. They compensate for part of the basic forces involved in engine running and thus the second magnitude oscillations are prevented. For this purpose, the shafts must rotate opposite to each other and at twice the speed of crankshaft rotation (Lanchester balancing).

Opposite direction movement of one of the shafts is achieved by means of an intermediate toothed gear with slanted teeth (oblique). To double the speed of rotation the chain is driven by a toothed gear of twice

the crankshaft's diameter.

For improved compensation the balance shafts have been displaced to the inside of the engine block, above the crankshaft. This new position allows for a more compact engine, reducing the height of the engine, and provides greater strength against torsion forces, as well as preventing foam building up in the sump oil.

At the intake end of the balance shaft there is a toothed gear for driving the coolant pump. It is driven by means of a belt.

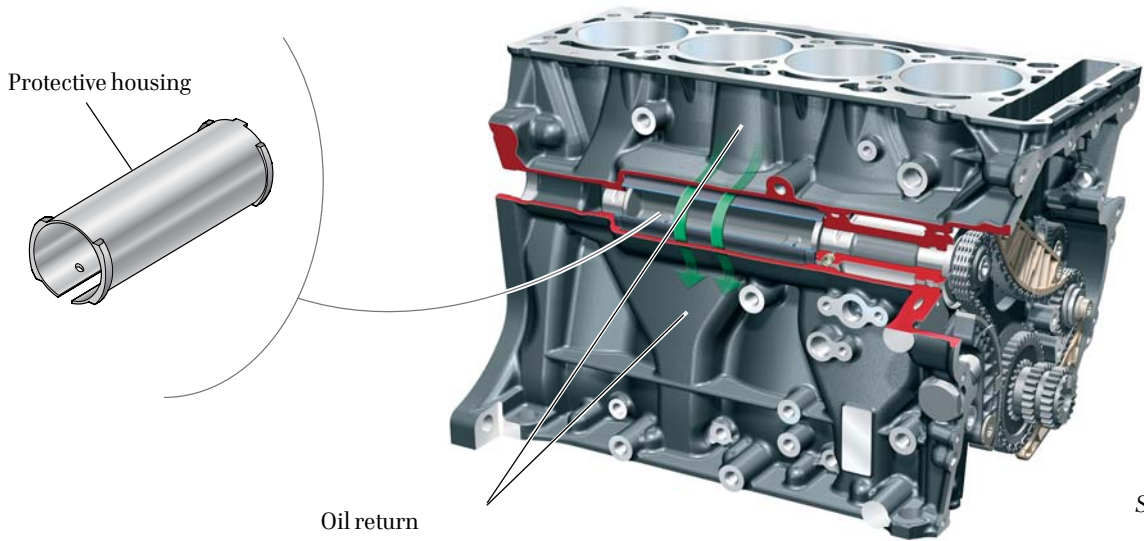

S401_015

The oil from the cylinder head returns to the sump through a passage machined on the exhaust side of the engine. The return passage goes through the space where the balance shaft is placed.

So that the oil does not come in contact with the balance shaft, a plastic housing has been added to prevent splashing from constant rotation of the balance shaft. The oil slips down the walls of the housing to the sump.

In the timing belt area, the balance shafts are screwed to the engine block by a small screw, thus guaranteeing a single assembly position. Also, the toothed gears have a mark for setting the timing belt.

At the inlet end of the balance shaft there is a seal to prevent oil leaking, as the coolant pump toothed gear is outside the engine block.

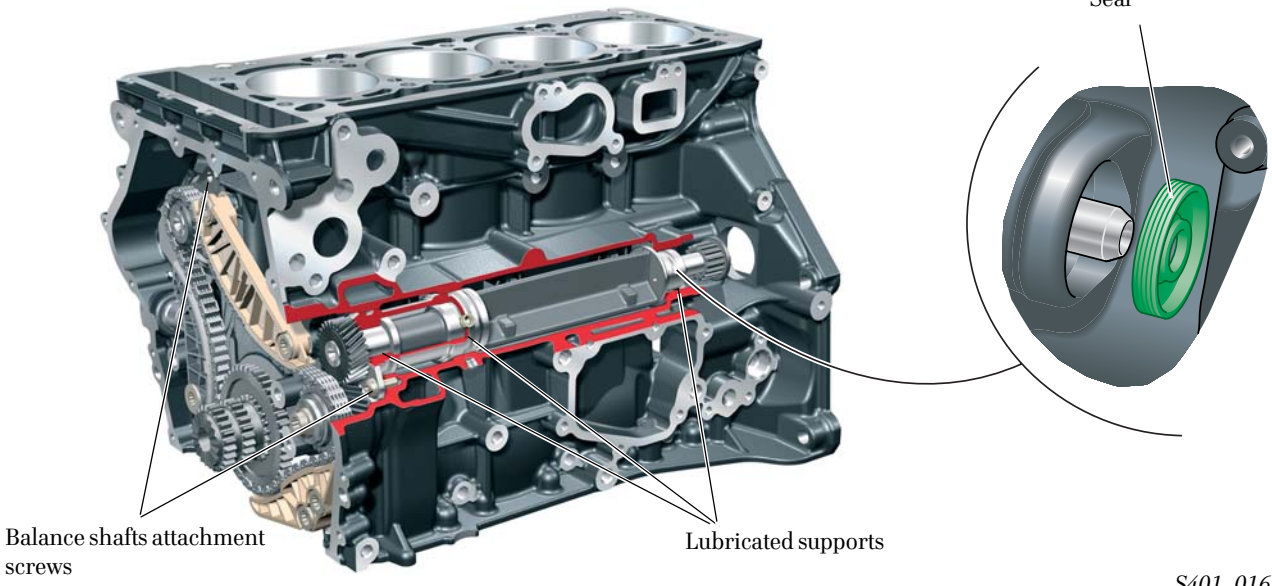

S401_016

Mechanicals

Auxiliary elements mounting

The auxiliary elements mounting includes the alternator and the climate system compressor. There is also an automatic belt tensioner screwed onto this mounting, which provides the correct tension to the Poly-V belt. To remove the tensioner it is necessary to use the special setting tool T10060A.

As a new feature, this mounting houses the oil pressure sensor, the oil radiator and the oil filter. This means that the auxiliary elements mounting becomes part of

the engine lubrication and cooling circuit.

This new position of the filter means it can be accessed without having to remove any component of the engine or the vehicle.

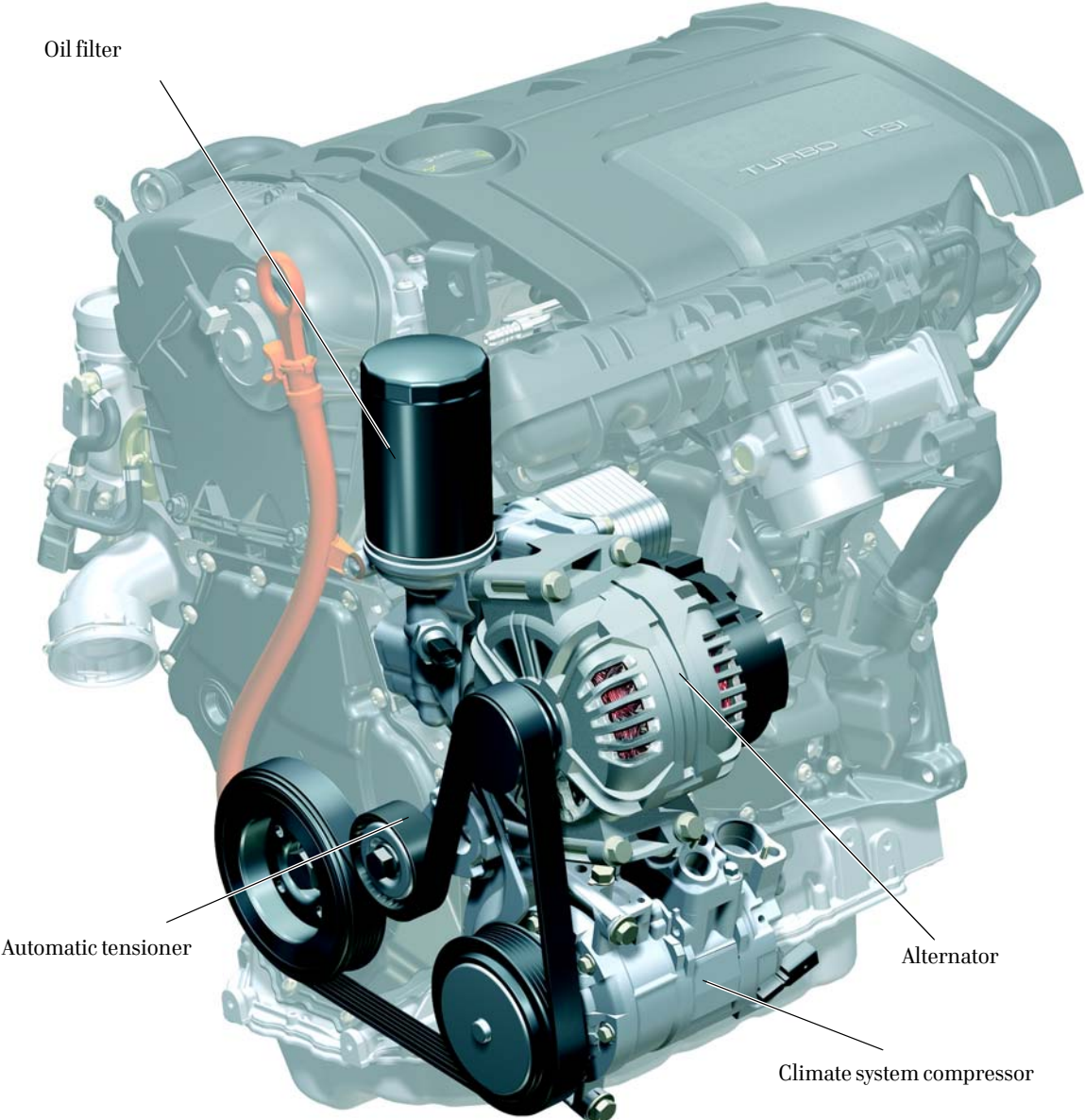

S401_017

Turbocharger

The turbocharger makes up an assembly with the exhaust manifold and is attached by its lower part by a long plate that holds it against the cylinder head, thus making removal and assembly easier.

On the suction side there is an intake for the engine block blow-by vapours and another one for the tank fuel vapours.

The turbocharger is cooled by means of coolant and

lubricated by oil.

It incorporates the overboost pressure limiter solenoid valve N75, with its release valve and the air recirculation solenoid valve N249.

It has a resonator placed at the turbocharger inlet turbine (blower fan) output. Its new design allows reducing the noise made by the pressure pulses in the turbine in a more effective way.

Turbocharger pressure regulator solenoid valve N75

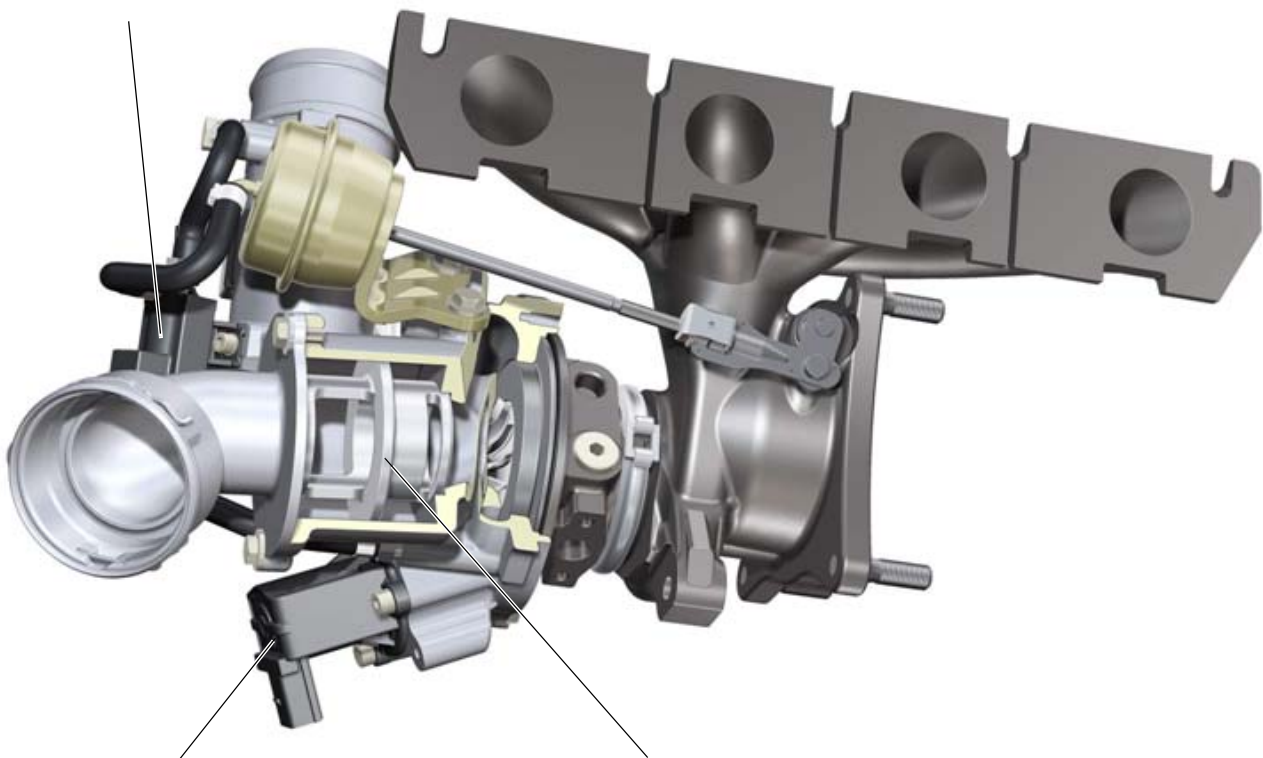

Turbocharger air recirculation solenoid valve N249

Resonance silencer

S401_018

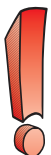

The pneumatic capsule of the release valve can be replaced separately and adjusted at the Service. For it, consult the procedures indicated in the Repairs Manual.

Air passage

Inlet manifold

The turbocharger design is conceptually very similar to the one used in the 2.0l TFSI engine. It is made up by two polyamid plastic parts bonded together, and a set of screwed-on components such as: the gas butterfly throttle, the fuel distributor rail, a double choke valve for the carbon active system, and a pneumatic actuator for the guided inlet control.

The following sensors and actuators are placed in the inlet manifold:

- Fuel high pressure sensor G247,
- Intake air temperature sensor G42,
- The inlet manifold flaps potentiometer G336,
- The injection solenoid valves N30-N33,
- The carbon active system solenoid valve N80.

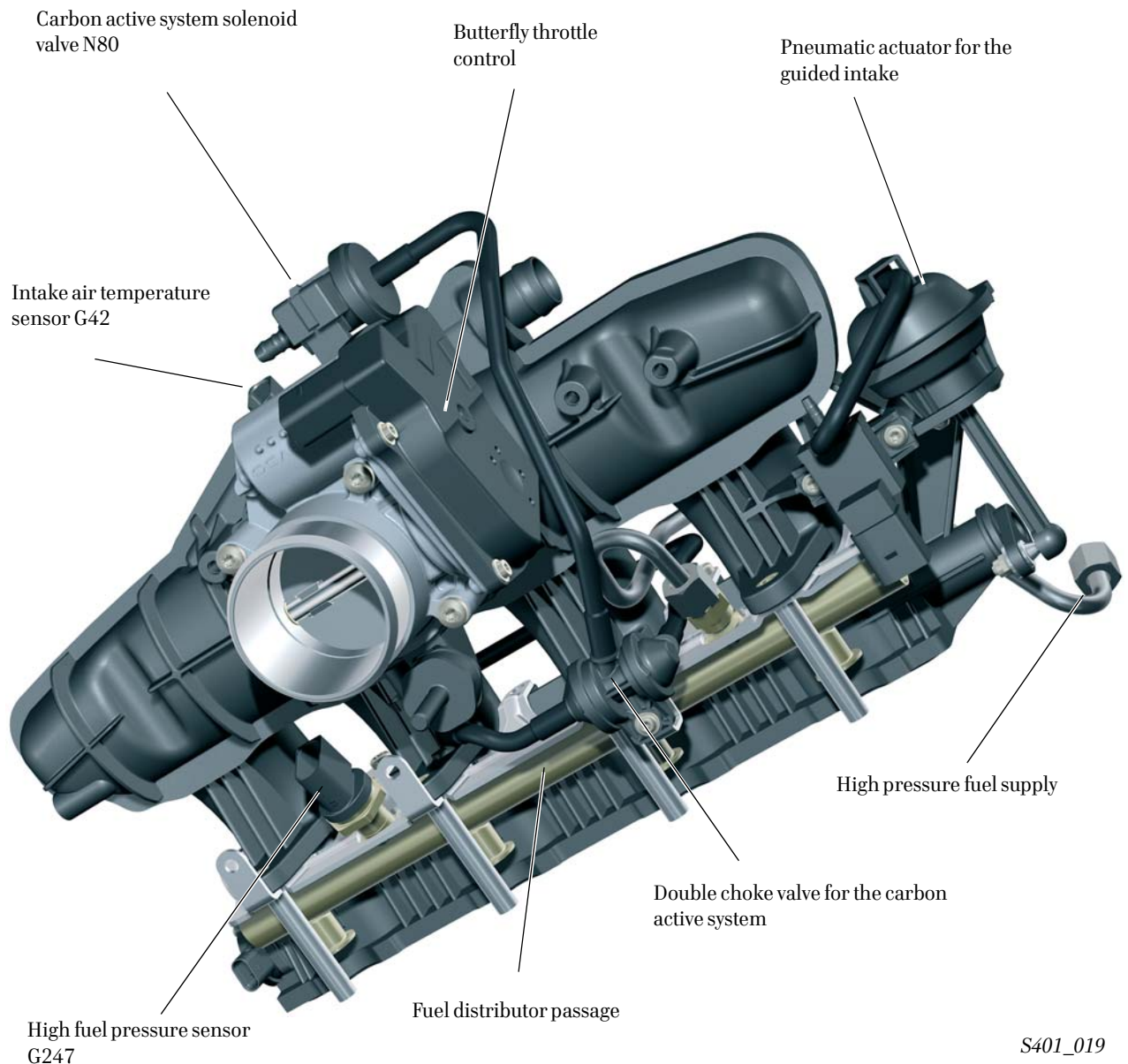

S401_019

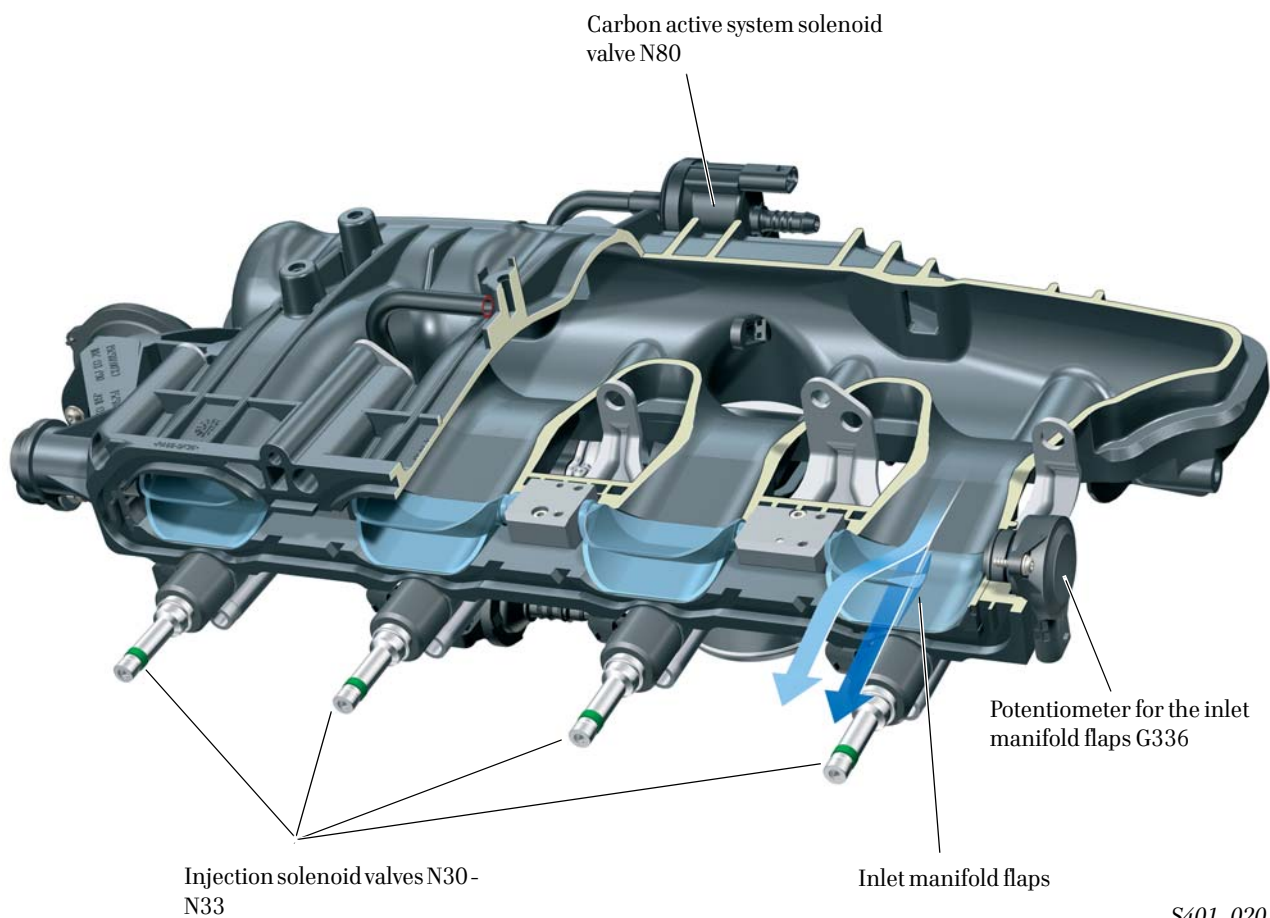

Guided intake

The guided intake system used is similar to the one on the 2.0l TFSI engine, although with some changes.

The intake flaps have a new cup-shape design, which contributes to improved sealing and absorbed air flow. The intake flaps inside the inlet manifold tubes are assembled in an offset way, which together with the new design of the flaps allows eliminating any obstacle to the passage of air when the flaps are completely open.

When the flaps are closed, the incoming air flows to the upper part of the Tumble plate, improving the mix and therefore the exhaust gases composition.

The flaps are regulated by a two position solenoid valve that activates a mechanical actuator. The mechanical actuator rotates a metal shaft to which the four flaps are attached to. A potentiometer, placed at the far end of the shaft informs the engine control unit about the position of the flaps.

The intake flaps are open at over 3000 r.p.m. Below 3000 r.p.m. they are closed, that is, at rest.

Air passage

BYT engine blow-by vapours ventilation

The 1.8l TFSI engine uses a blow-by vapours ventilation system similar to the one used in the 2.0l TFSI engine. An engine block forced ventilation system is used, which creates a constant flow of air inside the engine, dragging the existing vapours from the engine into the oil separator in order to carry out the vapours elimination process.

Fresh air intake takes is carried out behind the air filter and air mass meter. The ventilation passage is linked to the cylinder head cover by means of a choke valve.

The choke valve has a double function. On the one hand it allows air to flow towards the inside of the engine, and on the other hand it acts as a safety valve. In the event of high pressure inside the engine, the valve opens and sends the non-filtered vapours to the inlet passage, thus preventing damage to the seals due to excess vapours pressure inside the engine.

The blow-by vapours go through the thick particles separator placed on the inlet side of the engine block, which separates any existing oil particles in the vapours. These oil droplets are recovered in the separator by means of a syphon system, and are then returned to the sump. The filtered vapours are sent along a polyamid plastic tube to the engine cover for further elimination.

Because of the wide diameter of the tube the speed of the vapours flowing inside is reduced, which prevents oil building up on the passage walls. Also, the flexible tube is covered with a thermal insulation to prevent vapours condensation of the tube's walls at low temperatures.

On the engine cover there is a cyclone type separator which carries out a second and finer separation of the vapours.

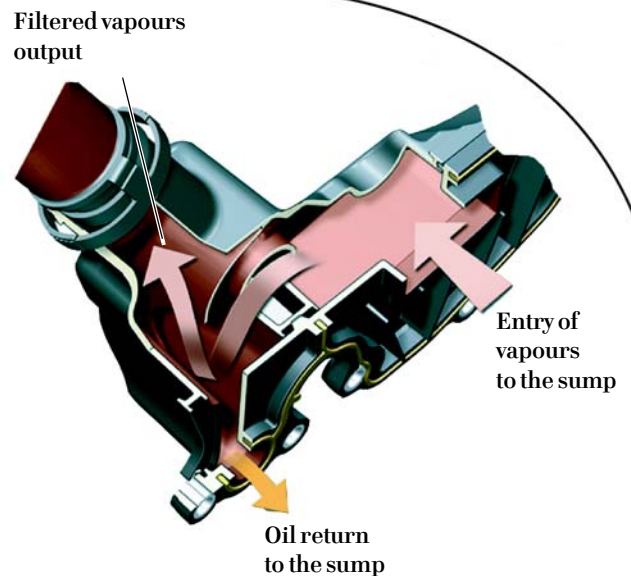
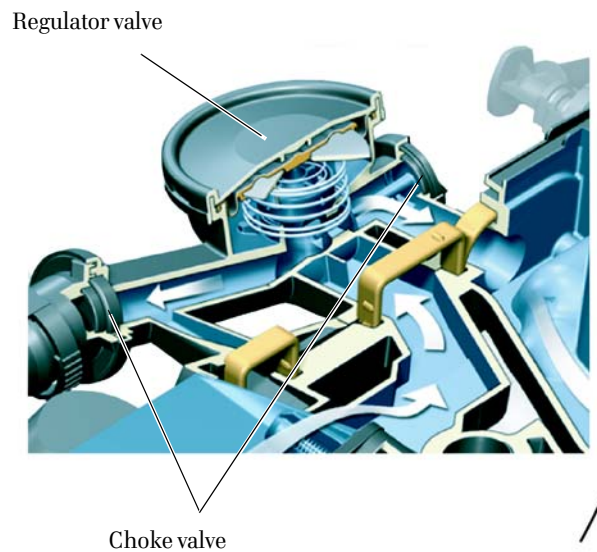

This new separator accelerates the flow of vapours and generates a turbulence that separates the small oil particles. The oil recovered returns along a passage to the sump. A choke valve has been inserted at the end of the return passage that allows oil to flow to the sump but prevents the oil from being sucked out in the event of a strong vacuum in the passage.

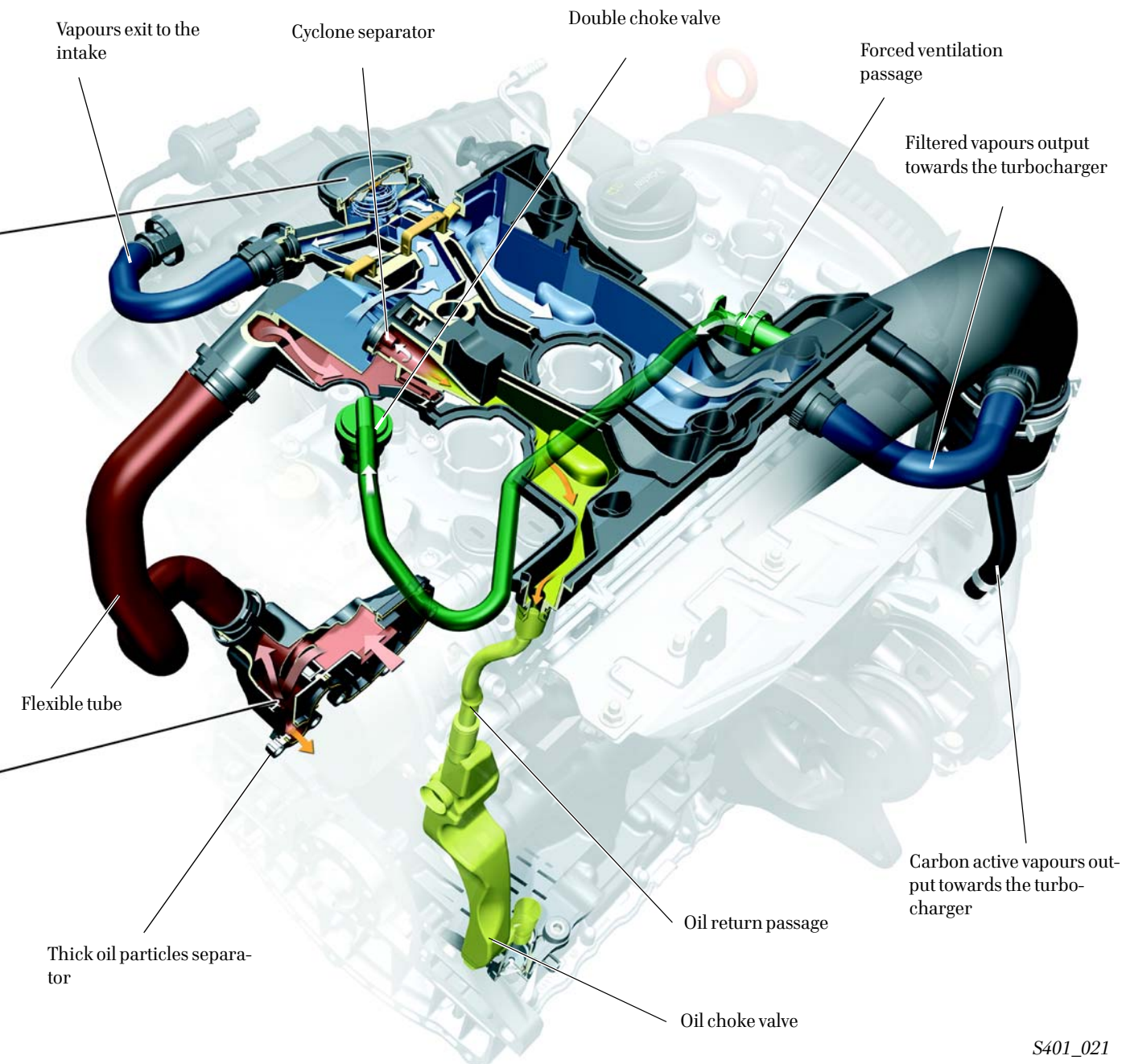

S401_021

The blow-by vapors that have gone through the cyclone separator reach the pressure regulator valve and next the two single-direction choke valves.

The choke valves regulate the absorbing of clean blow-by vapours, depending on the existing pressure in the inlet manifold. Without overboost pressure the oil vapours are sucked in as a result of the vacuum generated in the inlet manifold, just after the gas butterfly

throttle.

When overboost pressure increases, the blow-by vapours are sent to the suction side of the turbocharger, through the engine cover.

Air passage

BZB engine blow-by vapours ventilation

The main differences between the BYT engine and its evolution, the BZB engine, are to be found in the sump blow-by vapours ventilation system.

All the components that make up this system have been modified in the BZB engine in order to reduce the height and dimensions of the engine. Having a more compact engine makes it possible to fit it longitudinally or transversely in the vehicles. It also allows for greater bonnet deformation, thus reducing damage to pedestrians in the event of running over.

As with the BYT engine, the blow-by vapours inside the engine are introduced in the thick oil particles separator. The oil recovered inside it is sent to the sump and the separated vapours are channelled along a passage machined in the engine block. This way the vapours are sent through the inside of the engine, maintaining an adequate temperature all the time and also avoiding vapours condensation due to low temperatures.

The vapours that reach the cylinder head cover are directly introduced in the module for further elimination. Inside the module, the vapors are driven through the thin oil particles separator, cyclone type, where any oil droplets that might have condensed are recovered and resent to the sump through a passage.

The separated vapours reach the pressure regulator valve. This new valve, of a larger diameter, regulates the volume of vapours to be eliminated in the combustion chamber.

From the regulator valve the vapours are sent to the combustion chamber via one of the two single-direction choke valves. The choke valve under greater vacuum will open the passage allowing the vapours to be sucked in to the inlet manifold or to the suction side of the turbocharger.

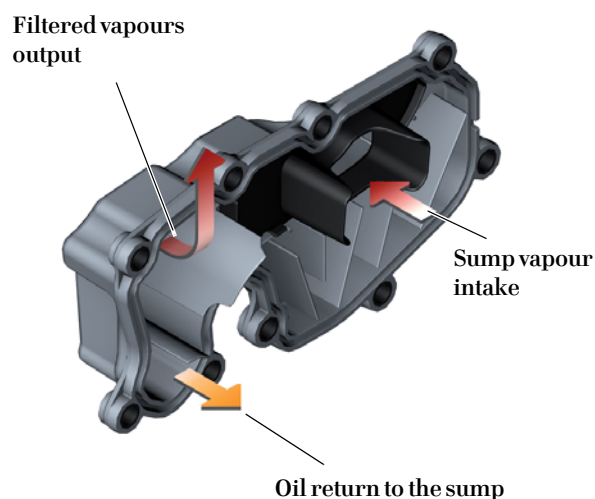
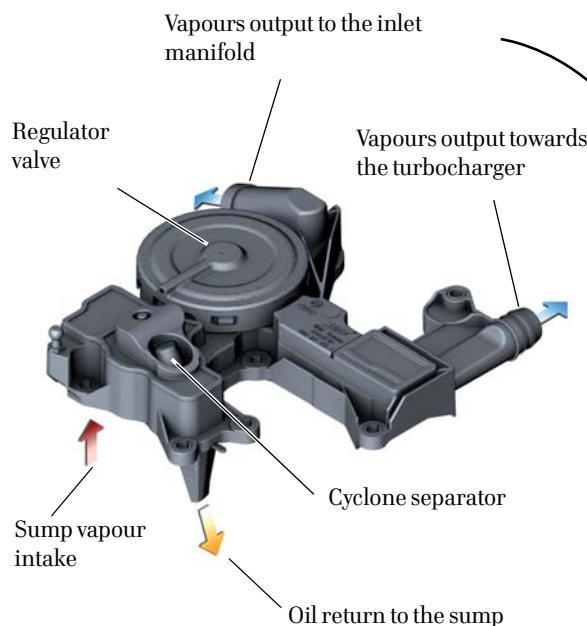

The passage for the engine block forced ventilation system has been eliminated together with the choke valve it included. This choke valve has been replaced by a safety valve placed inside the module.

Filtered vapours output towards the turbocharger

Oil vapours elimination module

Vapours output to the intake

Passage for sending the vapours to the cylinder head

Thick oil particles separator

Oil return to the sump

S401_022

In the event of high pressure inside the engine, this safety valve opens and sends the non-filtered vapours to the suction side of the turbocharger, thus preventing damage to the engine seals.

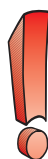

The components that make up the sump blow-by vapours ventilation system have been modified in the BZB engine. In spite of this, the system works just like in the BYT engine.

Air passage

Carbon active system

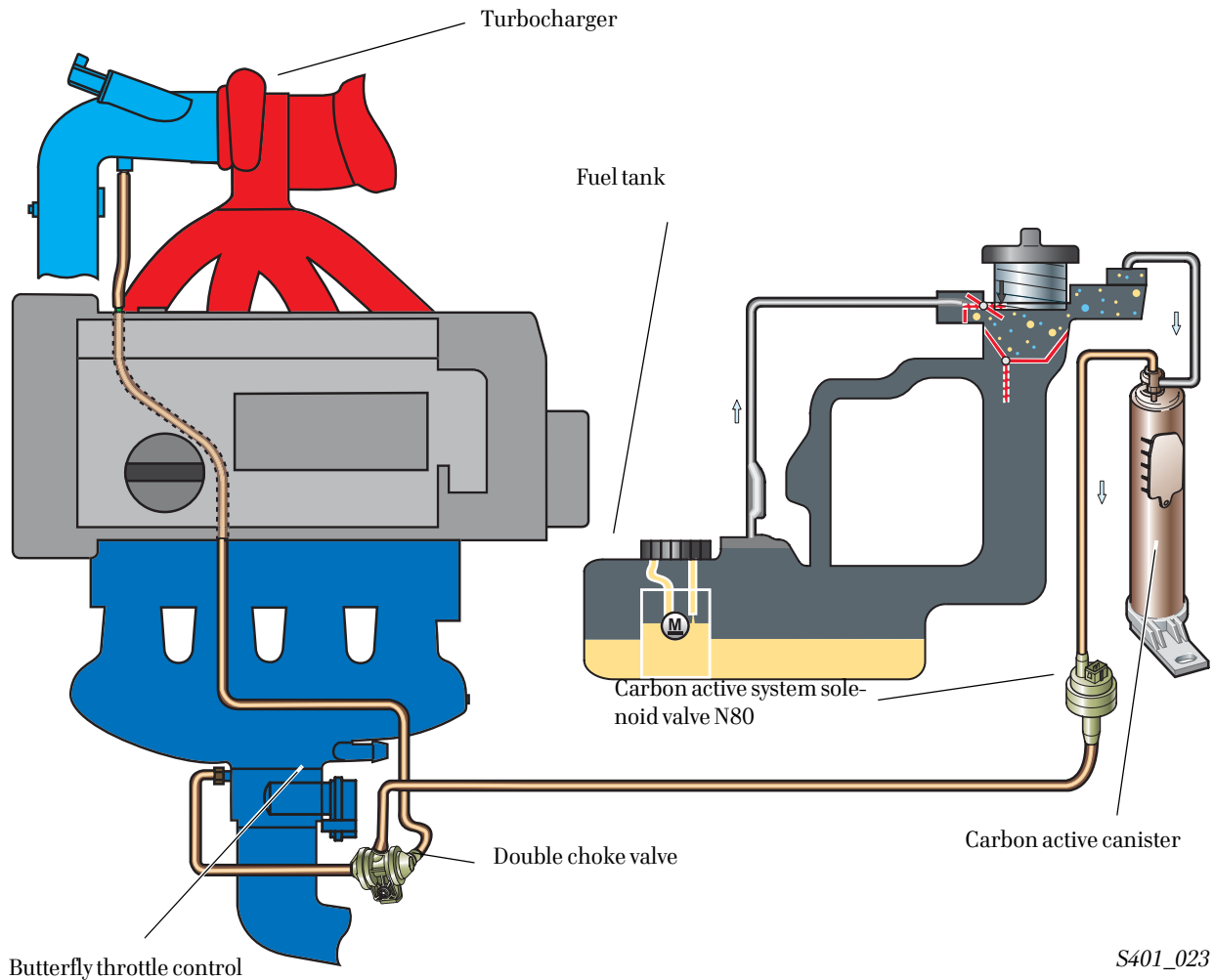

The carbon active system is in charge of sending the fuel tank vapours to the inlet manifold so that they are eliminated in the engine combustion chamber.

The carbon active system is made up by a filter, a solenoid valve and the double choke valve.

The carbon active canister solenoid valve N80 is controlled by the engine control unit and regulates the passage of vapours contained in the carbon active filter to the double choke valve.

The double choke valve is activated pneumatically depending on the existing pressure in the inlet manifold. The vapours are sent to the inlet manifold when there is no intake pressure, or to the suction side of the turbocharger when there is overboost pressure. In this case, the engine cover is used for transporting the fuel vapours from the inlet side to the exhaust side of the engine.

The solenoid valve and the double choke valve are placed in the inlet manifold.

Vacuum system

Vacuum supply to the brake servo and the engine consumers is achieved by means of a vacuum pump attached to the cylinder head and driven by the exhaust camshaft, just behind the fuel high pressure pump. Only the brake servo and the guided intake system use the vacuum circuit.

The vacuum pump provides vacuum under any engine running condition. That is why it is not necessary to use an additional vacuum tank. The pump's operation has been devised so that it can maintain an absolute pressure rate of 50 mbar when the engine is running.



S401_024

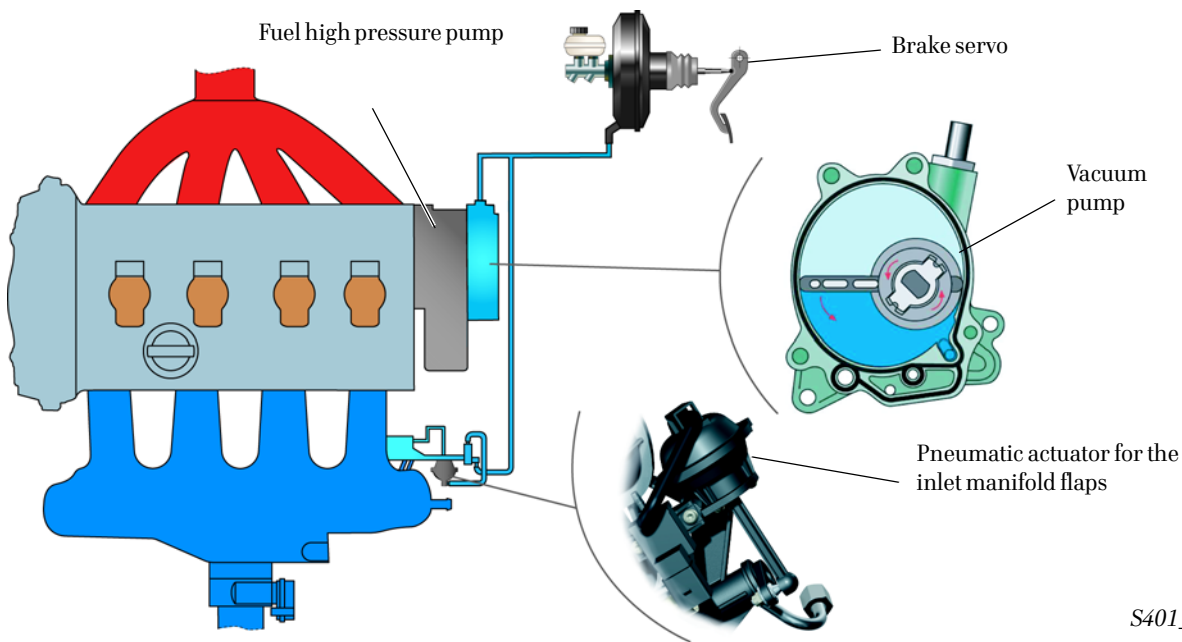

S401_025

Vacuum pump

The vacuum pump is made up by a rotor placed in an offset position to the housing, and a metal vane that divides the vacuum pump into two chambers. When the rotor rotates, the position of the vane is constantly changing, which makes the volume of one chamber increase while the volume of the other chamber decreases.

The pump sucks in the air from the vacuum system and sends it to the cylinder head together with the excess oil, through a metal sheet valve.

The oil for lubricating the rotor and for sealing the vane on the pump housing is supplied through a passage in the cylinder head, running from the camshaft to the vacuum pump. In that very lubrication point the quadruple cam for the fuel high pressure pump is supplied.

Lubrication system

Oil pump

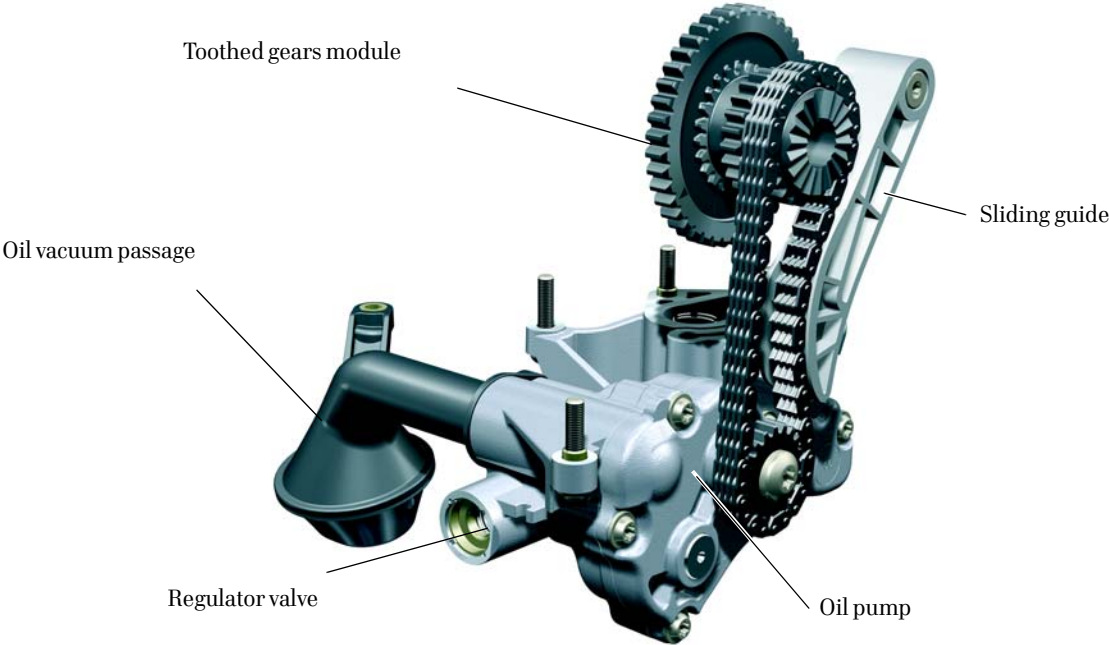

S401_026

The oil pump is screwed onto the upper sump and is driven by the crankshaft by means of a chain.

The oil pressure is regulated inside the pump by the regulator valve. This valve maintains a constant pressure inside the circuit and is made up by a metal piston

and a spring rated at 3.5 bar.

A safety valve, made up by a metal ball and a spring rated at 11 bar, prevents pressure excess in the circuit, mainly during cold start.

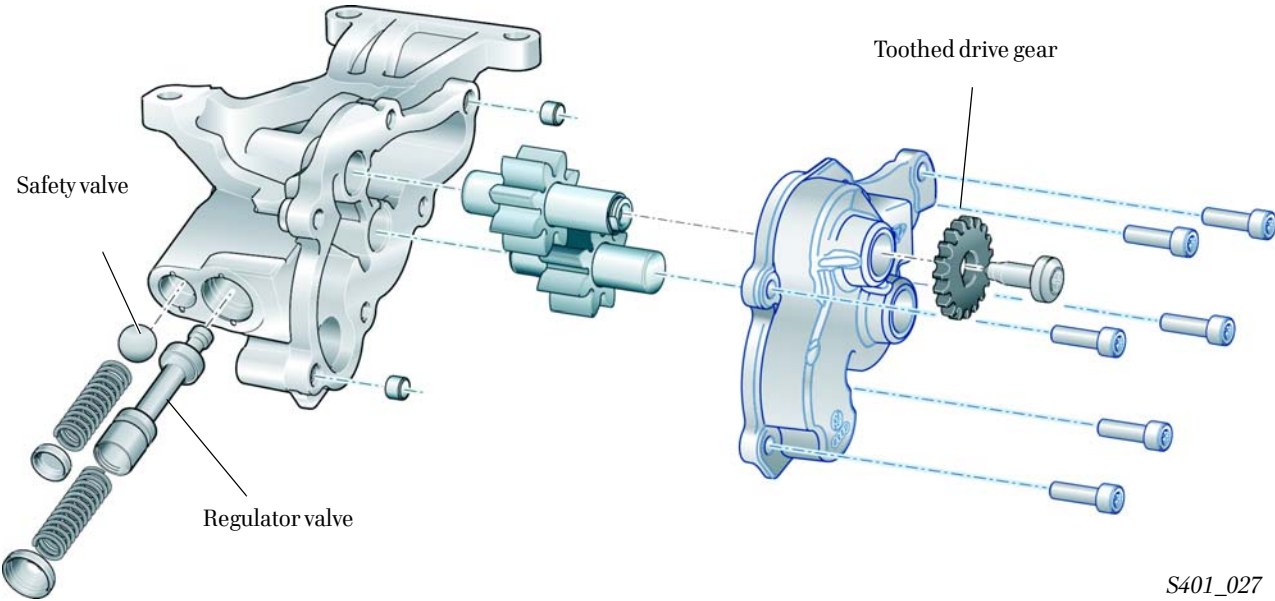

S401_027

Oil filter

The oil filter is screwed onto the auxiliary groups mounting, and is accessible from the upper part of the engine.

When the oil filter is fitted and screwed-on in place, the pressurised oil from the oil radiator is driven through the filter. The oil pressure opens up the non-return valve inside the filter and allows the filtered oil to flow to the engine lubrication circuit.

When unscrewing the filter the polyamid ESPIGA placed inside the groups mounting is released. When the ESPIGA moves upwards, it opens a return passage and allows for the accumulated oil in the mounting to be sent to the sump.

To replace the filter it has to be unscrewed and then wait for 2 or 3 seconds before removing it and thus prevent any oil from falling on the engine.

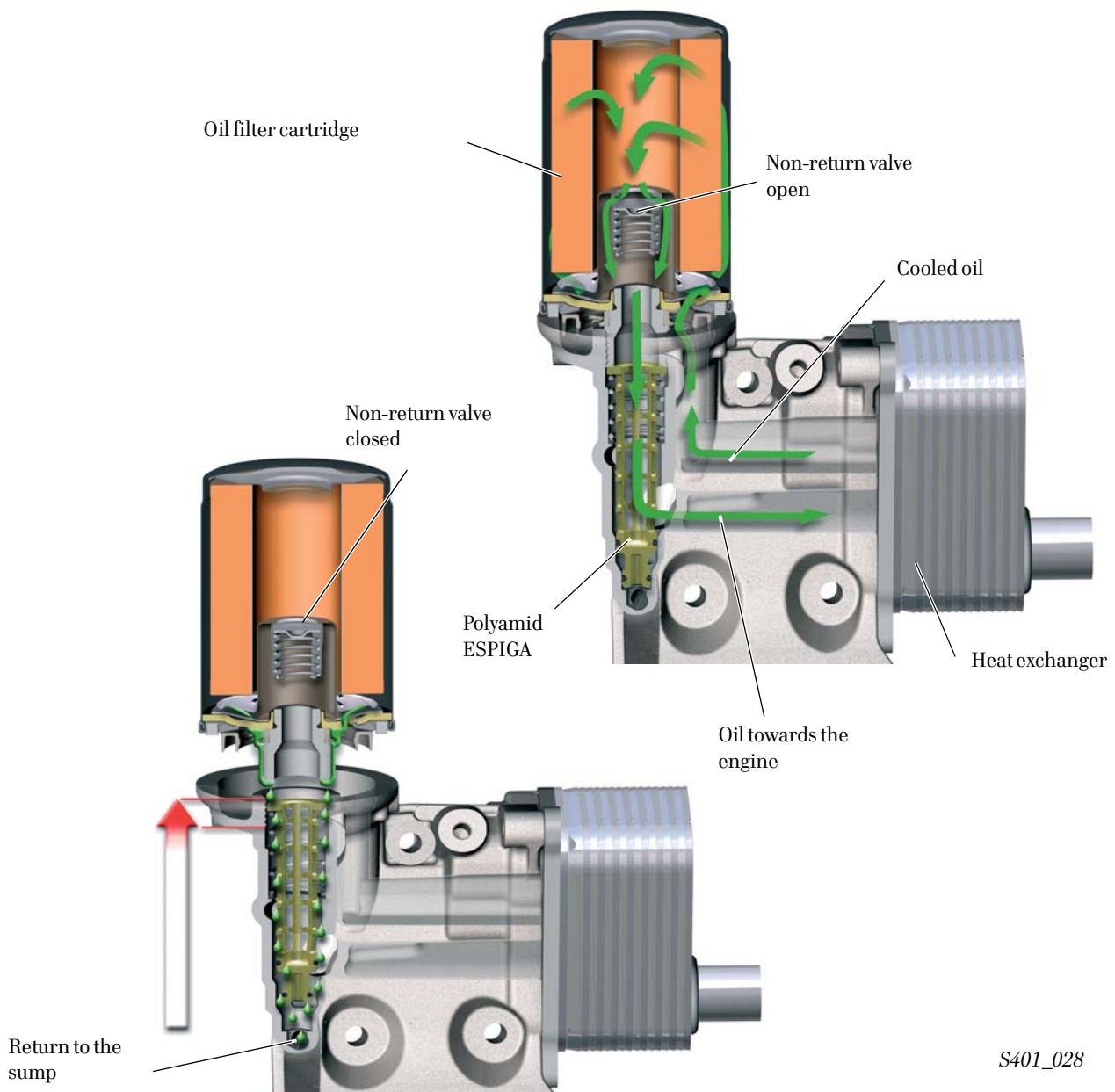

S401_028

Cooling system

Cooling circuit

This cooling circuit operates under the cross-flow principle. The coolant flows from the radiator to the coolant pump module, which drives it to the inside of the engine block.

Like in other overboosted petrol engines, the circuit has an electrical pump, V51, for coolant post-circulation. This pump protects the turbocharger, after stopping the engine, against excess heating up after being

under intense loads and thus prevents the oil accumulated in the blower fan shaft from carbonizing.

The electrical pump is activated by the engine control unit for a maximum of 15 minutes from the moment of switching off the ignition. During this period of activation, the pump drives the coolant from the radiator to the turbocharger, in the opposite direction.

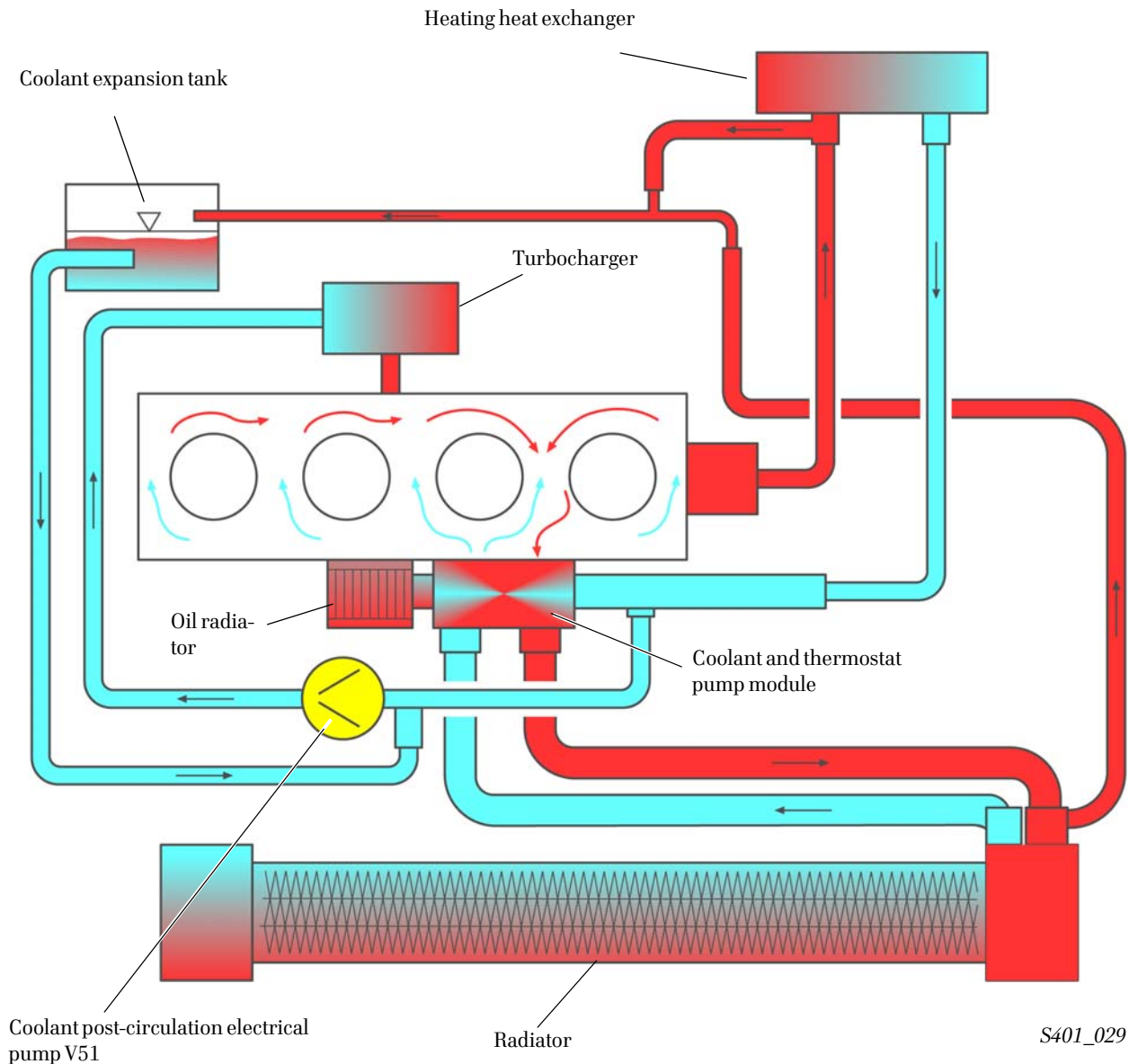

S401_029

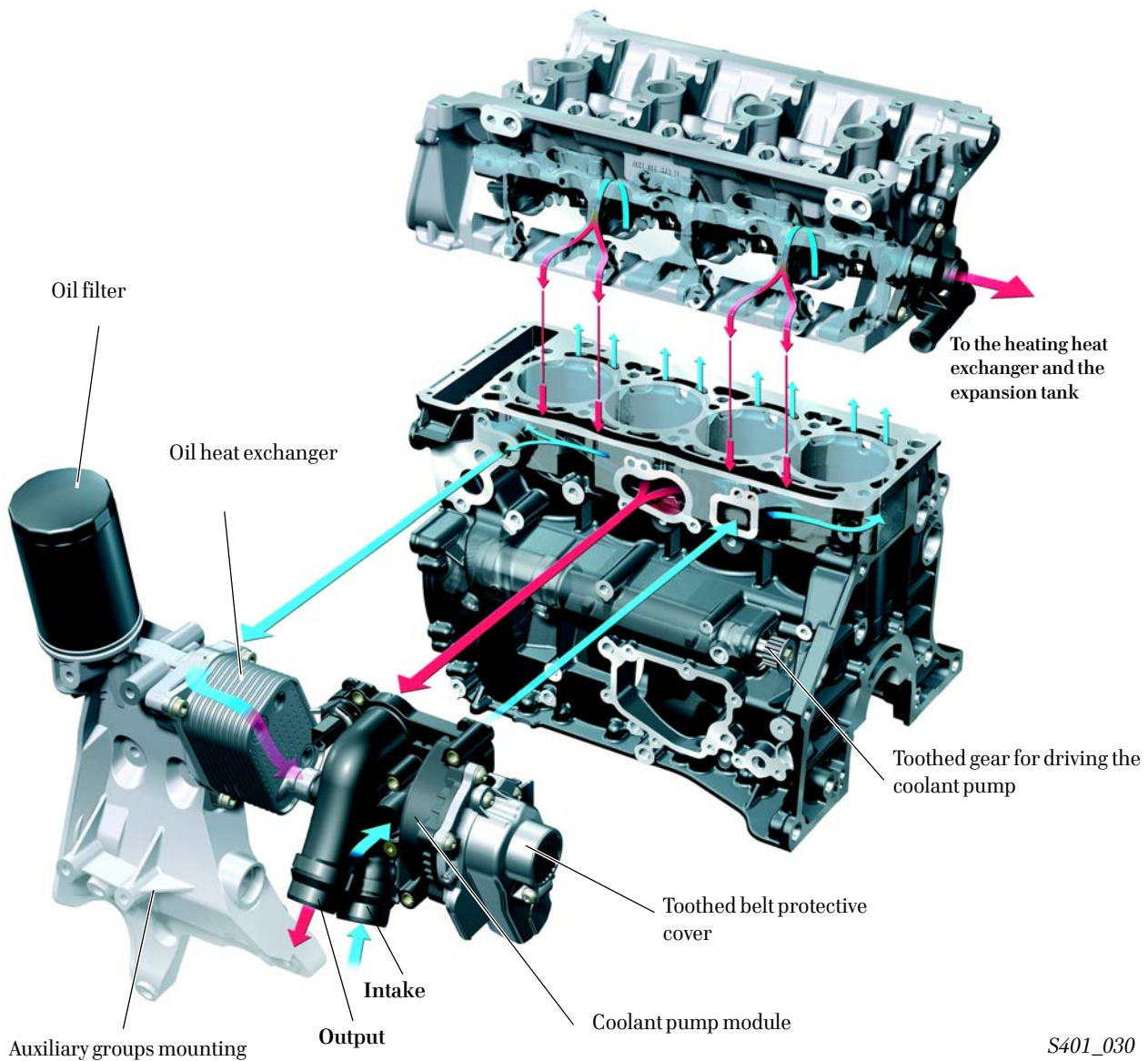

S401_030

The coolant from the radiator is driven by the pump to the inside of the engine block. The coolant flows from the inlet side to the exhaust side of the engine block, surrounding the cylinders. Next, the coolant is channeled to the cylinder head, cooling it from the exhaust side to the inlet side. The heated coolant is collected in a collector chamber and sent to the pump module where the thermostat is placed. Depending on the temperature of the coolant at that point, the flow is sent to the radiator to be cooled (the thermostat opens from 95°C)

or is directly driven to the pump (thermostat closed).

Part of the coolant is diverted through a small passage in the engine block to the oil radiator placed on the auxiliary groups support.

At the end of the cylinder, on the flywheel side, part of the coolant is channeled to the heating heat exchanger and to the coolant expansion tank.

Cooling system

Coolant pump module

The coolant pump, the G62 coolant temperature sensor, and the thermostat are placed in a module. This module is screwed onto the engine block from under the inlet manifold.

The balance shaft drives the coolant pump by means of a belt. The two toothed gears used reduce the transmission ratio, thus reducing the number of revs and almost equalising the speed of rotation to that of the crankshaft.

To achieve such a down gearing a larger diameter

toothed gear is used on the drive shaft of the coolant pump. On this shaft and welded to the toothed gear there is a wheel with vanes which rotates as a single assembly with the pump. This wheel with vanes acts as a fan and is used to introduce air and cool the belt. This air cooling system driven by a belt is maintenance free.

Only the thermostat, the temperature sensor, and the belt cover can be replaced as single parts references. There is a centering pin on the housing for correct thermostat assembly.

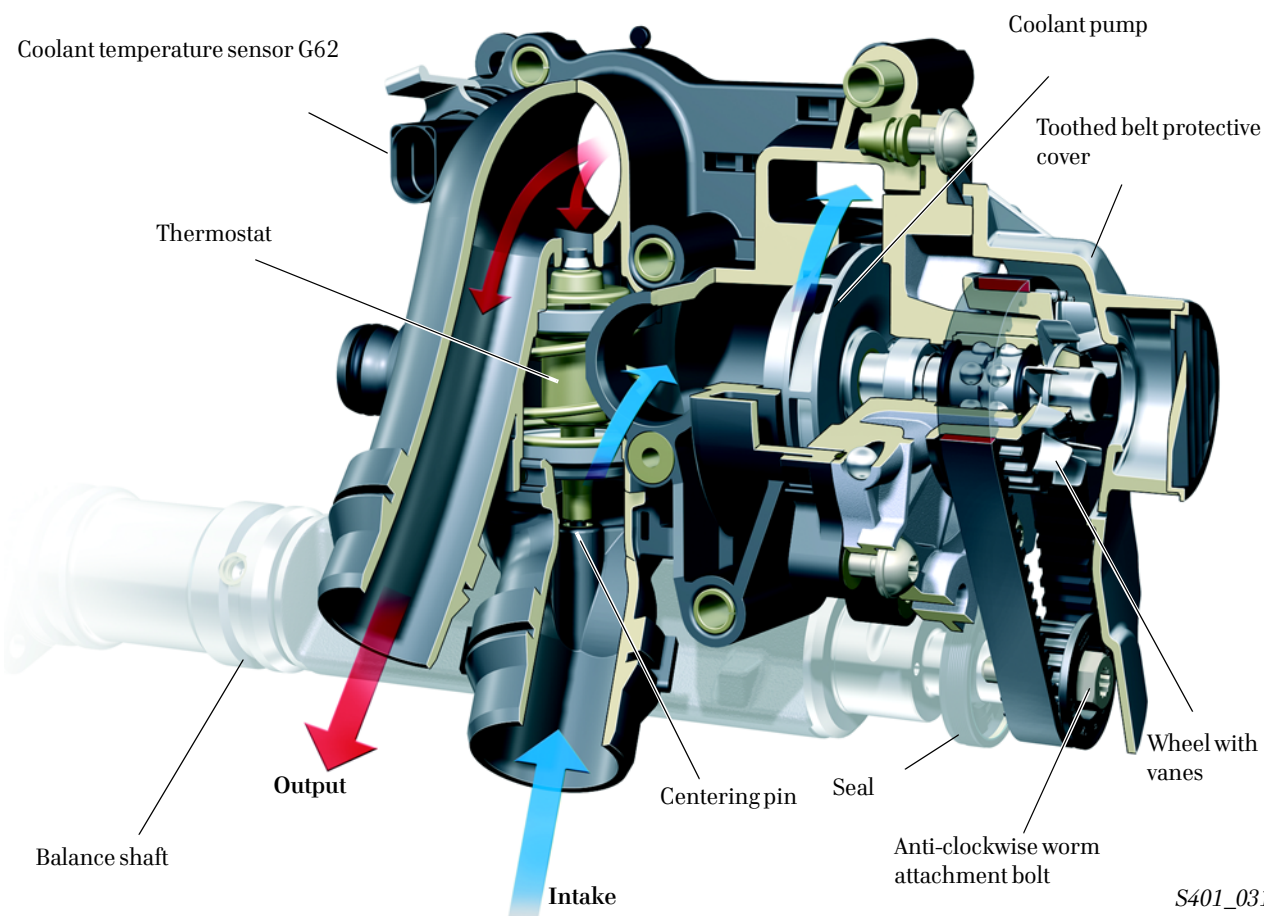

S401_031

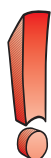

The belt is tensioned by means of a preset assembly position defined by the coolant pump on the housing, and can not be adjusted with any workshop means. The balance shaft toothed gear attachment bolt has an anticlockwise worm and you need to use the special tool T10361 and the V.A.G 1331 to remove it.

Fuel supply system

Low fuel pressure circuit

The fuel supply system is an evolution of the one used in the 2.0l TFSI engine and is made up by a passage for low pressure fuel supply, a high pressure pump, a high pressure fuel distributor rail and four injectors.

All components that come into direct contact with the fuel have been designed in such a way that the engine can run with all fuel qualities available worldwide.

The low pressure fuel passage does neither have a low pressure sensor nor a release or return valve.

Correct fuel pressure is calculated by the engine control unit, which sends a fixed frequency and variable duty cycle signal to the electrical pump J538, placed in the fuel tank, for achieving the appropriate pressure in the low pressure circuit (between 4 and 8 bar).

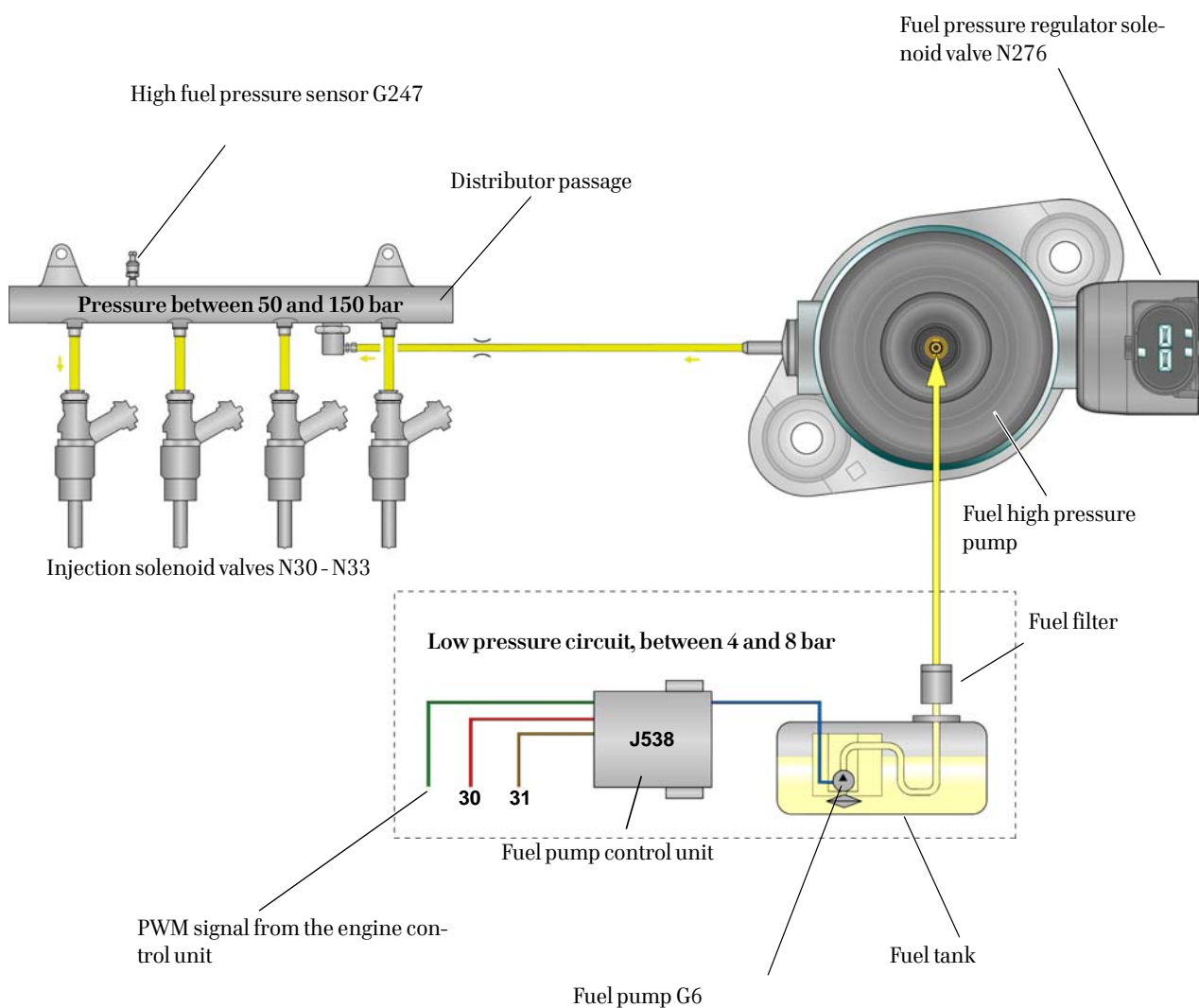

S401_032

Fuel supply system

Fuel high pressure circuit.

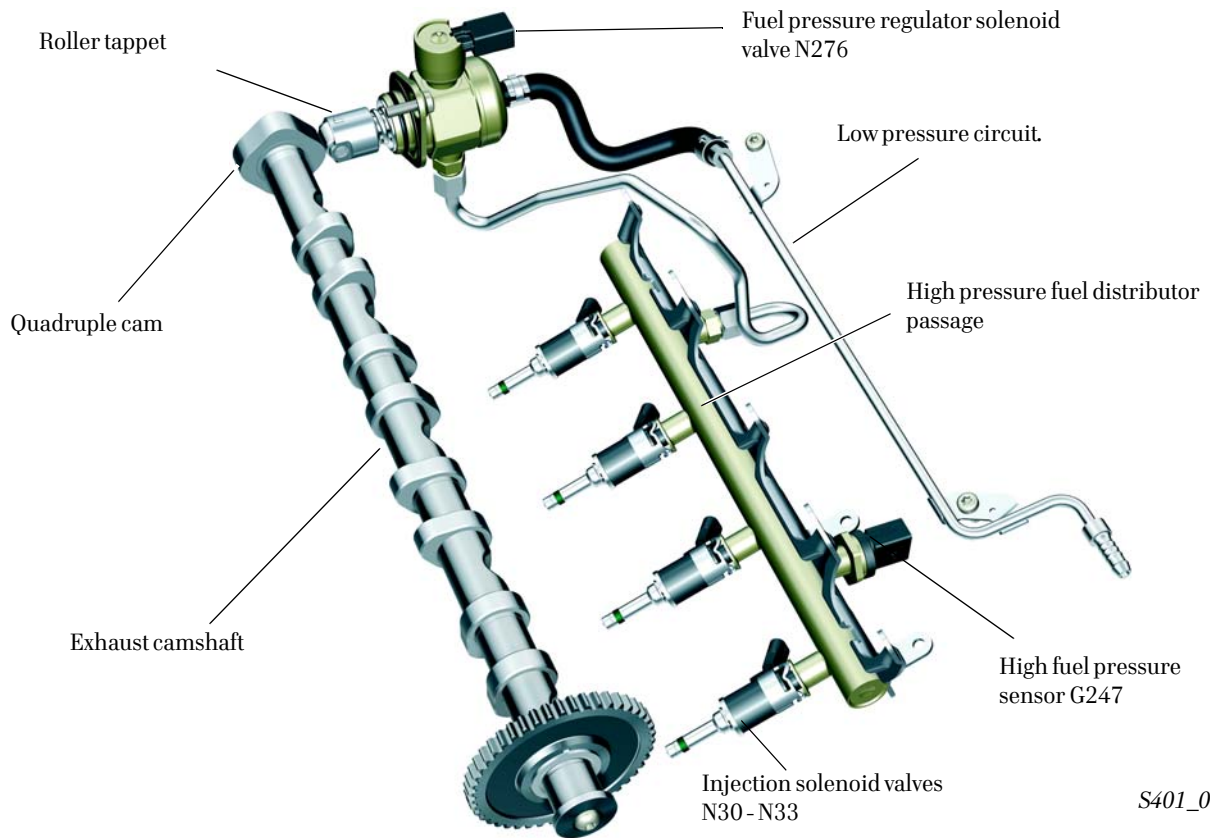

S401_033

The high pressure pump is activated by a quadruple cam placed at the end of the exhaust camshaft. The number of cams has been increased compared to the 2.0l FSI engine and the 2.0l TFSI engine, where the pump was activated by a double cam and a triple cam, respectively.

The quadruple cam drives the pump piston by means of a roller tappet. This is how friction is reduced as well as the forces to be transmitted by the chain. The result is reduced wear and smoother running of the engine, less noise and fuel consumption reduction.

The release valve has been eliminated from the high pressure circuit and replaced by a valve placed inside the mechanical pump. This valve opens from a pressure of 200 bar and resends the fuel to the low pressure circuit. This is how it prevents damaging any component

due to excess pressure, mainly in deceleration phase and in the phase after engine warm up.

The fuel distributor rail is made of stainless aluminium and supplies high pressure fuel to the injectors.

The pressure in the high pressure circuit is adjusted by the regulator solenoid valve N276, placed in the high pressure mechanical pump. The pressures in the high pressure circuit can vary between 50 and 150 bar, depending on the engine load.

The engine control unit always knows the pressure in the pressure distributor rail from the pressure sensor G247. This is how it can control the solenoid valve N376 and adjust the pressures in the high pressure circuit. The G247 sensor is capable of measuring up to 200 bar of pressure.

High pressure pump

The high pressure pump is much smaller than the one used on the 2.0l TFSI engine. This has been possible, partly, because of using a quadruple cam.

Adjusting the fuel pressure demanded by the engine control unit is carried out by the fuel pressure regulator solenoid valve N276, placed at the upper part of the pump. The pulses in the low pressure circuit are reduced by means of a damper membrane placed inside the pump.

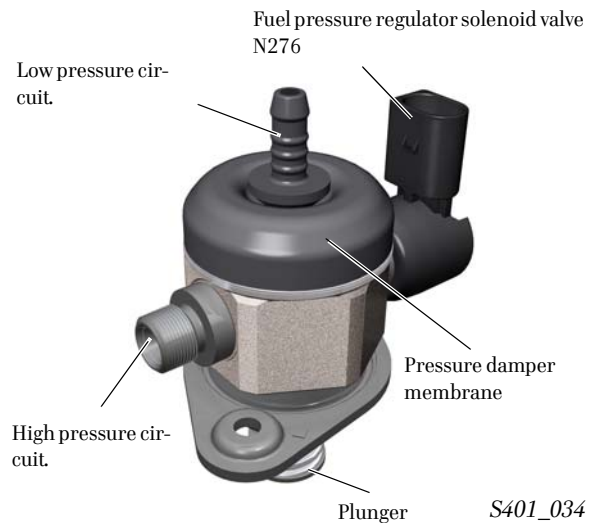

S401_034

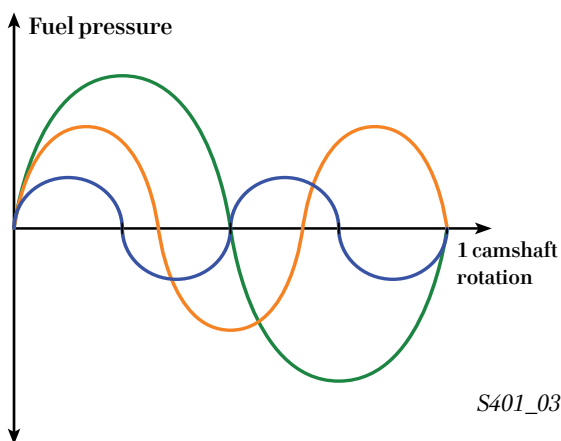

S401_035

- 1.8l TFSI engine- Quadruple cam
- 2.0l TFSI engine- Triple cam
- 2.0l FSI engine - Double cam

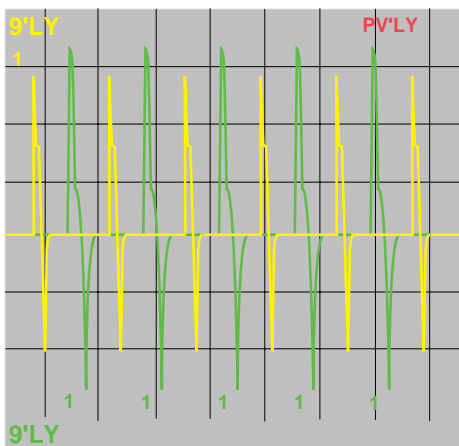

- Fuel pressure regulator solenoid valve
- Fuel injection solenoid valves.

S401_036

Quadruple cam

Using a quadruple cam allows for reducing the height of the cam, which is now 3.5 mm compared to 5 mm in the 2.0l TFSI engine. This reduces the stroke of the piston and the flow driven by the stroke. This way, not only the size of the pump is reduced but also the system is pressurised in a faster way and with less pressure fluctuations improving engine start and acceleration phase.

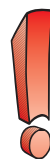

On the graph you can see the advantages provided by the progressive increase of the number of cams in the FSI engines regarding pressure oscillations in the circuit.

For every camshaft rotation there are four pump piston drive strokes, two camshaft rotations and therefore, four fuel injections. As a result, there is an increase of pressure in the distributor rail after every injection thus improving the amount injected in each cylinder because of all the injectors having the same fuel pressure conditions at the moment of injection. This is how the lambda regulation is improved and as a result fuel consumption is reduced.

Synoptic chart

Air mass meter G70
Intake air temperature sensor 2 G299

Engine revs sensor G28

HALL SENSOR G40

Electronic accelerator pedal position sensor G79 - G185

Butterfly throttle position sensor G187 - G188

Radiator output coolant temperature sensor G83.

Coolant temperature sensor G62

Knock sensor G61

Inlet manifold pressure sensor G31

Lamba sensor G39

High fuel pressure sensor G247

Brake light switch F and brake pedal switch F63

Clutch pedal position sensor G476

Intake air temperature sensor G42

Terminal +/-DF alternator

Potentiometer for the inlet manifold flaps G336

Additional signals:
- Cruise control GRA

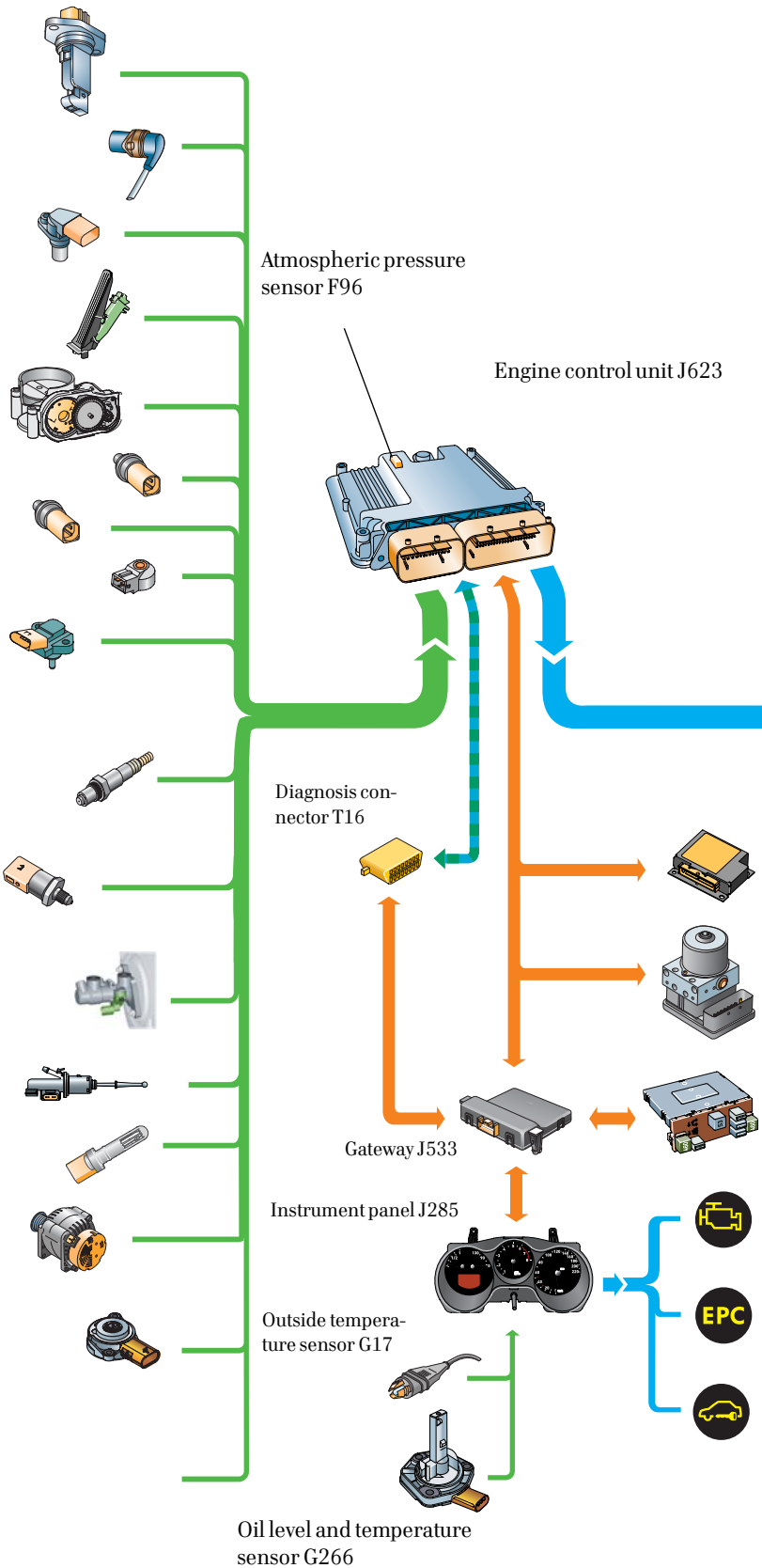

Fuel pump control unit 538

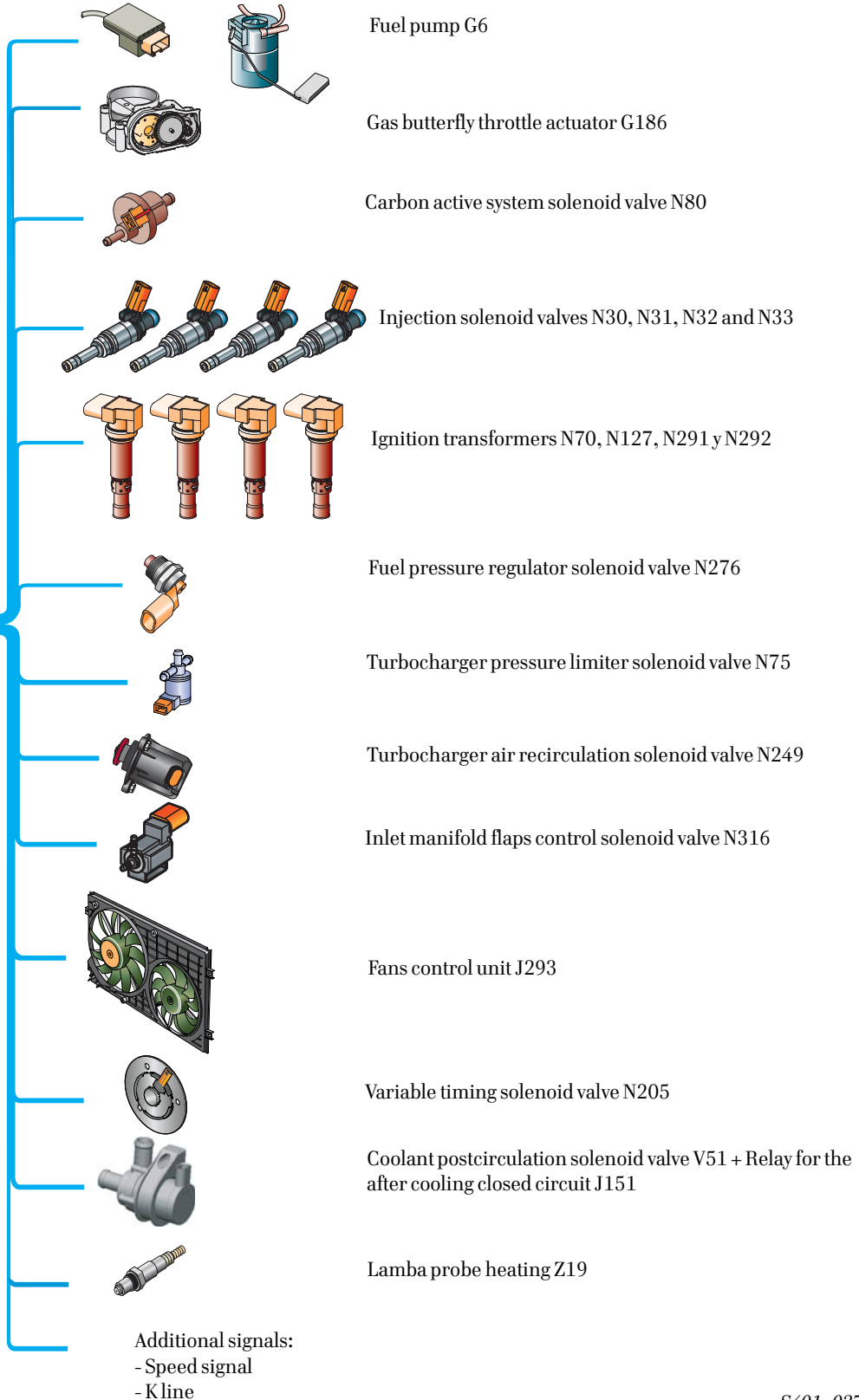

S401_037

Sensors and actuators

Air mass meter G70

The new air mass meter uses the “hot film with ebb” technique, and measures the air mass intake by means of a partial flow (bypass).

The engine control unit receives a modulated frequency digitalised signal. Once the frequency of the input signal is calculated, the engine control unit consults the intake air mass associated to that frequency in a memorised characteristic curve. The range of frequencies can oscillate between 1200 Hz for a kg/hr. air mass, up to 3900 Hz for a 640 kg/hr. air mass.

Replacement function

In the event of lack of signal from the air mass meter, the engine control unit will use the gas butterfly throttle position sensors G187 and G188.

Air temperature sensor G299

The 1.8l TFSI engine air mass meter G70 incorporates inside an air temperature sensor made up by an NTC type of resistor and an electronics in charge of converting the sensor's reading into a digital signal at the output of the sensor.

This sensor informs the engine control unit about the air temperature at the engine intake in order to calculate the volume of fresh air taken in.

Replacement function

In the event of lack of signal, the engine control unit uses the temperature value memorised during the last driving cycle. For safety, it activates the fans at maximum speed.

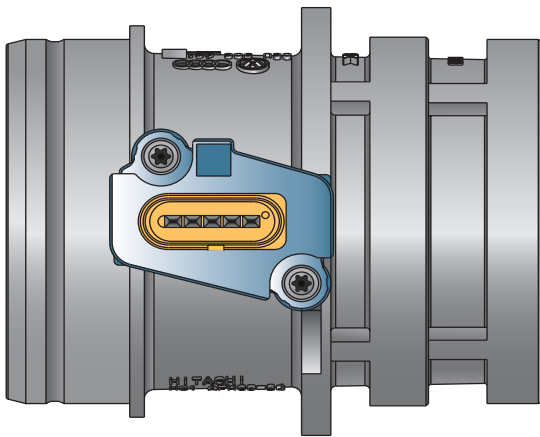
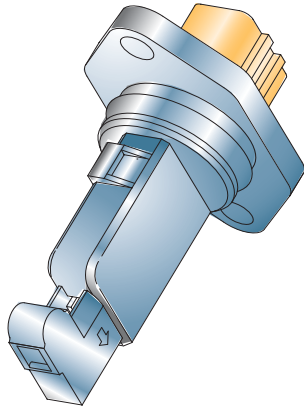

G70:

- 1 - Output signal
- 2 - GND
- 3 - Supply voltage

G299:

- 4 - NTC (-)
- 5 - NTC (+)

Output signal G70:

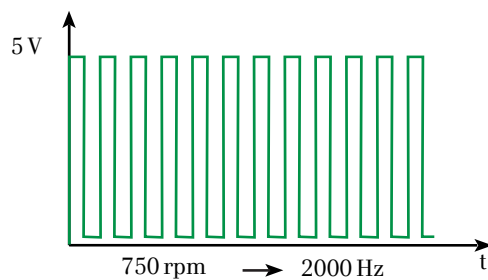

S401_038

Lamba sensor G39

A new feature of the MED 17.5 management system is the elimination of the continuous measuring lambda probe. The 1.8l TFSI engine is equipped with a conventional or stepped regulation lambda probe, between the pre-catalyst and the catalyst.

The function the continuous lambda probe used to carry out has been replaced by values memorised in the engine control unit. These values are the result of the tests carried out during the development phase of the engine.

The engine maintains the lambda mixture composition equal to one in all the engine performance modes, except in cold start.

The lambda probe Z19 heating is in charge of making the probe reach its operation temperature very fast.

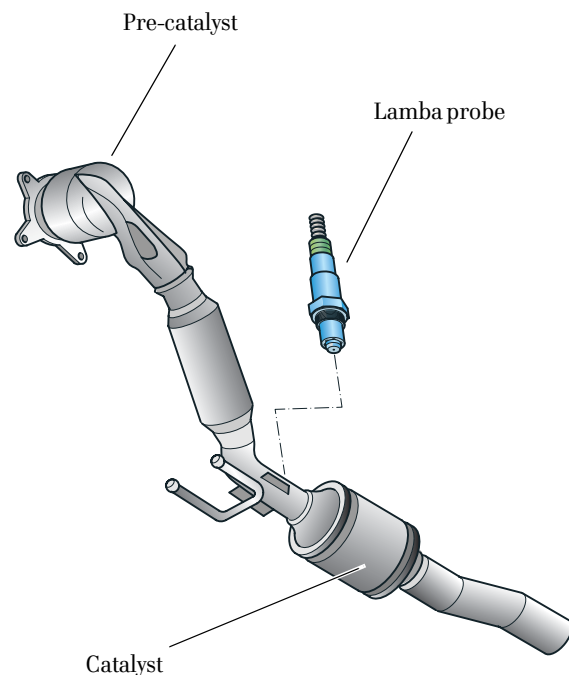

S401_039

Potentiometer for the inlet manifold flaps G336

It is placed at the end of the inlet manifold flaps activation shaft, on the timing side.

The potentiometer only informs about two positions, flaps open or closed, because the control unit does not take into account the intermediate positions.

The engine control unit uses this signal to know the state of operation of the guided intake system.

Replacement function

If the signal is not present, the engine control unit interrupts the energising of the inlet manifold flaps control solenoid valve N316, and leaves the flaps in the at rest position, that is, closed.

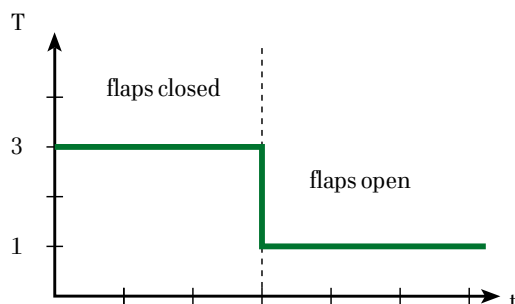
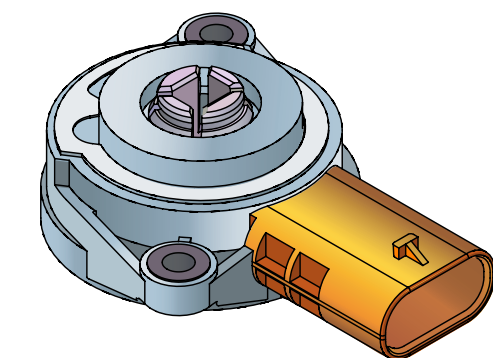

S401_040

Sensors and actuators

Injection solenoid valves N30 - N33

The new injectors used in the 1.8l TFSI engine have six fuel output drills and inject fuel in six conic jets at a 50° output angle (in the 2.0l TFSI engine the injection is carried out through a single drill and at a 10° output angle).

This new design allows for better mix preparation inside the combustion chamber.

These measures contribute to reducing hydrocarbons emissions, generating of soot, and oil dilution. Also, the tendency to knocking is also reduced.

The injectors, as with the previous direct injection engines, have been designed in order to carry out a double injection, at intake and at compression, in order to rapidly increase the temperature of the catalyst.

The mode of activation of the injectors has not been modified, they are energised at an approximate voltage of 65 volts.

Once the injector needle has lifted, it is enough to apply a pulse energising voltage of approximately 15 volts in order to keep it open.

Replacement function

In the event of a fault, the engine control unit detects the problem because of detecting ignition faults and cuts off any energising to it.

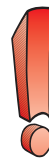

In the BZB engine the 6 injection drills are offset, which means a change of the injection cloud angle.

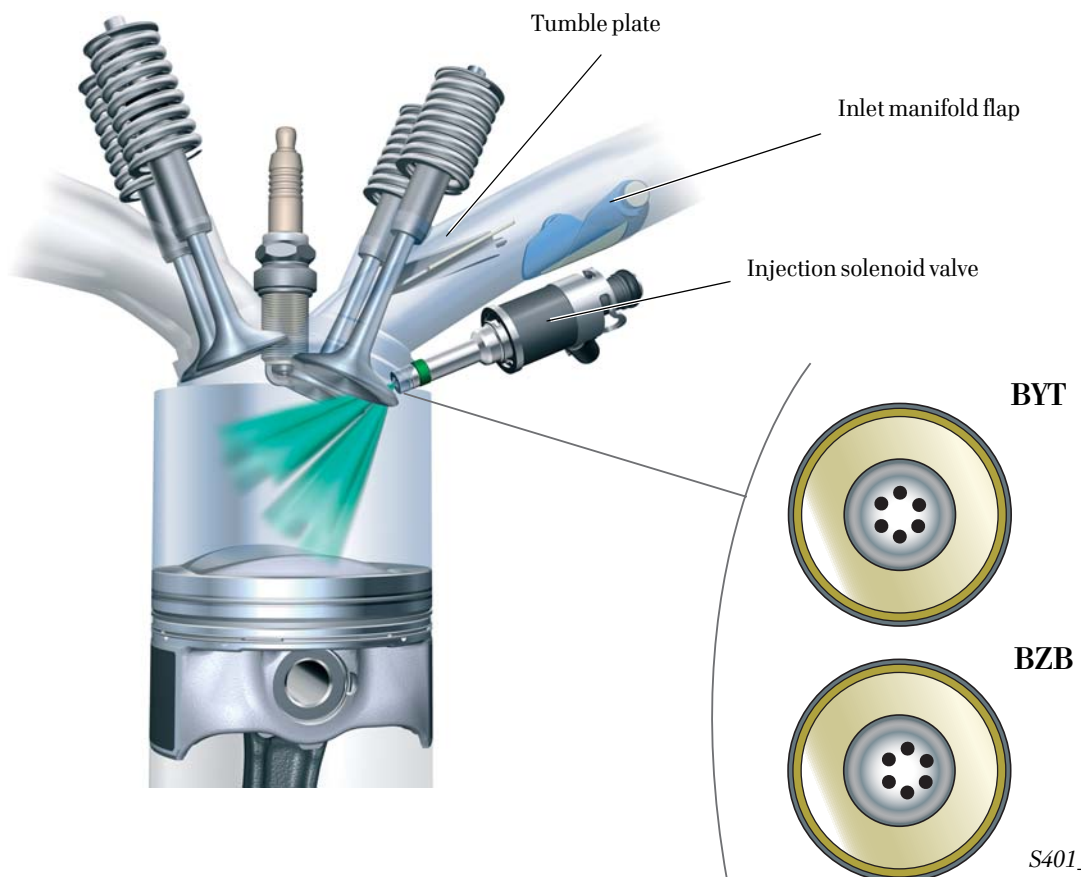

BYT

BZB

S401_041

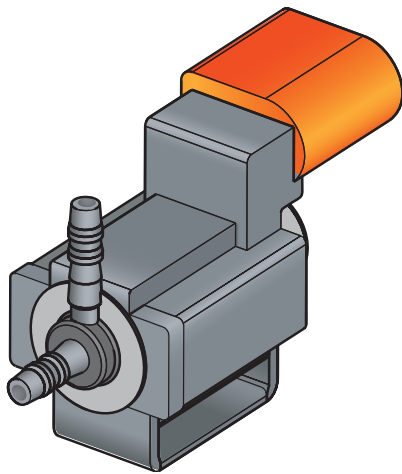

S401_042

Inlet manifold flaps solenoid valve N316

Placed on the inlet manifold, the engine control unit activates it with negative supply, when the revs sensor G28 informs that 3000 rpm has been surpassed.

Replacement function

In the event of a fault the inlet flaps remain closed, at rest position, and a drop in performance can be felt at over 3000 rpm.

Fuel pressure regulator solenoid valve N276

The engine control unit can energise the solenoid valve N276 at any moment during the piston's drive stroke. Duration of energising is minimum and remains invariable (< 10 ms), thus reducing electrical consumption. The engine control unit energises the solenoid valve by connecting it to earth.

The sooner the energising the larger the useful period of the drive stroke, and therefore, the higher the pressure in the distributor rail. If 200 bar pressure is overpassed the release valve opens to reduce it.

Replacement function

In the event of a fault, the pressure in the fuel distributor rail is equalised to the pressure in the fuel low pressure circuit, thus reducing the quality of the mix and generating engine faults.

If the energising signal is shorted to negative or if a constant current is applied to the fuel pressure regulator solenoid valve for over one second, an irreparable internal fault is generated.

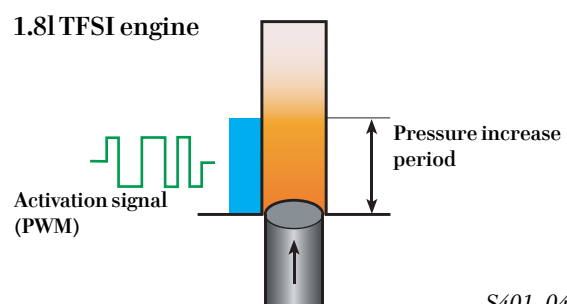
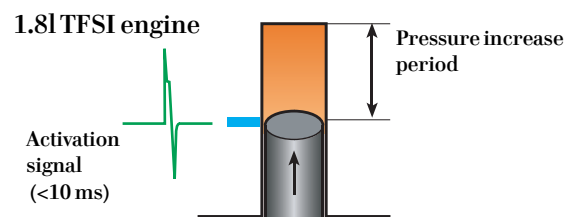
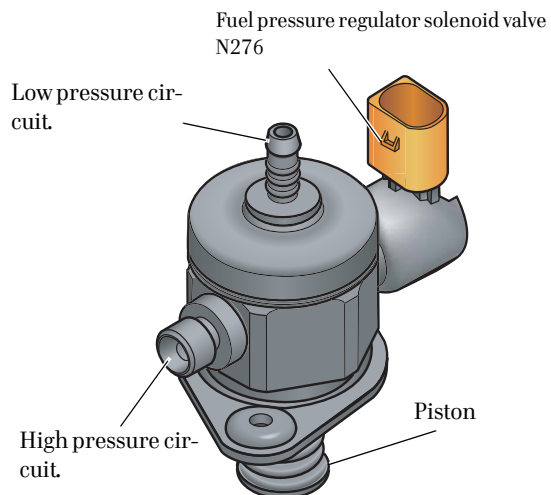

S401_043

Sensors and actuators

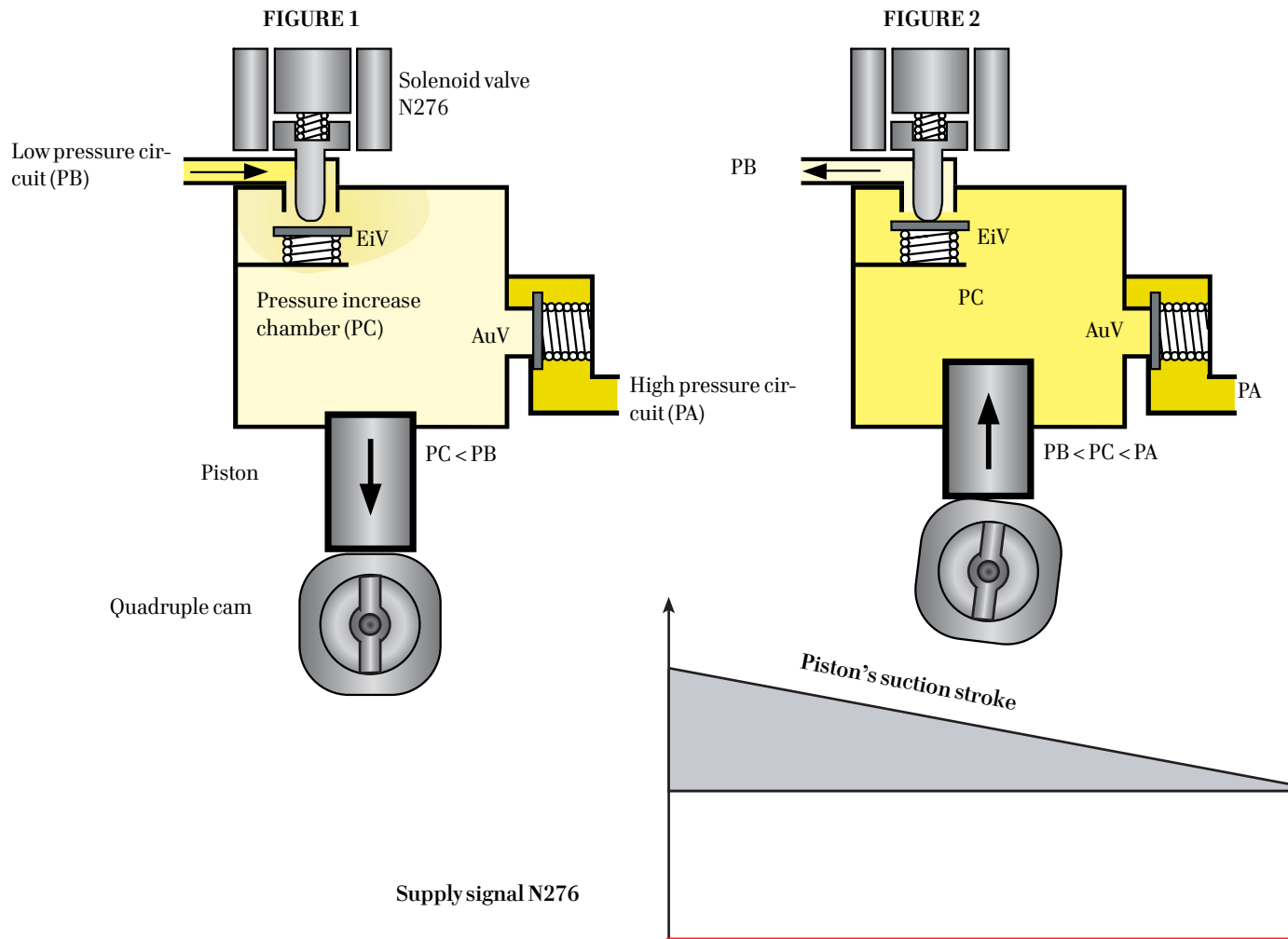

Energising system N276

The graph shows how the high pressure pump regulation works. Here, the complete upwards cycle of a cam is represented. This action takes place four times per every camshaft rotation. The lower diagram shows the pump piston movement and the energising of the solenoid valve N276.

The high pressure and also the amount of fuel are regulated by means of the fuel pressure regulator solenoid valve N276. The signal from the fuel pressure sensor G247 placed in the distributor rail is used as a measuring magnitude so that the engine control unit regulates the pressure in the distributor rail.

FIGURE 1

- Pump piston in intake stroke, fuel flows from the low pressure passage to the lifting chamber.
- N276 without any current being applied.
- The intake valve (EiV) is open, because the force of the spring is smaller than the force of the fuel pump G6 flow (less than 6 bar). The pressure inside the lifting chamber is regulated because of the existing vacuum.
- The output valve (AuV) is closed.

FIGURE 2

- Pump piston in drive stroke.
- N276 without any current being applied.
- EiV tends to close because of the pressure inside the chamber increases and overcomes the pressure in the low pressure circuit.

FIGURE 3

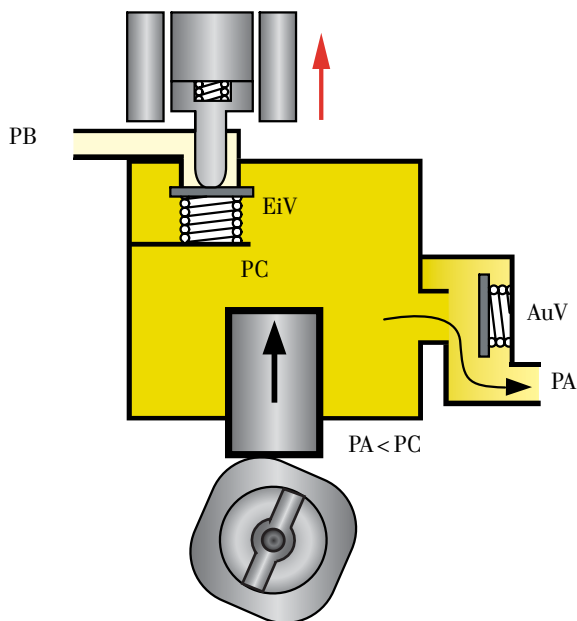
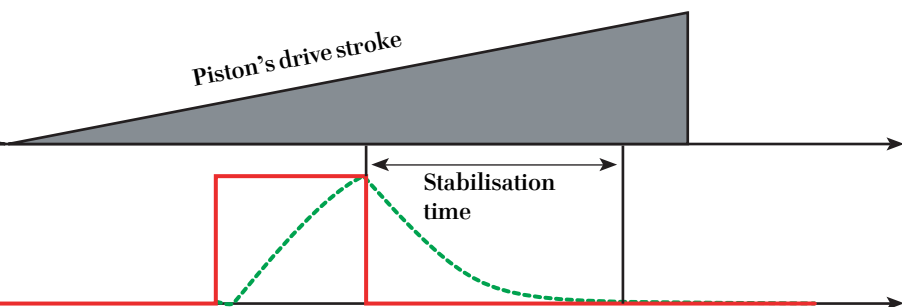
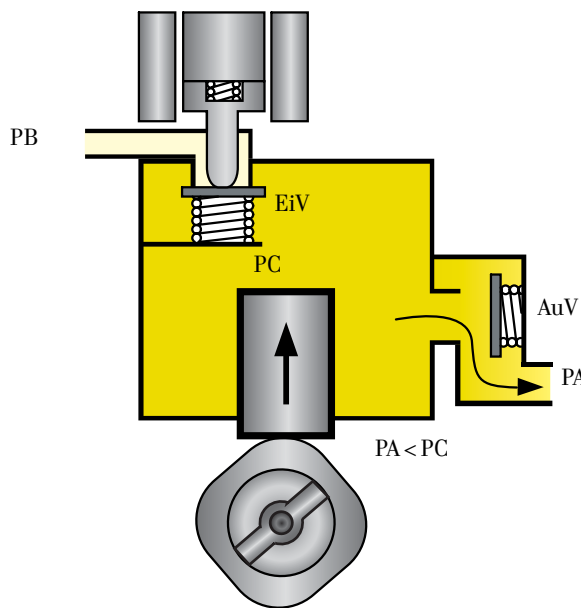

FIGURE 4



S401_044

However, the N276 holds it slightly open so that there is a small leak of fuel to the low pressure circuit. In spite of the piston generating a pressure increase inside, the leak of fuel does not allow for the pressure to overcome the pressure in the distributor rail thus guaranteeing that the AuV remains closed.

FIGURE 3

- Pump piston in drive stroke.
- The N276 gets a brief current pulse from the engine control unit.
- The N276 needle goes back and the EiV closes.
- Because of the upwards movement of the piston, the pressure in the lifting chamber increases immediately.
- As soon as the pressure inside the chamber over-

comes the pressure in the high pressure passage, the AuV opens and the pressure inside the fuel distributor rail increases.

FIGURE 4

- Pump piston in drive stroke.
- Fuel flows to the distributor rail until the piston begins its suction stroke.
- N276 without any current being applied.
- EiV closed until, in the suction stroke, the pressure in the lifting chamber is lower to the force of the spring of the N276.
- AuV open until, in the suction stroke, the lifting chamber pressure is lower than the pressure in the distributor rail.
- Next one cylinder injection takes place.

Variable Timing

The purpose of the variable timing is to achieve an optimum engine torque for the different engine running phases, improved running smoothness and quality of exhaust gases.

The variable timing acts on the inlet camshaft and can outphase it 30° , which is like saying 60° in relation to the crankshaft.

The control unit uses the signals from the air mass meter G70 and from the engine revs sensor G28, as basic signals for calculating the desired advance, and the coolant temperature sensor, G62, signal as a correction signal. The Hall sensor, G40, signal is used as feedback information in order to know the position of the inlet camshaft.

The position of the variator is defined by the variable timing solenoid valve, N205, which is controlled by the engine control unit with a fixed frequency and variable duty cycle period signal.

After engine stop, the variator is blocked at the delay position. This function is carried out by means of a locking pin under the pressure of a spring. The system unlocks when the oil pressure overcomes 0.5 bar.

The variator is made up by a rotor, a stator, an oil pressure distributor valve and a locking pin. The rotor is welded to the inlet cams and the stator activates the timing chain directly. The distributor valve is screwed to the camshaft anticlockwise. The new special tool T10352 is needed to remove the valve.

Depending on the magnetic field, the solenoid valve induced N205 pushes the distributor valve and opens the oil passage to the corresponding variator chamber.

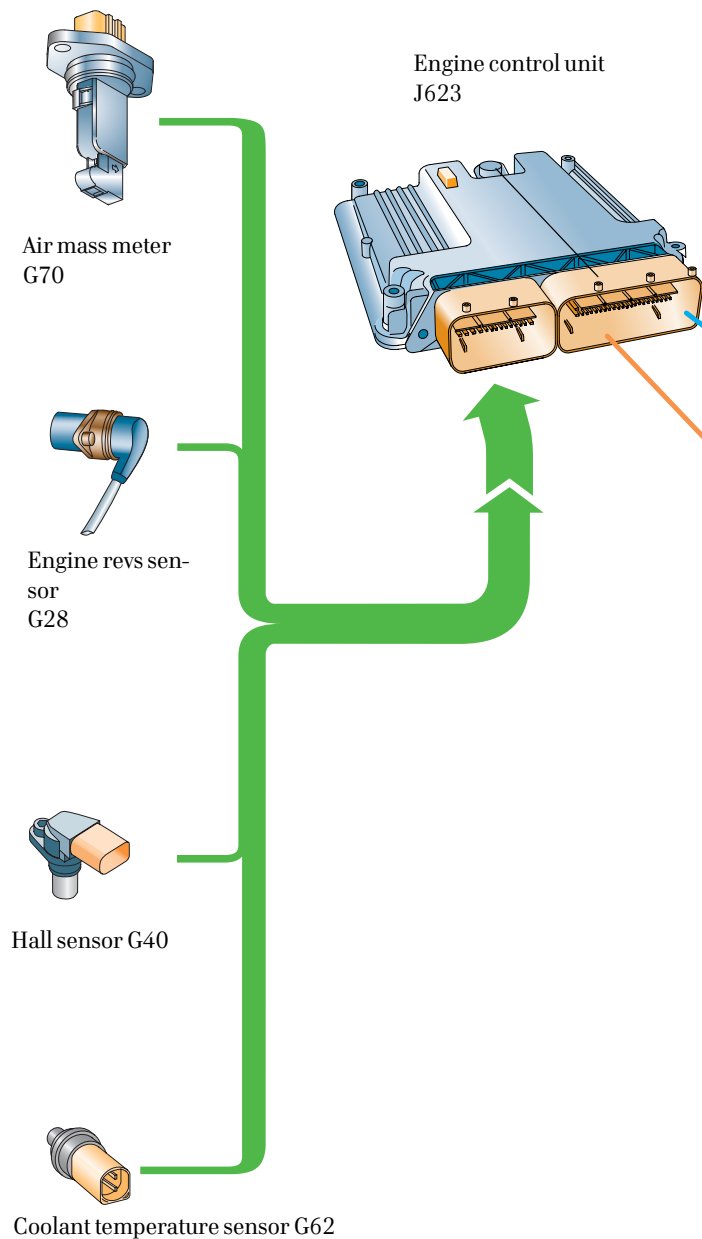

With the engine idling, or at revs below 1800 rpm and low load demand, the engine control unit does not energise the variable timing solenoid valve and the variator remains in the 'at rest' position.

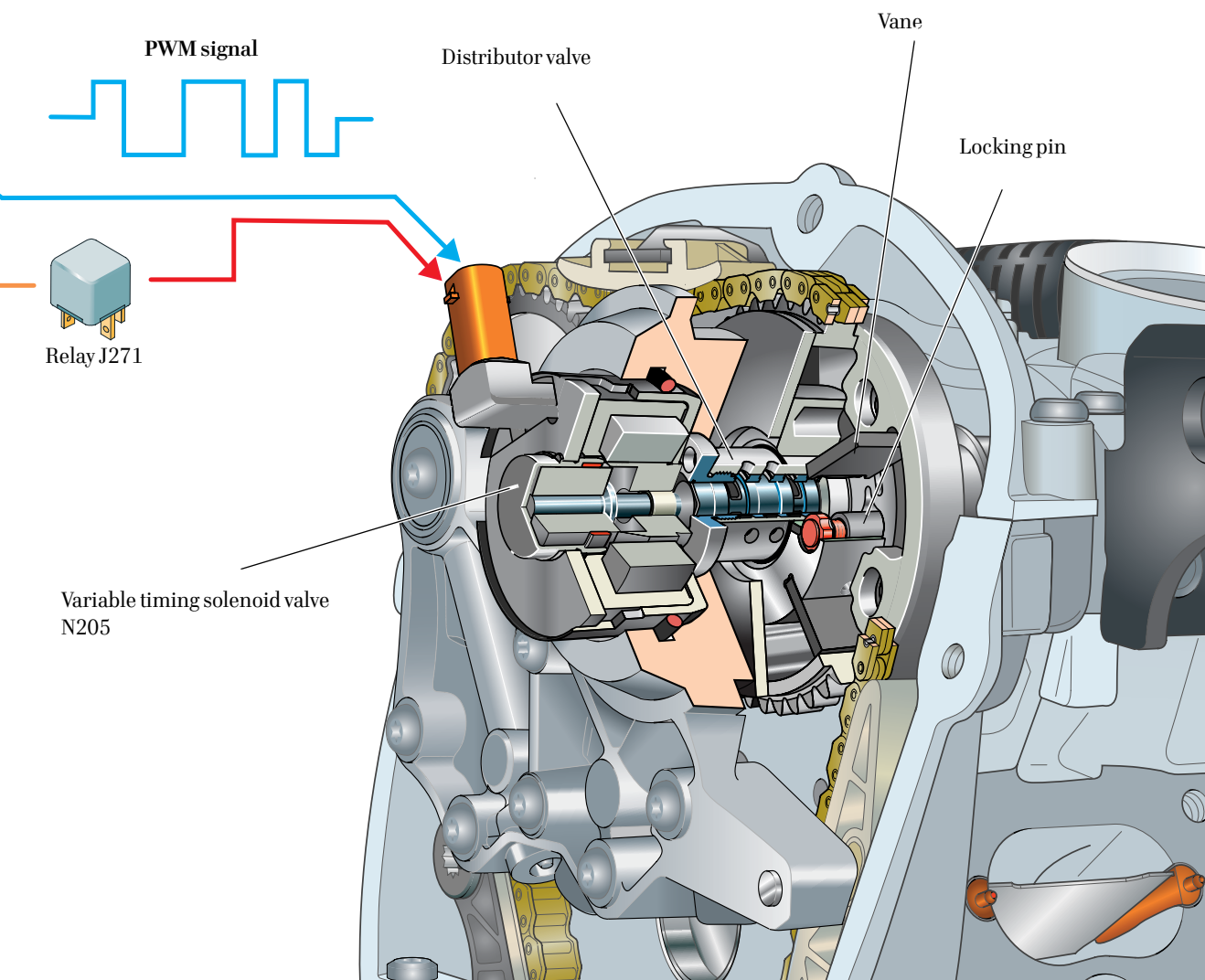

S401_045

When the engine is running at over 1800 rpm and with load demand, the control unit modifies the inlet camshaft position by advancing the moment of opening and closing the valves to optimise fill-up of cylinders.

The camshaft adjusting takes place by taking as a refer-

ence the family of features stored in the engine control unit.

In the event of a system fault, the camshaft remains in the delay position reducing the engine torque.

Functions wiring diagram

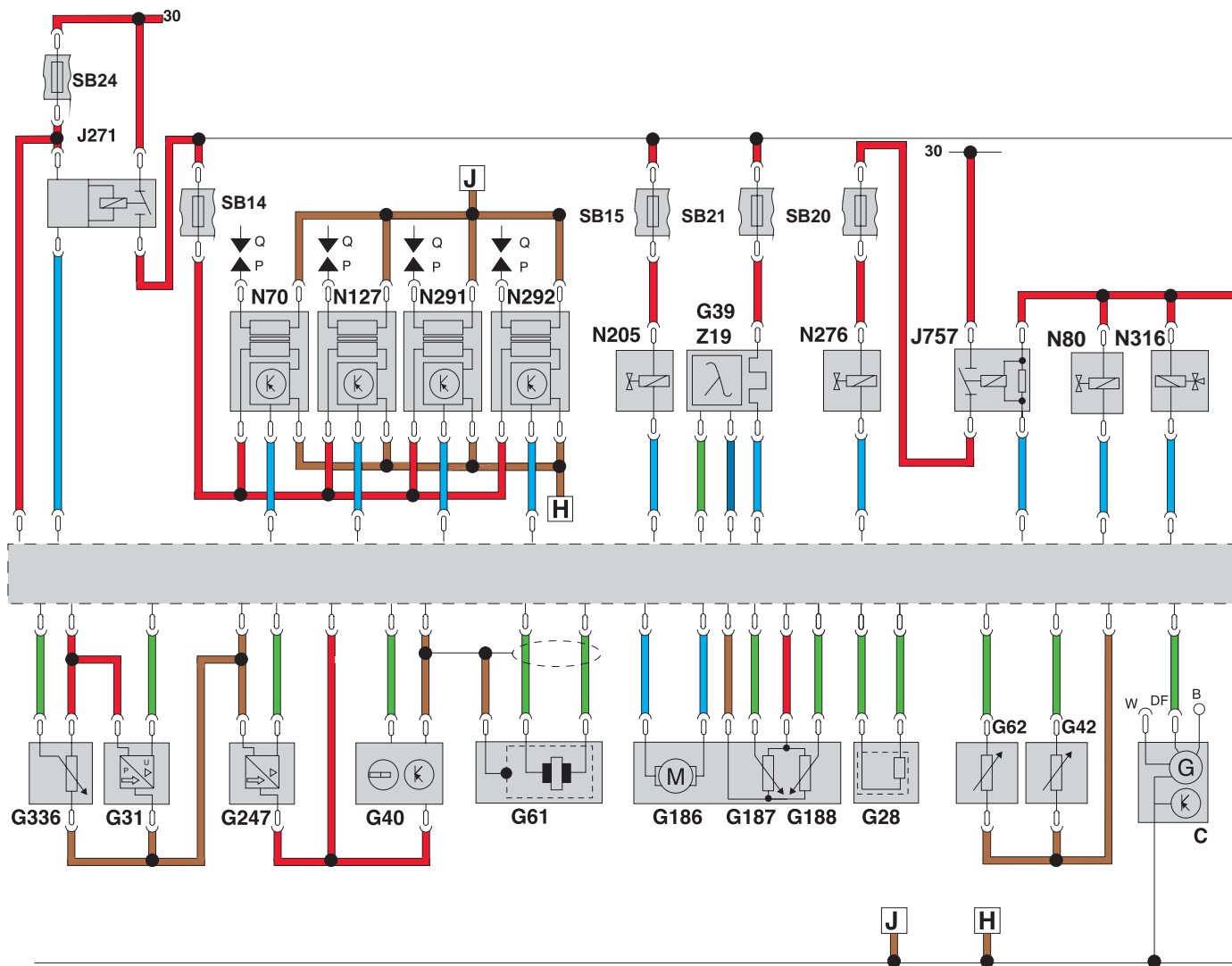

HEADING

C	Alternator	G188	Butterfly sensor 2
F/F63	Brake switches	G247	Fuel high pressure sensor
G	Gauger.	G299	Intake air temperature sensor 2.
G6	Fuel pump.	G336	Inlet manifold flap potentiometer.
G28	Engine revs sensor.	G476	Clutch pedal position sensor.
G31	Inlet manifold pressure sensor.	J104	ABS control unit.
G39	Lamba Probe.	J151	Relay for the after cooling closed circuit.
G40	Hall sensor.	J623	Engine control unit.
G42	Intake air temperature sensor.	J234	Airbag control unit.
G61	Knock sensor	J271	Supply relay.
G62	Coolant temperature sensor.	J285	Instrument panel control unit.
G70	Air mass meter	J293	Fans control unit.
G79	Accelerator position sensor 1.	J519	On-board network control unit.
G83	Coolant temperature sensor at the radiator output.	J527	Steering column control unit.
G185	Accelerator position sensor 2.	J533	Gateway
G186	Butterfly acuator	J538	Fuel pump control unit.
G187	Butterfly sensor 1		

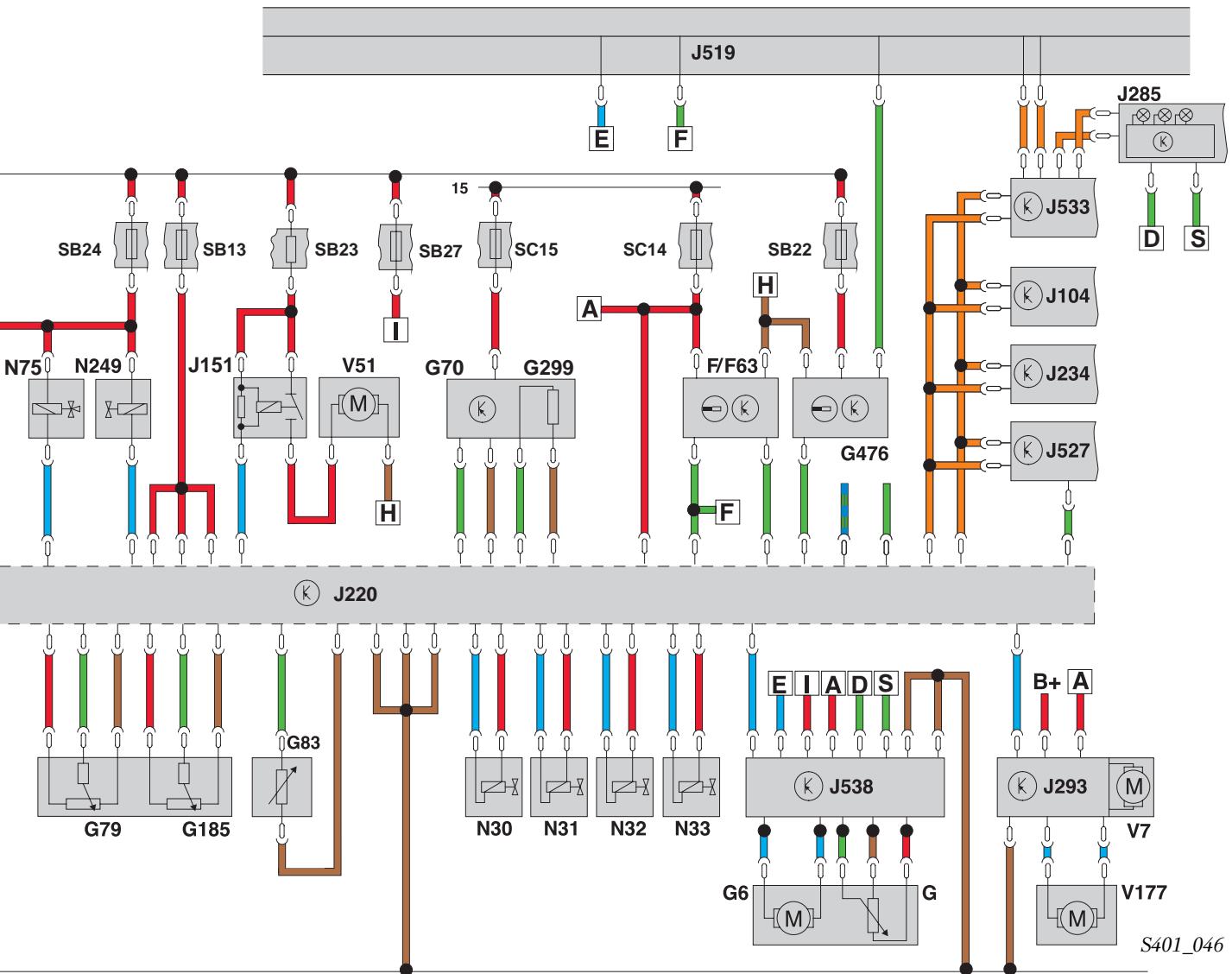

S401_046

- J757 Engine components supply relay.
- N30/33 Injection solenoid valves.
- N70/127/291/292 Cylinder 1 to 4 ignition transformers.
- N75 Over-boost pressure limiter solenoid
- .
- N80 Carbon active system solenoid.
- N205 Variable timing solenoid valve.
- N249 Turbocharger air recirculation solenoid valve.
- N276 Fuel pressure regulator solenoid valve.
- N316 Inlet manifold flaps control solenoid valve
- V7 Main fan for the coolant.
- V51 Coolant post-circulation pump.
- V177 Secondary fan for the coolant.
- Z19 Lamba probe heating.

COLOUR CODING

- █ Input signal.
- █ Output signal.
- █ Positive supply.
- █ Earth.
- ██ K diagnosis line.
- █ CAN-Bus signal.

ADDITIONAL SIGNALS

- GRA on/off speed regulator.
- Speed signal.

Glossary

CAN-Bus

Controller Area Network

It is a communication protocol made up by two intertwined wires that link up the different control units.

This is how a great deal of information is shared among the vehicle control units by means of messages sent at a high speed and with a very reduced transmission error percentage.

Catalyst

It is an exhaust gases cleaning element containing metals (mainly Platinum and Rhodium) that enhance reaction between the exhaust gases and the oxygen in the air in order to turn them into less polluting substances. Petrol engines incorporate three way catalysts, which as well as oxidizing (adding oxygen) can reduce (remove oxygen) certain exhaust gases. Normal running temperature of a catalyst is approximately 800°C, and cannot work with leaded petrol, because lead builds up on the catalyst components and cancels out its operation.

Closed-deck

A technique by means of which the cylinder liners are firmly cast to the block.

Crossed flow

Cylinder head structure that allows the flow of inlet gases and exhaust gases passage through opposite sides, which improves cylinder fill-up.

FSI

Fuel Stratified Injection

A technique used in the VW Group engines to inject fuel at a pressure of over 100 bar directly into the combustion chamber.

Grey cast

Alloy made of iron, carbon, silicon, manganese, sulphur and phosphorous, in different amounts. The main advantages are: easiness of machining, resistance to wear from friction, resistance to the thermal stroke and to corrosion. This alloy is widely used in manufacturing of engine blocks.

Hall

The Hall effect takes place when a current is applied to certain type of semiconductor and it is submitted to a magnetic field. Depending on the variation of this magnetic field a voltage difference is generated between the pins of the semiconductor.

Emission standards EU 4

European Union standard for manufacturers to reduce the exhaust gases emissions thresholds and the polluting particles from the combustion engines. Number 4 indicates that it is the fourth standard implemented. Obviously, every new standard is more restrictive by nature.

NTC

Negative Temperature Coefficient

It is a resistance whose ohm rate decreases when the component's temperature rises. This type of resistances are generally used as temperature sensors.

Octane

Measure unit for the anti-firing capacity of fuels in order to avoid the from detonating and exploding before the optimum momentum inside the combustion chamber. The higher the octane rating, the higher the capacity for obtaining all the useful energy from the fuel.

Ohm

Electrical resistance unit that measures the opposition from a conductor element when an electrical current goes through it.

Polyamid

Synthetic resin with the following main features: high fusion point, highly crystalline, high torsion, capability of being directed by cold stretching, and good chemical resistance. Because of their features, polyamids are used in several components which are close to the engine.

PTC

Positive Temperature Coefficient

It is a resistance whose ohm rating decreases when the component's temperature rises. These resistances are generally used as heating elements and as temperature sensors.

Compression ratio

An engine's compression ratio is the quotient between the volume inside the cylinder when the piston is at BDC (bottom dead center) and the volume inside the cylinder when the piston is at TDC (top dead center). In a petrol engine this value is generally 10:1; in a diesel engine it is approximately 18:1.

Analogical signal

A signal that represents the evolution of a magnitude in a continuous time manner. It is used, for instance, for defining the electrical signals where the information is interpreted according to the variation of a certain magnitude (e.g.: voltage or resistance).

Digital signal

A digital signal refers to physical magnitudes limited to only taking limited discrete values. For instance, the resistance of a switch can only take two values: 0 (very small resistance) or 1 (very high resistance). The combination of values (0-1) configures ciphered information packs that can be interpreted by a processor or a control unit.

Brake servo

A system used for reducing the force the driver has to apply to reduce the vehicle's braking distance to its minimum. The most widely used brake servo makes use of the vacuum in the inlet manifold of petrol engines, whilst in diesel engines a vacuum pump is used. Other types of brake servos are hydraulic, electrical or compressed air.

EOBD System

European On Board Diagnose System

System for diagnosis and control of the exhaust gases polluting emissions that all the vehicles registered from the year 2005 in the European Union must comply with in 2005. The EOBD is standard for all vehicles and at the same time it is a check up and control point for the inspection authorities.

Overboost

An overboosted engine has a pressure in the inlet manifold which is higher than atmospheric pressure, achieved by using a turbine or blower fan.

Lambda Probe

A sensor that measures the existing oxygen ratio in the exhaust gases. It is part of a regulation system, its main component being the engine control unit that is in charge of making the best air and petrol mixture in order to prevent polluting emissions in the exhaust gases as a result of poor combustion.

Fracture joint

Cold fractured conrod big ends during manufacturing, which improves the contact surfaces of both contact areas.

Check your knowledge

1. Which of the following systems is not present in the 1.8l TFSI engine?

- a) Counter-rotating balance shafts.
- b) Inlet manifold guided intake.
- c) Exhaust variable timing.
- d) System for eliminating the blow-by and fuel tank vapours.

2. Point out which of the following statements about the BYT engine block and sump is false.

- a) The counter-rotating balance shafts are integrated in the engine block, just above the crankshaft.
- b) The upper sump, made of aluminium alloy, has the oil pump screwed onto its lower parts.
- c) The three central half-shells of the engine mounting are screwed onto the block sideways as well as vertically.
- d) The conrod big end is trapezoidal, to share out the forces better, and the sleeve is mad of bronze.

3. Point out which of the following statements about the BYT engine cylinder head is false.

- a) It has eight intake and eight exhaust valves.
- b) There is a quadruple cam on the intake camshaft.
- c) The toothed crown gear for the Hall sensor G40 is placed in the centre of the inlet camshaft.
- d) The BYT engine three-layer cylinder head gasket is not like the one on the BZB engine.

4. Indicate the order of removal of the following parts before you can remove the chain from the camshafts.

- a) Polyamid side cover.
- b) Variable timing solenoid valve N205.
- c) Oil pressure distributor valve.
- d) Oil distributor mounting.

5. Point out when are the guided intake system flaps are completely open.
- a) When the engine is idling.
 - b) During cold start.
 - c) When the engine is running at over 3000 rpm.
 - d) When the engine temperature is over 80° C.
6. Point out which of the following components does not belong to the BYT engine blow-by vapours elimination system.
- a) Pressure regulator valve.
 - b) Thick oil particles separator.
 - c) Cyclone separator.
 - d) Carbon active system solenoid valve N80.
7. What is the existing oil pressure in the engine lubrication circuit when the engine is running?
- a) Approximately 11 bar.
 - b) Approximately 3.5 bar.
 - c) Approximately 0.5 bar.
 - d) It varies between 3.5 and 11 bar, depending on the engine revs. d) It varies between 3.5 and 11 bar, depending on the engine revs.
8. Point out which of the following statements about the fuel supply system is false.
- a) The release valve, placed at the high pressure pump is rated at 150 bar.
 - b) The fuel pressure in the high pressure circuit can vary between 50 and 150 bar.
 - c) The high pressure pump is activated by a triple cam placed on the intake camshaft.
 - d) The engine control unit energises the fuel pressure regulator solenoid valve N276 after every injection.

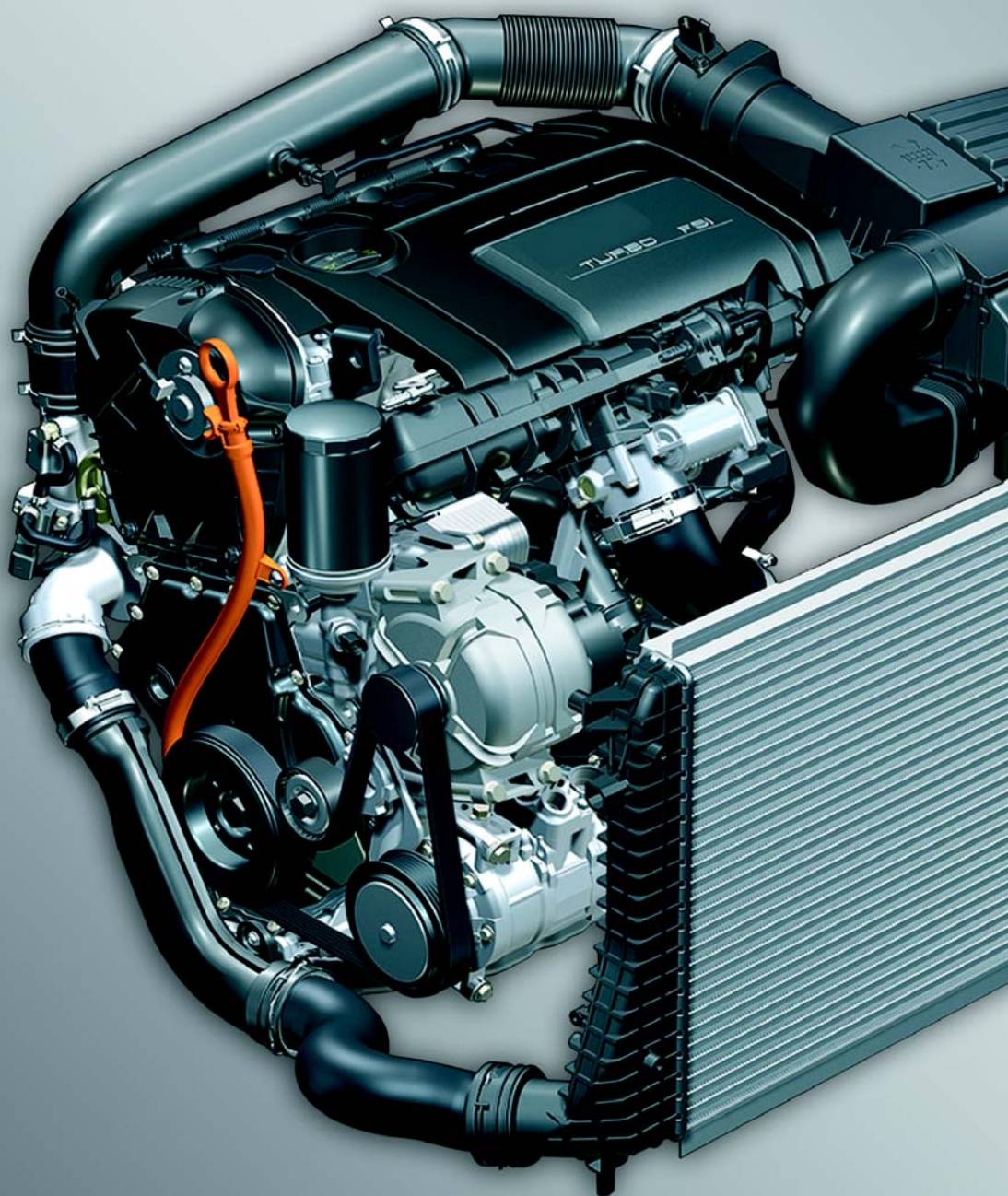

© SEAT S.A., Barcelona
All rights reserved. Subject to technical changes.
K00.2804.01.60 Technical version 09.2007
SEAT S.A.
Customer Service
Autovía A2 Km.585
E-08760 Martorell (Barcelona)

⁷ This paper has been manufactured with chlorine free starched cellulose.