



Self-study Programme 389

ParkAssist

Design and function



Driver assist systems are developed to relieve the burden on drivers due to the increasingly dense traffic and the flood of information that they have to deal with. These aids support drivers in certain driving situations or take over driving procedures either completely or partly.

As computer performance rises and the production costs of electronic components fall, it is not surprising that Volkswagen is offering an increasing number of more powerful assist systems.

The new ParkAssist from Volkswagen is one example of the increased capability of assistance systems. ParkAssist actively helps the driver when reversing into parallel parking spaces.

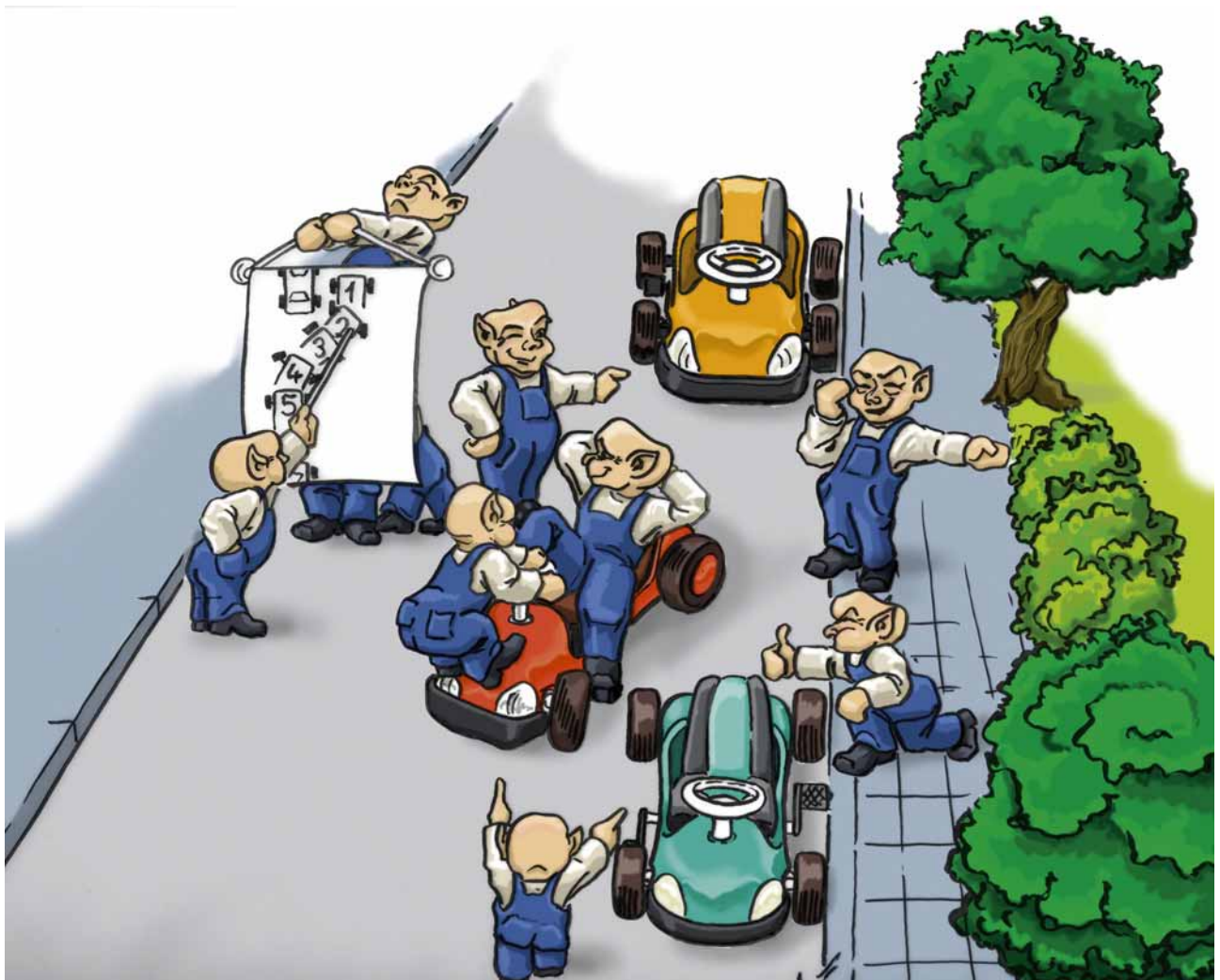

S389_020

NEW









Warning Note



**The self-study programme shows the design and function of new developments.
The contents will not be updated.**

For current testing, adjustment and repair instructions, refer to the relevant service literature.



Overview	4	
Design	6	
Overview of system components and their locations	6	
System schematics	8	
Electromechanical power steering	10	
Function of ParkAssist	12	
Parking procedure	12	
Overview of activation conditions	19	
Abort criteria and system messages	20	
Electrical components	22	
Sensors	22	
Actuators	26	
System control	27	
Functional diagram	28	
Service	30	
Test Yourself	31	

Overview



ParkAssist from Volkswagen

This assist system is an active helper when you reverse into parking spaces. This development is based on the park distance control system that uses ultrasound sensors and an acoustic warning to help the driver judge the distance from other parked cars or obstacles.

Further development stages for this kind of driver assist system are, for example, the reversing camera and the optical parking system that not only detects an obstacle in front of or behind the vehicle, but also obstacles position in the scanning area. In all these systems, the vehicle is still steered by the driver. However these systems simply help the driver judge and determine the area around the vehicle.

ParkAssist not only includes this surround scan, it also automatically controls the steering while the car is reversed into the parking space. The driver simply operates the accelerator, clutch and brake pedals. The driver can, however, take over control of the steering at any time and end the automatic parking procedure.

The system can reverse into parking spaces on both the right-hand and left-hand side of the road, for example on one-way streets.

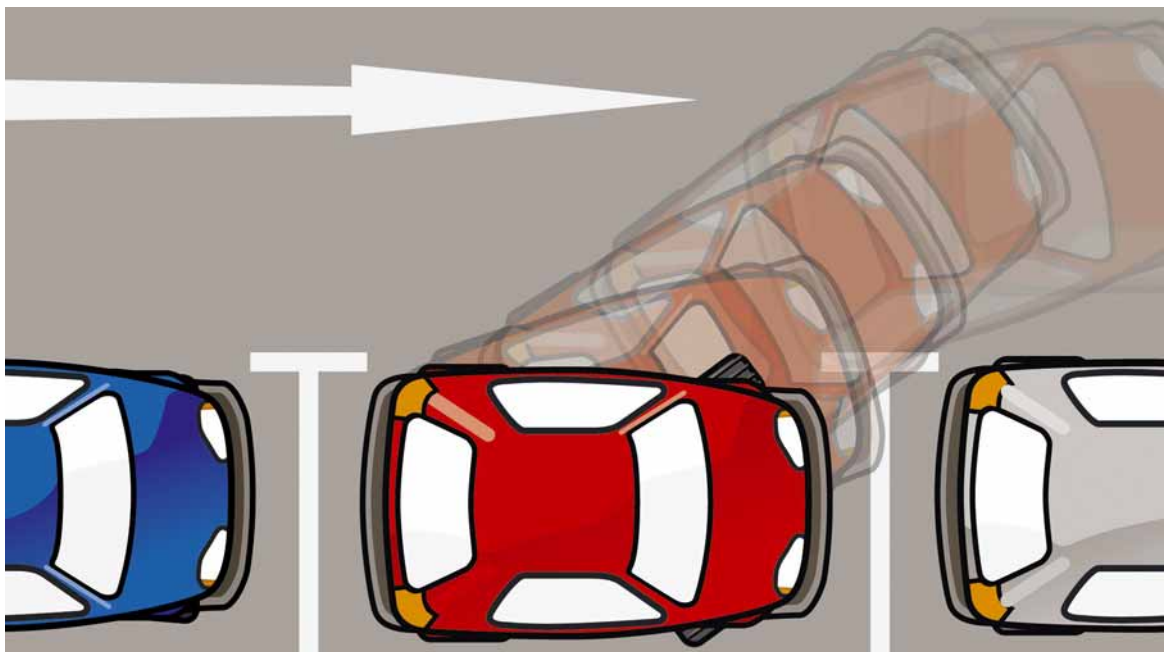

S389_019



Important note

ParkAssist cannot replace the driver's attentiveness.

The drivers are still legally responsible for their vehicle. If they notices a risk that pedestrians, other vehicles or objects could be damaged or if they are uncertain of the risk, they will need to react accordingly and stop the vehicle ending the function.



System requirements

A vehicle equipped with ParkAssist has the following technical requirements:

- electromechanical power steering.
- an ESP brake system.

Distinguishing between the park distance control and parking steering function

ParkAssist has two functions:

- The PDC park distance control system that is also known as the parking aid system.
- the parking steering function for the active parking process.

PDC park distance control system



S389_013

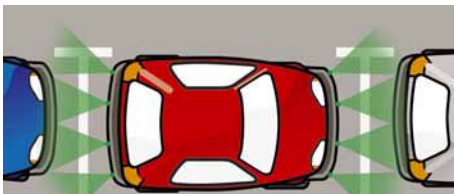

S389_024

PDC uses four ultrasound sensors at the front and four at the rear to measure the distance from objects in front of and behind the vehicle. If the vehicle reaches a specific distance from this object, there is an acoustic warning.

If the vehicle is only equipped with the parking aid, the parking aid control unit J446 will control the PDC function.

It is normally fitted in the boot.



If a vehicle is already equipped with a PDC system, it will not normally be possible to retrofit the parking steering function.

Parking steering function



S389_014

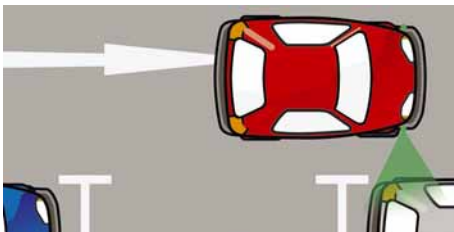

S389_026

In addition to the PDC sensors, the ParkAssist system also has an ultrasound sensor on each side of the vehicle at the front to search the areas alongside the vehicle for a parking space.

Design

Overview of system components and their locations

ParkAssist will be introduced with the Touran 2007.

The illustration adjacent will provide you with an overview of the locations of the components that are required to carry out the PDC and parking steering functions of the ParkAssist system.

The control unit for parallel parking assist J791 is installed to the left of the steering column. It controls the park distance control and the parking steering function and is networked to the drive CAN data bus.

If a vehicle is equipped with ParkAssist, there will be no parking aid control unit.

There may be different locations in the different vehicle types due to the varying space available particularly with control units.



Therefore make sure you read the latest repair and service literature for the various vehicle types.

Parking aid button
Parking assistant steering button

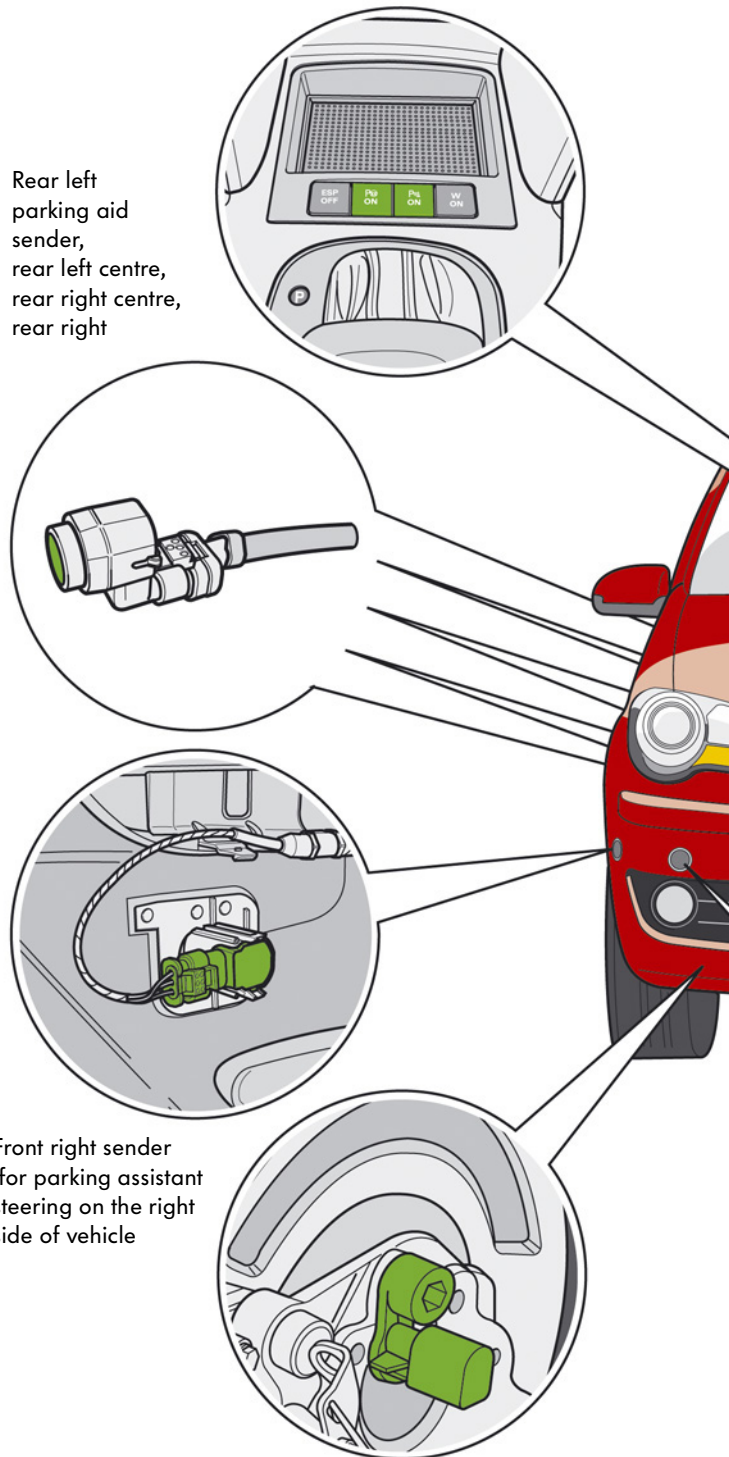

Rear left parking aid sender, rear left centre, rear right centre, rear right

Front right sender for parking assistant steering on the right side of vehicle

Wheel speed sensors, example front right



Turn signal switch

Trailer detector control unit*

Parking aid warning buzzer

Control unit for parallel parking assist

Braking system ABS and ESP

S389_002

Front left parking aid sender, front centre left, front centre right, front right

Electromechanical power steering

Front left sender for parking assistant steering on the left side of vehicle

* optional depending on vehicle equipment

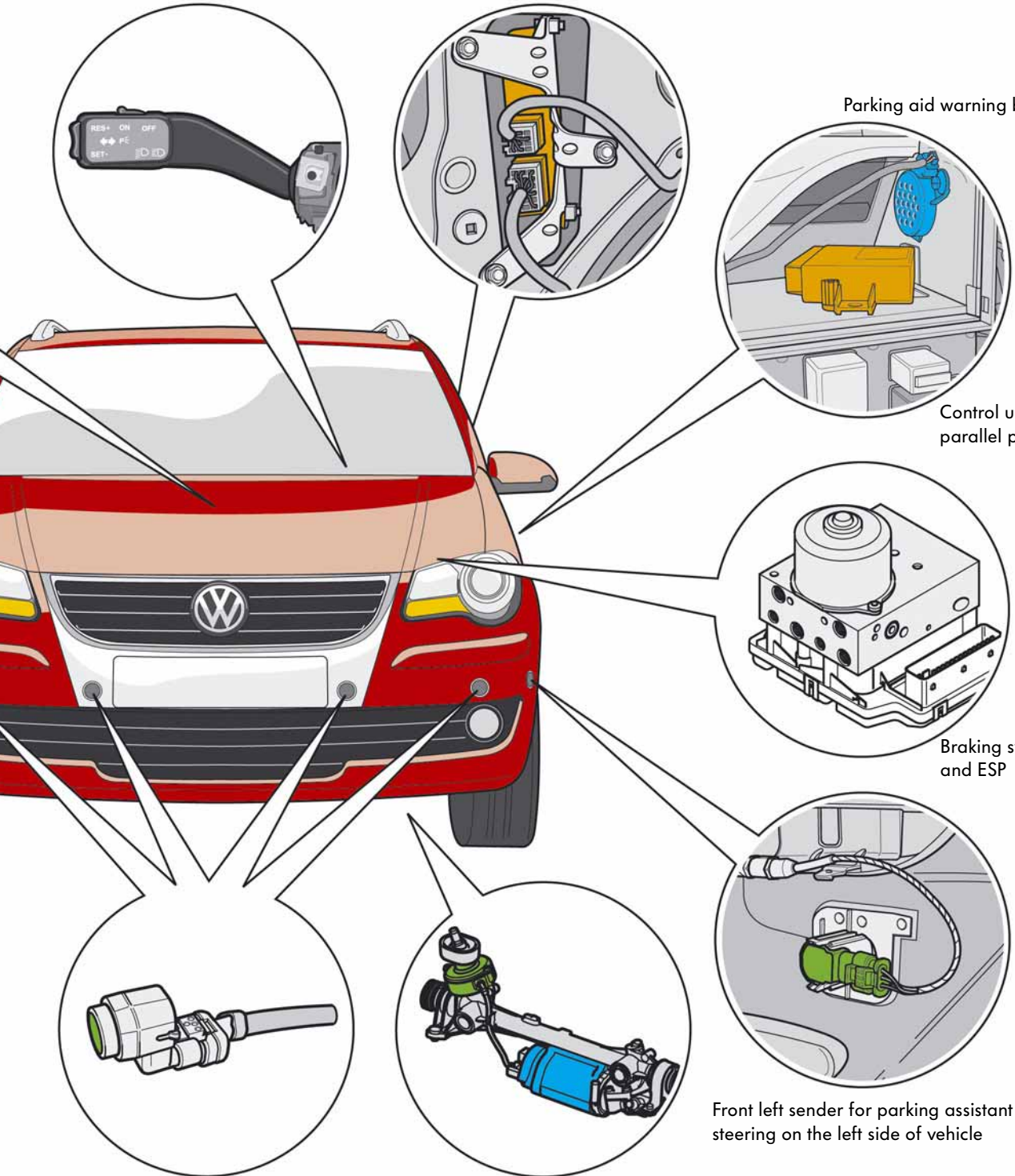

Design

System schematics

The ParkAssist system is an example of the interaction of various vehicle subsystems via the CAN data bus system to achieve a more complex function like, the parking steering function.

The following subsystems are involved in addition to the parking steering assist:

- the electromechanical power steering
- the braking system with ABS and ESP
- the engine and gearbox management
- the dashboard and steering column electronics
- the trailer detection (if installed)

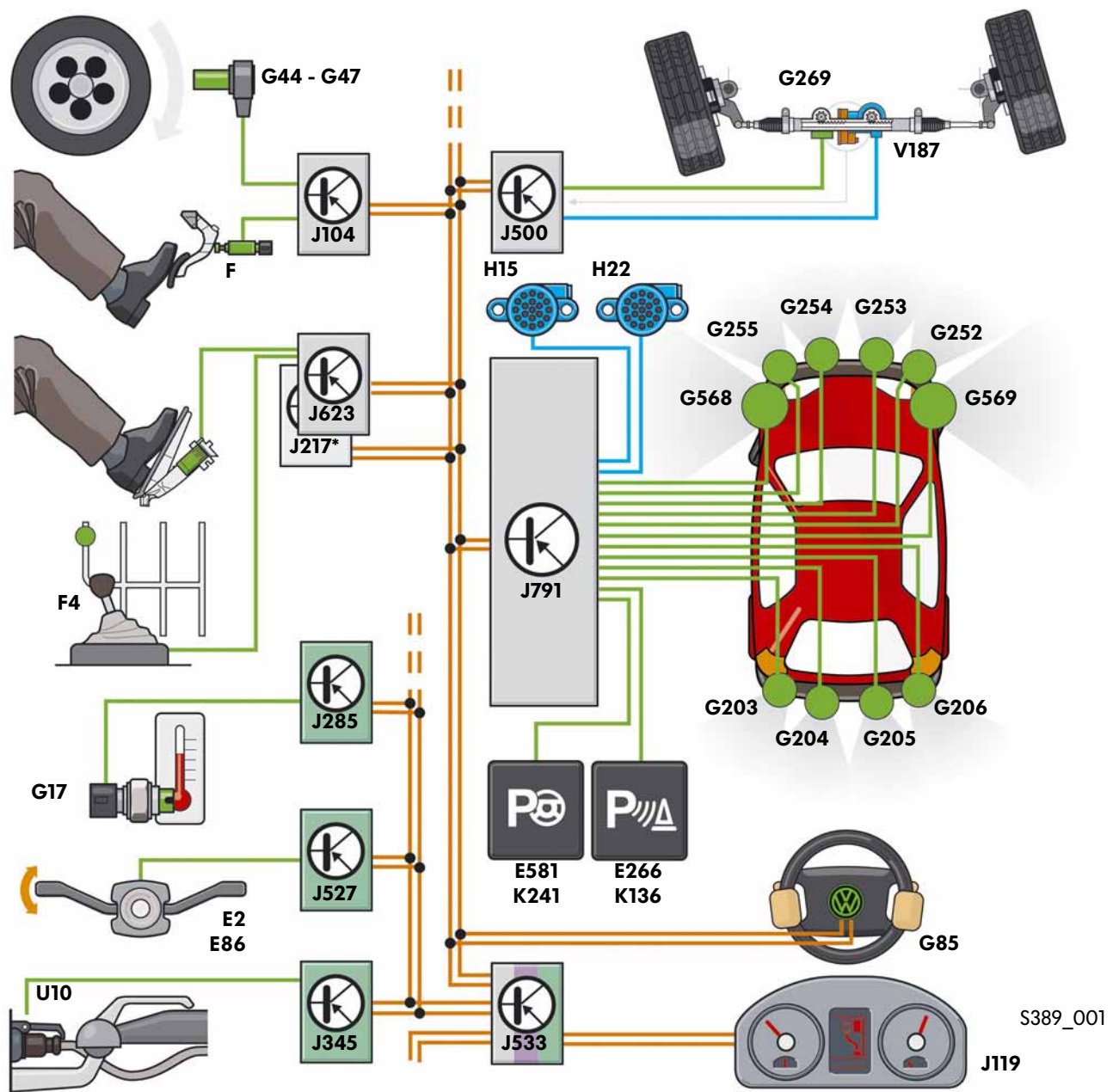

The following components of the aforementioned vehicle systems work together in the parking steering assist function:

ParkAssist

E266	Parking aid button
E581	Parking assistant steering button
G203	Rear left parking aid sender
G204	Rear centre left parking aid sender
G205	Rear centre right parking aid sender
G206	Rear right parking aid sender
G252	Front right parking aid sender
G253	Front centre right parking aid sender
G254	Front centre left parking aid sender
G255	Front left parking aid sender
G568	Front left sender for the parking assistant steering on left side of vehicle
G569	Front right sender for the parking assistant steering on right side of vehicle
H15	Rear parking aid warning buzzer
H22	Front parking aid warning buzzer
J791	Control unit for parallel parking assist
K136	Parking aid warning lamp
K241	Warning light for parking assistant steering

Electromechanical power steering

G269	Steering moment sender
J500	Power steering control unit
V187	Electromechanical power steering motor

Braking system

G44	Rear right speed sensor
G45	Front right speed sensor
G46	Rear left speed sensor
G47	Front left speed sensor
G85	Steering angle sender
J104	ABS control unit

Engine and gearbox management

F	Brake light switch
F4	Reversing light switch
J217*	Automatic gearbox control unit
J623	Engine control unit

Dash panel and steering column electronics







E2	Turn signal switch
E86	Multifunction display call-up button
G17	Ambient temperature sensor
J119	Multifunction display
J285	Control unit with display in dash panel insert
J527	Steering column electronics control unit
J533	Data bus diagnostic interface

Trailer detection**

J345	Trailer detector control unit
U10	Trailer socket

* only automatic vehicles

** only vehicles with tow bar and trailer detection

	Drive CAN data bus
	Convenience CAN data bus
	Infotainment CAN data bus
	Sensor, input signal
	Actuator, output signal
	CAN data bus line



Design

Electromechanical power steering

Electromechanical power steering is one of the main requirements for installing ParkAssist.

It allows the control unit for parallel parking assist to steer actively and automatically using the electrical drive for the power steering.

The following section will provide you with an overview of the design and function of the electromechanical power steering.



You will find more detailed information in self-study programme no. 317 "The Electromechanical Power-Assisted Steering with Double Pinion".

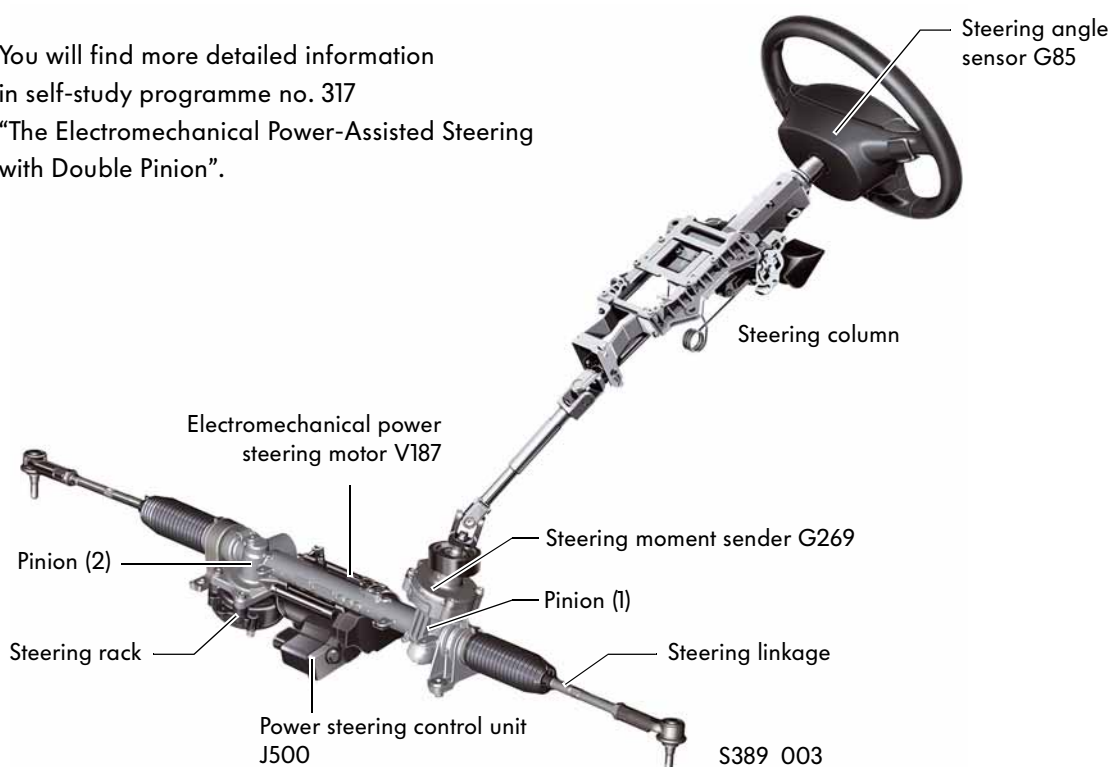

The electromechanical power steering is an alternative to hydraulic power-assisted steering. It comprises of the steering rack with an electromechanical power steering motor, the steering moment sender and the power steering control unit. One special feature of this power steering system is the double pinion in the steering mechanism. One pinion (1) is used to transfer the rotary movement of the steering wheel to the steering linkage. A torque sensor detects the steering moment that is applied by the driver.

The second pinion (2) transfers the drive power of the electric motor via the steering rack to the steering linkage.

The electromechanical power steering control unit is on the electric motor itself meaning no complex wiring is required. The control unit is informed about the position of the steering wheel and the speed at which the driver turns the steering wheel by the steering angle sender. It sends its data directly via the drive train CAN data bus and is also used, for example, by the ESP control unit.

Steering assist procedure

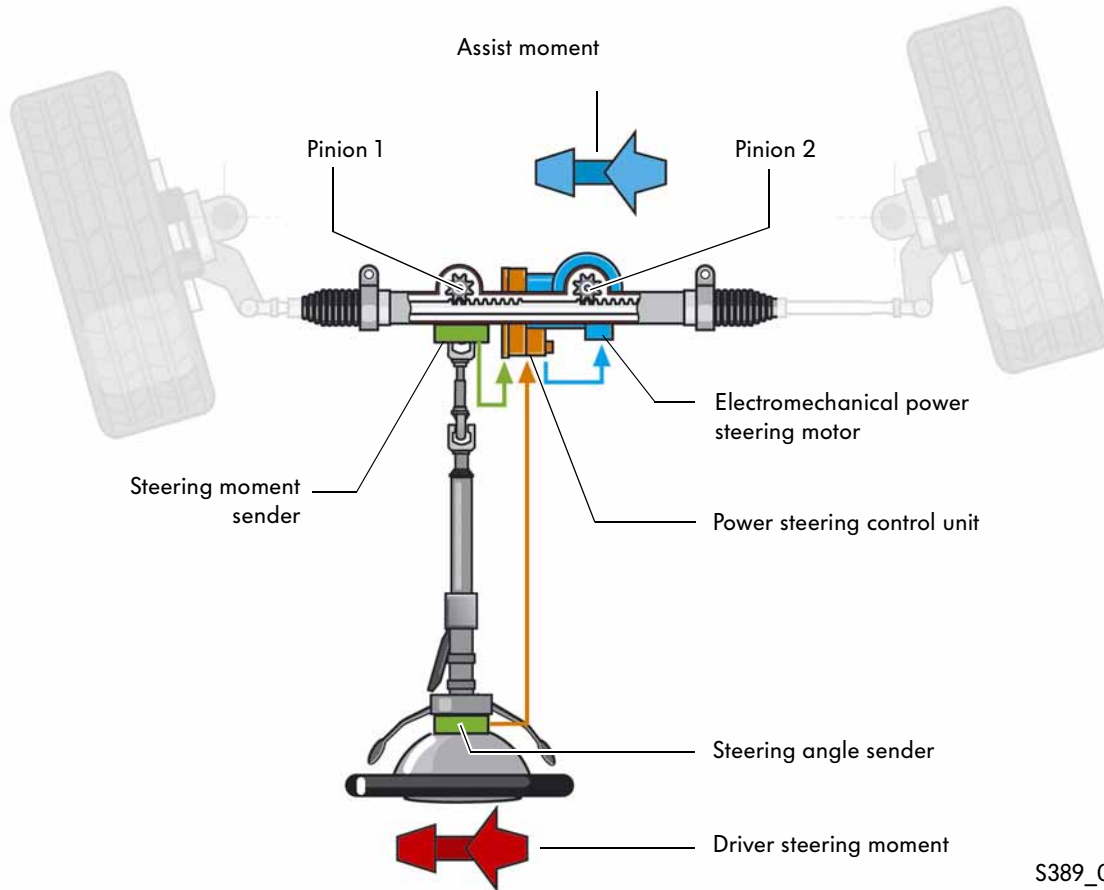

S389_004

The steering-assist function is applied when the driver turns the steering wheel. The torque that he applies twists a torsion bar in the electromechanical power steering. This is measured by the steering moment sender and is sent as a signal to the power steering control unit.

At the same time, the control unit uses the information from the steering angle sender to calculate how fast the driver turned the steering wheel and its current position.

The power steering control unit determines the required force for the steering assist from all the received data.

Using characteristic curves stored in the control unit, it operates the electric motor that transfers the necessary steering-assist moment to the steering linkage via the steering rack.

Function of ParkAssist

Parking procedure

The procedure for reversing into a parking space with ParkAssist can be broken down into four sections:

1. Activating ParkAssist
2. Finding a suitable parking space
3. Parking with the help of the parking steering function
4. Completing the parking procedure

1. Activating ParkAssist

ParkAssist has park distance control and parking steering functions. Both can be activated and deactivated with separate switches. The warning lamp in the button is illuminated and there is an indication in the multifunction display in the dash panel insert when the system is active.

When you reverse into a parking space, you do not need to decide first whether you want to carry out the parking procedure yourself, use the park distance control system or leave the steering procedure to the ParkAssist. Where you simply need to operate the accelerator, clutch and brake pedals.

You need to decide whether you want to reverse into a parking space on the right-hand side of the road or, into a space on the left on a one-way street. It is, of course, also possible just to use the ParkAssist to measure up a parking space. You then need to deactivate the system after the measurement is complete.

In this part of the description, we presume that the driver wants to reverse into a parking space on the right with ParkAssist and therefore presses the ParkAssist button.

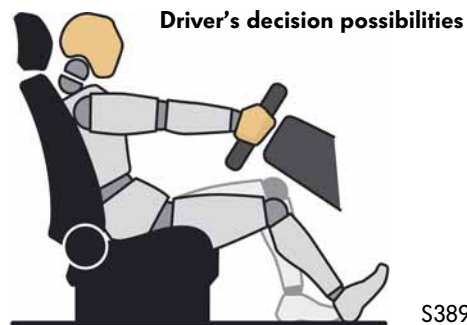

S389_027



Manual parking without assist systems



Manual parking with parking distance control



ParkAssist function, reverse right



ParkAssist function, reverse left



Manual parking, parking steering function only for establishing the size of the parking space

S389_028, 029, 030, 047, 031,

2. Finding a suitable parking space

The procedure for measuring a suitably sized parking space is carried out on both sides of the vehicle with an ultrasound sensor. In our example, the measurement is carried out by the front right sender for parking assistant steering on the right-hand side of the vehicle. In order to measure a parking space, the vehicle speed needs to be less than 30km/h. The ParkAssist sensors are switched off between 30km/h and 45km/h.

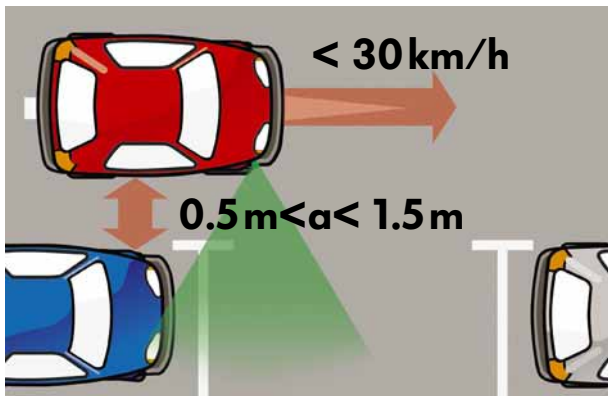

S389_025

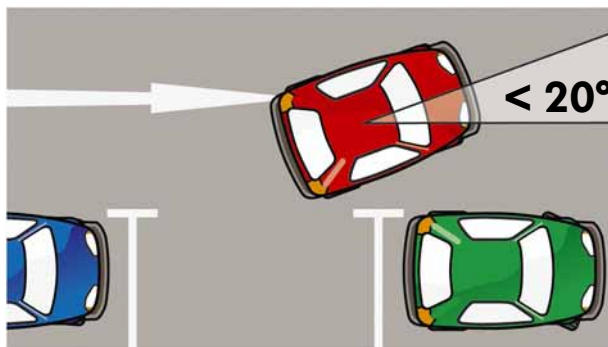

S389_032

The system then switches to stand-by mode as it presumes the search procedure has just been interrupted and will be continued at another point. At speeds above 45km/h, the ParkAssist is switched off completely and needs to be activated again.

If the speed is below 30km/h while you are searching for a parking space and the distance from the kerb at which the car passes is greater than 0.5m and less than 1.5m, the ParkAssist will measure out the right-hand side of the road for a suitable parking space. The result of the process is shown to the driver in the dash panel display using graphics to depict the vehicle and roadside.

If the system establishes that the vehicle reaches a passing angle of more than 20° from the kerb or the line of parked cars, the ParkAssist presumes that the driver, for example, wants to turn into another street, for example, and stops the search procedure.

To determine the passing angle, several lines can be monitored by the ParkAssist and compared with the vehicle longitudinal axis:

1. a line that is formed by other parked cars
2. the kerb
3. walls

Only the line that is closest to the vehicle is used. This prevents misinterpretations, if, for example, the kerb and walls are not parallel.



Function of ParkAssist

If the system does not find a sufficiently large parking space, the roadside appears as a line of shaded rectangles. If a parking space is large enough, it is displayed as a free space between the shaded rectangles. At the same time, the system checks whether the vehicle is in the right position to enter the parking space. This means the vehicle has been driven far enough forward to reverse into the parking space and the vehicle longitudinal axis is parallel to the parking space or the roadside.



Display shows:
Sufficiently sized parking space found.



Display shows:
Sufficiently sized parking space found, adjust position of vehicle.

Once the correct position has been reached, an arrow will point into the parking space to indicate that the ParkAssist is ready to carry out the parking steering function.

This however will only happen once the vehicle is stationary.

The letter R in the vehicle icon shows that the driver should select reverse gear himself.



Display shows:
Vehicle position OK.
Parking steering function can be carried out.

S389_021
S389_022
S389_023

The minimum size of a parking space is determined by the vehicle length and a required manoeuvring space plus a safety distance. The total length is measured so that the vehicle can be parked in a single parking procedure.

This means that the vehicle can be positioned by ParkAssist so that the driver will only have to drive forward manually to achieve an optimum position in the parking spot.

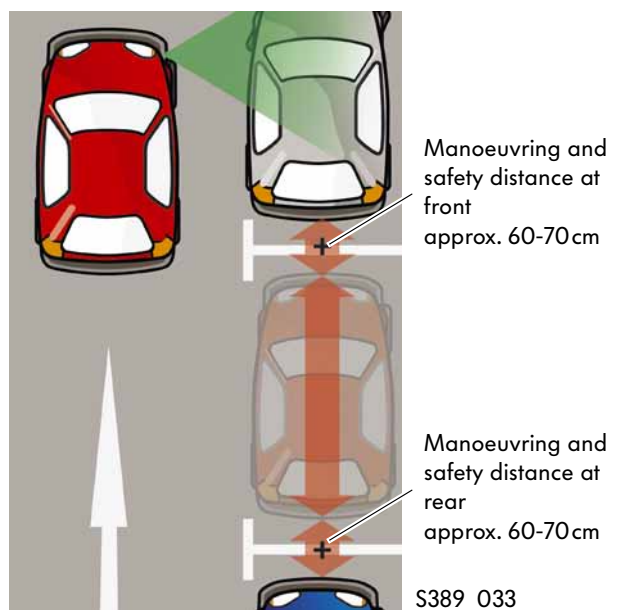

S389_033

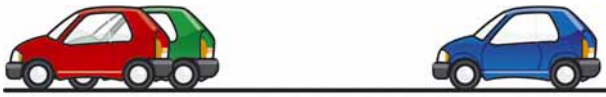

v = 0km/h

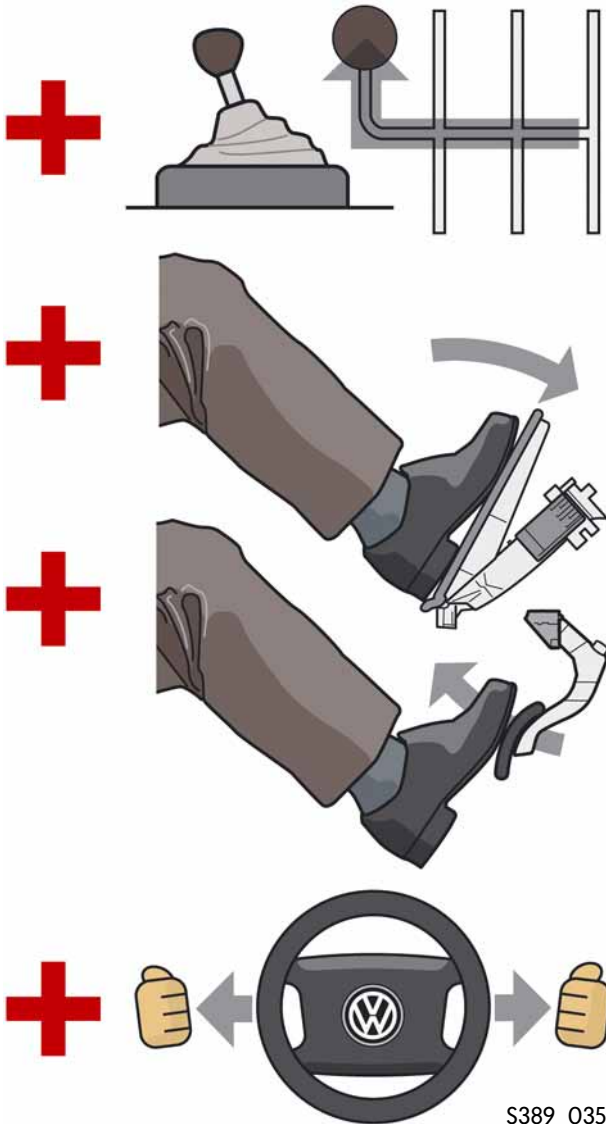

S389_035

3. Parking with the help of the parking steering function

The driver starts the automatic parking procedure by selecting reverse gear while the vehicle is stationary, pressing the accelerator pedal and releasing the brake pedal. He may not apply any steering moment to the steering wheel.

The dash panel display will now tell the driver that it is about to take over the steering and the driver should watch the surrounds of the vehicle so he can abort the parking procedure if in doubt or in case of danger.

The message displayed is as follows:
 "Steering interv. active! Monitor area around veh.!"

The manoeuvring procedure for reversing into a parking space is broken down into five movement segments in the control unit for parallel parking assist. This is necessary as the system does not have a direct optical control facility to react to unexpected developments during the manoeuvre. In simple terms, it has a standard parking manoeuvre stored in its "memory" and plays it back in the five steps when it is required.

ParkAssist thus follows a preset target path using the individual steps.

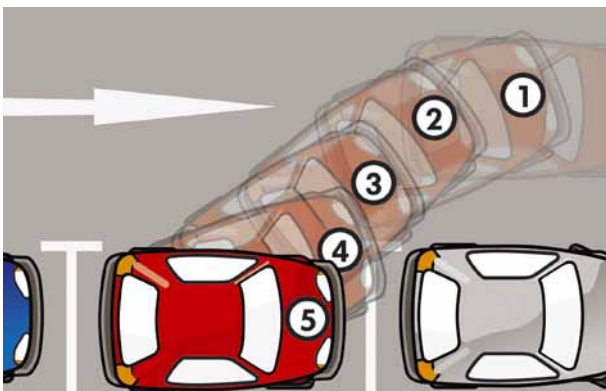

S389_036



Function of ParkAssist

Firstly, the wheels are straightened and the vehicle reverses a short distance when the driver presses the accelerator and releases the brake.

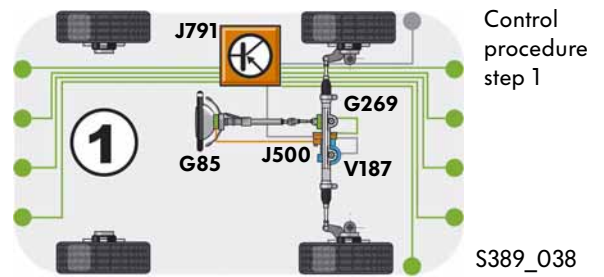

The control unit for parallel parking assist then signals for the wheels to be turned to the right with the electric motor.

The vehicle then reverses at an angle into the parking space. The driver needs to keep the speed under 7km/h.

If he exceeds this speed value, the system will abort the procedure.

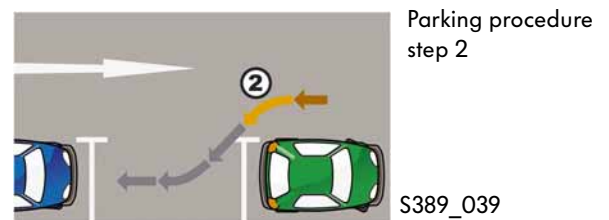
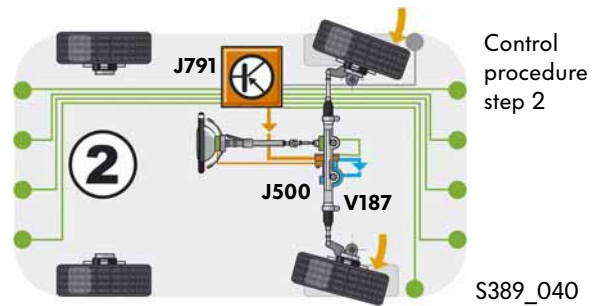

Using the distance data from the ultrasound sensors and the data from the steering angle sensor, the ParkAssist checks the position of the vehicle compared with the parking space and, using the manoeuvring steps stored in the control unit for parallel parking assist, determines when the wheels need to be returned to straight ahead to advance further into the parking space.

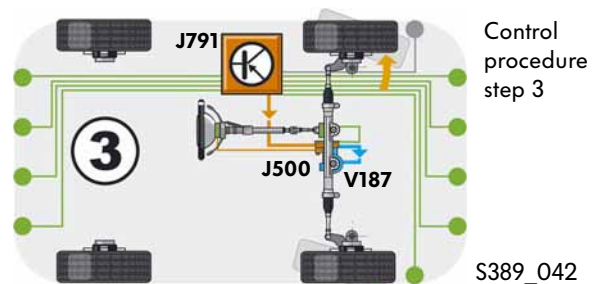

Control procedure step 4

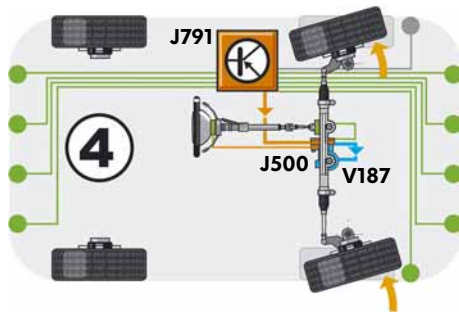

S389_044

Parking procedure step 4

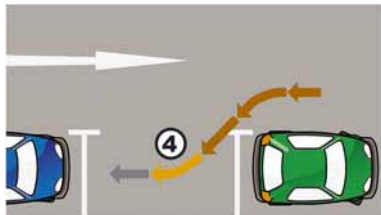

S389_043

Control procedure step 5

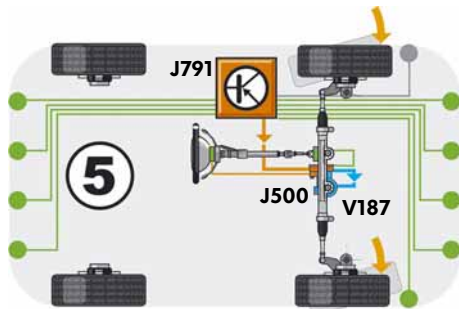

S389_046

Parking procedure step 5

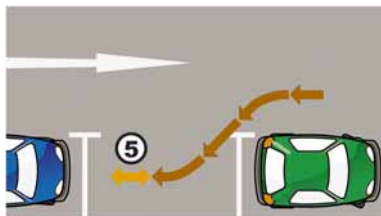

S389_045

Once this third movement segment is complete, the steering wheel now needs to be turned to the left in the fourth movement step so that the vehicle swings into the parking space. The vehicle now swings into the parking space and lines itself up parallel to the road again.

If the minimum distance from an object behind the vehicle is too close, there is an acoustic signal as you normally hear with the park distance control.



4. Completing the parking procedure

If the vehicle is not quite parallel to the kerbstone or house wall, this will also be recognised by the ParkAssist.

The driver now needs to deselect reverse gear while the vehicle is stationary, wait until the wheels have been moved to the straight ahead position and select first gear.

Now he can move the vehicle forwards a short distance until the display indicates that the parking procedure has been completed.

Once the parking procedure has been completed from the viewpoint of the ParkAssist, the display will change from "Steering interv. active! Monitor area around veh.!" to "Park Assist finished!". This deactivates the parking steering function and the warning lamp in the ParkAssist button will extinguish.

Designation

G85	Steering angle sender
G269	Steering moment sender
J791	Control unit for parallel parking assist
J500	Power steering control unit
V187	Electromechanical power steering motor

Function of ParkAssist

Special feature when reversing into parking spaces on the left

On one-way streets or in certain car parks, it is often possible to also park on the left-hand side of the road. Therefore the ParkAssist system also has an ultrasound sensor on the left-hand side of the vehicle to measure parking spaces and carry out the parking steering function to reverse into parking spaces on the left.

So that the system recognises the side of the street on which the driver wants to park, they will need to inform the ParkAssist about this since it cannot check and display both sides of the road at the same time.

The ParkAssist always presumes that you are looking for a parking space on the right-hand side. In this case, it will not require a signal from the driver.

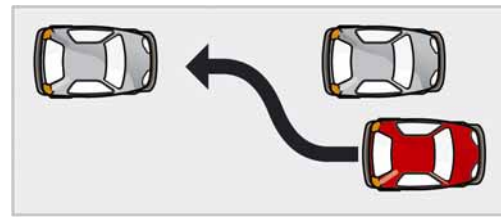

S389_048

If you want to search for a parking space on the left-hand side, the driver simply needs to activate the turn signal on the left to switchover the system.

The control unit now uses a second, stored set of manoeuvring steps to carry out the parking steering function.



The described procedure only applies to countries driving on the right; you will find further information on this in the chapter Service.

System limits

The measurement of the parking space and the subsequent parking procedure can be influenced by the surrounding conditions.

For example, ParkAssist may have problems recognising a kerbstone if leaves, rubbish or snow hide its shape. In addition, leaves and snow disperse the reflected ultrasound signals. As a result, the ParkAssist only picks up a weakened ultrasound echo that can lead to misinterpretations.

Other examples of the limits of the system are road openings or driveways. What the ParkAssist believes to be an ideal parking space may turn out upon a closer look to be a driveway with closed gate.







These limitations underline the fact that the ParkAssist system cannot replace the awareness of the driver. The driver is responsible.





Overview of activation conditions

The following criteria needs to be met before the ParkAssist steering function can be used:

Activate ParkAssist

	Parking assistant steering button should be pressed
	ESP activated
	No trailer attached
	Speed below 45km/h

Carrying out parking space measurement on right and left

	Turn signal set to left (only applies in countries with right-hand traffic)
	Speed below 30km/h
	Side spacing between 0.5m and 1.5m
	Angle between vehicle longitudinal axis and roadside max 20° (passing angle)

Reversing into parking spaces on right and left

	Speed = 0km/h and reverse gear selected and steering moment on steering wheel below 5Nm
	Driver activities (accelerator, clutch, brake) within system time limitations (180s)

S389_061 - S389_070



Function of ParkAssist

Abort criteria and system messages

Due to the complexity of the movement procedure and the possible interference, a wide range of abort conditions have been defined to achieve maximum protection against damage.

The following conditions prevent the ParkAssist from functioning:



Action	Reaction and message	Gong	K241
Deactivation of ESP ESP intervention	"Park Assist finished! ESP switched off" "Park Assist: ESP intervention"		
Trailer attached to vehicle	"Park Assist finished! Trailer"		
Travelling at less than 10km/h after ignition switched on	"Park Assist finished!"		
Travelling at more than 45km/h	"Park Assist: Speed too high!"		









The following conditions lead to the measuring procedure being aborted:

Action	Reaction and message	Gong	K241
Car travelling above 30km/h	"Park Assist: Speed too high!"		





The following conditions lead to the parking procedure being aborted:

Action	Reaction and message	Gong	K241
Car travelling above 7km/h	"Park Assist: Speed too high!"		
Exceeding a time limit of 180 seconds between selecting reverse gear and ending the parking procedure.	"Park Assist finished! Time limit exceeded"		

The following conditions lead to the parking procedure being aborted (continued):

Action	Reaction and message	Gong	K241
The driver exceeding a steering moment of 5Nm.	“Driver steering intervention! Please take over steering!”		
Deselecting reverse gear	“Park Assist finished! Please take over steering!”		
Deactivating ESP	“ESP switched off! Please take over steering!”		
Deactivating ParkAssist	“Steering interv. finished! Please take over steering!”		

Further system messages on faults when ParkAssist active:

Fault	Reaction and message	Gong	K241
ParkAssist faulty	“Park Assist defective! Workshop!”		 flashing
Message failure or system fault	“Park Assist finished! System fault”		



Electrical components

Sensors

Front left sender for parking assistant steering on left side of vehicle G568 Front right sender for parking assistant steering on right side of vehicle G569

The two sensors are ultrasound sensors and both are mounted on the left-hand and right-hand side of the front end. They are inserted into a mounting from the rear that is clipped into the plastic cover of the front end. The senders for parking assistant steering cannot be confused with the parking aid senders as they are a different size. They are larger as they have a larger scanning angle and range.

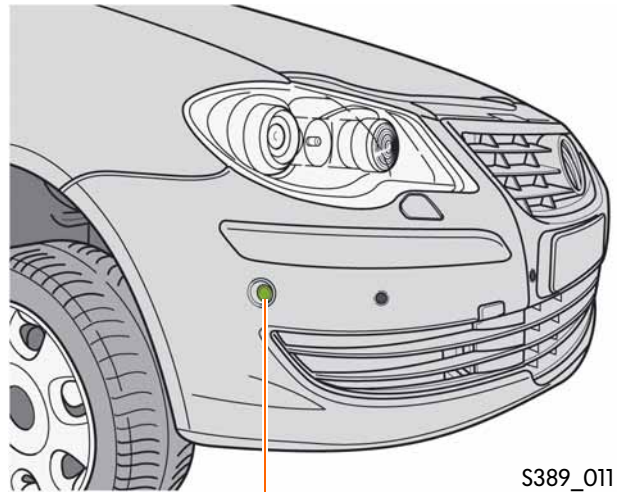

Signal use

The signals from both sensors are exclusively used for the ParkAssist functions. They are used to measure possible parking spaces and to monitor the side spacing at the front end during the parking procedure.

The signal is used in the calculation of the passing angle.

Effect upon failure

The sensor is capable of self-diagnosis. If one of the sensors is faulty, the ParkAssist functions will not be available.

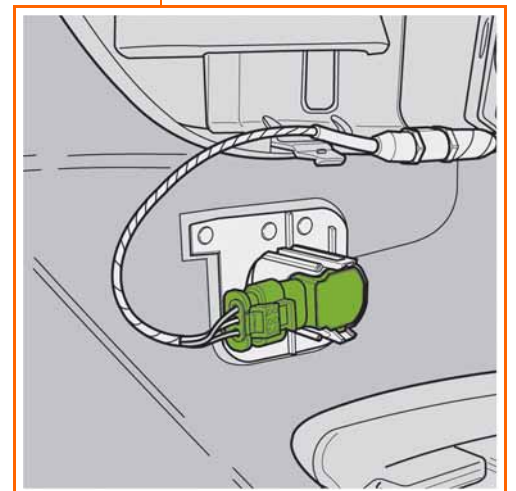

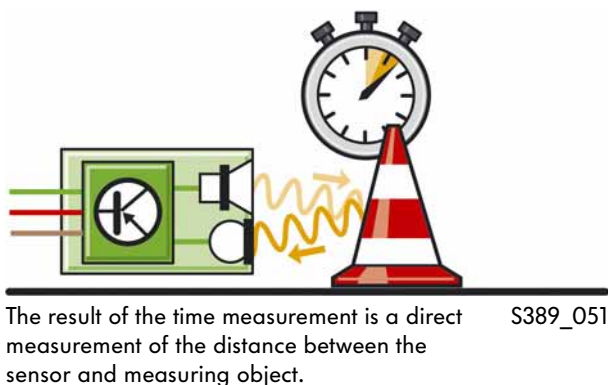
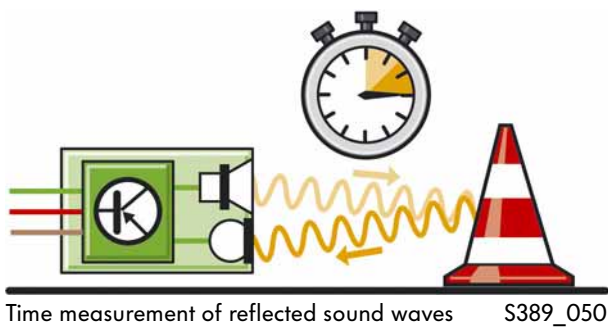
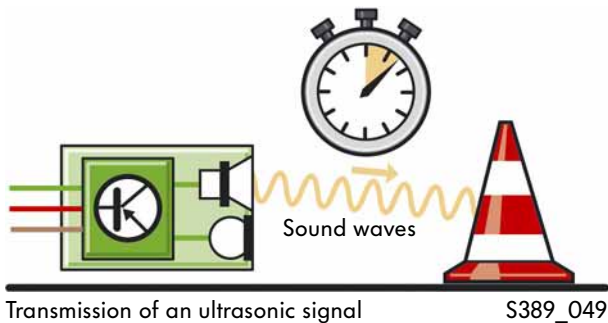
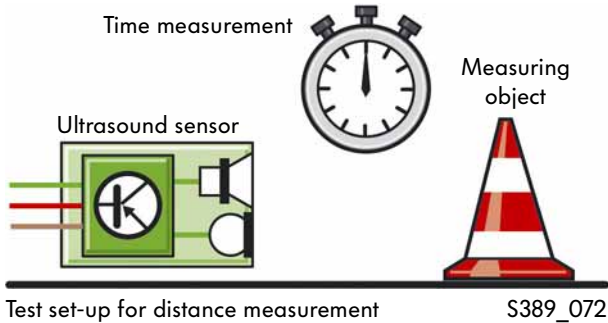

How it works

Ultrasound sensors are small transmitters and receive units.

The principle is based on the ultrasound sensor transmitting an inaudible sound in the ultrasonic range. This sound travels through the surrounding medium (e.g. air) at a constant speed in the form of sound waves.

Sound waves are concentric, wave-shaped changes in the density and pressure of the surrounding air particles that propagate around the sound source. The speed at which sound travels depends on the density of the medium through which it is passing. In air, sound travels at 343m/s at a normal pressure (1bar) and a temperature of 20°C. In water at, for example, 0°C, it travels at 1407m/s.

The relation between the temperature and the speed at which sound travels is the reason why the signal from the ambient temperature sender is used as a correction variable in the system control.

If sound waves hit an object, for example, a wall, they will be reflected to varying degrees depending on the properties of the wall. This means sound waves return to the sensor and are picked up using a microphone. The sensor measures the time between transmission and reception of the reflected ultrasonic waves. The control unit for parallel parking assist can determine the distance from an object with this time measurement.



Electrical components

Ultrasound sensors for park distance control function (parking aid)

The four ultrasound sensors are mounted at the front and four at the rear as follows:

- Rear left parking aid sender G203
- Rear centre left parking aid sender G204
- Rear centre right parking aid sender G205
- Rear right parking aid sender G206
- Front right parking aid sender G252
- Front centre right parking aid sender G253
- Front centre left parking aid sender G254
- Front left parking aid sender G255

All sensors are inserted from the back of the plastic cover on the front and rear.

How it works

The eight sensors work in the same way as the two senders for parking assistant steering G568 and G569. They have a smaller scanning range and scanning angle, however.

The sensors are placed so that their scanning areas are overlapped slightly. There is therefore no “dead” area where obstacles cannot be detected.

Signal use

The sensor signals are used both for the park distance control and the ParkAssist. The two functions involve the distance of the vehicle from other objects in the vicinity of the vehicle being measured.

Effect upon failure

All eight sensors are capable of self-diagnosis. A faulty sensor leads to failure of the whole system.

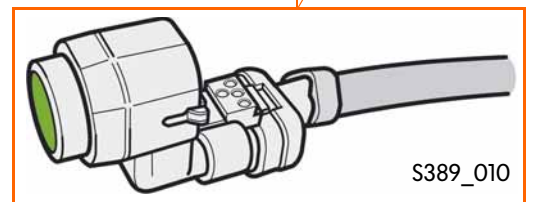
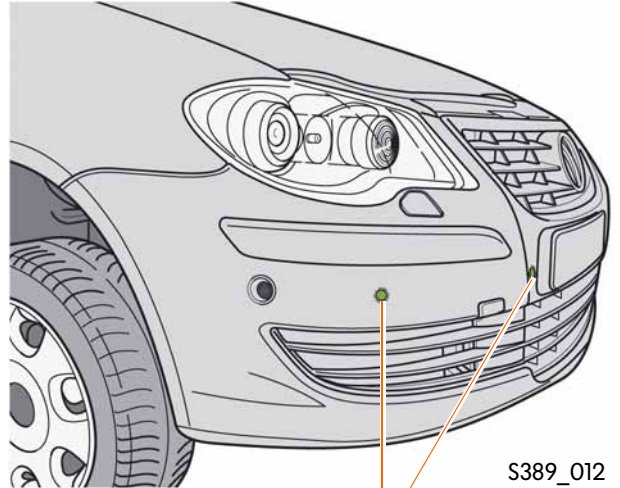

Parking aid button E266 with parking aid warning lamp K136



S389_007, 013

The button is in the line of buttons above the gear selector next to the parking assistant steering button. The warning lamp indicates that the function is active when illuminated yellow.

Signal use

The park distance control (parking aid) is switched on manually with the button.

Effect upon failure

If the park distance control fails due to technical faults in related components, this will be indicated by the warning lamp flashing.



Parking assistant steering button E581 with warning light for parking assistant steering K241

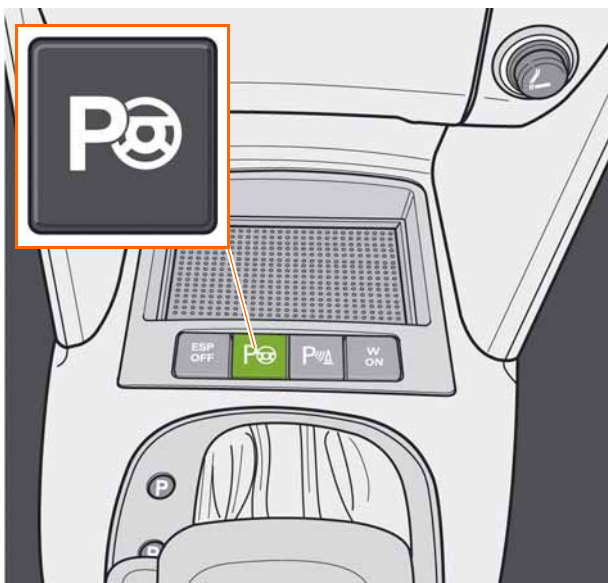

S389_008, 014

This button is also in the line of buttons above the gear selector. It is to the right of the button for deactivating the ESP function. The warning lamp indicates that the ParkAssist function is active when illuminated yellow.

Signal use

The parking steering function of the ParkAssist is switched on manually with the button.

Effect upon failure

If the ParkAssist fails due to technical faults in related components, this will be indicated by the warning lamp flashing.

Electrical components

Actuators

Rear parking aid warning buzzer H15 Front parking aid warning buzzer H22

The warning buzzer H15 is in the boot at the rear right. The warning buzzer H22 is to the left of the steering column near to the control unit for parallel parking assist.

The park distance control issues acoustic signals via the buzzer at intervals that inform the driver how far he is from an object when manoeuvring into a parking space. If the signal sequence becomes a continuous sound, this indicates that the smallest safe distance from the object has been reached or undershot.

Effect upon failure

Both buzzers are covered by the self-diagnosis system. If one or both buzzers fail, the park distance control (parking aid) will no longer be available for the respective area in front of or behind the vehicle and an entry will be made in the fault memory.

The gong that provides information on the status of the parking steering function is not signalled with the buzzer, but with the acoustic output in the dash panel insert.

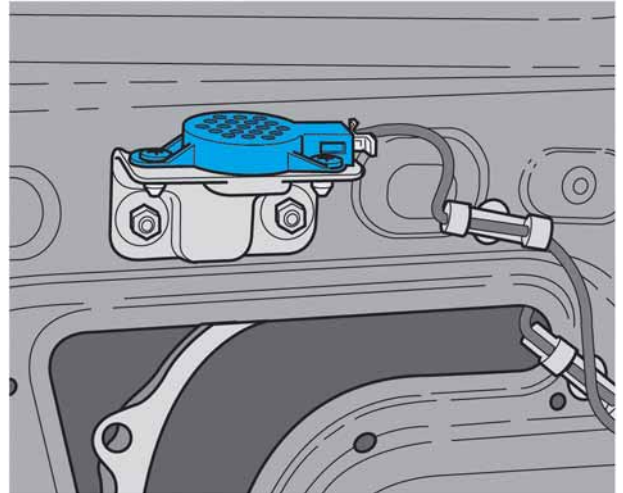

Rear parking aid warning buzzer

S389_071

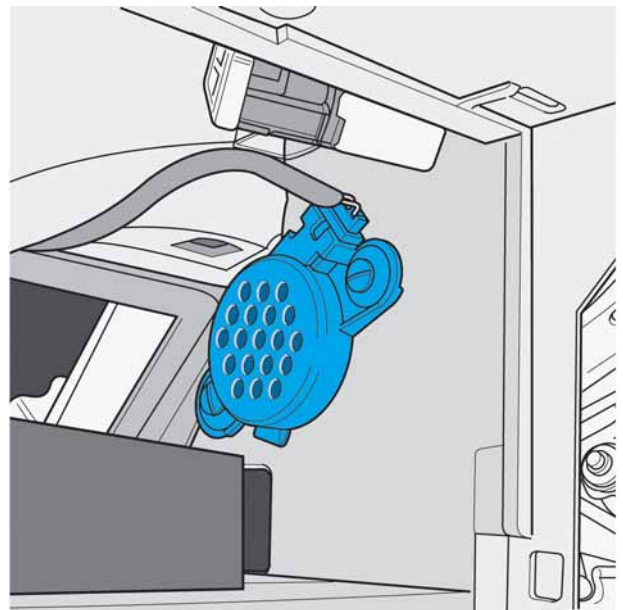

Front parking aid warning buzzer

S389_005

System control unit

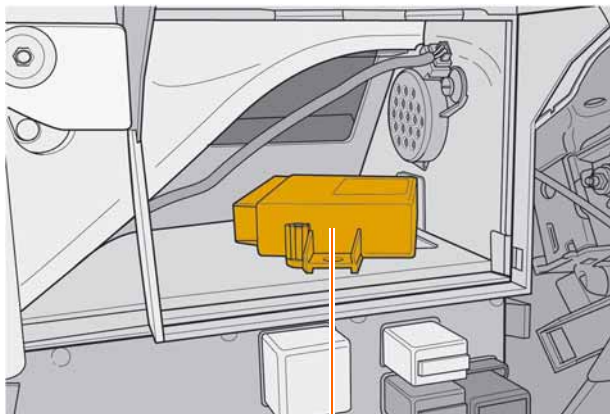

S389_006

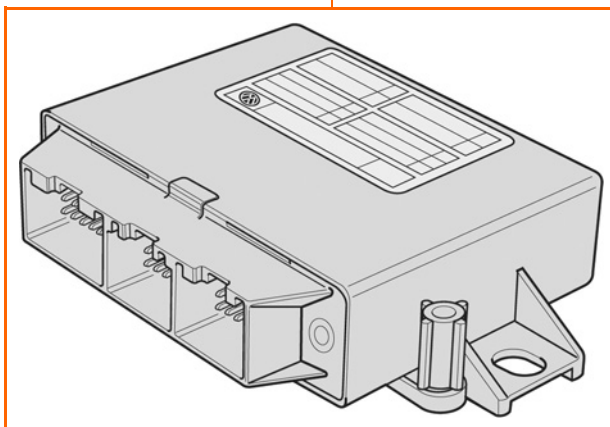

S389_018

Control unit for parallel parking assist J791

The control unit is located above the onboard supply control unit to the left of the steering column.

As mentioned, it incorporates both the parking steering function and the park distance control (parking aid).

The parking aid control unit is omitted if the vehicle is equipped with the parking steering assist.

If a vehicle is equipped with the park distance control it will only be fitted with the parking aid control unit, retrofitting the parking steering function is not normally possible.



Functional Diagram

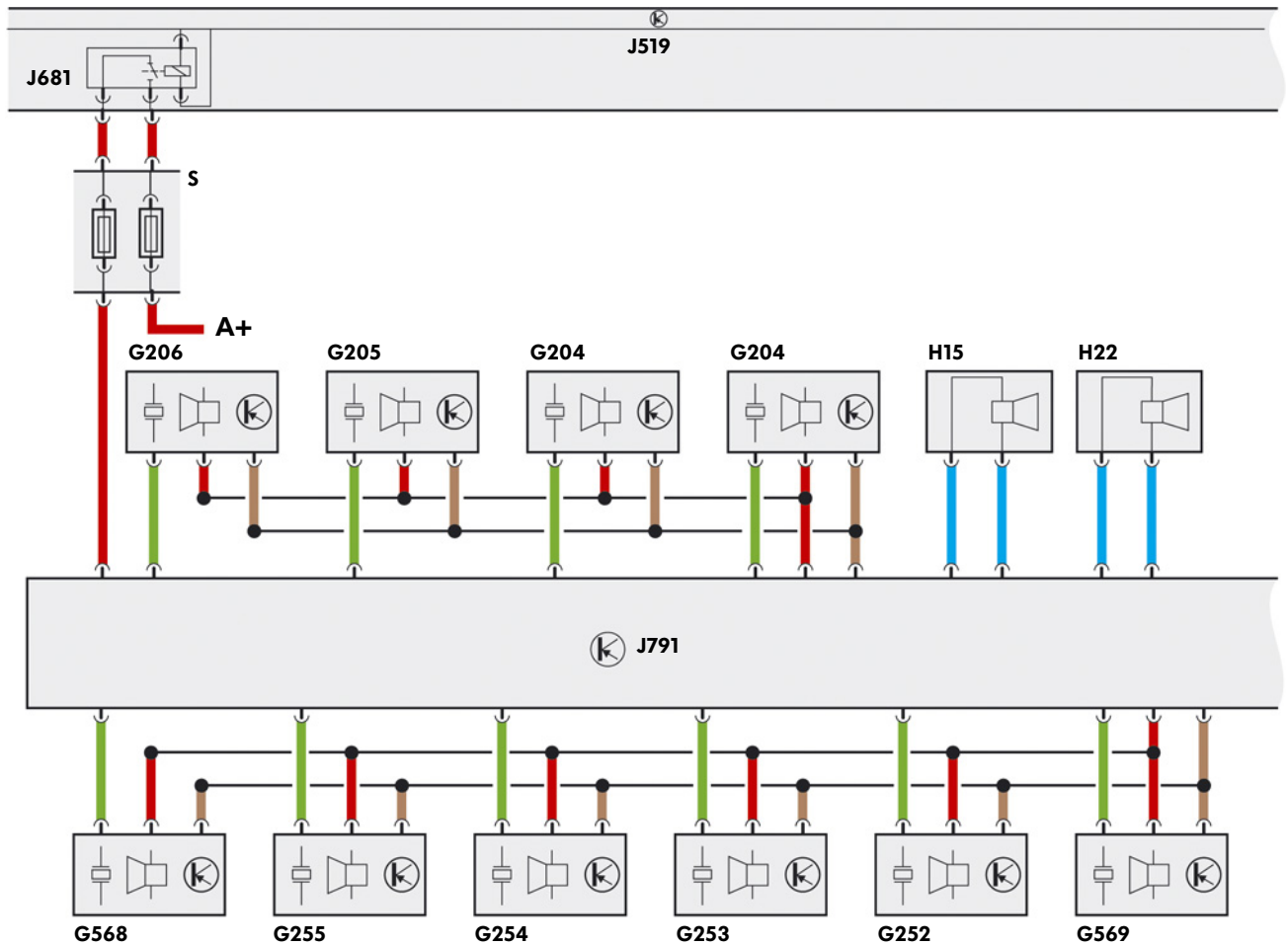

S389_053

G203	Rear left parking aid sender	H15	Rear parking aid warning buzzer
G204	Rear centre left parking aid sender	H22	Front parking aid warning buzzer
G205	Rear centre right parking aid sender	J519	Onboard supply control unit
G206	Rear right parking aid sender	J681	Terminal 15 voltage supply relay 2
G252	Front right parking aid sender	J791	Control unit for parallel parking assist
G253	Front centre right parking aid sender	A	Battery
G254	Front centre left parking aid sender	S	Fuse
G255	Front left parking aid sender		
G568	Front left sender for the parking assistant steering on left side of vehicle		
G569	Front right sender for the parking assistant steering on right side of vehicle		

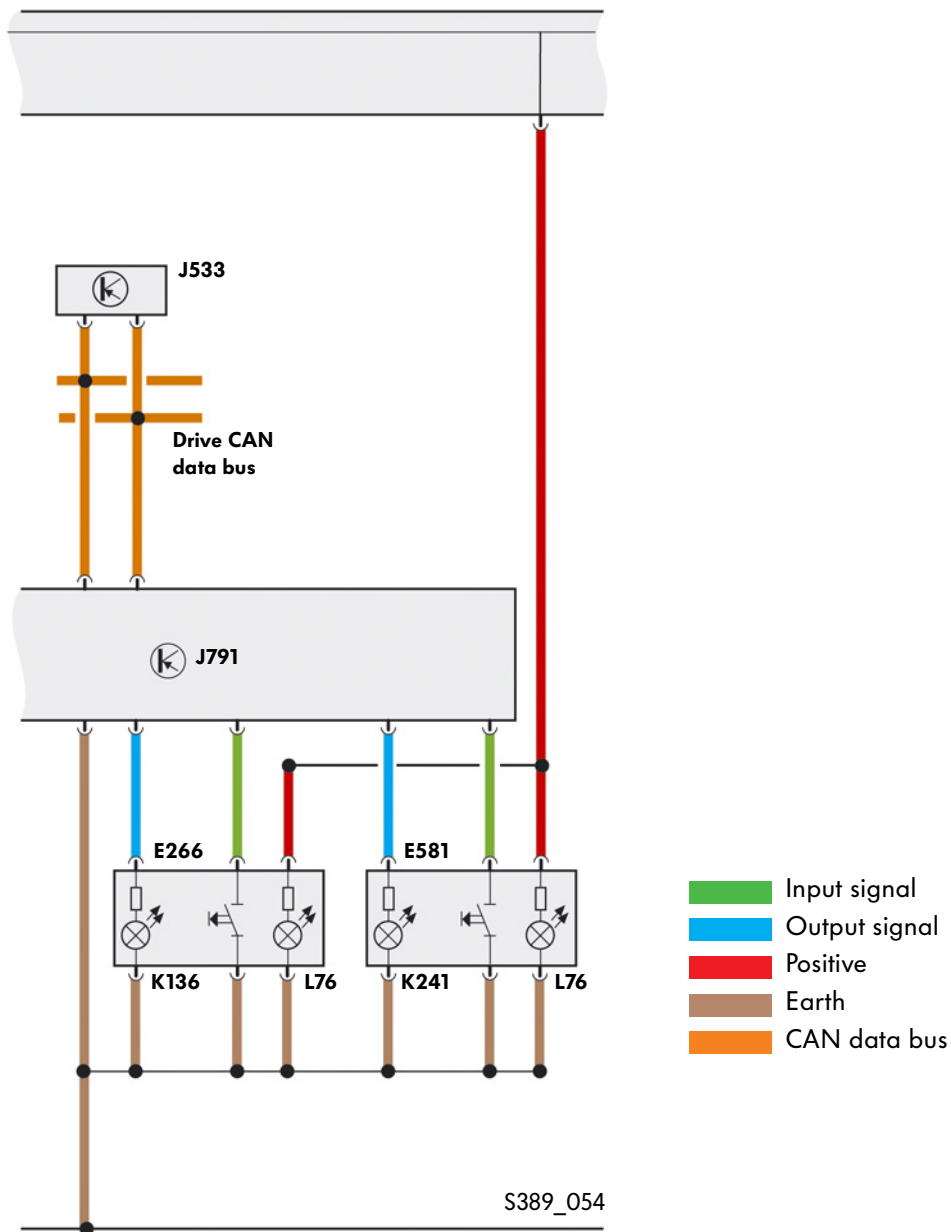

- Input signal
- Output signal
- Positive
- Earth
- CAN data bus

- S389_054
- E266 Parking aid button
 - E581 Parking assistant steering button
 - J533 Data bus diagnostic interface
 - J791 Control unit for parallel parking assist
 - K136 Parking aid warning lamp
 - K241 Warning light for parking assistant steering
 - L76 Button illumination bulb

Diagnosis

The VAS 5051 vehicle diagnosis, measuring and information system and the VAS 5052 vehicle diagnosis and service information system are available for the new ParkAssist system.

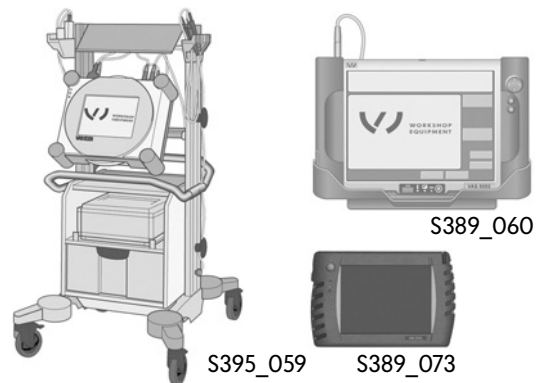

For more detailed information on the procedure and guided fault finding, please refer to chapter 7 of the VAS 5051 operating manual.

Country-specific information

The ParkAssist system needs to be configured differently for countries driving on the left than those driving on the right.

The setting is made using the left-hand drive/right-hand drive coding with the VAS 5051.

Among other things, the information for parking on the right-hand or left-hand side of the road stored in the control unit for parallel parking assist is swapped over.

This means, for example, that drivers in the United Kingdom need to set the turn signal to “Right” if they want to park on the right-hand side of the street. By default, the system presumes that you want to park on the left-hand side of the street if the coding is set to right-hand drive.

In Germany, drivers need to set the turn signal to “Left” because the system presumes they want to park on the right-hand side of the street by default due to the left-hand drive coding.



Please ensure that the vehicle is set to the correct coding from LHD to RHD after a stay in countries that drive on the other side of the road.

Which answers are correct?

One or several of the answers could be correct.

1. Which statement is correct?

- a) The parking steering function takes care of the complete parking manoeuvre fully automatically. The driver does not need to perform any tasks while parking.
- b) The parking steering function only checks the distances from objects in the area around the vehicle during the parking manoeuvre.
- c) The parking steering function takes over the steering when reversing into parking spaces on the left and right. The driver still has to operate the brakes, clutch and accelerator and still holds responsibility during the whole procedure.

2. Which of the following functions can be carried out with the ParkAssist system?

- a) Park distance control (parking aid)
- b) Measuring and displaying parking spaces on both sides of the road at the same time.
- c) The steering when driving forward into parking spaces on the right.
- d) The steering when driving forward into parking spaces on the left.
- e) The steering when reversing into parking spaces on the right.
- f) The steering when reversing into parking spaces on the left.

3. Above which speed does the ParkAssist system cancel the measurement of a parking space and switch to stand-by mode?

- a) From a speed of 45km/h
- b) From a speed of 30km/h
- c) From a speed of 15km/h





© VOLKSWAGEN AG, Wolfsburg
All rights and rights to make technical alterations reserved.
000.2811.84.20 Technical status 01.2007

Volkswagen AG
Service Training VSQ-1
Brieffach 1995
38436 Wolfsburg

♻️ This paper was manufactured from pulp that was bleached without the use of chlorine.