

Bosch Motorsport  
**Equipment for High Performance Vehicles**

Edition 2008/1



**BOSCH**





# Contents

## Engine Control Units

Motronic MS 3 Sport.....	7
Motronic MS 3.1.....	9
Motronic MS 4 Sport.....	11
Motronic MS 4.0.....	12
Motronic MS 4.2.....	13
Motronic MS 4.4 Sport.....	14
Motronic MS 4.4.....	15
Motronic MS 5.2.....	16
Motronic MS 15.1.....	18
Motronic MS 15.2.....	19

## Displays

Display DDU Sport.....	21
Display DDU 4.....	22
Display DDU 6.....	23

## Communication

### Data Logging and Signal Processing

Data Logger C Sport.....	25
CardMemory C40 / C40 Plus.....	26
Data Logging Accessories.....	27
Data Logging System DLS.....	28
CardMemory C 55.....	29
Modular Sensor Interface MSI 55.....	30
Burst Telemetry Transmitter BT 55.....	31
Lambdatronic LT4.....	32
AWS LSU 4.9.....	35
CAN Module EM-A6.....	36
CAN Module EM-C.....	37
CAN Module EM-D1.....	38
CAN Module EM-D8.....	39
CAN Module EM-H4.....	40
CAN Module EM-I4.....	41
CAN Module EM-L5.....	42
CAN Module EM-P5.....	43
CAN Module EM-25, EM-50, EM-100.....	44
ThermoCAN Module.....	45

### Telemetry

Telemetry Unit FM40.....	46
Telemetry Accessories.....	47

### Analysing

WinDarab.....	49
---------------	----

### Application

INCA-MSD.....	51
Modas.....	53
KIC 2.....	54
K-Line Extension Set.....	55
MSA-Box.....	56

## Handheld Test Devices

Lambda Tester.....	57
RS 2000.....	58

## Simulation

LapSim.....	59
-------------	----

## Laptrigger Systems

Laptrigger IR-02.....	61
Laptrigger HF 24.....	62

## Diesel System Components

Diesel System Components.....	65
-------------------------------	----

## Sensors

### Pressure Sensors Air

Absolute Pressure Sensor PSA-B.....	67
Absolute Pressure Sensor PSA-C.....	68
Absolute Pressure Sensor PSB-2.....	69
Absolute Pressure Sensor PSB-4.....	70
Absolute Pressure Sensor PSP.....	71
Absolute Pressure Sensor PST.....	72

### Pressure Sensors Fluid

Absolute Pressure Sensor PSC-10.....	75
Absolute Pressure Sensor PSC-250.....	77
Absolute Pressure Sensor PSM.....	78
Absolute Pressure Sensor PSS.....	79

### Pressure Sensors Differential

Differential Pressure Sensor DP-A.....	80
Differential Pressure Sensor DP-B.....	81
Differential Pressure Sensor DP-C.....	82
Pitot Static Tube PT.....	84

### Temperature Sensors

Temperature Sensor TI-16.....	86
Temperature Sensor TI-100.....	88
Temperature Sensor NTC M6.....	90
Temperature Sensor NTC M6-H.....	92
Temperature Sensor NTC M8.....	94
Temperature Sensor NTC M8-F.....	96
Temperature Sensor NTC M12.....	98
Temperature Sensor NTC M12-H.....	100
Temperature Sensor NTC M12-L.....	102
Temperature Sensor PT100 M14.....	104

### Thermocouple Probes

Thermocouple Probe TCP-K.....	106
Thermocouple Probe TCP-N / TCP-NF..	108

### Speed Sensors Inductive

Inductive Speed Sensor IA.....	110
Inductive Speed Sensor IA-C.....	111
Inductive Speed Sensor IS.....	112
Inductive Speed Sensor IS-C.....	113

Inductive Speed Sensor IS-T .....	114
<b>Speed Sensors Hall-effect</b>	
Speed Sensor HA-M.....	115
Speed Sensor HA-P .....	116
<b>Lambda Sensors</b>	
Lambda Sensor LSM 11 .....	117
Lambda Sensor LSM 11-PM .....	119
Lambda Sensor LSM 11-RM .....	120
Lambda Sensor LSU 4.2 .....	121
Lambda Sensor LSU 4.9 .....	123
Lambda Sensor Mini-LSU 4.9 .....	125
<b>Knock Sensors</b>	
Knock Sensor KS-P .....	127
Knock Sensor KS-R .....	128
<b>Rotary Potentiometers</b>	
Rotary Potentiometer RP 55.....	130
Rotary Potentiometer RP 86.....	131
Rotary Potentiometer RP 100.....	132
Rotary Potentiometer RP 100 twin.....	134
Rotary Potentiometer RP 130.....	135
Rotary Potentiometer RP 130-M.....	136
Rotary Potentiometer RP 308.....	137
Rotary Potentiometer RP 350-M.....	139
<b>Linear Potentiometers</b>	
Linear Potentiometer LP 10 .....	140
Linear Potentiometer LP 25 twin .....	141
Linear Potentiometer LP 50 .....	142
Linear Potentiometer LP 50 twin .....	143
Linear Potentiometer LP 75 .....	144
Linear Potentiometer LP 75F .....	145
Linear Potentiometer LP 100 .....	146
Linear Potentiometer LP 100F .....	147
Linear Potentiometer LP 150 .....	148
<b>Wire Potentiometers</b>	
Wire Potentiometer WP 35.....	149
Wire Potentiometer WP 50.....	150
Wire Potentiometer WP 75.....	151
Wire Potentiometer WP 100.....	152
Wire Potentiometer WP 120.....	153
Wire Potentiometer WP 125.....	154
<b>Acceleration Sensor</b>	
Accelerometer AM 600 .....	155
<b>Gear Shift Sensors</b>	
Gear Shift Sensor GSS .....	156
Gear Shift Sensor GSS-2 .....	158
<b>Ride Height System</b>	
Ride Height System RHS .....	160
<b>Yaw Rate Sensor</b>	
Yaw Rate Sensor YRS 2 .....	161

## Vehicle Components

### Chassis Control

ABS M4 .....	163
--------------	-----

### Injection Valves

Injection Valve EV 6 .....	164
Injection Valve EV 12 .....	166
Injection Valve EV 14 .....	167

### HP Injection Valves

HP Injection Valve HDEV 1.2.....	168
HP Injection Valve Mini-HDEV 1.2.....	169
HP Injection Valve Mini-HDEV LV.....	170
HP Injection Valve Mini-HDEV LV 8A.....	171

### Power Stage Units

HPI 1.16 LV / LVD .....	173
HPI 1.16 HV / HVD .....	174

### Ignition Coils

Single Fire Coil M .....	175
Single Fire Coil P .....	176
Single Fire Coil PT .....	177
Single Fire Coil S .....	180
Single Fire Coil S16 .....	181
Double Fire Coil 2x2.....	184
Double Fire Coil 3x2.....	187

### Spark Plugs

Spark Plugs.....	188
------------------	-----

### Fuel Pumps

Fuel Pump FP 100 .....	189
Fuel Pump FP 165 .....	190
Fuel Pump FP 200 .....	191
HPI Fuel Pump HDP 1.....	192
Diesel Fuel Pump DFP 300 .....	193

### Fuel Pressure Regulators

Fuel Pressure Regulator 05-40 A .....	194
Fuel Pressure Regulator 14-50 .....	195
Fuel Pressure Regulator 15-50 .....	196
Fuel Pressure Regulator 19-50 .....	197
Fuel Pressure Regulator 20x120.....	198
Fuel Pressure Regulators Mini/Mini M..	199
Fuel Pressure Regulator Mini A .....	200
Fuel Pressure Regulator Mini 38 .....	201
Fuel Pressure Regulator Mini 50 .....	202
HPI Control Valve DSV.....	203

### Starters

Starter 1,4 kW .....	204
Starter 1,7 kW .....	205
Starter 2,0 kW .....	206

### Alternators

Alternator 90 A .....	207
Alternator GCM1 .....	209
Alternator F1-01 .....	212
Alternator F1-02 .....	213

Alternator F1-03..... 214

**Relay**

Relay 25 A..... 215

**Switches**

Switches..... 216

**Appendix**

Vibration Profile 1..... 218

Vibration Profile 2..... 219

Vibration Profile 3..... 220

# Engine Control Units

## Motronic MS 3 Sport

The MS 3 Sport is the first Bosch engine management system in full hybrid technique and for engines up to 6 cylinders. Two independent circuits are available for vibration knock detection and knock control. Injection time, injection end timing and ignition timing are calculated from basic maps and can be corrected by different engine parameters. Also two closed loop wide range lambda circuits are available. An external data logger or a DDU can be connected via CAN interface. The MS 3 Sport is developed with EasyHandling software.

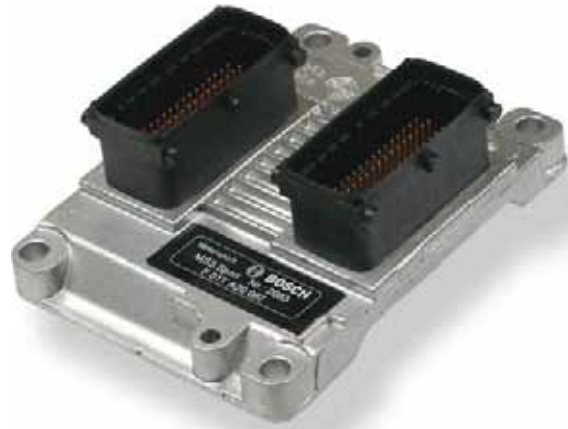

### Mechanical data

Extremely small and flat aluminium pressure casting housing	
Connectors with high pin density	
Extremely shock and vibration proof hybrid technology	
Four housing fixation points	
Size	120 x 90 x 40 mm
Weight	250 g

### Functionality

Asymmetric injection timing possible
Asymmetric ignition timing possible
Dual lambda control
Knock control (optional)
Traction control (optional)
Electronic throttle control (optional)
Support of 60-2 and 36-2 ignition trigger wheels

### Electrical data

#### Inputs

2 inputs for exhaust gas temperature sensors
2 lambda interfaces LSU
4 inputs for Hall-effect wheel speed sensors
1 input for inductive or Hall-effect crankshaft sensor
15 universal inputs 0 ... 5 V
2 inputs for vibration knock sensors
6 digital inputs

#### Outputs

6 injection power stages
6 ignition power stages
16 power stages (2 A/1 A; low side; PWM)
2 power stages for lambda heater
1 H-bridge (5 A)
2 sensor supply 5 V/100 mA

#### Communication interfaces

1 K-line serial interface
1 CAN interface for external communication

**Necessary equipment**

KIC2-standard connector	<b>B 261 206 859</b>
KIC2-diagnosis connector with ignition bridge	<b>B 261 206 866</b>
KIC2-diagnosis connector without ignition bridge	<b>B 261 206 867</b>

**Conditions for use**

ECU temperature	-40 ... 125 °C
Max. power consumption	10 W at 14 V
Max. vibration	<i>Vibration Profile 3 (see Appendix)</i>

**Cable harness connectors**

	<b>D 261 205 139</b>
	<b>D 261 205 140</b>

**Part number**

MS 3 Sport	<b>F 01T A20 067</b>
------------	----------------------



## Motronic MS 3.1

The MS 3.1 is the first Bosch engine management system in full hybrid technique and for engines up to 6 cylinders. Two independent circuits are available for vibration knock detection and knock control. Injection time, injection end timing and ignition timing are calculated from basic maps and can be corrected by different engine parameters. Also two closed loop wide range lambda circuits are available. An external data logger or a DDU can be connected via CAN interface.



Mechanical data	
Extremely small and flat aluminium pressure casting housing	
Connectors with high pin density	
Extremely shock and vibration proof hybrid technology	
Four housing fixation points	
Size	120 x 90 x 40 mm
Weight	250 g

Functionality	
Engine management system for 4- and 6-cylinder engines	
Sequential fuel injection	
Ignition timing	
Lambda control	
Knock control	
Fuel cut off	
Component diagnosis	

Conditions for use	
ECU temperature	-40 ... 125 °C
Max. power consumption	10 W at 14 V
Max. vibration	<i>Vibration Profile 3 (see Appendix)</i>

Electrical data	
<b>In general</b>	
2 microcontrollers with 16 bit organisation calculation capacity 20 MIPS	
<b>Inputs</b>	
2 lambda LSU 4 interfaces	
3 analog inputs 0 ... 5 V for water temperature, oil temperature, intake air temperature	
3 analog inputs 0 ... 5 V for oil pressure, fuel pressure, ambient pressure	
1 analog input 0 ... 5 V for throttle position sensor	
1 digital input for laptrigger	
1 digital input for wheel speed sensor	
1 input for inductive crankshaft sensor	
1 input for Hall-effect camshaft sensor	
2 knock sensor interfaces	
<b>Outputs</b>	
6 injection power stages with diagnosis interface	
2 high current power stages (8 A) with diagnosis interface for LSU heating	
6 ignition power stages	
Sensors supply output	5 V/100 mA
Separate supply output for throttle position sensor	5 V/100 mA
2 power stages (1 A) for main relay and fuel pump relay control	
<b>Communication interfaces</b>	
1 K-line serial interface	
1 CAN interface for external communication	

**Necessary equipment**KIC2-standard connector **B 261 206 859**KIC2-diagnosis connector with  
ignition bridge **B 261 206 866**KIC2-diagnosis connector without  
ignition bridge **B 261 206 867****Cable harness connectors****D 261 205 139****D 261 205 140****Part number**MS 3.1 incl. Modas for notebook **B 261 208 245**

## Motronic MS 4 Sport

The MS 4 Sport is a highly sophisticated engine management system for high performance engines. The system contains 8 ignition drivers for external power stages and 8 independent injection power stages. Two independent wide range lambda circuits allow lambda closed loop engine control. Various engine parameters can be measured with different input channels and transferred via CAN interface to an optional flash card data logger. The MS 4 Sport is developed with EasyHandling software.



Mechanical data	
Sheet-metal housing	
Each connector pin individually filtered	
Vibration damped circuit boards	
Size	180 x 162 x 46 mm
Weight	430 g

Functionality	
Asymmetric injection timing possible	
Asymmetric ignition timing possible	
Dual lambda control	
Knock control (optional)	
Traction control (optional)	
Turbo functionality	
Electronic throttle control (optional)	
Support of 60-2 and 36-2 ignition trigger wheels	

Conditions for use	
Temperature range	-40 ... 75 °C
Max. power consumption	30 W at 14 V
Max. vibration	<i>Vibration Profile 2 (see Appendix)</i>

Electrical data	
<b>Inputs</b>	
2 inputs for exhaust gas temperature sensors	
2 lambda interfaces LSU	
4 inputs for Hall-effect wheel speed sensors	
1 input for inductive or Hall-effect crankshaft sensor	
16 universal inputs 0 ... 5 V	
2 inputs for vibration knock sensors	
7 digital inputs	
<b>Outputs</b>	
8 injection power stages	
8 ignition drivers	
20 power stages (2,7 A/0,6 A; low side; PWM)	
2 power stages for lambda heater	
1 H-bridge (5 A)	
2 sensor supply 5 V/100 mA	
<b>Communication interfaces</b>	
1 K-line serial interface	
2 CAN interfaces for external communication	

Part number	
MS 4 Sport	F 01T A20 049

## Motronic MS 4.0

The MS 4.0 is a highly sophisticated engine management system for high performance engines. The system contains 8 ignition drivers for external power stages and 8 independent injection power stages. Two vibration sensor inputs allow knock detection and knock control. Two independent wide range lambda circuits allow lambda closed loop engine control. Various engine parameters can be measured with different input channels and transferred via CAN interface to an optional flash card data logger.



Mechanical data	
Sheet-metal housing	
Each connector pin individually filtered	
Vibration damped circuit boards	
Size	180 x 162 x 46 mm
Weight	430 g

Functionality	
Injection timing	
Ignition timing	
Lambda control	
Knock control	
Traction control	
Turbo functionality	

Conditions for use	
Temperature range	-40 ... 75°C
Max. power consumption	30 W at 14 V
Max. vibration	<i>Vibration Profile 2 (see Appendix)</i>

Electrical data	
<b>Inputs</b>	
2 inputs for exhaust gas temperature sensors	
2 lambda interfaces LSU	
4 inputs for Hall-effect wheel speed sensors	
1 input for inductive or Hall-effect crankshaft sensor	
16 universal inputs 0 ... 5 V	
2 inputs for vibration knock sensors	
7 digital inputs	
<b>Outputs</b>	
8 injection power stages	
8 ignition drivers	
20 power stages (2,7 A/0,6 A; low side; PWM)	
2 power stages for lambda heater	
1 H-bridge (5 A)	
2 sensor supply 5 V/100 mA	
<b>Communication interfaces</b>	
1 K-line serial interface	
2 CAN interfaces for external communication	

Part number	
MS 4.0 incl. Modas	<b>B 261 208 300</b>

## Motronic MS 4.2

The MS 4.2 is a highly sophisticated engine management system for high performance engines. The system contains 8 ignition drivers for external power stages and 16 independent injection power stages. Various engine and chassis parameters can be measured with the different input channels and logged on the compact flash card data logger. Two vibration sensor inputs allow knock detection and knock control. Two independent wide range lambda circuits allow lambda closed loop engine control.



Mechanical data	
Dust and waterproof aluminium housing	
3 connectors in military technology with high pin density	
165 pins, each pin individually filtered	
Vibration damped circuit boards	
8 flexible housing fixation points	
Size	192 x 162 x 52 mm
Weight	1240 g

Conditions for use	
Temperature range	-40 ... 75 °C
Max. power consumption	30 W at 14 V
Max. vibration	<i>Vibration Profile 1 (see Appendix)</i>

Functionality	
Injection timing	
Ignition timing	
Lambda control	
Knock control	
Data acquisition	
Telemetry	
Traction control	
Turbo functionality	

Electrical data	
Inputs	
2 inputs for exhaust gas temperature sensors	
2 lambda interfaces LSU	
4 inputs for Hall-effect wheel speed sensors	
1 input for inductive or Hall-effect crankshaft sensor	
31 universal inputs 0 ... 5 V	
2 inputs for vibration knock sensors	
7 digital inputs	
Outputs	
16 injection power stages	
8 ignition drivers	
26 power stages (2,7 A/0,6 A; low side; PWM)	
2 power stages for lambda heater	
1 H-bridge (5 A)	
2 sensor supply 5 V/100 mA	
Communication interfaces	
1 RS232 serial interface	
2 K-line serial interfaces	
2 CAN interfaces for external communication	
1 SPI	
Compact Flash Card memory for data acquisition	

Part number	
MS 4.2 incl. Modas	<b>F 01E B01 638</b>

## Motronic MS 4.4 Sport

The MS 4.4 Sport is a highly sophisticated engine management system for high performance engines. The system contains 10 ignition drivers for external power stages and 10 independent injection power stages. Various engine and chassis parameters can be measured with the different input channels and logged on the external data logger. Four vibration sensor inputs allow knock detection and knock control. Two independent wide range lambda circuits allow lambda closed loop engine control. The MS 4.4 Sport is developed with EasyHandling software.



Mechanical data	
Dust and waterproof aluminium housing	
3 connectors in military technology with high pin density	
165 pins, each pin individually filtered	
Vibration damped circuit boards	
Size	174 x 133 x 39 (23) mm
Weight	859 g

Functionality	
Asymmetric injection timing possible	
Asymmetric ignition timing possible	
Dual lambda control	
Knock control (optional)	
Traction control(optional)	
Turbo functionality	
Electronic throttle control (optional)	
Support of 60-2 and 36-2 ignition trigger wheels	

Conditions for use	
Temperature range	-40 ... 75 °C
Max. power consumption	20 W at 14 V
Max. vibration	<i>Vibration Profile 1 (see Appendix)</i>

Electrical data	
<b>Inputs</b>	
1 input for inductive crankshaft sensor	
4 inputs for camshaft control	
4 inputs for Hall-effect wheel speed sensors	
2 lambda interfaces LSU 4.9	
39 inputs 0 ... 5 V (20 with switchable pullup)	
4 inputs for vibration knock sensors	
8 digital inputs	
<b>Outputs</b>	
10 injection power stages (2.2 A)	
10 ignition drivers for external power stages	
21 power stages (2.7 A/0.6 A; low side)	
2 power stages for lambda heater	
1 H-bridge (7 A)	
3 sensor supply 5 V/600 mA	
<b>Communication interfaces</b>	
1 K-line serial interface	
2 CAN interfaces for external communication	

Part number	
MS 4.4 Sport	F 01T A20 068

## Motronic MS 4.4

The MS 4.4 is a highly sophisticated engine management system for high performance engines. The system contains 10 ignition drivers for external power stages and 10 independent injection power stages. Various engine and chassis parameters can be measured with the different input channels and logged on the external data logger. Four vibration sensor inputs allow knock detection and knock control. Two independent wide range lambda circuits allow lambda closed loop engine control.



Mechanical data	
Dust and waterproof aluminium housing	
3 connectors in military technology with high pin density	
165 pins, each pin individually filtered	
Vibration damped circuit boards	
Size	174 x 133 x 39 (23) mm
Weight	859 g

Conditions for use	
Temperature range	-40 ... 75 °C
Max. power consumption	20 W at 14 V
Max. vibration	<i>Vibration profile 1 (see Appendix)</i>

Functionality	
Asymmetric injection timing possible	
Asymmetric ignition timing possible	
Dual lambda control	
Knock control	
Traction control	
Turbo functionality	
Electronic throttle control (optional)	
Support of 60-2 and 36-2 ignition trigger wheels	

Electrical data	
<b>Inputs</b>	
1 input for inductive crankshaft sensor	
4 inputs for camshaft control	
4 inputs for Hall-effect wheel speed sensors	
2 lambda interfaces LSU 4.9	
39 inputs 0 ... 5 V (20 with switchable pullup)	
4 inputs for vibration knock sensors	
8 digital inputs	
<b>Outputs</b>	
10 injection power stages (2.2 A)	
10 ignition drivers for external power stages	
21 power stages (2.7 A/0.6 A; low side)	
2 power stages for lambda heater	
1 H-bridge (7 A)	
3 sensor supply 5 V/600 mA	
<b>Communication interfaces</b>	
1 K-line serial interface	
2 CAN interfaces for external communication	

Part number	
MS 4.4	F 01T A20 040



## Motronic MS 5.2

The MS 5.2 is a 1 to 12 cylinder gasoline engine control for engine speeds up to 20.000 rpm. Design is based on our new digital core with a very high computing power and a high-end FPGA for additional performance and flexibility. The new software development process for this unit allows fast response times to algorithm changes. All software functions are designed, tested and simulated with MATLAB/Simulink. Code and documentation are generated automatically. The integration of individual customer functions is possible. The systems flexibility allows the support of any unusual engine configuration or chassis functionality.



### Mechanical data

Dust and waterproof aluminium housing	
4 connectors in military technology with high pin density	
220 pins, each pin individually filtered	
Vibration damped circuit boards	
Size	200 x 170 x 36.5 mm
Weight (approx.)	1250 g

### Conditions for use

Temp. range (at internal sensors)	-20 ... 85 °C
Approx. power cons. (w/o loads)	10 W at 14 V
Power Supply:	
Full operation	6,5 ... 18 V
Recommended	11 ... 14 V
Absolute maximum	6 ... 24 V
Max. Vibration	<i>Vibration Profile 1 (see Appendix)</i>

### Basic functionality

Injection timing
Ignition timing
Lambda control with adaptation function
Knock control
Traction control
Launch control
Gearcut function
Calibration interface: CCP via CAN or XCP via Ethernet
Interface to Bosch Data Logging System



Electrical data	
<b>Inputs</b>	
2 thermocouple exhaust gas temperature sensors	
2 lambda interfaces (LSU 4.9)	
1 crankshaft sensor (2-wire, inductive or Hall-effect)	
1 camshaft sensor (2-wire, inductive or Hall-effect)	
2 turbo speed sensors (2-wire, inductive or Hall-effect)	
4 wheel speed sensors (inductive or Hall-effect)	
2 gearbox speed sensors (inductive or Hall-effect)	
45 universal analog inputs 0 ... 5 V; 12 Bit	
14 analog inputs (angle synchronous or time synchronous triggering up to 250 ksps, 12 Bit)	
4 inputs for vibration knock sensors	
1 laptrigger input	
<b>Outputs</b>	
12 injection power stages (peak & hold)	
12 ignition drivers (up to 20A)	
16 power stages (2 A; low side; PWM)	
4 power stages (4 A; low side; PWM)	
4 H-bridge valve drivers (+/- 100 mA)	
2 H-bridges (5 A)	
3 sensor supplies 5 V/400 mA and 1x 10 V/100 mA	
6 diagnostic outputs with selectable internal signals	
12 outputs with configurable function (FPGA)	
1 timebase synch-in/out	
<b>Communication interfaces</b>	
2 x 100 Mbps Ethernet interfaces	
1 x RS232 serial interface	
4 x 1 Mbps CAN interfaces	

Part Number	
MS 5.2	<b>F 01T A20 069 01</b>

# Motronic MS 15.1

The MS 15.1 is an ECU for Diesel engines with up to 8 cylinders. It is developed for the combination with Bosch solenoid injectors.



Mechanical data	
Dust and waterproof aluminium housing	
4 connectors in military technology with high pin density, 187 pins	
Vibration damped circuit boards	
8 flexible housing fixation points	
Size	210 x 36 x 199 mm
Weight	1780 g

Conditions for use	
Temperature range	-40 ... 75°C
Typical power consumption	140 W at 14 V
Max. vibration	<i>Vibration profile 1 (see Appendix)</i>

Functionality	
Injection timing:	
2 pilot injections	
2 main injection	
1 post injection	
Lambda measurement	
Data acquisition, external Logger C55	
Telemetry (external unit FM40 in combination with data logger C55)	
Traction control (optional)	
Basic functionality for up to two turbochargers in parallel mode	
Gear cut for sequential gearbox	
Speed limiter	
Optional function packages available	

Electrical data	
<b>Inputs</b>	
2 inputs for thermocouple exhaust gas temp. sensors	
2 lambda interfaces LSU	
4 inputs for wheel speed sensors; basic design for inductive sensors	
4 inputs for turbo speed sensors; basic design for inductive sensors	
1 input for inductive crankshaft sensor	
1 input for Hall-effect camshaft sensor	
3 system inputs 0 ... 5 V	
13 universal inputs 0 ... 5 V, fixed pull-up	
27 universal inputs 0 ... 5 V, switchable pull-up	
3 digital inputs	
<b>Outputs</b>	
8 injection power stages	
12 power stages (low side)	
2 power stages for lambda heater	
2 H-bridge	
2 sensor supply 5 V/ system use	
3 sensor supply 5 V/300 mA	
3 sensor supply 10 V/100 mA	
<b>Communication interfaces</b>	
1 RS232 serial interface	
1 K-line serial interface	
3 CAN interfaces (dash, application, customer use)	
2 firewire interfaces for external communication	
<b>Part number</b>	
MS 15.1 solenoid injector	<b>F 01T A20 022</b>

## Motronic MS 15.2

The MS 15.2 is an ECU for Diesel engines with up to 6 cylinders. It is developed for the combination with Bosch piezo injectors.



Mechanical data	
Dust and waterproof aluminium housing	
4 connectors in military technology with high pin density, 187 pins	
Vibration damped circuit boards	
8 flexible housing fixation points	
Size	210 x 36 x 199 mm
Weight	1780 g
Conditions for use	
Temperature range	-40 ... 75°C
Typical power consumption	140 W at 14 V
Max. vibration	<i>Vibration Profile 1 (see Appendix)</i>
Functionality	
Injection timing:	
2 pilot injections	
1 main injection	
1 post injection	
Lambda measurement	
Data acquisition, external Logger C55	
Telemetry (external unit FM40 in combination with data logger C55)	
Traction control (optional)	
Basic functionality for up to two turbochargers in parallel mode	
Gear cut for sequential gearbox	
Speed limiter	
Optional function packages available	

Electrical data	
Inputs	
2 inputs for thermocouple exhaust gas temp. sensors	
2 lambda interfaces LSU	
4 inputs for wheel speed sensors; basic design for inductive sensors	
4 inputs for turbo speed sensors; basic design for inductive sensors	
1 input for inductive crankshaft sensor	
1 input for Hall-effect camshaft sensor	
3 system inputs 0 ... 5 V	
13 universal inputs 0 ... 5 V, fixed pullup	
27 universal inputs 0 ... 5 V, switchable pullup	
3 digital inputs	
Outputs	
6 injection power stages	
12 power stages (low side)	
2 power stages for lambda heater	
2 H-bridges	
2 sensor supply 5 V/ system use	
3 sensor supply 5 V/300 mA	
3 sensor supply 10 V/100 mA	
Communication interfaces	
1 RS232 serial interface	
1 K-line serial interface	
3 CAN interfaces (dash, application, customer use)	
2 firewire interfaces for external communication	
Part number	
MS 15.2 Piezo injector	<b>F 01T A20 023</b>

# Displays

## Display DDU Sport

The DDU Sport is a light and compact dashboard unit with a high contrast display. Customised display configurations can be programmed to suit individual customer requirements. All illuminated components are dimmable.

For enhanced flexibility the DDU Sport can be interfaced to a range of stand-alone I/O modules that provide the driver with additional information or alternatively enable the driver to interface with multiple vehicle functions.

The display has an integrated logger with a memory capacity of 512 MB. Data acquisition and application software RaceLab Sport and one set of connectors are inclusive.



Mechanical data	
Dimensions	160 x 110 x 26 mm
Weight	433 g

Display	
LCD display / LED background light	
Active area	91 x 56 mm
Resolution	240 x 128
Dot size	0,38 x 0,41 mm
	4 programmable pages
Mounting	4 x M5 threads on backside

Conditions for use	
Max. Vibration	<i>Vibration Profile 1 (see Appendix)</i>
Temperature	-10 ... 65 °C

Switches	
4 internal switches for operation (pages, mode, setting), available also on backside connectors	

Electrical data	
7 sequential shift LEDs	
512 Mbyte Data logger	
4 analogue input (0-5 V) 10 bit resolution	
4 digital input (HL = 2,5 – 32 V)	
Real Time Clock	
2 x CAN-Bus	
1 x 100 Mbit LAN	
Voltage supply range: 7,5 – 35 V	
Sensor supply: 5 V, 500 mA	
Data acquisition and application software RaceLab Sport inclusive	

Connector	
Binder 712	

Part number	
DDU Sport	<b>F 01T A20 050</b>

## Display DDU 4

The DDU 4 is a light and compact dashboard unit with a high contrast colour display. Up to 12 customised display pages can be programmed to suit individual customer requirements. All illuminated components are dimmable.

Mathematic functions and alarms can be programmed and linked to values and LEDs.

Using the new CAN interface the DDU4 can be connected to any ECU.



Mechanical data	
Dimensions	164 x 117 x 37 mm
Weight	753 g

Display	
1x active matrix TFT high contrast colour display	
Active area	111 x 83 mm
Resolution	320 x 240
Dot size	0,116 x 0,348 mm

Conditions for use	
Max. Vibration	<i>Vibration Profile 1 (see Appendix)</i>
Temperature	-10 ... 75 °C
Display panel with optical double-sided antiglare coating for highest contrast and display accuracy	

Electrical data	
1 x CAN interface for communication with ECU via CCP and free configurable for any ECU messages	
5 LED shift indicators (5 drivers, open collector, 2.2 A)	
10 LED multi purpose indication lights	
Dedicated battery voltage measurement	
Programming over MSA-Box (USB)	

Holders	
Aluminium	<b>F 01E B01 457</b>
Carbon fibre	<b>F 01E B01 458</b>

Switches	
External switches for display position and dimming of display and LEDs	<b>B 261 209 659</b>

Programming interface	
MSA-Box (USB)	<b>B 261 208 015</b>

Part number	
DDU 4 incl. cable, without holder	<b>F 01E B01 461</b>

## Display DDU 6

The DDU 6, exclusively developed for Bosch Motorsport ECUs, is a light and compact, steering wheel mounted dashboard unit. It is equipped with a high contrast colour display. Up to 12 customised display configurations can be programmed to suit individual customer requirements. All illuminated components are dimmable.

For enhanced flexibility the DDU 6 can be interfaced to a range of stand-alone I/O modules that facilitate multiple functions like switching, light indication, car and race information display.



### Mechanical data

Dimensions	165 x 104 x 32 mm
Weight	342 g

### Display

1x active matrix TFT high contrast colour display	
Active area	54 x 72 mm
Resolution	240 x 320

### Conditions for use

Max. Vibration	<i>Vibration profile 1 (see Appendix)</i>
Temperature	-10 ... 65 °C

### Electrical data

1 x CAN interface for communication with ECU via CCP and free configurable for any ECUs messages
1 x CAN interface for communication with network
1 x RS 232 interface for display programming
5 LED shift indicators
4 LED warning lights
6 inputs 0 ... 5 V (analog/digital)

### Part number

DDU 6	<b>F 01E B01 459</b>
-------	----------------------

# Communication



# Data Logging and Signal Processing

## Data Logger C Sport

The data logger C Sport is a device used for data acquisition. It is developed to read in analogue and digital signals. The measured data are stored on an internal 512 MB memory. The data are transmitted with RaceLab Sport via Ethernet to the data logger C Sport.

Acquisition and application software RaceLab Sport and one set of connectors are inclusive.



Mechanical data	
Size	102 x 62 x 27 mm
Weight	210 g
Required power supply	7,5 ... 35 V
Dust and splash waterproof aluminium housing	
Flexible housing fixation points	

Conditions for use	
Temperature range	-20 ... 65 °C
Max. power consumption	4 W at 14 V
Max. vibration	<i>Vibration Profile 1 (see Appendix)</i>

Connector	
	4 x Binder 712

Electrical data	
1 CAN Bus link (ECU)	
1 CAN Bus link (to cascade C Sport or attach DDU Sport)	
1 Ethernet connector (for PC connection)	
512 MB internal memory	
Real time clock	
Total calculation capacity approximately 10 MIPS	
4 digital inputs	
4 analog single ended inputs 16 bit resolution	
4 analog differential inputs 16 bit resolution	
1 digital output	
Data acquisition and application software RaceLab Sport inclusive	

Part number	
C Sport	<b>F 01T A20 061</b>

## CardMemory C40 / C40 Plus

The CardMemory is a device used for data logging. The basic model C40 is designed for data transfer via CAN for MS3.x and MS4.x ECUs. The extended model C40 Plus is developed to read in additional 15 analog signals and 1 rev signal. The measured data are stored on a compact flash card.



Mechanical data	
Dust and splashwater proof aluminium housing	
Flexible housing fixation points	
Connector	with 5 or 40 pins
Size	150 x 90 x 22 mm
Weight	330 g

Conditions for use	
Ecu temperature	-40 ... 75 °C
Max. power consumption	7 W at 14 V
Max. vibration	15 g sinus at 20 Hz ... 2 kHz for t < 5 h

Electrical data	
1 microcontroller with 16 bit organisation	
1 CAN interface	
Real time clock	
Non volatile flash card memory	
Total calculation capacity approximately 10 MIPS	

Options	
15 analog inputs with 10 bit resolution and 5 ms sample rate time (only C40 Plus)	
1 inductive crankshaft sensor interface	
Sensor supply outputs	5 V/100 mA 10 V/100 mA
Calibration functions are realised with an additional software tool	

Necessary equipment	
Flash card 128 MB	F 01E B01 105_0B
Flash card 256 MB	F 01E B01 106_0B
Flash card 512 MB	F 01E B01 107_0B
Flash card 1024 MB	F 01E B01 108_0B
Flash card 2048 MB	F 01E B01 109_0B
Memory adapter	B 261 206 864
C40 adapter cable	B 261 209 433

Connector	
Cable harness connector C40	AS0-14-35 SN
Cable harness connector C40 Plus	AS0-14-35 SN

Part numbers	
C40	F 01T A20 403
C40 Plus	B 261 206 860
C40 Plus incl. chassis adjust	B 261 206 880
Upgrade C40 to C40 Plus	on request
Software chassis adjust	on request

## Data Logging Accessories

Compact flash cards, adapters and drivers are necessary to use the Card memory. For some optional functions additional cables and software are on offer.

Compact flash cards are offered with a storage capacity of up to 2048 MB. The compact flash card adapter is used to insert the card to the PCMCIA slot of the PC for data download and card formatting.

In conjunction with the memory C40 Plus, a software tool for additional calibration functions is offered. Together with an individual cable harness it is possible to calibrate further sensors for chassis data logging. To connect memory C40 to the vehicle cable harness the special C40 adapter cable is necessary.



Conditions for use	
Operating temperature	-40 ... 84°C
Humidity	5 % to 95 %, non condensing
Vibration	15 g peak to peak
Shock	max. 2,0 g

Part numbers	
Flash card 128 MB	F 01E B01 105_0B
Flash card 256 MB	F 01E B01 106_0B
Flash card 512 MB	F 01E B01 107_0B
Flash card 1024 MB	F 01E B01 108_0B
Flash card 2048 MB	F 01E B01 109_0B
Memory adapter	B 261 206 864
Flash card adapter	B 261 205 814
Software Chassis Adjust	B 261 206 870
C40 adapter cable	B 261 209 433

# Data Logging System DLS

## System

The Data Logging System (DLS) is a many-sided and flexible measuring system for acquisition and recording of sensor data in a race car. The measuring channels in the DLS can be administered comfortably and can be adapted individually for every race car. The DLS is a modular system that consists of different hard- and software components.

## Hardware

The hardware serves the data acquisition and the recording of physical data in the vehicle. The data logger (CardMemory) and the data acquisition (MSI devices) which delivers the sensor data to the data logger belong to the hardware components. Additional data transfer takes place via burst or via online telemetry.

## Software

The software allows the real configuration and consequently the adjustment of the system. It enables you to create measuring projects, to check data, to record measuring channels and to analyse the measuring channels.

DLS components	
Datalogger, System manager	C 55
Burst telemetry	BT 55, BR 55
Online telemetry	FM40
Modular Sensor Interface	MSI 55
Extended CAN Modules	EM-50, EM-100, EM-I4 EM-L5, EM-O5, EM-C, EM-D8, EM-D1, EM-A6, EM-H4,
DLS configuration Software	DLS-Desk
System Software	WinDCP, Modas, WinDarab

Technical details
High measuring accuracy by 12 bits of analogue / digital transformation and tenfold oversampling
High recording rate up to 1 ms
High recording duration by CF card up to 2 GB
High-linear analogue filtering and digital filtering for the removal of interference signals.
Flexibly with the extensibility of the components and measuring channels
Temporal synchronisation between the different measuring channels
Connectivity and data transfer via telemetry
Free and individual application by special software

## CardMemory C 55

The CardMemory C55 is a device used for data logging and DLS system management. The measured data are stored on a compact flash card with a maximum capacity of 1024 MB.



Mechanical data	
Size	157 x 92 x 30 mm
Weight	500 g
Dust and splashwater proof aluminium housing	

Conditions for use	
ECU temperature	-20 ... 65 °C
Max. power consumption	20 W at 14 V
Max. vibration	<i>Vibration profile 1 (see Appendix)</i>

Electrical data	
1 CAN interface	
2 Fire wire interfaces	
2 Ethernet interfaces	
Real time clock	
Non volatile flash card memory	

Additional equipment	
Flash card 256 MB	F 01E B01 106_0B
Flash card 512 MB	F 01E B01 107_0B
Flash card 1024 MB	F 01E B01 108_0B
Memory adapter	B 261 206 864

Documents	
Dimension sheet	Y261A25051.pdf
3D model	Y261A25051.stp
Data sheet	F01EB01630.xls

Part number	
CardMemory C 55	F 01E B01 630

## Modular Sensor Interface MSI 55

The MSI 55 is a high quality data acquisition of analog and digital sensors.

The MSI 55 offers 16 configurable analog inputs, 4 frequency inputs, 2 digital I/O and a freely configurable 1 MBit CAN Bus. Data is sent via FireWire interface to the C 55 datalogger.



Mechanical data	
Size	120 x 117 x 38 mm
Weight	600 g
Dust and water proof aluminium housing	
Filtered connectors of military design with high pin density (MIL-38999)	
Vibration damped printed circuit boards	

Conditions for use	
ECU temperature	-20 ... 65 °C
Max. power consumption	20 W at 14 V
Max. vibration	15 g sinus at 1.200 Hz for t < 5 h

Electrical data	
16 bit digital signal process organisation, calculation power 150 MIPS	
Required power supply	8 ... 18 V
4 differential analog inputs with switchable amplifier and switchable pullup resistor	
12 single analog inputs with switchable pullup resistor	
All analogue inputs offer analog and digital anti-aliasing filter and 12 bit AID resolution	
4 frequency inputs 0 ... 25,5 kHz switchable inductive sensor / Hall-effect sensor	
2 digital I/O	
2 PWM outputs 100 mA	
5 V sensor power supply	
3 ... 10 V configurable sensor power supply	
12 V sensor power supply	

Documents	
Dimension sheet	Y261A21876.pdf
3D model	Y261A21876.stp
Data sheet	F01TA20024.xls

Part number	
MSI 55	F 01T A20 024

## Burst Telemetry Transmitter BT 55

The burst telemetry system BT 55 / BR 55 adds high speed burst telemetry transmission to a DLS-based data acquisition system. Each time the car passes the pit lane, up to 6 MByte of C 55 measurement data can be transmitted to the Pit network via a WiFi band high speed wireless link.



Mechanical data	
Size	168 x 92 x 30 mm
Weight	540 g
Dust and waterproof housing with LED indicators	

Conditions for use	
Vibration	15 g sinus at 1200 Hz for t < 5h
Temperature range	-20 ... 65 °C
Max. power consumption	20 W at 14 V
International standard	IEEE 802.11b

Electrical data	
Full duplex radio modem (bidirectional)	
Transmission power	100 mW
Frequency range	2,4 GHz ISM Band
Data rate	max. 11 MBit/s
Required power supply	8 ... 18 V
Max. current	< 2,5 A

Documents	
Dimension sheet	<a href="#">A261208899.pdf</a>
3D model	<a href="#">A261208899.stp</a>
Data sheet	<a href="#">B261208899.xls</a>

Part number	
BT 55	<b>B261 208 899</b>

## Lambdatronic LT4

The Lambdatronic LT4 provides controlled pumping current to supply up to 4 Bosch (Mini)-LSU 4.9. The lambda value, the sensor temperature and diagnostics are available via CAN and analogue signal.

The LSU contains a Nernst and a pump cell. The lambda in the Nernst cell is controlled to  $\lambda = 1.013$  independent of the oxygen contents on the emission side, through a current through the pump cell. The current proportional output voltage of the IC is a measure of the lambda value. The unit can be configured by the included software MODAS.

The main feature and benefit of this unit is the combination of the Bosch well known lambda IC and a very compact box size with military specification. Furthermore the analogue signal output can be configured freely.



Application	
Application	0,75 ... 10,12 lambda
Compatible Sensor Type	Bosch (Mini-)LSU 4.9
Nr. of Channels	4
Heater	internal
Operating Temp Range (housing)	-20 ... 85 °C
Storage Temperature Range	-20 ... 85 °C
Application SW	MODAS V3
Communication Link	K-Line / CAN

Electrical Data	
Power Supply $U_s$	(6,5) 10 ... 17 V
Max Power Supply (1 min) $U_{smax}$	26 V
Thermal Dissipation Loss	3 W @ 14 V
Current $I_s$	5 A
Current $I_s$ (Heating up)	26 A

Mechanical Data	
Weight with Cable	98 g
Sealing	100 % humidity
Fixation	Velcro
Size w/o Calbe (w*h)	54 x 59 x 13 mm
Max. Vibration	<i>Vibration Profile 1 (see Appendix)</i>

Characteristic	
Signal Output 1	CAN
Signal Output 2	4 x 0... 5 V
CAN- Baudrate	1 Mbaud
Signal Resolution	$2,5 * 10^{-4}$ lambda
Signal Sampling Rate	100 Hz
CAN Refresh Rate	100 Hz



**Connectors and Cable**

Connector	AS 6-14-35PN
Connector Loom	AS 1-14-35SN
Sleeve	Viton
Cable Size	26
Cable Length L	20 cm

**Application Hint**

The LT4 is designed to supply 4 Bosch (Mini)-LSU 4.9.

The unit can be connected to any CAN system (1 Mbaud) and analog measuring device.

To avoid signal errors, a cable length of maximum 1,5 m between sensor and box is recommended.

The unit is secure from miss-pinning.

The reference ground (GND\_REF) has to be connected either to the measuring device or to the system ground.

A ground offset of 2 V (max) between GND and GND\_REF has not to be exceeded.

See the LT4 function manual for software documentation (CAN protocol e.g.).

Please find further application hints in the offer drawing (<http://www.bosch-motorsport.com>).

**Part number**

Lambdatronic LT4

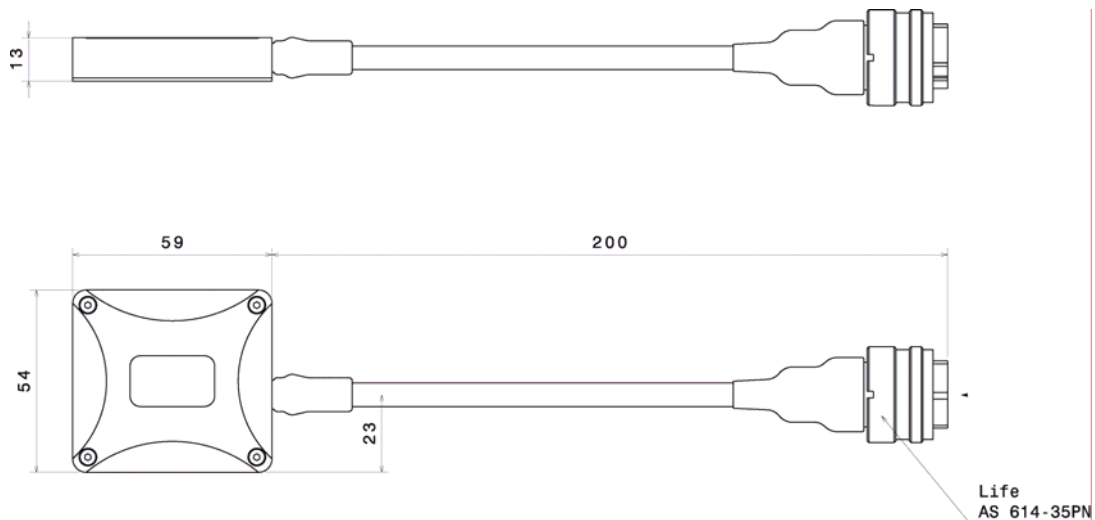
**F 01T A20 070\_02**

Pin	Function
1	UBAT
2	UBAT
3	GND
4	GND
5	B_D_DIAK
6	B_D_CAN1_H
7	B_D_CAN1_L
8	A_A_UA1
9	A_A_UA2
10	A_A_UA3
11	A_A_UA4
12	GND_REF
13	M_C_GND
14	E_A_LSUIP1
15	M_R_LSUVM1
16	A_S_LSH1
17	U_U_LSUH1
18	E_A_LSUIA1
19	E_A_LSUUN1

Pin	Function
20	E_A_LSUIP2
21	M_R_LSUVM2
22	A_S_LSH2
23	U_U_LSUH2
24	E_A_LSUIA2
25	E_A_LSUUN2
26	E_A_LSUIP3
27	M_R_LSUVM3
28	A_S_LSH3
29	U_U_LSUH3
30	E_A_LSUIA3
31	E_A_LSUUN3
32	E_A_LSUIP4
33	M_R_LSUVM4
34	A_S_LSH4
35	U_U_LSUH4
36	E_A_LSUIA4
37	E_A_LSUUN4

## AWS LSU 4.9

The AWS LSU 4.9 is used in combination with the lambda sensor Mini-LSU 4.9. The box supplies two LSU 4.9 lambda probes. It includes two heaters and converts each specific sensor signal into two separate lambda signals. Furthermore, the temperature of the sensor, the duty cycle of the heater and diagnosis of the probe is available. The signal output is via CAN-message.



Mechanical data	
Weight	80 g
Size	38 x 43 x 16 mm
Cable length	150 mm

Conditions for use	
Operating temperature	10 ... 60 °C

Diagnosis	
$\lambda_{\text{Value}} = 0,0069$ :	failed sensor (short cut or not connected)
$\lambda_{\text{Value}} = 0,0686$ :	probe did not reach 600 °C (up to 30 sec)
$\lambda_{\text{Value}} = 0,1373$ :	heating periode

Electrical data	
Power supply	5 ... 20 V
Rent consumption	120 mA at 12 V + heater current (max. 2 A per probe)
Channels	2 A/F
Resolution	0,01
Sampling rate	100 Hz per channel

CAN-ID								
For each probe, the following CAN-IDs will receive the A/F value as <b>16-bit unsigned Integer</b> and the heating value and the temperature values as <b>8-bit unsigned byte</b> (Motorola-type):								
CAN-ID	Byte 0	Byte 1	Byte 2	Byte 3	Byte 4	Byte 5	Byte 6	Byte 7
0x290	A/F1		A/F2		Temp1	Temp2	Heat1	Heat2
A/F <sub>Value</sub>		= 0,001 * A/F <sub>x</sub>						
$\lambda_{\text{Value}}$		= A/F <sub>Value</sub> / 14,57 = A/F <sub>Digits</sub> / 14570 = A/F <sub>Digits</sub> * 0,00006863418						
Heat-Temp		= Temp <sub>x</sub> <sub>Digits</sub> * 2 + 496,9 °C						

Part number
F 01E B01 622

# CAN Module EM-A6

## 6 analog Channels

The extended module EM-A6 measures up to 6 analog channels, converts the values to an 8 bit format and combines them to a CAN-Message. The module has a CAN-Interface (CAN2.0 B) which is used for transmitting the information from and to the module.

Weight and space required for the wiring harness can be reduced by daisy-chaining multiple extended modules because power and communication lines are routed through the device.



### Mechanical Data

Size 155,0 x 38,0 x 32,1 mm

### Conditions for Use

Operating Temperature -20 °C ... 85 °C

Max. Vibration *Vibration Profile 1 (see Appendix)*

### Power Supply

10 V ... 18 V

Supply Current (without load) max. 80 mA

ADC accuracy ±20 mV

### Communication/Configuration Interface

CAN2.0 B, using interface MSA-Box and RaceCon

Programmable CAN-ID

Switchable software pull-ups

### Loomside Connector

Deutsch ASL606-05PN-HE red

Deutsch ASL606-05PD-HE green

Deutsch ASL606-05SN-HE red

### Connector ASL206-05SN-HE (red); ANAx

Pin-No.	Function
1	UB_SG
2	AGND
3	ANA_INx
4	Vref50
5	N/C

### Connector ASL206-05SD-HE (green), XOUT

Pin-No.	Function
1	UBATT
2	GND
3	CAN-Hi
4	CAN-LO
5	GND

### Connector ASL206-05PN-HE (red), XIN

Pin-No.	Function
1	UBATT
2	GND
3	CAN-Hi
4	CAN-LO
5	GND

### Part Number

CAN Module EM-A6 **F 01T A20 007**

## CAN Module EM-C

### Module for programming ALWS

The extended EM-C module displays the current angle of the camshaft that is measured by the Bosch camshaft angle sensor LWS4 and transmitted via CAN. The EM-C module receives this message and displays the angle (-180° ... +180°) in its bright red dot-matrix display.

Moreover, the EM-C module features a reset-button which, during the engine assembly, enables the engine builder to precisely set the LWS4 sensor reference to “zero” when the camshaft is at the desired “zero” position. The module has a 500 kBaud CAN-Interface (CAN2.0 B) which is used for transmitting the information from and to the module.

The module is delivered with a connection adapter between housing and connector.



#### Mechanical Data

Size 94,2 x 30,0 x 24,2 mm

#### Conditions for Use

Max. Vibrations *Vibration Profile 1 (see Appendix)*

#### Power Supply

8 V ... 18 V

Supply Current  
(100 % brightness, dots on) max. 300 mA

#### Communication/Configuration Interface

CAN2.0 B, using interface MSA-Box and RaceCon

Programmable CAN-ID

#### Loomside Connector

AS6-06-05SN-HE

#### Connector ASL-006-05PN-HE

Pin-No.	Function
1	UBATT
2	GND
3	CAN-Hi
4	CAN-LO
5	N/C

#### Part Number

CAN Module EM-C **F 01T A20 025**

# CAN Module EM-D1

## Large, single Character

The extended module EM-D1 displays 1 character of arbitrary information on a large bright red dot-matrix display with 16 intensity levels. The module has a CAN-Interface (CAN2.0 B) which is used for transmitting the information from and to the module.

Weight and space required for the wiring harness can be reduced by daisy-chaining multiple extended modules because the power and communication lines are routed through the devices (2 connectors option only).

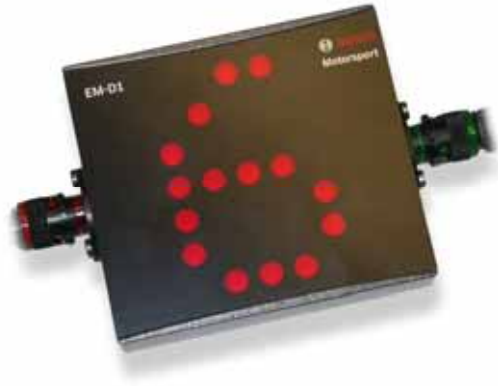

### Mechanical Data

Size 69,45 x 62,45 x 16,83 mm

### Conditions for Use

Operating Temperature -20 °C ... 85 °C

Max. Vibration *Vibration Profile 1 (see Appendix)*

### Power Supply

8 V ... 18 V

Supply Current (100 % brightness, dots on) max. 395 mA

### Communication/Configuration Interface

CAN2.0 B, using interface MSA-Box and RaceCon

Programmable CAN-ID and characters

### Loomside Connector

AS-6-10-35SN-HE (red)

AS-6-03-05PD-HE (green)

### Input Connector ASU-0-03-05PN-HE (red)

Pin-No.	Function
1	UBATT
2	GND
3	CAN-Hi
4	CAN-LO
5	N/C

### Output Connector ASU-0-03-05SD-HE (green)

Pin-No.	Function
1	UBATT
2	GND
3	CAN-Hi
4	CAN-LO
5	N/C

Note that ASU-0-03-05PN-HE is the default connector on every device while ASU-0-03-05SD-HE is an optional extra connector if daisy chaining of devices is intended.

### Part Number

CAN Module EM-D1 **F 01T A20 006**

# CAN Module EM-D8

## 8 Characters

The extended module EM-D8 displays up to 8 characters of arbitrary information on a bright red dot-matrix display. The module has a CAN-Interface (CAN2.0 B) which is used for transmitting the information from and to the module.

Weight and space required for the wiring harness can be reduced by daisy-chaining multiple extended modules because the power and communication lines are routed through the devices (2 connectors option only).



### Mechanical Data

Size 85,4 x 32,3 x 17,1 mm

### Conditions for Use

Operating Temperature -20 °C ... 85 °C

Max. Vibration *Vibration Profile 1 (see Appendix)*

### Power Supply

8 V ... 18 V

Supply Current (100 % brightness, dots on) max. 300 mA

### Communication/Configuration Interface

CAN2.0 B, using interface MSA-Box and RaceCon

Programmable CAN-ID

Programmable text message

### Loomside Connector

Deutsch AS-6-03-05SN-HE (red)

Deutsch AS-6-03-05PD-HE (green)

### Input Connector ASU-0-03-05PN-HE (red)

Pin-No.	Function
1	UBATT
2	GND
3	CAN-Hi
4	CAN-LO
5	N/C

### Output Connector ASU-0-03-05SD-HE (green)

Pin-No.	Function
1	UBATT
2	GND
3	CAN-Hi
4	CAN-LO
5	N/C

Note that ASU-0-03-05PN-HE is the default connector on every device while ASU-0-03-05SD-HE is an optional extra connector if daisy chaining of devices is intended.

### Part Number

CAN Module EM-D8 **F 01T A20 004**

# CAN Module EM-H4

## 4 Hall speeds

The extended module EM-H4 acquires the signal periods of up to 4 Hall-effect speed sensors and transmits them as 16-bit values with 3,2us quantization to a CAN-Interface (CAN2.0 B) in a single CAN-message.

The module is delivered with an adapter between housing and connector.



Mechanical Data	
Size	85,4 x 32,3 x 17,1 mm

Conditions for Use	
Max. Vibration	<i>Vibration Profile 1 (see Appendix)</i>

Power Supply	
8 V ... 18 V	
Supply Current	max. 70 mA

Electrical Data	
Input	10 ... 10000 impulses/s

Communication/Configuration Interface	
CAN2.0 B, using interface MSA-Box and RaceCon	
Programmable CAN-ID and CAN Speed	

Loomside Connector	
AS-6-10-35SN-HE	

Connector AS-0-10-35PN-HE	
Pin-No.	Function
1	UBATT
2	GND
3	N/C
4	CAN-Hi
5	CAN-LO
6	VL
7	VR
8	HL
9	HR
10	GND
11	SHIELD
12	N/C
13	N/C

Part Number	
CAN Module EM-H4	<b>F 01T A20 008</b>



## CAN Module EM-I4

### 4 inductive speeds

The extended module EM-I4 acquires the signal periods of up to 4 inductive speed sensors and transmits them as 16-bit values with 3,2us quantization to a 1 Mbaud CAN-Interface (CAN2.0 B) in a single CAN-message.

The Module is delivered with an adapter between housing and connector.



Mechanical Data	
Size	85,4 x 32,3 x 17,1 mm

Conditions for Use	
Operating Temperature	-20 °C ... 85 °C
Max. Vibration	<i>Vibration Profile 1 (see Appendix)</i>

Power Supply	
8 V ... 18 V	
Supply Current	max. 70 mA

Communication/Configuration Interface	
CAN2.0 B, using interface MSA-Box and RaceCon	
Programmable CAN ID	

Electrical Data	
Input	10 to 10 000 impulses/s

Loomside Connector	
Deutsch AS-6-10-35SN-HE	

Connector AS-0-10-35PN-HE	
Pin-No.	Function
1	UBATT
2	GND
3	N/C
4	CAN-Hi
5	CAN-LO
6	VL
7	VR
8	HL
9	HR
10	GND
11	SHIELD
12	N/C
13	N/C

Part Number	
CAN Module EM-I4	<b>F 01T A20 009</b>

# CAN Module EM-L5

## 5 LEDs

The extended module EM-L5 uses 5 ultra bright LED lights with 16 user selectable levels of intensity to display the gear shift request signal from the ECU to the driver. The module has a 1 Mbaud CAN-Interface (CAN2.0 B) which is used for transmitting the information from and to the module.

Weight and space required for the wiring harness can be reduced by daisy-chaining multiple extended modules because the power and communication lines are routed through the devices (2 connector option only).



### Mechanical Data

Dimensions 85,4 x 32,3 x 17,1 mm

### Conditions for Use

Operating Temperature -20 °C ... 85 °C

Max. Vibration *Vibration Profile 1 (see Appendix)*

### Power Supply

10 V ... 15 V

Supply Current (100 % brightness, all LEDs on) max. 200 mA

### Communication/Configuration Interface

CAN2.0 B, using interface MSA-Box and RaceCon

Programmable CAN-ID

Programmable thresholds for LEDs gear dependant

### Loomside Connector

Deutsch ASU-6-03-05PN-HE (red)

Deutsch ASU-6-03-05SD-HE (green)

### Input Connector ASU-0-03-05PN-HE (red)

Pin-No.	Function
1	UBATT
2	GND
3	CAN-Hi
4	CAN-LO
5	N/C

### Output Connector ASU-0-03-05SD-HE (green)

Pin-No.	Function
1	UBATT
2	GND
3	CAN-Hi
4	CAN-LO
5	N/C

Note that ASU-0-03-05PN-HE is the default connector on every device while ASU-0-03-05SD-HE is an optional extra connector if daisy chaining of devices is intended.

### Part Number

CAN Module EM-L5 **F 01T A20 002**

# CAN Module EM-P5

## 5 low Power Outputs

The extended module EM-P5 has 5 open collector outputs and is used to switch small loads. Each of these output stages can drive a maximum load current of 100 mA. The module has a 1 Mbaud CAN-Interface (CAN2.0 B) for the signal input.

The module is delivered with a Y-connection adapter.



Mechanical Data	
Size	85,4 x 32,3 x 17,1 mm

Conditions for Use	
Operating Temperature	-20 °C ... 85 °C
Max. Vibration	<i>Vibration Profile 1 (see Appendix)</i>

Power Supply	
8 V ... 18 V	
Supply Current (100 % brightness, all LEDs on)	max. 50 mA

Communication/Configuration Interface	
CAN2.0 B, using interface MSA-Box and Racecon	
Programmable CAN ID	
Programmable Thresholds and hysteresis for each output	

Loomside Connector	
Deutsch ASU-0-03-05PN-HE (red)	
Deutsch ASU-0-03-05SD-HE (green)	

Input Connector ASU-0-03-05PN-HE (red)	
Pin-No.	Function
1	UBATT
2	GND
3	CAN-Hi
4	CAN-LO
5	N/C

Output Connector ASU-0-03-05SD-HE (green)	
Pin-No.	Function
1	L1(Open collector output)
2	L2(Open collector output)
3	L3(Open collector output)
4	L4(Open collector output)
5	L5(Open collector output)

Note that both connectors are at the end of the connection adapter.

Part Number	
CAN Module EM-P5	<b>F 01T A20 003</b>

# CAN Module EM-25, EM-50, EM-100

## CAN Converter

The extended modules EM-25, EM-50 and EM-100 are used to connect two CAN-Buses operating on different baud rates (EM-25 and EM-50) or alternatively as a repeater device with long CAN-Bus harness. Assignment of the three devices to their baud rate converting capability is shown below:

Devices	
<b>EM-25</b>	converts 250 kBaud to 1 MBaud
<b>EM-50</b>	converts 500 kBaud to 1 MBaud
<b>EM-100</b>	converts 1 MBaud to 1 MBaud

These are the standard devices. However, different converting capabilities are available on request.

All these extended modules feature robust light weight aluminium housing and military connectors designed to withstand the harsh motor sport environment.

Mechanical Data	
Size	85,4 x 32,3 x 17,1 mm

Conditions for Use	
Max. Vibration	<i>Vibration Profile 1 (see Appendix)</i>



Input Connector ASU-0-03-05PN-HE (red)	
Pin-No.	Function
1	UBATT
2	GND
3	CANI-Hi
4	CANI-LO
5	N/C

Output Connector ASU-0-03-05SD-HE (green)	
Pin-No.	Function
1	UBATT
2	GND
3	CANO-Hi
4	CANO-LO
5	N/C

Communication/Configuration Interface	
CAN2.0 B	

Power Supply	
8 V ... 18 V	
Supply Current (min. supply voltage, max. bus load)	max. 120 mA

Part Numbers	
EM-25	<b>F 01T A20 047</b>
EM-50	<b>F 01T A20 027</b>
EM-100	<b>F 01T A20 010</b>

# ThermoCAN Module

## 4 Type K Thermocouple Sensors

The extended ThermoCAN module has 4 inputs for Type K thermocouple sensors. All 4 channels are galvanically isolated. The module has a 1 MBaud CAN-Interface (CAN2.0 B) for the signal input.



Mechanical Data	
Size	70,0 x 40,0 x 16,0 mm
Weight	170 g

Conditions for Use	
Operating Temperature	0 °C ... 70 °C
Temperature Range	-200 °C ... 1 000 °C
Supports NiCrNi Type K sensors	
Max. Vibration	<i>Vibration Profile 1 (see Appendix)</i>

Electrical Data	
Sampling Rate	max. 200 Hz

Power Supply	
8 V ... 18 V	
Supply Current (without load)	max. 70 mA

Communication/Configuration Interface	
Fix CAN-ID, must be changed by Bosch Motorsport if needed	

Loomside Connector	
ASL-606-05PD-HE (green)	
ASL-006-05SA-HE (yellow)	

Sensor Connector ASL-006-05SD-HE (green)	
Pin-No.	Function
1	n.c.
2	Signal minus
3	Signal positive
4	n.c.
5	screen

Comm. Connector ASL-606-05PA-HE (yellow)	
Pin-No.	Function
1	8-18V positive
2	Ground
3	CAN High
4	CAN Low
5	n.c.

Part Number	
ThermoCAN Module	<b>F 01 T A 20 028</b>

# Telemetry

## Telemetry Unit FM40

The FM40 is part of a real time telemetry system used to get measurement data from the car out on the racetrack.

It matches to the Bosch Motorsport ECUs and data logging equipment. Due to its high working range and the good data quality it is the optimum choice for the online telemetry.

In typical applications data are sent one way from the car to the pit station. With optional software for bi-directional transmission, data can be sent in both directions.



### Mechanical data

Size	151 x 138 x 28 mm
Weight	720 g
Dust and waterproof housing with LED indicators	
Car antenna compatible to existing Bosch telemetry systems	

### Conditions for use

Vibration	6 g/20 Hz ... 2 kHz
Temperature range	0 ... 60 °C
Max. power consumption	25 W at 14 V
International standard	I-ETS 300 220 ETS 300 113 FCC

### Connectors

RF	BNC female
Power / data	CGK SOT 8N35 PN

### Electrical data

Semi duplex radio modem (bidirectional)	
Internal data buffer and protocol management	
Frequency range	430 ... 470 MHz (hardware adjustable)
F(center) ±1 MHz (software programmable)	
Transmission power	1 ... 10 W
Receiver sensitivity	-116 dBm error detection and forward error correction (FEC)
RF channel bandwidth	12,5 kHz @ 9.6 kbps 25 kHz @ 19.2 kbps
Data interface	RS232
Data rate	9.6 / 19.2 kbps
Required power supply	10 ... 18 V
Max. current	< 2,5 A

### Part number

FM40	B 261 208 885
------	---------------

## Telemetry Accessories

### FM40 Tester

The FM40 Tester is a tool for checking the performance of the installed telemetry transmitter FM40 in connection with the RF-cable and the car antenna. Measured parameters are the transmission power as well as the matching of the antenna together with the RF-cables.



Measurement range	
Transmission power	1 ... 15 (60) W
VSWR	1 ... 6
Frequency band	VHF / UHF

Connectors	
RF	BNC male / female

Part number	
B 261 208 894	

### Telemetry Antenna Dummy Load

The telemetry antenna dummy load replaces the telemetry car antenna when running the FM40 transmitter in a garage in order to prevent high RF power radiation.



Measurement range	
RF power	15 W
VSWR	1.1
Frequency band	VHF / UHF

Connectors	
RF	BNC male / female

Part number	
B 261 208 890	

## Telemetry (Dual Band) Car Antenna

Rugged telemetry antennas for car mounting



Parameter	
<b>Single Band Car Antenna</b>	
Frequency band	UHF
Type	1/4λ
Pattern (hor.)	omni
Length	150 mm
<b>Dual Band Car Antenna</b>	
Frequency band	VHF / UHF
Gain	1/4λ / 5/8λ
Pattern (hor.)	omni
Length	440 mm

Connectors	
RF	BNC male

Part number	
Single Band Car Antenna	<b>B 261 208 888</b>
Dual Band Car Antenna	<b>B 261 208 862</b>

## Antenna Cable Kit For car mounting

RF cable for installation of telemetry antennas at the car. Intended for single hole mounting.



Measurement range	
Length	max. 2 m (tbd.)
Drill hole diameter	12,5 mm
Attenuation	max. 0.7 dB @ 2 m, 450 MHz

Connectors	
RF	BNC male / female

Part number	
Antenna Cable Kit	<b>B 261 209 490</b>



# Analysing

## WinDarab

### Data Recording, Analysing and Influencing

WinDarab is an evaluation tool for monitoring and analysing of logged data. It is Windows-based and specially designed for motorsport use. Depending on the functionality the software is available in two different versions, WinDarab-Light and WinDarab-Expert. For selection of monitored data channels and setting of sample rates the integrated configuration tool WinDCP is used.

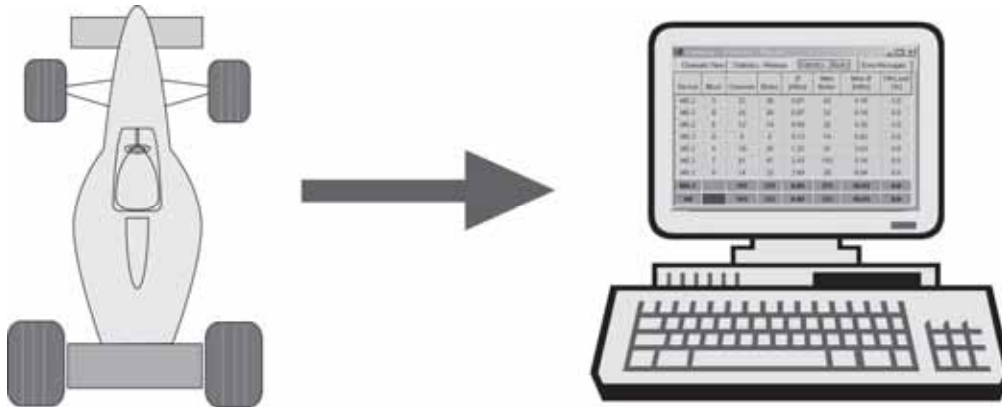

#### Data evaluation

- Auto load and auto store
- Adjustable axis: time or distance
- Direct read-in of memory data without reader
- Graphic display of all measured and stored channels
- Various displays available (analogue and digital)
- Number of displays available
- Various display set-ups selectable and storable
- Laptrigger signal included

#### Functionality

- Creating of race tracks
- Several segments adjustable for each race track
- Lap reports and lap comparison
- Inform displays
- Data extract and export

#### Functions

- Min/max-calculations
- Histograms
- Mathematical functions
- Filter functions incl. FFT
- x/y-plots

#### Data comparison

- Calculation of differences lap by lap

**WinDarab Version V6 Feature List**

Function	Light	Expert
Limited number of opened files	2	–
Limited number of measuring data windows	1	–
Limited number of areas in measuring data windows	4	–
Views - Histogram	•	•
Views - (x/y)-Plot	•	•
Views - Distribution	•	•
Views - Min/Max-Table	•	•
Views - Fourier-Transformation	•	•
Views - Outing report	–	•
Views - Lap analysis	–	•
Extras - Functions / Conditions / Differences	–	•
Extras - Settings - Comments	–	•
Measuring data window - Area channel name - View options	–	•
Desktop load / save	•	•
Reading dongle in company licence	–	–

**Part numbers**

<b>WinDarab-Light</b> incl. Configuration tool WinDCP	<b>F 01E B01 402</b>
<b>WinDarab-Expert</b> incl. Configuration tool WinDCP	<b>F 01E B01 401</b>
<b>Upgrade</b> WinDarab-Light to WinDarab-Expert	on request

# Application

## INCA-MSD

INCA is a software tool for measuring and calibrating of defined engine parameters. According to different levels of functionality INCA is available in two different versions:

- The basic version INCA-Light is made for the quick use.
- The highly sophisticated version INCA-Expert is made for calibration and optimization.

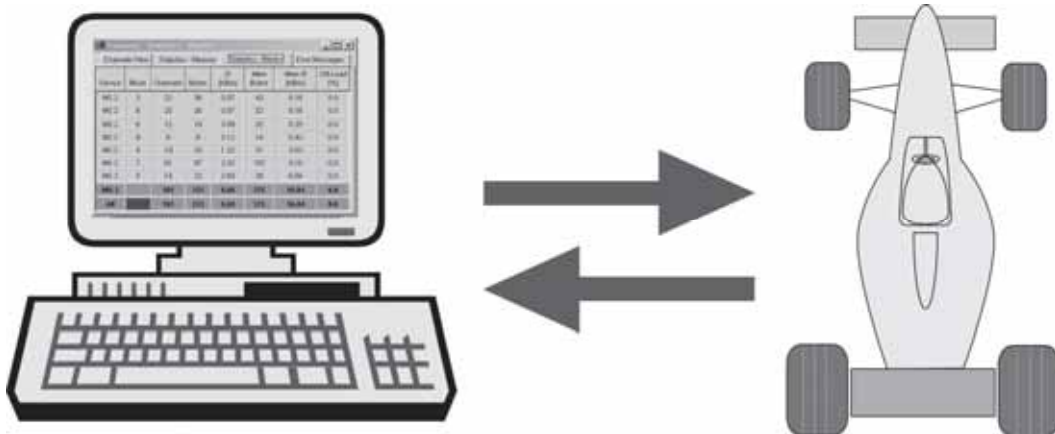

### Performance description

**INCA-MSD is a combination of:**

- **Project management:**

Visualization, processing and management of calibration, measurement and documentation data.

- **Programming system:**

Programming and management of program (code) and calibration data.

- **Measuring system:**

Acquisition, visualization, documentation and evaluation of measurement data.

- **Calibration system:**

Visualization and manipulation of parameters (calibration data).

- **Diagnosis system:**

Visualization, processing, documentation and evaluation of diagnosis data.

### General functions

Online measurement and calibration

Basic configuration of a number of views

User-configurable menus of the diagnostic services and the displays on the screen

Easy switch between the configured views

Universal use for different ECUs

Controlled by mouse or menu, fast grip via keyboard and shortcuts

Data acquisition via central main window

### Measurement system function

The measurements can be displayed in various ways: e.g. oscilloscopes, vertical or horizontal bar charts, numerical displays for numerical values or bit displays for binary values.

The oscilloscope allows you to have several scalar or binary measured signals displayed simultaneously.

Once measuring has been completed, you can complete the evaluation of the data either directly or in detail evaluation programs, such as the VS 100 program provides.

INCA processes characteristics and measured signals in the form of variables. These are structured alphabetically according to the DAMOS/ASAP 2 definition, but are also available in an additional hierarchical display.

Using an editor, you define individual functions and so react in this way to different application tasks, such as the integration of different external data sources (thermo-scan, lambda display).

Free selection of measuring cells.

### Calibration system function

INCA provides you with various editors for different characteristics, e.g. the tabular editor for processing curves and maps.

These curves and maps can be spread over several windows so that all values can be displayed at the same time.

To evaluate the data, use either the provided VSW program or copy the data to a spreadsheet program using the Windows buffer.

Free selection of calibration cells.

Functionality of potentiometer board: up to 12 pots with individually configuration.

### Evaluation function

Calibration comparison function

A lot of auxiliary functions are supporting the user during the period of working in.

### Required hardware components

#### PC:

IBM PC/AT compatible, 586 processor or higher, 166 MHz

Approx. 64 MB RAM

Approx. 30 MB harddisc space

VGA monitor

#### Operating systems:

Windows 98, 2000, NT and XP

### Part number

INCA-Expert

**B 261 206 423**

# Modas

Modas is a software tool for measuring and calibrating defined engine values and curves. It is specially designed for race track use. Developing Modas we set great store by easy handling and quick access to the ECU.

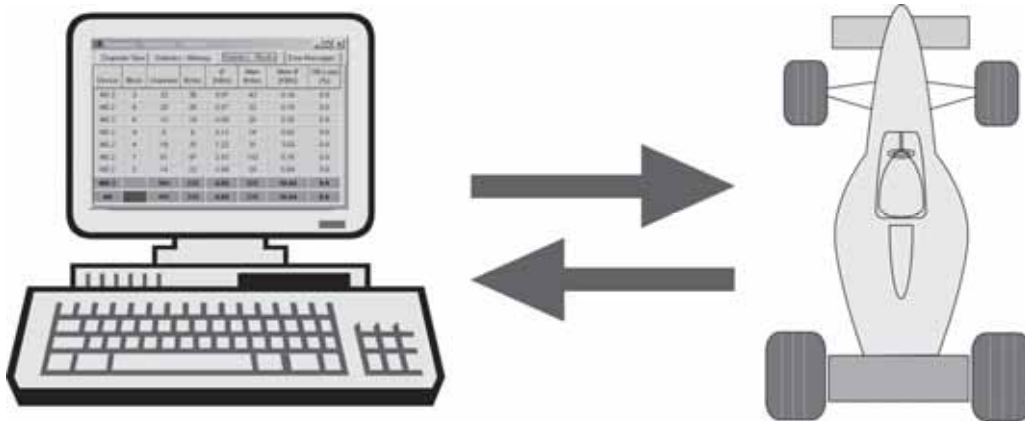

## General functions

Online measurement and calibration

Universal use for different ECUs

Modas facilitates operating and working in by using the Windows standard. In the office Modas is controlled by mouse or menu. If Modas is used in a mobile way a fast grip is possible by keyboard and shortcuts.

## Required hardware components:

### PC:

IBM PC/AT compatible, 586 processor or higher, 166 MHz

Approx. 64 Mbyte of RAM

Approx. 30 Mbyte harddisc space

VGA monitor

### Operating systems:

Windows 98, 2000, NT and XP

## Performance description

**Modas is a combination of**

- **Project (Data) management:**

Visualisation, processing and management of calibration, measurement and documentation data

- **Programming system:**

Programming and management of calibration data

- **Calibration system:**

Visualisation and manipulation of parameters (Calibration data)

- **Diagnosis system:**

Visualisation, processing, documentation and evaluation of diagnosis data

## Part number

Modas License

Free download at  
[www.bosch-motorsport.com](http://www.bosch-motorsport.com)

## KIC 2 (K-Line Interface Compact)

KIC 2 is part of the INCA module family. Within this family, the KIC 2 is the low cost unit for PC-supported application on the serial diagnosis interface of an ECU.

KIC 2 is coupled to the PC via the parallel printer interface. This ensures a powerful and universal link to all common PCs. The coupling to the ECU is effected via the K-line of the diagnosis interface. The functionality of KIC 2 is essentially determined by the operating programs of the PC.



Details	
Compact design	
Fully suitable for motor vehicle use	
Power supply through the connection to the ECU from board mains with galvanic separation	
All inputs and outputs to the PC galvanically separated	
Firmware update possible via PC	
According to ISO 9141-2 for diagnosis tester	
Up to 250 kBaud transfer rate	
Plug suitable for motor vehicles (VS 20)	
Protocols: McMess, KP 2000, Keyword 71	

Mechanical data	
Size	17 x 60 x 78 mm

Electronic data	
Input voltage	6 ... 30 V
Power consumption	typ. 1 W at 13,5 V
Power consumption in stand by	30 mW at 13,5 V
Processor	μP 87C520, 12 kByte
Flash Eprom	2 x 48 kByte
Centronics Iinterface	40 g/5Hz ... 2kHz
Temperature range	-30 ... 70°C
Control P-module output	
Output voltage	0 ... 4,096 V
Quantisation	⊗V=1,0 mV
Resolution	12 bit

Part numbers	
KIC 2, standard connector	<b>B 261 206 859</b>
KIC 2, diagnosis connector with ignition bridge	<b>B 261 206 866</b>
KIC 2, diagnosis connector without ignition bridge	<b>B 261 206 867</b>

## K-Line Extension Set

The K-Line Extension Set is an extension for KIC 2 and therefore also a part of the INCA module family. Within this family, the KIC 2 is the low cost unit for PC-supported application on the serial diagnosis interface of an ECU. The K-Line Extension Set enables a much longer distance than the KIC 2 can.

The set consists of three parts: The PC-Printer port adapter, the K-Line adapter and the extension cable (length is user defined). The user can handle the set in the same way like a standard K-Line interface.



Details	
Long distance K-Line function	
Compact design	
Fully suitable for motor vehicle use	
Power supply through the connection to the ECU from board mains with galvanic separation	
All inputs and outputs to the PC galvanically separated	
Firmware update possible via PC	
According to ISO 9141-2 for diagnosis tester	
Up to 250 kBaud transfer rate	
Plug suitable for motor vehicles (VS 20)	
Protocols: McMess, KP 2000, Keyword 71	

Mechanical data	
Size Printer Port Adapter	17 x 60 x 78 mm
Size Converter	35 x 115 x 60 mm
Size Extension Cable	10/25/50 m

Electronic data	
Input voltage	6 ... 30 V
Power consumption	typ. 1 W at 13,5 V
Power consumption in stand by	30 mW at 13,5 V
Max. extension cable length	200 m
Temperature range	-30 ... 70°C

Part numbers	
K-Line Extension Set	<b>F 01E B01 641</b>
Converter	<b>F 01T A20 041</b>
Extension Cable	<b>F01T A21 003_10/_25/_50</b>
Printer Port Adapter	<b>F 01T A20 042</b>

## MSA-Box (K-Line / CAN Interface)

The MSA-Box is the low cost unit for PC-supported application with MODAS on K-Line or CAN interface of an ECU.

The MSA-Box is coupled to the PC via the USB interface. This ensures a powerful and universal link to all common PCs. The coupling to the ECU is effected via K-Line or CAN of the diagnosis interface.



Mechanical data	
Size	84 x 33 x 20 mm
Diagnosis cable length	0,5 m
USB cable length	2 m

Conditions for use	
Temperature range	0 ... 70°C

Electronic data	
Input voltage (vehicle side)	8 ... 32 V
Power consumption (powered from USB) typ.	0,5 W
Processor	ATMEL AT91SAM7X256
Flash Eprom	256 kByte
RAM	64 kByte
USB	USB 2.0, full speed (12 Mbit/s)
K-Line	300 Bd ... up to 320 kBd
CAN	10 kBit/s ... 1 MBit/s

Operating system	
Windows 2000	
Windows XP	

Details	
Compact design	
Fully suitable for motor vehicle use	
Power supply through the connection to the ECU from board mains with galvanic separation	
All inputs and outputs to the PC galvanically separated	
According to ISO 9141-2 for diagnosis tester	
Up to 300 kBaud transfer rate (K-Line) and up to 1 MBit/s transfer rate (CAN)	
Plug suitable for motor vehicles (VS 20)	
Protocols: KWP 2000, CCP	

Part number	
MSA-Box	<b>B 261 208 015</b>



# Handheld Test Devices

## Lambda Tester

This tester simulates the output signals of the lambda sensor in a quick and comfortable way. It allows you to check the function of the lambda control loop's hardware and software just before installing it into the vehicle.



Technical data	
Power supply	9 V
Output signals	40 / 800 / 900 mV
Internal resistance	10 / 50 / 100 $\Omega$
Representable lambda values	0,65 ...1,08

Function	
High precious simulation of various lambda values	
Part number	
<b>B 261 206 879</b>	

## RS 2000

With RS 2000 you can simulate crank shaft-, cam shaft- and wheel-speed-signals quickly and comfortable.



### Functions

Infinitely variable simulation of Hall- and inductive signal

Compatible with all Bosch Motorsport-ECUs from MS 1.9 to MS 4.1

Adjustable on cylinder numbers from 4 to 12

Usable for increment- and segment-systems

### Electrical data

Power supply 12 V

### Part numbers

RS 2000 **B 261 206 862**

Cable harness connector **B 261 206 451**

# Simulation

## LapSim

**LapSim Chassis** is both an analysis tool as well as a vehicle simulation program. By further processing the on-car recorded data, using parts of the simulation models, a much more profound analysis of the vehicle behaviour can be gained. Due to the direct link with the simulation model, vehicle parameters can be validated like aerodynamics, tyre behaviour, engine power, as well as driver performance. The visualisation of the vehicle behaviour creates a much easier and better understanding of the influence of several vehicle parameters on the performance independent of the technical background of the user.

**LapSim Engine** supplies an easy to use engine simulation package capable of generating a torque/power and a corresponding ignition curves out of the main parameters of an engine. The model is able to simulate any 4-stroke spark ignition (SI) race engine currently seen on the market, with or without air restrictor(s). To summarize, the engine software is aiming for 95% accuracy but 5% the effort of complex engine software packages. The engine software avoids a vast number of variables in order to define every engine detail, in order to improve usability as well as computational performance. The engine package is integrated in the lap simulation.

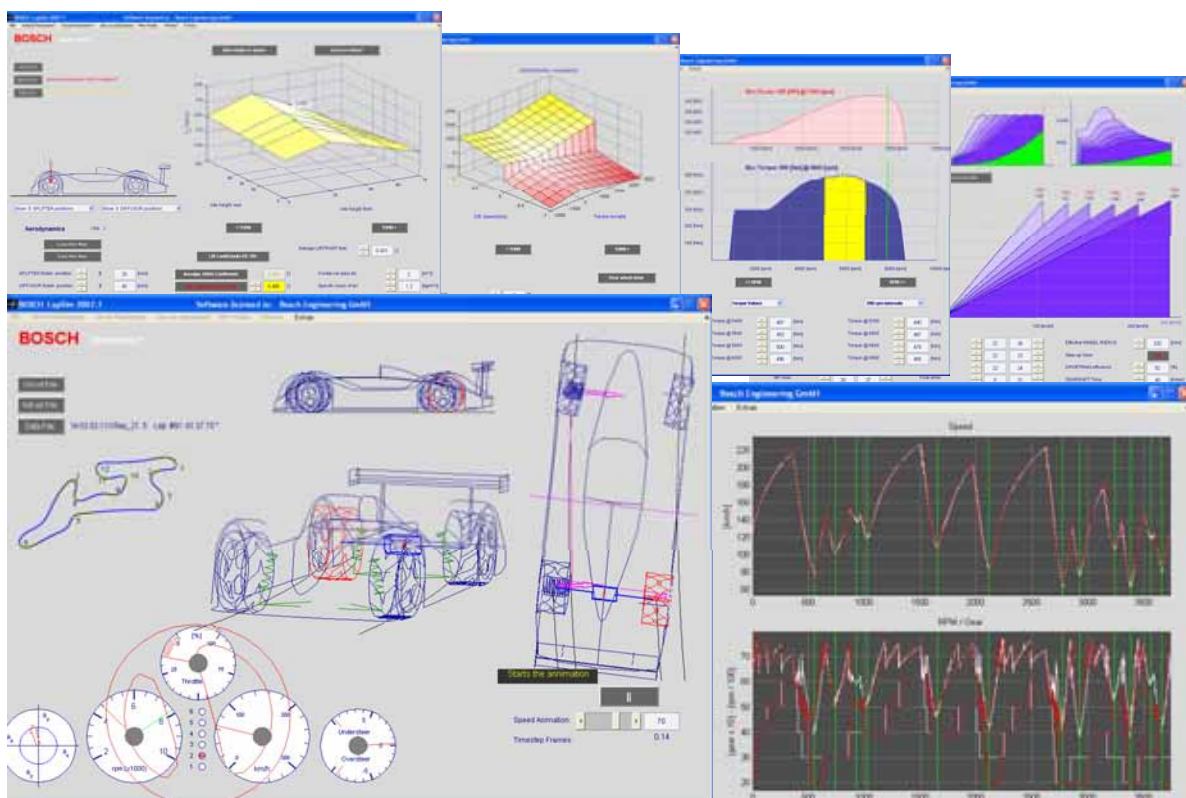

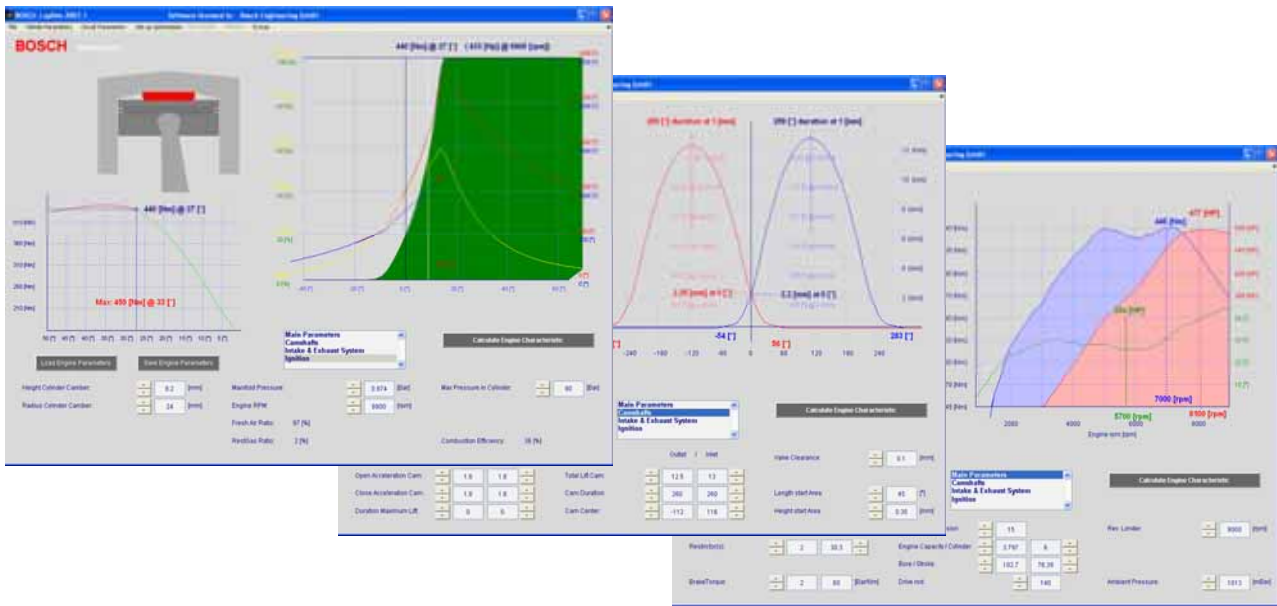

### Data analysis

Post processing of the on-car recorded data with simulation models. Calculating vehicle handling state, aerodynamics, differential function, etc.

Determination of tyre parameters out of on-car recorded data. Possibility to analyse tyre performance over the laps.

Direct comparison between several outings and/or simulation model.

3D Animation of vehicle behaviour for a better and more thorough understanding.

By comparing recorded data with simulation data a validation possibility of vehicle parameters and vehicle functioning is made.

LapSim software adds all vehicle parameters to WinDarab Files and creates automatic database.

### Chassis Simulation model

Practical Pacejka like tyre model. Tyre parameters can easily be determined out of on-car recorded data. No tyre data required.

Full vehicle model including limited slip (or visco-) differential

3D Aero maps

Ride height dependent suspension kinematics

Calculation time 3-4 times faster than real car

(PVI - 3 GHz)

Automatic set-up optimisation

### Engine Simulation model

Engine model generates torque/power curve as well as ignition angle

Normally aspirate engines, with or without restrictor

2,3,4 and 5 valve cylinder heads

2-zone burn model in order to cope with all possible compression ratios and chamber geometries

Ignition point is determined by adjustable maximum pressure in cylinder

Fully adjustable camshaft profile

Engine model generates pressure curve over 720° crankshaft, which is integrated to calculate engine torque/power

10 seconds calculation time for 0 - 10.000 rpm range

### Part numbers

LapSim Chassis Basic Version **Free download at [www.bosch-motorsport.com](http://www.bosch-motorsport.com)**

LapSim Chassis License **B 261 206 432**

LapSim Engine License **F 01T A20 056**

LapSim Engine & Chassis License **F 01T A20 057**

Upgrade LapSim Engine License **F 01T A20 058**

Upgrade LapSim Chassis License **F 01T A20 059**

# Laptrigger Systems

## Laptrigger IR-02

This laptrigger system consists of an infra-red transmitter station and a receiver installed in the car. The system allows an exact laptime measurement.

Section time measurement for comparison of different car setups is also available if several transmitters are used.

Notice: our old laptrigger IR is not compatible with IR-02. If both laptriggers are used at the same time, the transmitters have to be positioned with a minimum distance of 5 m.



Mechanical data	
<b>IR-02-Receiver</b>	
Size	42 x 20 x 10 mm
Weight	39 g
Dust and waterproof aluminium housing	
<b>IR-02-Transmitter</b>	
Size with diode	90 x 40 x 28 mm
Weight	124 g
Dust and waterproof aluminium housing	

Conditions for use	
Working range	15 m
Ambient temperature	-25 ... 70°C
Same height between receiver and transmitter	
Visibility connection between receiver and transmitter	
Avoid direct exposure to sunlight	

Electrical data	
<b>IR-02-Receiver</b>	
Frequency codes	16
Supply voltage	8 ... 16 V
Output voltage	5 V
<b>IR-02-Transmitter</b>	
Frequency codes	16 plus 16 offset codes for section times
Supply voltage	8 ... 16 V

Part numbers	
<b>IR-02-Receiver</b>	
KPSE 6E8 3AP DN A34	<b>B 261 206 884</b>
ASL-6-06-05PD-HE	<b>B 261 206 887</b>
KPTA 6E6-4P-C-DN	<b>B 261 206 888</b>
<b>IR-02-Transmitter</b>	
	<b>B 261 206 890</b>

## Laptrigger HF 24

This Laptrigger HF 24 system consists of a high frequency transmitter station and a receiver which is installed in the car.

The system allows an exact lap time measurement. Section time measurement for comparison of different car setups is also available if several transmitters are used. We offer optionally a tripod for mounting the transmitter anywhere along the race track.



Mechanical data	
<b>HF 24 Receiver</b>	
Size	125 x 37 x 28 mm
Weight	130 g
Internal antenna with radome	
Dust and waterproof aluminium housing	
<b>HF 24 Transmitter</b>	
Size	290 x 118 x 93 mm
Weight	1880 g
Dust and waterproof	
<b>Tripod</b>	
Maximum height	~ 150 cm
Minimum height	~ 65 cm
Weight	1370 g

Conditions of use	
Working range	up to 50 m
Ambient temperature	-10 ... 85 °C
Power consumption HF 24 Receiver	0,8 W
Power consumption HF 24 Transmitter	1 W

Electrical data	
<b>System</b>	
RF wideband chirp transmission	
Working frequency band	2,40 ... 2,47 GHz
User codes	16
<b>HF 24 Receiver</b>	
Sensitivity	-92 dBm @ BER 10 <sup>-3</sup> ; 1 Mbps
Supply voltage	6,5 ... 30 V
Connector type	ASL 606-05PD-HE
Pin 1	+12 V
Pin 2	GND
Pin 3	Trigger Out
Mechanical drawing	Y 261 A25 087
<b>HF 24 Transmitter</b>	
Transmission power	10 dBm
Transmitter antenna	flat panel
Supply voltage	10 ... 30 V
Supply current	90 mA
Selection main / sub trigger	
Low battery detection	
Mechanical drawing	Y 261 A25 038

Part numbers	
HF 24 Receiver	<b>B 261 206 894</b>
HF 24 Transmitter	<b>B 261 206 895</b>
Tripod	<b>B 261 206 897</b>

**Application hints**
**HF 24 Transmitter**

Before setting the main switch to ON, select the code and the working mode (main / sub trigger).

The transmitter reads the switches for code and main / sub trigger only once at power up.

After setting the main switch to ON the transmitter executes a 10 sec. self test and then the transmitter indicator begins to flash green, e.g. the transmitter is running.

The battery condition is permanently checked. If the battery level becomes critical, the "low bat indicator" becomes red. When the battery level drops below 10 V, the transmitter stops working. The green transmitter indicator stops flashing.

The transmitter should be placed at the border of the lane in a height of about 1.5 ... 2.0 m.

**HF 24 Receiver**

Before switching on the DC power the code has to be selected.

After switching ON the receiver executes a 10 sec. self test and then it turns into the working mode.

When a trigger is detected the output pin goes low for a certain time:

-20 msec low @ main trigger

-40 msec low @ sub trigger

Standard output configuration:

low side switch with  $R=3.3\text{ k}\Omega$  (\*) to +5 VDC  
 (\*) can be modified according to user demands

The white antenna radome must be turned to the transmitter side and should not be mounted behind metallic covers or carbon fiber filled elements.

Green indicator flashes when it detects a trigger condition.

**Function description**

The transmitter sends via the directional antenna coded signals across the race track.

The receiver at the race car checks permanently the team code and the signal parameters. If the trigger condition is detected the receiver generates the appropriate output signal (main/sub trigger).

The trigger point is located at broadside of the transmitter antenna.

After detecting the trigger point and releasing the trigger signal the receiver is passive for a period of two seconds avoiding a multiple trigger signal.

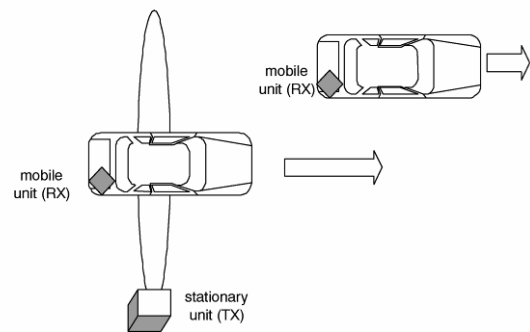

# Diesel System Components



## Diesel System Components



Injector CRI 2



HP fuel pump CP3



Rail



Pressure sensor RDS



Pressure control valve DRV

Component	Specification
Injector CRI 2	6 - 8 holes, 900 ... 1500 ccm/min at 100 bar
High pressure fuel pump CP3	Pump with control valve and optional gear pump, 0,677 ... 1,087 ccm/rev
Pressure control valve DRV	Pressure range: 100 ... 2000 bar
Pressure sensor RDS	Pressure range: 0 ... 2000 bar
Rail	Common rail for up to 6 cylinders

Further special versions and part numbers on request.

# Sensors

# Pressure Sensors Air

## Absolute Pressure Sensor PSA-B

A piezoresistive pressure sensor modified for precision air pressure measurement, especially air box pressure. It is manufactured in a DR-25 sleeve, various connector options are available.



Mechanical data	
Max. pressure	5 bar
Fitting	11,85 mm
Weight	45 g
Sealing	O-ring 7,59 x 2,62

Conditions for use	
Temperature range	-40 ... 125 °C
Max. temp. of location	130 °C
Max. vibration	120 m/s <sup>2</sup> at 10 ... 1500 Hz

Characteristic	
<b>0,1 ... 1,15 bar:</b>	
Sensitivity	4047 mV/bar
Offset	-4,3 mV
<b>0,2 ... 2,5 bar:</b>	
Sensitivity	1848 mV/bar
Offset	30 mV

Electrical data	
Power supply	4,75 ... 5,25 V
Full range output	0,4 ... 4,65 V
Compensated range	10 ... 85 °C
Accuracy of measurement	± 16 mbar
Output resistance	10 kΩ
Max. current	12,5 mA

Part numbers	
<b>0,1 ... 1,15 bar:</b>	
ASL 6-06-05PC-HE	<b>B 261 209 702</b>
<b>0,2 ... 2,5 bar:</b>	
ASL 6-06-05PC-HE	<b>B 261 209 710</b>

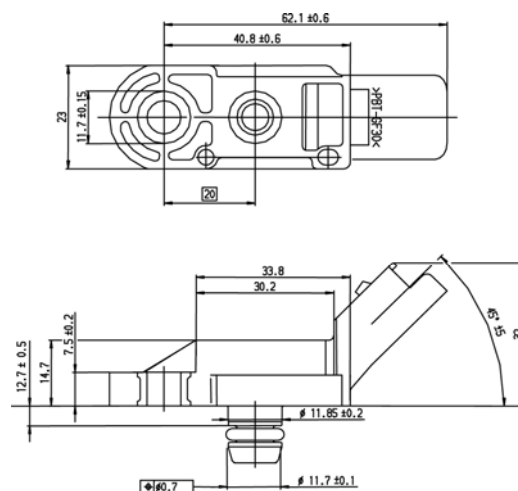

## Absolute Pressure Sensor PSA-C

A piezoresistive pressure sensor for ambient air pressure measurement.



Mechanical data	
Measurement transducer	piezoresistive
Max. pressure	5 bar
Thread	M6
Weight	40 g

Conditions for use	
Temperature range	-40 ... 125°C
Max. temp. of location	130°C
Max. vibration	15 g /30 ... 200 Hz

Characteristic	
<b>0,2 ... 1,05 bar:</b>	
Sensitivity	5000 mV/bar
Offset	-600 mV
<b>0,2 ... 2,5 bar:</b>	
Sensitivity	1532 mV/bar
Offset	724 mV

Electrical data	
Power supply	4,75 ... 5,25 V
Full scale output	0,4 ... 4,65 V
Time of reaction	10 ms (90%)
Max. current	< 12,5 mA
Resistance	> 50 kΩ

Connector	
Cable harness connector	D 261 205 289

Part numbers	
<b>0,2 ... 1,05 bar:</b>	<b>0 261 230 037</b>
<b>0,2 ... 2,5 bar:</b>	<b>0 281 002 389</b>
Offer drawing	A 261 260 143

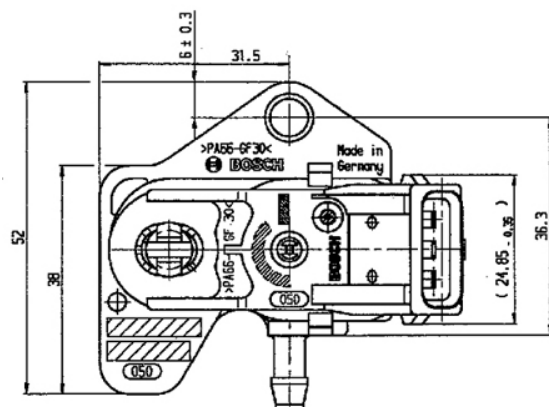
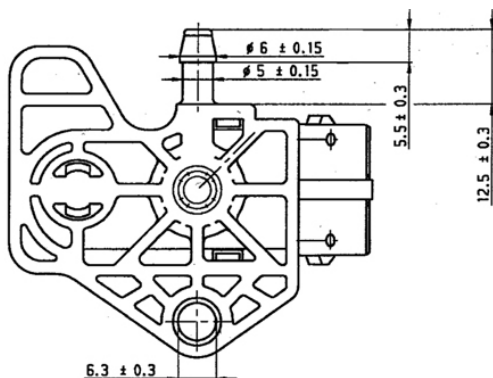

## Absolute Pressure Sensor PSB-2

An absolute pressure sensor modified for precision air pressure measurement, especially boost pressure. It is manufactured in a DR-25 sleeve, various connector options are available.



Mechanical data	
Max. pressure	3 bar
Fitting	11,85 mm
Weight	45 g
Sealing	O-ring 7,59 x 2,62

Part number	
ASL 6-06-05PC-HE	<b>B 261 209 337</b>
Offer drawing	<b>A 261 209 337</b>
ASU 6-03-05-PC-HE	<b>B 261 209 959</b>
Offer drawing	<b>A 261 209 959</b>

Conditions for use	
Temperature range	-40 ... 125°C
Max. temp. of location	130°C
Max. vibration	250 g /200 ... 500 Hz

Characteristic	
Sensitivity and offset will be delivered with each sensor.	

Electrical data	
Power supply	5 V
Compensated range	40 ... 130°C
Non linearity	0,25 %
Therm. zero point drift	< 0,5 %
Therm. sensitivity drift	< 0,5 %
Long time drift	< 0,5 %
Full scale output	0,4 ... 4,65 V
Max. current	12 mA

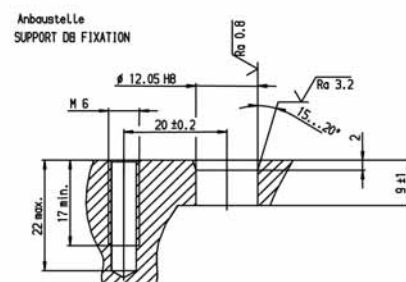
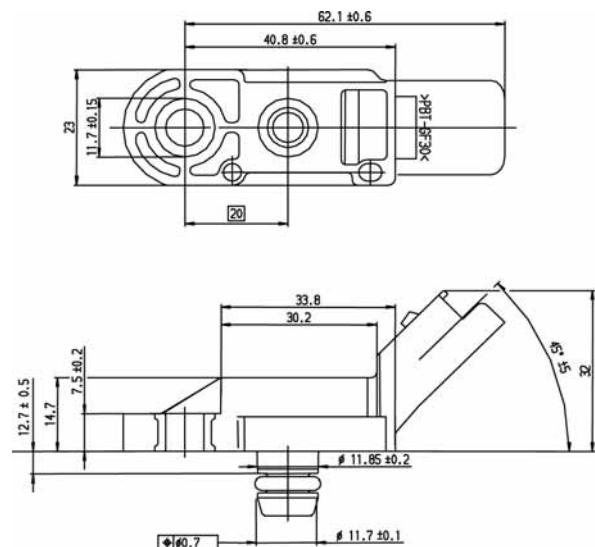

## Absolute Pressure Sensor PSB-4

An absolute pressure sensor modified for precision air pressure measurement, especially boost pressure. It is manufactured in a DR-25 sleeve, various connector options are available.



Mechanical data	
Max. pressure	4,5 bar
Fitting	11,85 mm
Weight	45 g
Sealing	O-ring 7,59 x 2,62

Conditions for use	
Temperature range	-40 ... 80°C
Max. temp. of location	80°C
Max. vibration	2 g /10 ... 1000 Hz

**Characteristic**  
Sensitivity and offset will be delivered with each sensor.

Electrical data	
Power supply	5 V
Compensated range	0 ... 80°C
Accuracy of measurement	+/- 4 mbar
Full scale output	0,5 ... 4,5 V
Max. current	12 mA

Part number	
ASL 6-06-05PC-HE	<b>B 261 209 348</b>
Offer drawing	<b>A 261 209 348</b>
ASU 6-03-05PN-HE	<b>B 261 209 954</b>
Offer drawing	<b>A 261 209 954</b>

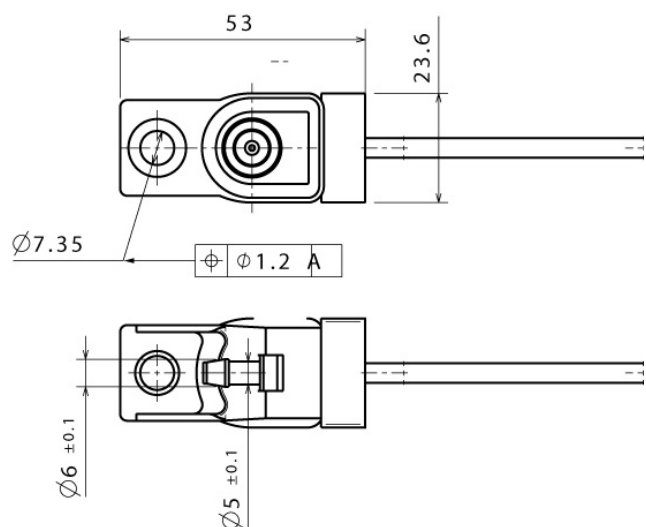
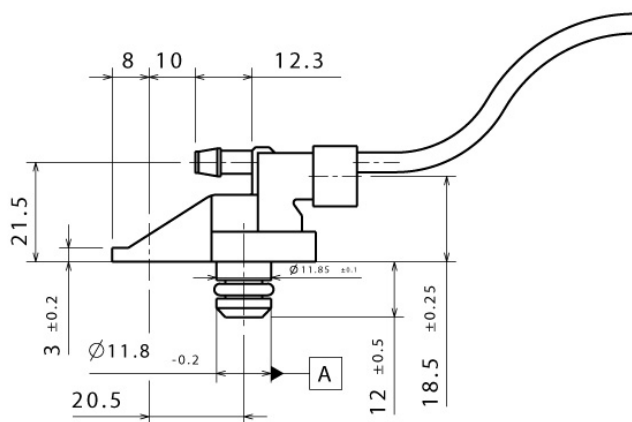

# Absolute Pressure Sensor PSP

An absolute pressure sensor modified for precision air pressure measurement.



Mechanical data	
Max. pressure	5 bar
Fitting	Ø 11,8 mm
Weight	17 g
Sealing	O-ring

Conditions for use	
Temperature range	-40 ... 125 °C
Max. vibration	25,5 g/100 ... 500 Hz
Max. temp. of location	130 °C

Characteristic	
Sensitivity	1517 mV/bar
Offset	96 mV

Electrical data	
Power supply	5 V
Compensated range	-40 ... 125°C
Non linearity	0,25 %
Therm. zero point drift	< 0,5 %
Therm. sensitivity drift	< 0,5 %
Long time drift	< 0,5 %
Full scale output	0,35 ... 4,85 V
Max. current	12 mA

Part number	
ASL 6-06-05PC-HE	<b>B 261 209 690</b>
Offer drawing	<b>A 261 260 139</b>

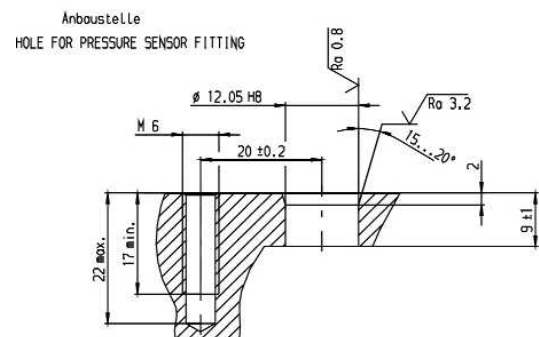
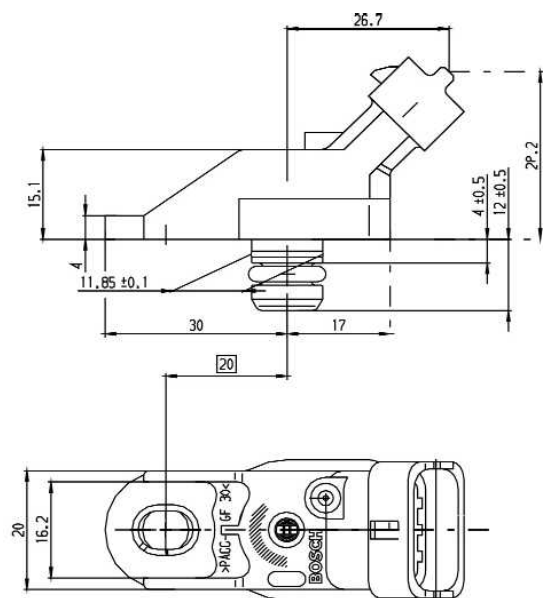

## Absolute Pressure Sensor PST

This sensor is designed to measure the absolute air pressure, especially the air box pressure of gasoline or diesel engines and the air-temperature.

A piezo-resistive sensor element and an electronic for signal amplification and temperature compensation is integrated on a silicon chip. The output of the sensor is an analogue, radiometric signal. A NTC resistant is used for the temperature measurement.

The main feature of this sensor is the integration of two sensors (air-pressure and air temperature) in one housing. A further benefit of the PST is the high quality of the production part at a low price.



Application	
Application 1	-40 ... 125 °C
Application 2	0,1 ... 1,15 bar (a)
Pressure Reference Type	absolute
Max. Pressure $p_{abs \max}$	5 bar
Operating Temp. Range	-40 ... 125 °C
Media Temp. Range	-40 ... 125 °C
Storage Temp. Range	-40 ... 130 °C
Max. Vibration	0,19 mm @ 100 - 200 Hz 25 g @ 200 - 500 Hz sine

Mechanical data	
Fixation	M6
Fitting	18 mm
Weight w/o Cable	30 g
Sealing	O-ring 13,95 x 2,62 mm

Electrical data	
Power Supply $U_s$	4,5 ... 5,5 V
Max Power Supply $U_s \max$	16 V
Full Scale Output $U_A @ 5V$	0,3 ... 4,8 V
Current $I_s$	9 mA



**Characteristic Application 1**

T [°C]	R [Ohm]
-40	45.313
-30	26.114
-20	15.462
-10	9.397
0	5.896
10	3.792
20	2.500
25	2.057
30	1.707
40	1.175
50	834
60	596
70	436
80	323
90	243
100	187
110	144
120	113
130	89

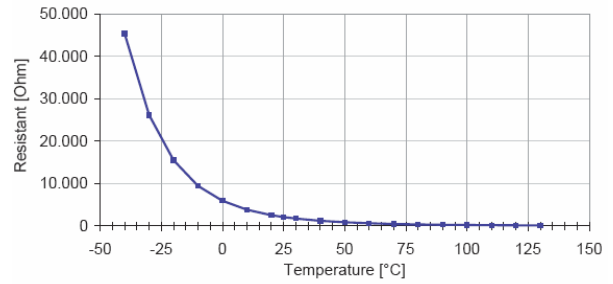

Resistant @ 20 °C	2,5 kOhm
Tolerance	5 %
Response Time Tau63	45 s @ air ; v = 6 m/s

**Characteristic Application 2**

Response Time T10/90	0,2 ms
Compensated Range	10 ... 85 °C
Tolerance (FS) @ US = 5V +/-	0,016 bar
Tolerance (FS) +/-	1,39 %
Sensitivity	4.047 mV/bar
Offset	-4,76 mV

**Connectors and Cable**

Connector	Bosch Compact
Connector Loom	D 261 230 336
Pin 1	ground
Pin 2	signal NTC
Pin 3	Us
Pin 4	signal

Various military and automotive connectors on request.

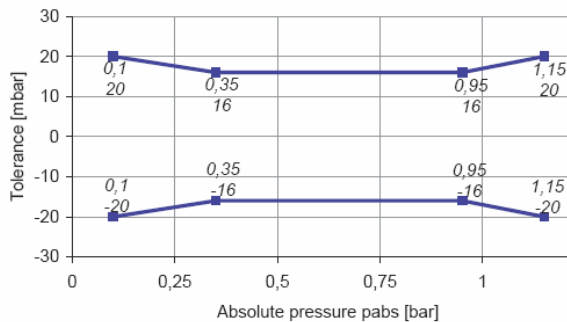
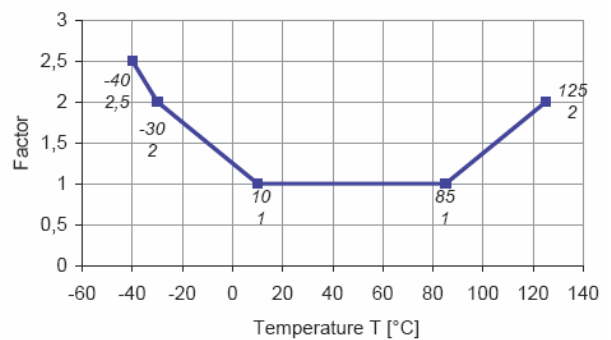
**Tolerance**

**Expansion of Tolerance f(T)**

### Application Hints

The PST is designed for engines using ROZ95, ROZ98, M15, E22, Diesel.

The sensor can be connected directly to most control units.

To avoid overtones, an ECU-input circuit with a RC-lowpass filter ( $\tau = 2\text{ms}$ ) is recommended.

For the temperature measurement, a 1 kOhm pull-up at 5V is recommended.

Use engine oil (5W40) as O-Ring grease (no silicone based grease).

Avoid miss-pinning (max 5 minutes @  $I = 0,3\text{ A}$ ).

Please find further application hints in the offering drawing (<http://www.bosch-motorsport.com>).

### Part Number

PST 0 261 230 022

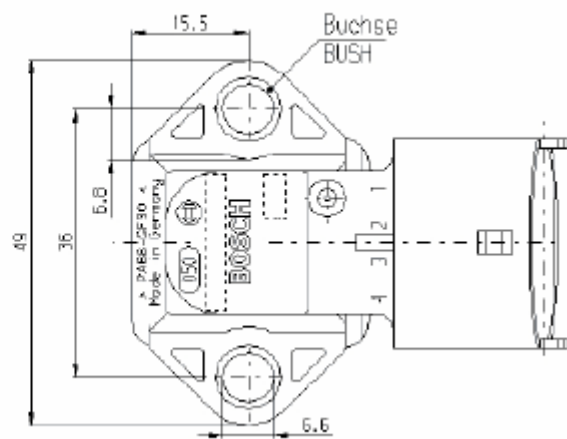
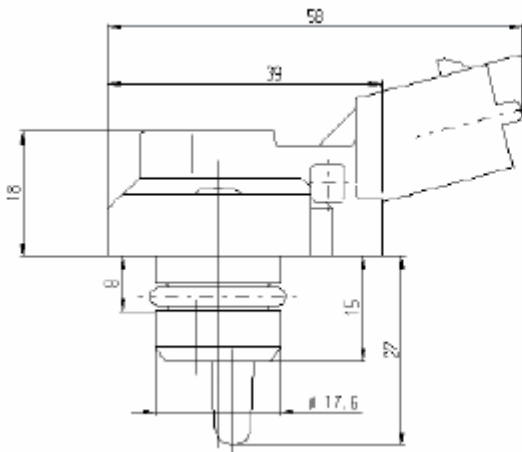

# Pressure Sensors Fluid

## Absolute Pressure Sensor PSC-10

This sensor is designed to measure the absolute pressure of various kind of applications (e.g. Diesel, gasoline, water, engine oil, transmission oil, air). Different supply voltages are available.

In our sensors we are using mainly stainless steel measuring cells with piezo-resistive measuring bridges in thin layer technique, which are hermetically welded together with stainless steel pressure ports. In this way complete media compatibility is guaranteed.

The main feature and benefit of this sensor is the combination of both high quality production part and military spec connection.



Application	
Application	0,5 ... 11 bar (a)
Pressure Reference Type	absolute
Max. Pressure $p_{abs \max}$	20 bar
Operating Temp. Range	-40 ... 125 °C (140 °C)
Media Temp. Range	-40 ... 125 °C (140 °C)
Storage Temp. Range	-20 ... 50 °C
Max. Vibration	10 g eff/rms @ 10 ... 2000 Hz

Electrical data	
Power Supply $U_s$	[1] 4,75 ... 5,25 V [2] 8 ... 30 V
Max Power Supply $U_s \max$	+/- 30 V
Full Scale Output $U_A$	[1] 10 ... 90 % $U_s$ -ratiometric [2] 0,5 ... 4,5 V non-ratiometric
Current $I_s$	8 mA

Mechanical data	
Male Thread	M10x1 mm
Wrench Size	17 mm
Installation torque	15 Nm
Weight w/o Cable	45 g
Sealing	O-ring 7,65 x 1,63 mm

Characteristic	
Response Time $T_{10/90}$	[1] 1,5 ms [2] 1,0 ms
Compensated Range	0 ... 90 °C
Tolerance (FS) @ $U_s = 5V$	0,1 bar
Tolerance (FS)	+/- 1 %
Sensitivity	[1] @ $U_s = 5V$ : 400 mV/bar [2] 400 mV/bar
Offset	[1] @ $U_s = 5V$ : 100 mV [2] 100 mV

### Connectors and Cables

Connector	KPTC 6E8-4P-C-DN
Connector Loom	KPTC 6E8-4P-C-DN
Pin 1	[2] U <sub>s</sub>
Pin 2	ground
Pin 3	signal
Pin 4	[1] U <sub>s</sub>
Various military and automotive connectors on request.	
Sleeve	DR-25
Cable Size	AWG 24
Cable Length L	13 ... 95 cm
Please specify the requested cable length with your order.	

### Application Hint

The PSC can be connected directly to most control units.

The sensor has a protection for over voltage, reverse polarity and short-circuit.

Each mounting orientation is possible.

The sensor meets all EMV, EMC and ESD automotive standards.

Please find further application hints in the offering drawing (<http://www.bosch-motorsport.com>).

### Part numbers

PSC-10 [1]	<b>F 01T A21 304</b>
PSC-10 [2]	<b>B 261 209 079</b>

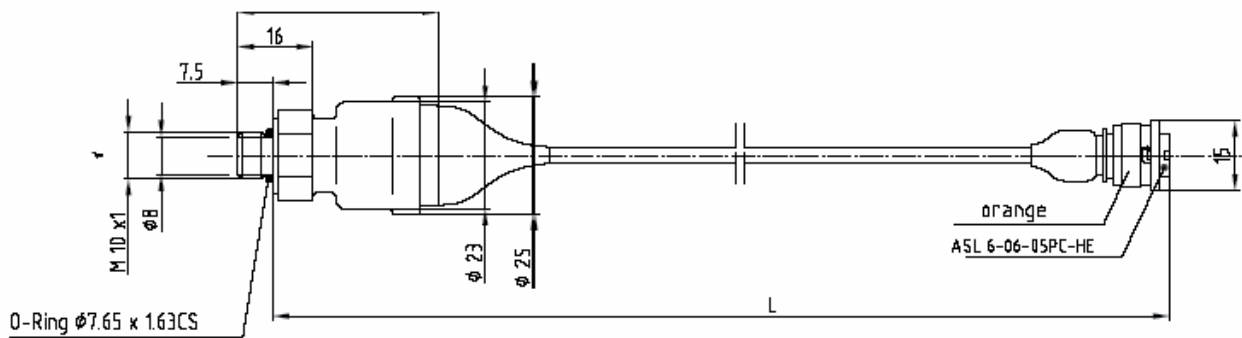

## Absolute Pressure Sensor PSC-250

A M10 x 1 sensor for various fluid pressure measurement. The sensor range covers pressure measurement from 0 to 250 bar. It is manufactured in a DR-25 sleeve, various connector options are available. Gauge and absolute pressure sensors are available.



Mechanical data	
Measurement transducer	piezoresistive
Max. pressure	500 bar
Thread	M10 x 1
Tightening torque	10 Nm
Wrench size	17 mm
Weight	70 g
Sealing	O-ring 7,65 x 1,63

Conditions for use	
Temperature range	-40 ... 125 °C
Max. vibration	15 g/30 ... 200 Hz

Characteristic	
Sensitivity	16 mV/bar
Offset	500 mV

Electrical data	
Power supply	8 ... 16 V
Compensated range	25 ... 85 °C
Current supply	8 ... 16 mA
Non linearity	1 %
Therm. zero point drift	< 1 %
Therm. sensitivity drift	< 1 %
Long time drift	< 1 %
Full scale output	0,5 ... 4,5 V
Time of reaction	1 ms (90 %)

Part numbers	
KPTC 6E8-4P-C-DN	<b>B 261 209 066</b>
KPTA 6E6-4P-C-DN	<b>B 261 209 076</b>
AS 6-08-98PN	<b>B 261 209 078</b>

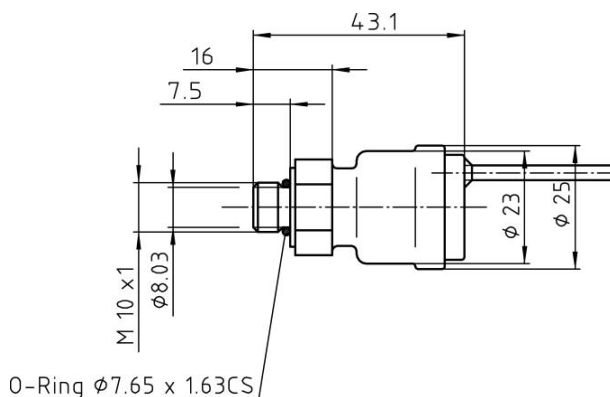

# Absolute Pressure Sensor PSM

A miniature M10 x 1 absolute pressure sensor for universal precision pressure measurement. It is manufactured in a DR-25 sleeve, various connector options are available. Detailed calibration sheet included.



Mechanical data	
Max. pressure	2 x nominal
Thread	M10 x 1
Tightening torque	10 Nm
Wrench size	16 mm
Weight	55 g
Sealing	O-ring 7,65 x 1,63

Conditions for use	
Temperature range	-20 ... 125°C
Vibration	80 g/5 Hz ... 2,5 kHz

Characteristic	
Sensitivity and offset will be delivered with each sensor.	

Electrical data	
Power supply	8 ... 16 V
Compensated range	20 ... 80°C
Non linearity	0,25 %
Therm. zero point drift	< 0,5 %
Therm. sensitivity drift	< 0,5 %
Long time drift	< 0,5 %
Full scale output	0 ... 5 V

Part numbers	
ASL 6-06-05PC-HE	
2 bar	<b>B 261 209 335</b>
Offer drawing	<b>A 261 209 330</b>
12 bar	<b>B 261 209 331</b>
Offer drawing	<b>A 261 209 331</b>
250 bar	<b>B 261 209 332</b>
Offer drawing	<b>A 261 209 332</b>

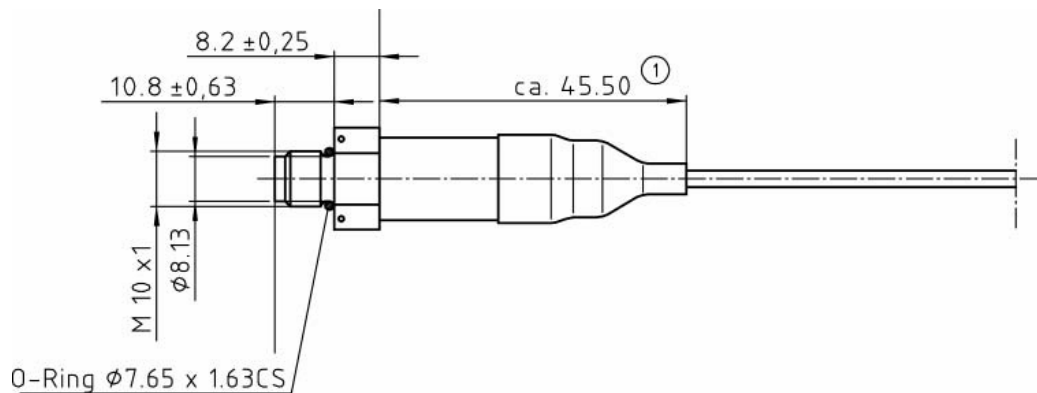

## Absolute Pressure Sensor PSS

A M10 x 1 pressure sensor for measuring various fluid pressure. Gauge and absolute pressure sensors are available.



Mechanical data	
Measurement transducer	piezo-resistive
Max. pressure	2 x nominal
Thread	M10 x 1
Tightening torque	10 Nm
Wrench size	17 mm
Weight	65 g
Sealing	O-ring 7,65 x 1,63

Conditions for use	
Temperature range	-40 ... 125 °C
Vibration	15 g/30 ... 200 Hz

Characteristic	
<b>Sensitivity</b>	
10 bar	400 mV/bar
100 bar	40 mV/bar
250bar	16 mV/bar
<b>Offset</b>	
10 bar	100 mV
100 bar	500 mV
250 bar	500 mV

Electrical data	
Power supply	5 ... 6 V/ 8 ... 16 V
Compensated range	20 ... 85°C
Current supply	8 ... 16 mA
Non linearity	1 %
Therm. zero point drift	< 1 %
Therm. sensitivity drift	< 1 %
Long time drift	< 1 %
Full scale output	0,5 ... 4,5 V
Time of reaction	1 ms (90 %)

Part numbers	
5 ... 6 V supply, 10 bar	<b>B 261 209 341</b>
8 ... 16 V supply, 10 bar	<b>B 261 209 064</b>
5 ... 6 V supply, 100 bar	<b>B 261 209 347</b>
8 ... 16 V supply, 250 bar	<b>B 261 209 067</b>

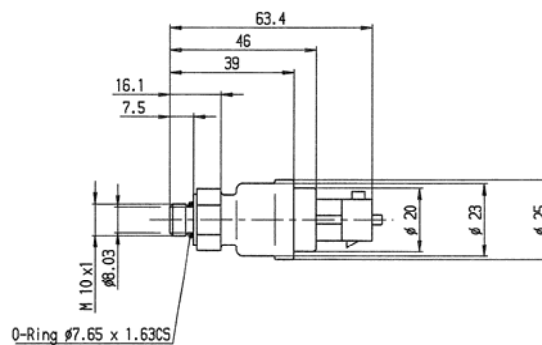

# Pressure Sensors Differential

## Differential Pressure Sensor DP-A

This miniature differential pressure sensor is used for precision air pressure measurement. It is typically combined with a pitot tube.



Mechanical data	
Dimensions	37 x 28 x 19 mm
Fixing	2 x M3
Tightening torque	2 Nm
Weight	28 g

Conditions for use	
Temperature range	-20 ... 70°C

Characteristic	
Sensitivity	40 mV/mbar
Offset	500 mV

Electrical data	
Power supply	4,8 ... 15 V
Output current	10 mA
Compensated range	0 ... 50°C
Non linearity	0,5 %/FSO
Therm. zero point drift	0,05 %/FSO/°C
Therm. sensitivity drift	0,05 %/FSO/°C
Long time drift	± 0,20 %/FSO
Full scale output	0,5 ... 4,5 V

Accessories	
Pitot tube	<b>B 261 209 700</b>

Part numbers	
ASL 0-06-05PC-HE	<b>B 261 209 696</b>
Offer drawing	<b>A 261 209 696</b>

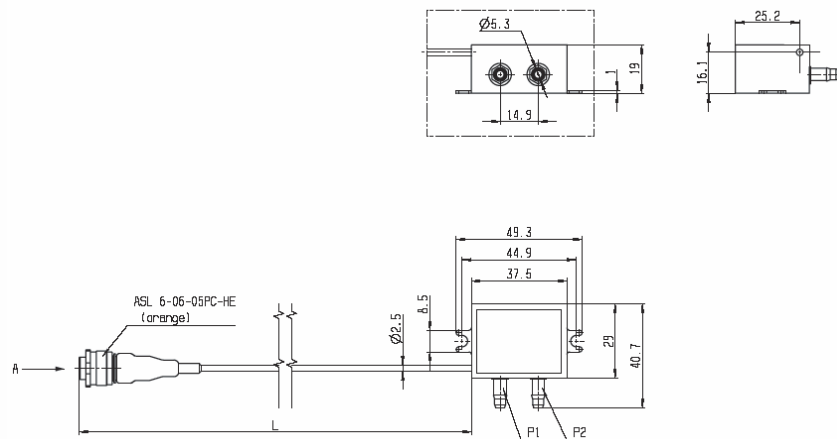



## Differential Pressure Sensor DP-B

This miniature differential pressure sensor is used for precision air pressure measurement. It is typically combined with a pitot tube.



Mechanical data	
Dimensions	38 x 28 x 19 mm
Fixing	2 x M3
Tightening torque	2 Nm
Weight	28 g

Conditions for use	
Temperature range	-20 ... 70°C

Characteristic	
Sensitivity	40 mV/mbar
Offset	500 mV

Electrical data	
Power supply	4,8 ... 15 V
Output current	10 mA
Compensated range	0 ... 50°C
Non linearity	0,5 %/FSO
Therm. zero point drift	0,05 %/FSO/°C
Therm. sensitivity drift	0,05 %/FSO/°C
Long time drift	± 0,20 %/FSO
Full scale output	0,5 ... 4,5 V

Accessories	
Pitot tube	<b>B 261 209 700</b>

Part numbers	
AS 0-06-05PC-HE	<b>B 261 209 697</b>
Offer drawing	<b>A 261 209 697</b>

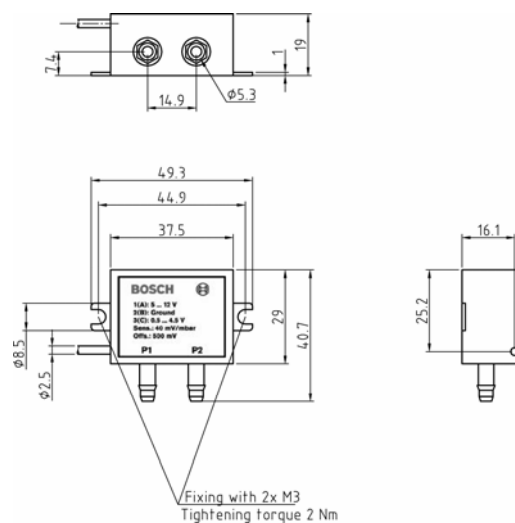

## Differential Pressure Sensor DP-C

This sensor is designed to measure the relative pressure of various kinds of applications (e.g. non-corrosive, non-ionic working fluids, such as dry air and dry gases).

The sensor supplies two pressure connections (horizontal / vertical). This enables you to use this as a differential pressure measuring device. A typically application is the measuring of the vehicle speed by using a pitot tube.

The main feature and benefit of this sensor is the combination of high quality, small size, and military spec connection. The sensor provides a very fine resolution at small pressure ranges.



Application	
Application	0 ... 0,1 bar (r)
Pressure Reference Type	relative
Max. Pressure p <sub>absmax</sub>	1,4 bar
Operating Temperature Range	-20 ... 70 °C
Media Temperature Range	-20 ... 70 °C
Storage Temperature Range	-40 ... 85 °C
Max. Vibration	20 g, 10-500 Hz

Electrical data	
Power supply U <sub>s</sub>	4,8 ... 15 V
Max Power Supply U <sub>Smax</sub>	15 V
Full Scale Output U <sub>A</sub>	0,5 ... 4,5 V
Current I <sub>s</sub>	12 mA

Mechanical data	
Fixing	2 x M2,5
Fitting	2,6 mm
Installation Torque	2 Nm
Weight w/o Cable	24 g
Size (w*I*h)	35 x 25(40) x 18 mm
Pressure Port	5 mm

Characteristic	
Response Time T <sub>10/90</sub>	0,1 ms
Compensated Range	0 ... 50 °C
Thermal Effects @ 0 ... 50 °C rel to 25 °C	0,1 % FS/°C
Non-Linearity and Hysteresis	0,1 % FS
Long Term Stability (1 Mio cyl or 1 Year)	+/- 0,2 % FS
Sensitivity	40 mV/mbar
Offset	500 mV

**Connectors and Cables**

Connector	ASL 6-06-05PC-HE
Connector Loom	ASL 0-06-05SC-HE
Pin 1	Us
Pin 2	Gnd
Pin 3	Sig
Sleeve	DR-25
Cable Size	AWG 24
Cable Length L	15 ... 100 cm

**Application Hint**

Media: Non-corrosive, non-ionic working fluids, such as dry air and dry gases.

The DP-C can be connected directly to most control units.

Any mounting orientation is possible.

Make sure that the range of supplied pressure ( $P2 \geq P1$ ).

Please find further application hints in the offer drawing (<http://www.bosch-motorsport.com>).

**Accessories**

Pitot static tube PT **B 261 209 700**

**Part number**

ASL 0-06-05PC-HE **B 261 209 701**

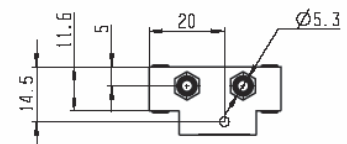
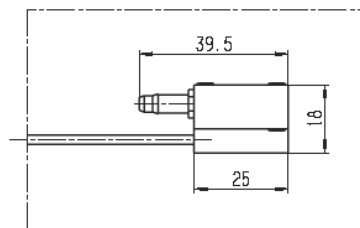

Auxiliary view A  
Scale: 1:1

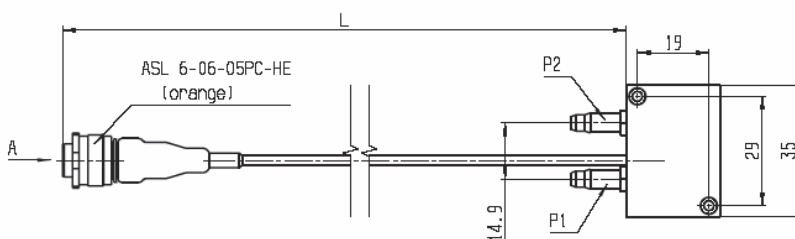

# Pitot Static Tube PT

The pitot static tube consists basically of two concentric tubes, with the end turned through a right angle so that the tip can be faced into the air stream after insertion through the duct wall. The modified ellipsoidal nose form has a single forward facing hole for sensing total pressure and a ring of side holes for sensing the static pressure. Both these inlets are individually connected to tapping outlets at the tail of the unit. A direction pointer is provided so that the pitot tube can be accurately aligned within the duct.



Mechanical data	
Weight	50 g
Height	150 mm
Tube diameter	4 mm

Part number	
<b>Pitot Static Tube PT</b>	<b>B 261 209 700</b>
Offer drawing	A 261 209 700

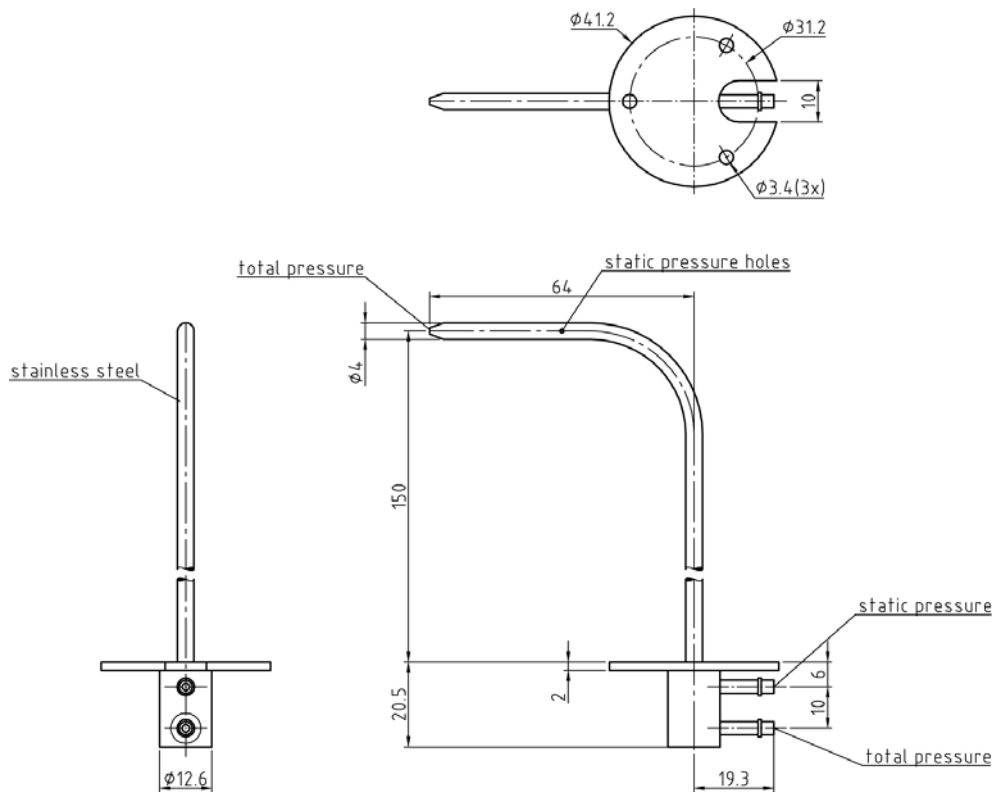

$$\text{total pressure} = \text{static pressure} + \text{velocity pressure}$$

### Air Velocity Calculations using S.I. Scales

The Standard formula for calculating velocity from velocity pressure is:

$$V = 1.291 \sqrt{P_v}$$

This is only correct for an air density of 1.2 kg/m<sup>3</sup>. For non-standard air conditions, this equation becomes:

$$V = 1.291 \sqrt{\frac{1013.25}{B} * \frac{T}{293} * \frac{100000}{100000 + P_s} * P_v}$$

$V$  = velocity m/s

$B$  = barometric pressure mbar

$T$  = absolute temperature K (=  $t^{\circ}\text{C} + 273$  where  $t$  is airstream temperature)

$P_s$  = static pressure Pa

$P_v$  = velocity pressure Pa

The expression  $\frac{100000}{100000 + P_s}$  is a correction for the static pressure in the duct and may normally be ignored if  $P_s$  is less than 2500 Pa

### Principle of Operation

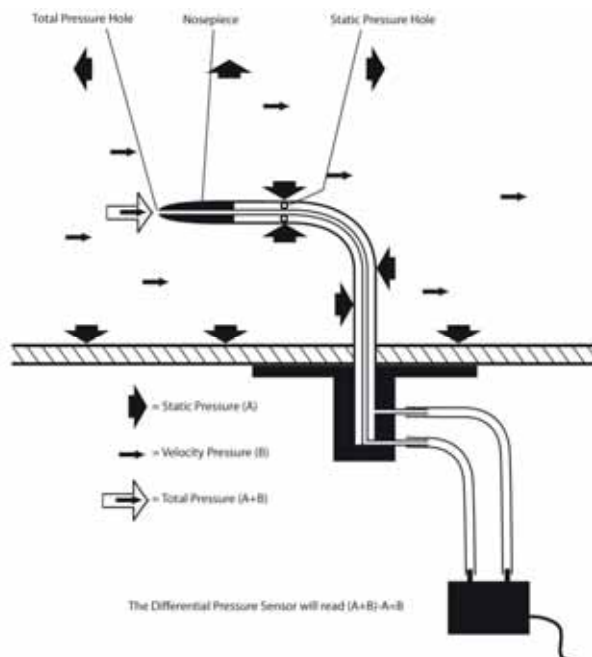

# Temperature Sensors

## Temperature Sensor TI-16

This infrared temperature sensor is designed for a non contact surface temperature measurement of various parts (e.g. tires, brake discs, and cylinder heads) based on IR radiation.

Using ruggedized silicon-coated optics, internal electronics and cabling packaged inside a stainless steel housing, this sensor measures the emitted infrared radiation of an object and calculates its temperature. The output signal has a linear characteristic (temperature vs. output voltage).

The main features of this sensor are its compact size, robust design, and high signal quality at a low cost. In addition, it offers the ability to change the temperature range, the output voltage and emissivity by request.



Application	
Application	0 ... 160 °C
Operating Temp. Range (sensing head)	-20 ... 120 °C
Operating Temp. Range (electronics)	-20 ... 70 °C
Storage Temperature Range	-40 ... 85 °C
Relative Humidity	10 ... 95 %
Max. Vibration any axis	3 m/s <sup>2</sup> @ 11 ... 200 Hz 50 m/s <sup>2</sup> , 11 ms shock

Mechanical data	
Male Thread	M12x1 mm
Wrench Size	14 mm
Length Housing	28 mm
Weight with Cable 1 m	42 g

Electrical data	
Power Supply $U_s$	5 ... 28 V
Max Power Supply $U_{smax}$	28 V
Full Scale Output $U_A$	0 ... 5 V
Current $I_s$	9 mA

Characteristic	
Emissivity (pre defined)	[1] 0,95 (rubber) [2] 0,80 (steel)
Optical Resolution	10 : 1
Spectral Range	8 ... 14 $\mu\text{m}$
Compensated Range	-20 ... 120 $^{\circ}\text{C}$
Temperature resolution @ $T_{\text{obj}} < 100\text{ }^{\circ}\text{C}$	0,1 $^{\circ}\text{C}$
System Accuracy @ 23 $^{\circ}\text{C}$ $t_{\text{amb}}$ , or max value	+/- 1,5 $^{\circ}\text{C}$ or 1,5 %
Repeatability @ 23 $^{\circ}\text{C}$ $t_{\text{amb}}$ , or max value	+/- 0,75 $^{\circ}\text{C}$ or 0,75 %
Sensitivity	31,25 mV/ $^{\circ}\text{C}$
Offset	0 mV

Connectors and Cables	
Connector	ASL 6-06-05PN-HE
Connector Loom	ASL 0-06-05SN-HE
Pin 1	Us
Pin 2	ground
Pin 3	signal
Pin 4	Prg
Pin 5	Scr
Various military and automotive connectors on request.	
Sleeve	Viton
Cable Size	AWG 26
Cable Length L	70 ... 100 cm
Please specify the requested cable length with your order.	

Application Hint
The TI-16 can be connected directly to most control units and data logging systems.
The temperature measurement range can be changed anywhere in the range of -20 $^{\circ}\text{C}$ to 1000 $^{\circ}\text{C}$ per request.
The emissivity can be changed by request.
The predefined emissivity can differ from the real emissivity.
To determine the emissivity, please contact Bosch Motorsport for assistance.
The sensor is protected against reverse polarity and short-circuit.
Sensor can be mounted in any orientation.
Do not disconnect the electronics housing from the sensor.
The sensor meets the EMV qualification 89/336/EWG.
Please avoid abrupt temperature changes.
For mounting please use only the integrated thread.
Please ensure that the environmental conditions do not exceed the sensor specifications.
To clean the lens use only a soft, wet (water or water based glass cleaner) cloth -> NO DISSOLVER cleaner!
Please find further application hints in the offer drawing ( <a href="http://www.bosch-motorsport.com">http://www.bosch-motorsport.com</a> ).

Part numbers	
TI-16-r [1]	F 01T A21 207
TI-16-s [2]	F 01T A21 209

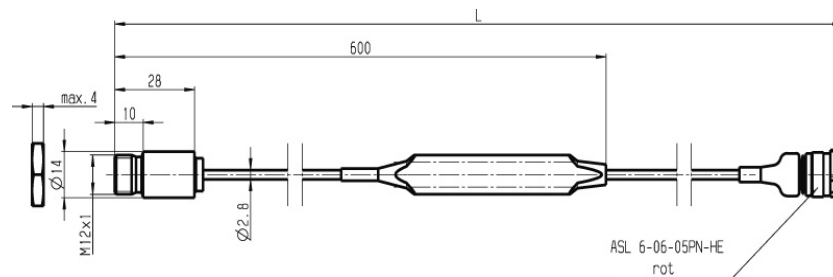

## Temperature Sensor TI-100

This infrared temperature sensor is designed for a non contact surface temperature measurement of various parts (e.g. tires, brake discs, and cylinder heads) based on IR radiation.

Using ruggedized silicon-coated optics, internal electronics and cabling packaged inside a stainless steel housing, this sensor measures the emitted infrared radiation of an object and calculates its temperature. The output signal has a linear characteristic (temperature vs. output voltage).

The main features of this sensor are its compact size, robust design, and high signal quality at a low cost. In addition, it offers the ability to change the temperature range, the output voltage and emissivity by request.



Application	
Application	0 ... 1000 °C
Operating Temp. Range (sensing head)	-20 ... 120 °C
Operating Temp. Range	-20 ... 70 °C (electronics)
Storage Temperature Range	-40 ... 85 °C
Relative Humidity	10 ... 95 %
Max. Vibration any axis	3 m/s <sup>2</sup> @ 11 ... 200 Hz 50 m/s <sup>2</sup> , 11 ms shock

Mechanical data	
Male Thread	M12x1 mm
Wrench Size	14 mm
Length Housing	28 mm
Weight with Cable 1 m	42 g



Characteristic	
Emissivity (pre defined)	[1] 0,80 (steel) [2] 0,75 (carbon)
Optical Resolution	10 : 1
Spectral Range	8 ... 14 $\mu\text{m}$
Compensated Range	-20 ... 120 $^{\circ}\text{C}$
Temperature resolution @ $T_{\text{obj}} < 100^{\circ}\text{C}$	0,1 $^{\circ}\text{C}$
System Accuracy @ 23 $^{\circ}\text{C}$ $t_{\text{amb}}$ , or max value	+/- 1,5 $^{\circ}\text{C}$ or 1,5 %
Repeatability @ 23 $^{\circ}\text{C}$ $t_{\text{amb}}$ , or max value	+/- 0,75 $^{\circ}\text{C}$ or 0,75 %
Sensitivity	5 mV/ $^{\circ}\text{C}$
Offset	0 mV

Connectors and Cables	
Connector	ASL 6-06-05PN-HE
Connector Loom	ASL 0-06-05SN-HE
Pin 1	Us
Pin 2	ground
Pin 3	signal
Pin 4	Prg
Pin 5	Scr
Various military and automotive connectors on request.	
Sleeve	Viton
Cable Size	AWG 26
Cable Length L	70 ... 100 cm
Please specify the requested cable length with your order.	

Electrical data	
Power Supply $U_s$	5 ... 28 V
Max Power Supply $U_{s\text{max}}$	28 V
Full Scale Output $U_A$	0 ... 5 V
Current $I_s$	9 mA

Application Hint
The TI-100 can be connected directly to most control units and data logging systems.
The temperature measurement range can be changed anywhere in the range of -20 $^{\circ}\text{C}$ to 1.000 $^{\circ}\text{C}$ per request.
The emissivity can be changed by request.
The predefined emissivity can differ from the real emissivity.
To determine the emissivity, please contact Bosch Motorsport for assistance.
The sensor is protected against reverse polarity and short-circuit.
Sensor can be mounted in any orientation.
Do not disconnect the electronics housing from the sensor.
The sensor meets the EMV qualification 89/336/EWG.
Please avoid abrupt temperature changes.
For mounting please use only the integrated thread.
Please ensure that the environmental conditions do not exceed the sensor specifications.
To clean the lens use only a soft, wet (water or water based glass cleaner) cloth -> NO DISSOLVER cleaner!
Please find further application hints in the offer drawing ( <a href="http://www.bosch-motorsport.com">http://www.bosch-motorsport.com</a> ).

Part numbers	
TI-100 s (steel) [1]	F 01T A21 210
TI-100 c (carbon) [2]	F 01T A21 211

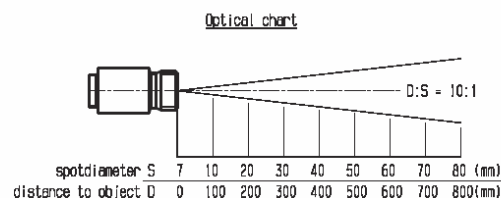
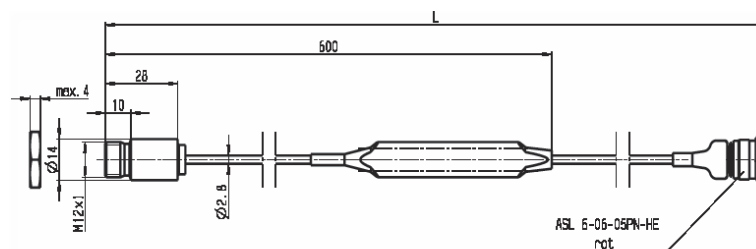

## Temperature Sensor NTC M6

This sensor is designed to measure the fluid temperatures of oil, water, fuel e.g.. For example, this signal is used as a control value for engine control units or as a measurement value which is logged in a data acquisition system.

The NTC-resistance has a negative temperature coefficient; this means, that with increasing temperature the conductivity rises and the resistance decreases. The NTC-sensor is a lacquer-coated thermistor disk which is connected via a copper-clad Fe wire to a AWG24 cable. To achieve a perfect temperature measurement, the thermistor is molded into a high performance heat paste.

The main benefit of the sensor is the combination of both high quality production part and a robust, compact design.



Application	
Application	-55 ... 125 °C
Storage Temperature Range	0 ... 100 °C
Max. Vibration	80g, 5-500 Hz

Electrical data	
Characteristic	NTC
Max Power at 25 °C	200 mW
Nominal Resistance	15 kOhm @ 25°C

Mechanical data	
Male Thread	M6 x 1
Wrench size	10 mm
Installation Torque	3 Nm
Weight w/o Cable	8,5 g
Sealing	4,47 x 1,78 mm

**Characteristic**

Accuracy @ 25°C	+/- 1,1 °C
Accuracy @ 100°C	+/- 4,4 °C
Relative Resistance Tolerance @ 25 °C	+5%
Response Time tau_63 in still water	< 9 s

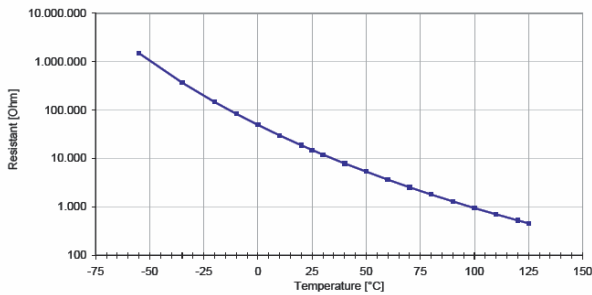

T [°C]	R [Ohm]
-55	1.493.300
-35	366.720
-20	145.880
-10	83.317
0	49.254
10	29.959
20	18.732
25	15.000
30	12.012
40	7.894
50	5.356
60	3.651
70	2.545
80	1.804
90	1.301
100	945
110	704
120	528
125	460

**Connectors and Cable**

Connector I	ASL 6-06-05PN-HE
Connector Loom I	ASL 0-06-05SN-HE
Pin 1	-
Pin 2	Gnd
Pin 3	Sig
Sleeve	DR-25
Cable Size	AWG 24
Cable-Length L	15 – 50 cm

**Application Hint**

The NTC M6 can be connected directly to most control units using a pull-up resistant (typically 1 or 3 kOhm)

Any mounting orientation is possible.

Please find further application hints in the offer drawing (<http://www.bosch-motorsport.com>).

**Part number**

Temperature Sensor NTC M6 **B 261 209 386\_01**

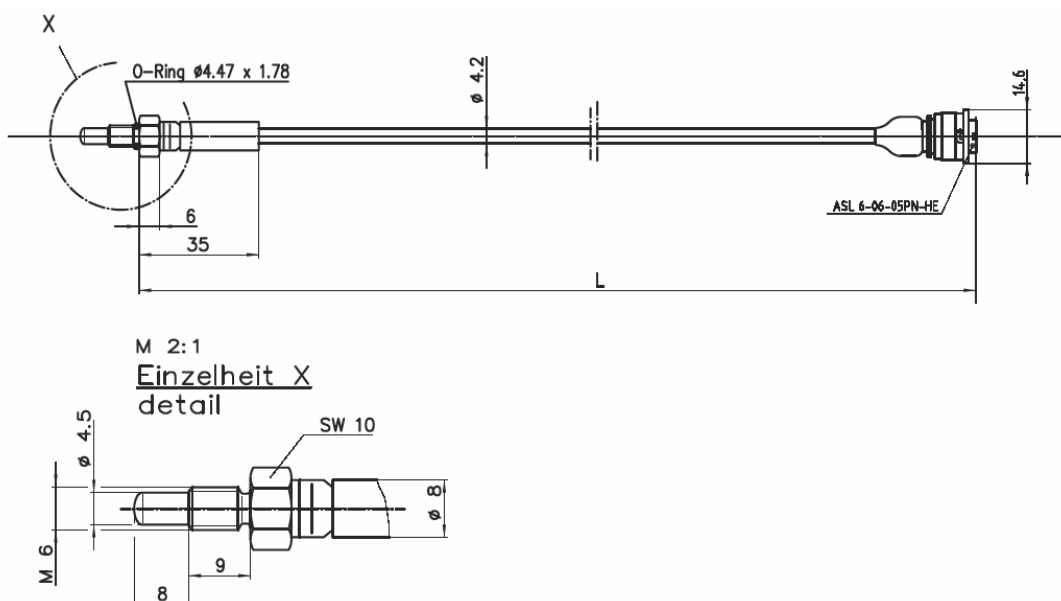

## Temperature Sensor NTC M6-H

A miniature M6 x 1 NTC sensor for fast response temperature measurement. It is manufactured in a DR-25 sleeve, various connector options are available.



Mechanical data	
Thread	M6 x 1
Tightening torque	3 Nm
Wrench size	10 mm
Sealing	Viton 4,47 x 1, 78
Weight	45 g

Conditions for use	
Temperature range	-30 ... 300 °C
Vibration	80 g/5 ... 500 Hz

Electrical data	
Nominal resistance	49 k $\Omega$ /25 °C
Measuring range	0 ... 300 °C
Accuracy	$\pm 1,0$ K
Response time 90 %	< 7 s

Characteristic	
NTC 49 k $\Omega$	

Part number	
ASU 6-03-PB-HE	<b>B 261 209 980</b>

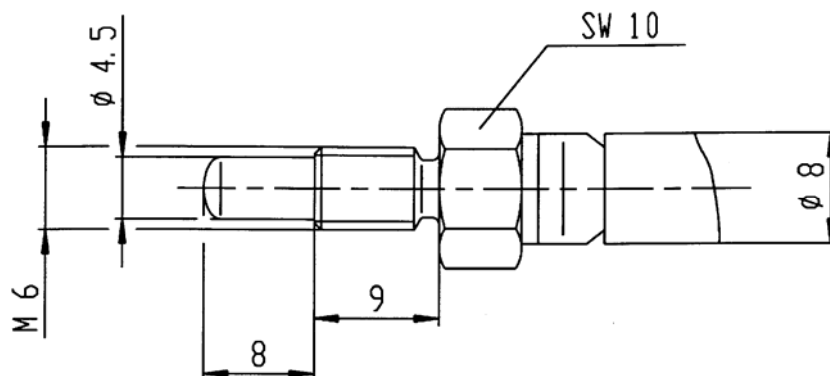

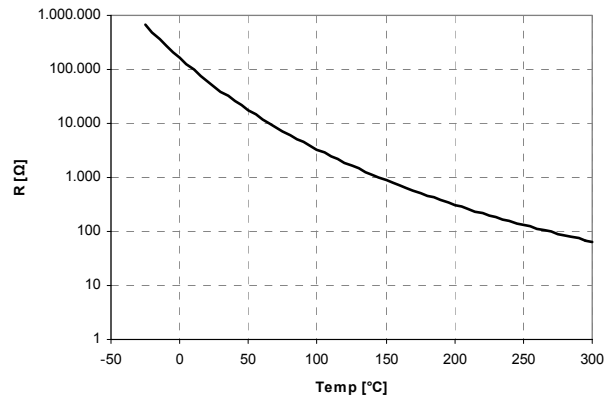

$^{\circ}\text{C}$	$R(\Omega)$
-25	657.350
-20	487.370
-15	365.040
-10	276.060
-5	210.690
0	162.210
5	125.780
10	98.322
15	77.454
20	61.465
25	49.120
30	39.517
35	31.996
40	26.065
45	21.358
50	17.599
55	14.579
60	12.140
65	10.159
70	8.541,5
75	7.214,2
80	6.119,8
85	5.213,4
90	4.459,1
95	3.828,8
100	3.300
105	2.854,5
110	2.477,7
115	2.157,9
120	1.885,5
125	1.652,6
130	1.452,9
135	1.281,1

$^{\circ}\text{C}$	$R(\Omega)$
140	1.132,7
145	1.004,3
150	892,79
155	795,7
160	710,92
165	636,7
170	571,55
175	514,32
180	463,67
185	418,96
190	379,35
195	344,16
200	312,85
205	284,92
210	259,96
215	237,61
220	217,55
225	199,52
230	183,29
235	168,64
240	155,41
245	143,43
250	132,57
255	122,7
260	113,73
265	105,55
270	98,098
275	91,286
280	85,054
285	79,344
290	74,106
295	69,295
300	64,870

## Temperature Sensor NTC M8

This standard fluid temperature sensor combines temperature response with fine mechanical properties. It is manufactured in a DR-25 sleeve, various connector options are available.



Mechanical data	
Thread	M8 x 1
Tightening torque	3 Nm
Wrench size	12 mm
Sealing	Viton 6,35 x 1,78
Weight	45 g

Conditions for use	
Temperature range	-30 ... 200°C
Vibration	80 g/5 ... 500 Hz

Characteristic	
NTC 15 k $\Omega$	

Electrical data	
Nominal resistance	15 k $\Omega$ /25°C
Measuring range	0 ... 200°C
Accuracy	$\pm 1,0$ K
Response time 90 %	< 10 s

Part numbers	
KPSE 6E8-33P-DN	B 261 209 167
Offer drawing	A 261 209 167
KPSE 6E8-3AP-DN	B 261 209 173
Offer drawing	A 261 209 173
ASL 6-06-05PN-HE	B 261 209 384
Offer drawing	A 261 209 384
Without connector	B 261 209 176
Offer drawing	A 261 209 176
ASU 6-03-03PA-HE	B 261 209 978
Offer drawing	A 261 209 978
ASU 6-03-03PN-HE	B 261 209 977
Offer drawing	A 261 209 977

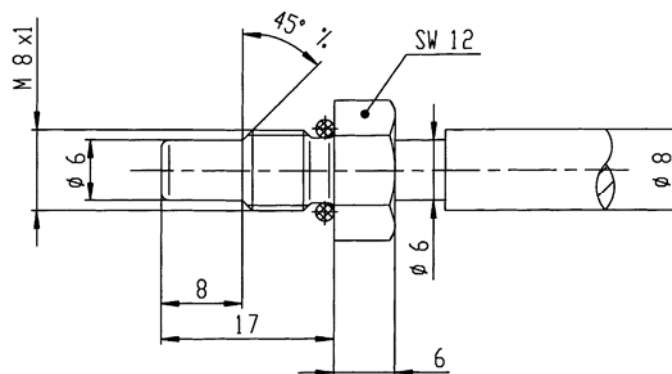

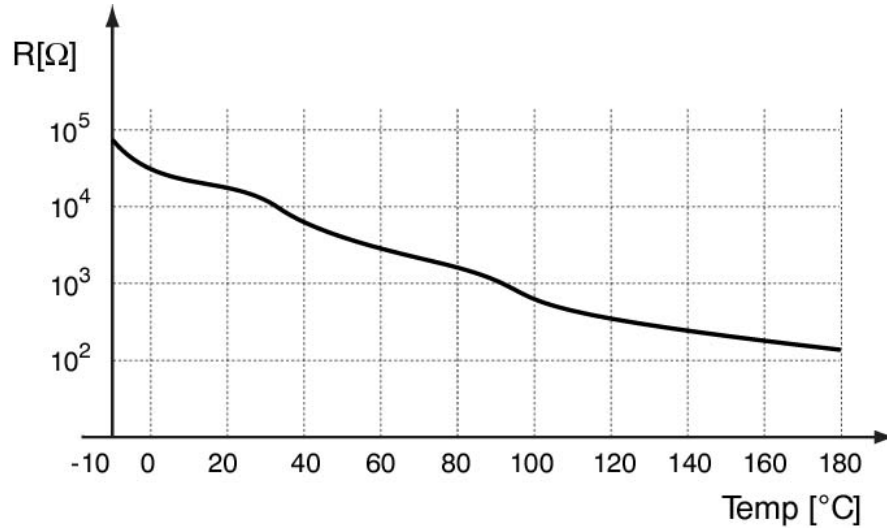

°C	R(Ω)
-10	83317,5
0	49254,0
10	29959,5
20	18732,0
30	12012,0
40	7893,0
50	5356,5
60	3651,0
70	2544,0
80	1804,5

°C	R(Ω)
90	1305,5
100	945,0
110	703,5
120	526,5
130	400,5
140	309,0
150	240,0
160	187,5
170	148,5
180	120,0

# Temperature Sensor NTC M8-F

The NTC M8-F is a development based on the NTC M8. It is created for very fast response air temperature measurement.



Mechanical data	
Thread	M8 x 1
Tightening torque	3 Nm
Wrench size	12 mm
Sealing	Viton 6,35 x 1,78
Weight	45 g

Electrical data	
Nominal resistance	6,8 k $\Omega$ /25 $^{\circ}$ C
Measuring range	0 ... 100 $^{\circ}$ C
Accuracy	$\pm$ 1,0 K
Response time 90 %	< 5 s

Conditions for use	
Temperature range	-30 ... 100 $^{\circ}$ C
Vibration	80 g/5 ... 500 Hz

Part number	
AS 6-06-05PN-HE	<b>B 261 209 818</b>

Characteristic	
NTC 6,8 k $\Omega$	

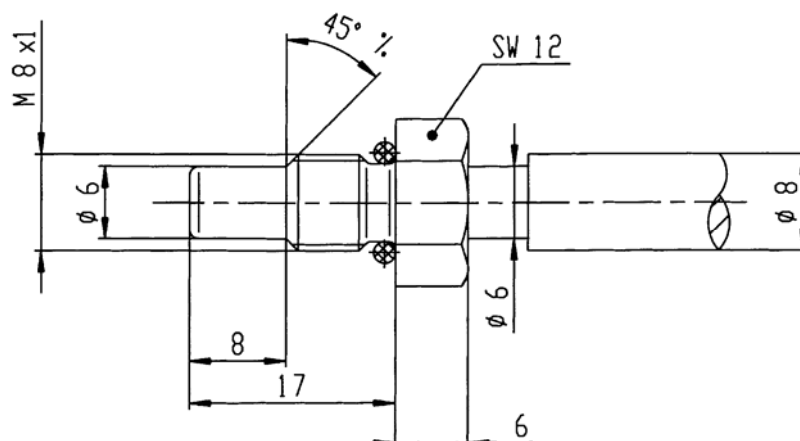



°C	R(Ω)
-20	66115
10	37645
0	22209
10	13533
20	8495
30	5479
40	3624
50	2452
60	1695
70	1195
80	858,2
90	626,7
100	464,8
110	350,4
120	267,1

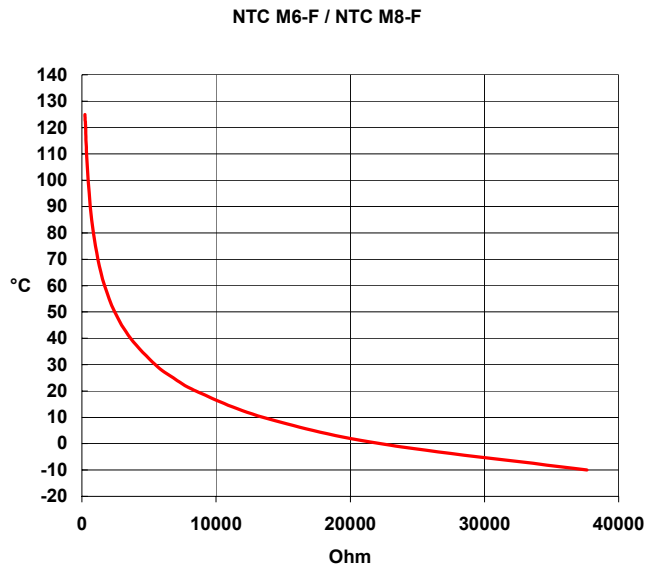

## Temperature Sensor NTC M12

A shockproof sensor for measurements under pressure up to 25 bar. Good thermal conductivity allows fast response temperature measurement. The integrated connector provides a low-cost connection for automotive applications.



General fields of application: oil-, fuel-, water temperature measurement.

Mechanical data	
Thread	M12 x 1,5
Tightening torque	25 Nm
Wrench size	19 mm
Weight	30 g

Conditions for use	
Temperature range	-30 ... 130°C
Vibration	60 g/5 ... 250 Hz

Characteristic	
NTC 2,5 k $\Omega$	

Electrical data	
Nominal resistance	2,5 k $\Omega$ /20°C
Measuring range	-30 ... 130°C
Accuracy	$\pm 1,5$ K
Response time 90 %	< 10 s

Connector	
Cable harness connector	<b>D 261 205 331</b>

Part numbers	
D 261 205 331	<b>O 280 130 026</b>
KPSE 6E8-33P-DN	<b>B 261 209 160</b>
Offer drawing	<b>A 261 209 160</b>

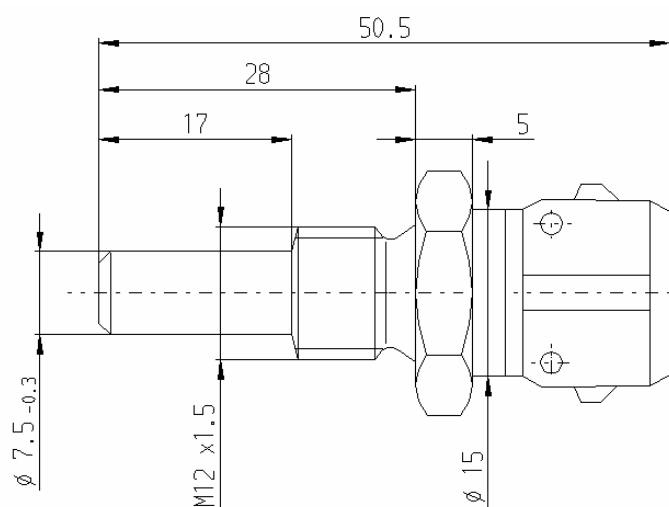

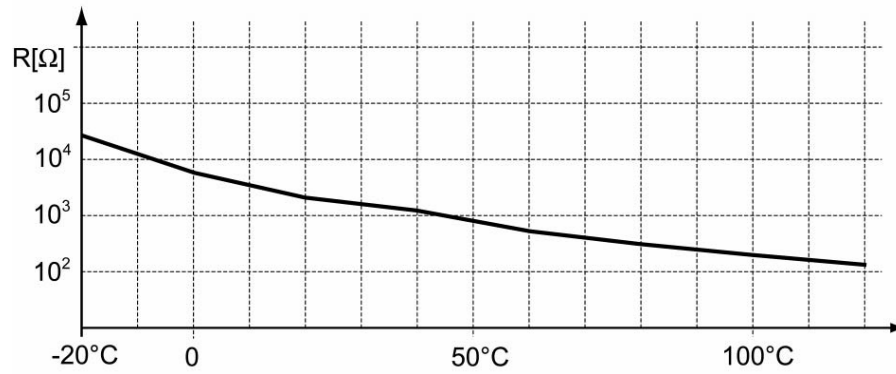

°C	R(Ω)
-40	45 313
-35	34 281
-30	26 114
-25	20 003
-20	15 462
-15	12 002
-10	9 397
-5	7 415
0	5 896
5	4 712
10	3 792
15	3 069
20	2 500
25	2 057
30	1 707
35	1 412
40	1 175
45	987,6
50	833,9
55	702,8
60	595,5

°C	R(Ω)
65	508,3
70	435,7
75	374,2
80	322,5
85	279,6
90	243,2
95	212,7
100	186,6
105	163,8
110	144,2
115	127,3
120	112,7
125	100,2
130	89,30
135	79,65
140	71,20
145	63,86
150	57,41
155	51,82
160	46,88

## Temperature Sensor NTC M12-H

A shockproof sensor for measurements under pressure up to 25 bar. Good thermal conductivity allows fast response temperature measurement. The integrated connector provides a low-cost connection for automotive applications.



General fields of application: oil-, fuel-, water temperature measurement.

Mechanical data	
Thread	M12 x 1,5
Tightening torque	18 Nm
Wrench size	19 mm
Weight	30 g

Electrical data	
Nominal resistance	2,5 k $\Omega$ /20°C
Measuring range	-40 ... +150°C
Accuracy	$\pm 1,5$ K
Response time 90 %	< 10 s

Conditions for use	
Temperature range	-40 ... 150°C
Vibration	30 g/5 ... 250 Hz

Connector	
Cable harness connector	D 261 205 337

Characteristic	
NTC 2,5 k $\Omega$	

Part number	
	0 281 002 170
Offer drawing	A 280 130 110

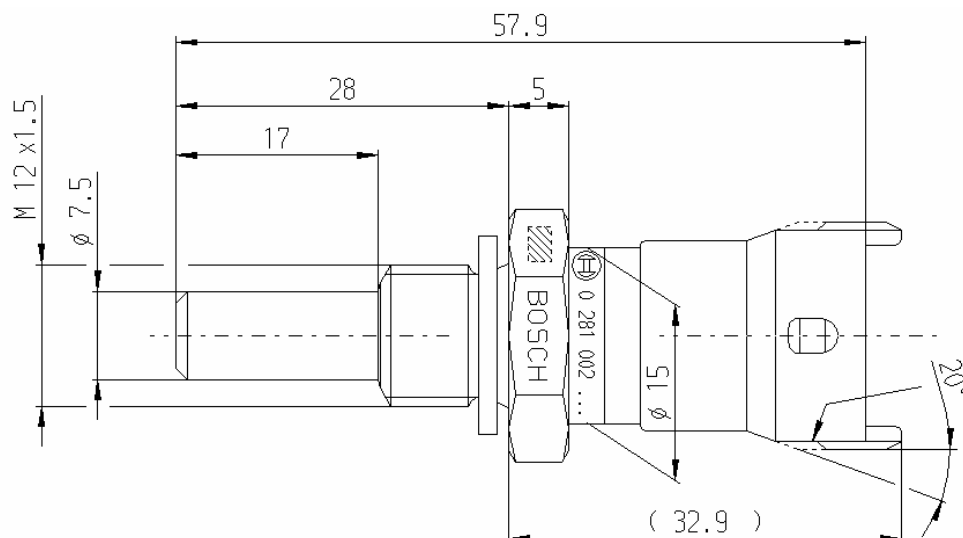

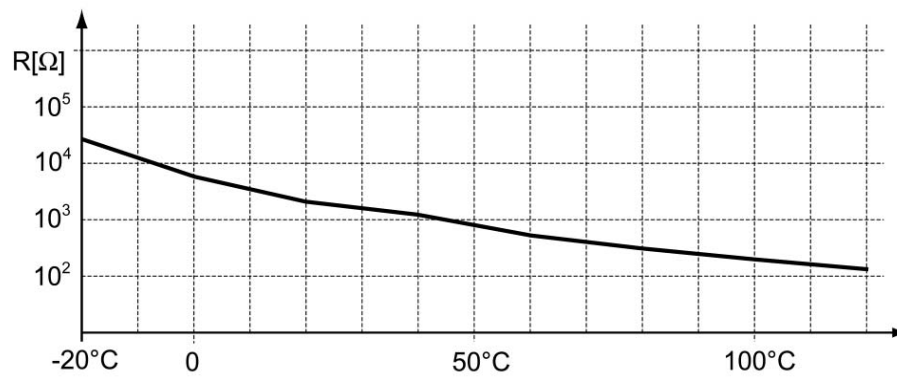

$^{\circ}\text{C}$	$R(\Omega)$
-40	45 313
-35	34 281
-30	26 114
-25	20 003
-20	15 462
-15	12 002
-10	9 397
-5	7 415
0	5 896
5	4 712
10	3 792
15	3 069
20	2 500
25	2 057
30	1 707
35	1 412
40	1 175
45	987,6
50	833,9
55	702,8
60	595,5

$^{\circ}\text{C}$	$R(\Omega)$
65	508,3
70	435,7
75	374,2
80	322,5
85	279,6
90	243,2
95	212,7
100	186,6
105	163,8
110	144,2
115	127,3
120	112,7
125	100,2
130	89,30
135	79,65
140	71,20
145	63,86
150	57,41
155	51,82
160	46,88

## Temperature Sensor NTC M12-L

A shockproof sensor for measurements under pressure up to 25 bar. Good thermal conductivity allows fast response temperature measurement. The integrated connector provides a low-cost connection for automotive applications.



General fields of application: oil-, fuel-, air temperature measurement

Mechanical data	
Thread	M12 x 1,5
Tightening torque	15 Nm
Wrench size	19 mm
Weight	26 g
Conditions for use	
Temperature range	-30 ... 130°C
Vibration	60 g/50 ... 250 Hz
Characteristic	
NTC 2,5 kΩ	

Electrical data	
Nominal resistance	2,5 kΩ/20°C
Measuring range	-30 ... 130°C
Accuracy	± 1,5 K
Response time 90 %	< 10 s
Connector	
Cable harness connector	<b>D 261 205 288</b>
Part number	
	<b>0 280 130 039</b>
Offer drawing	<b>A 280 130 206</b>

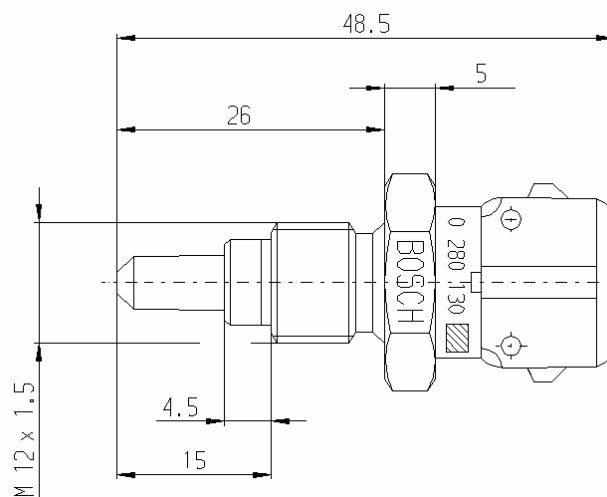

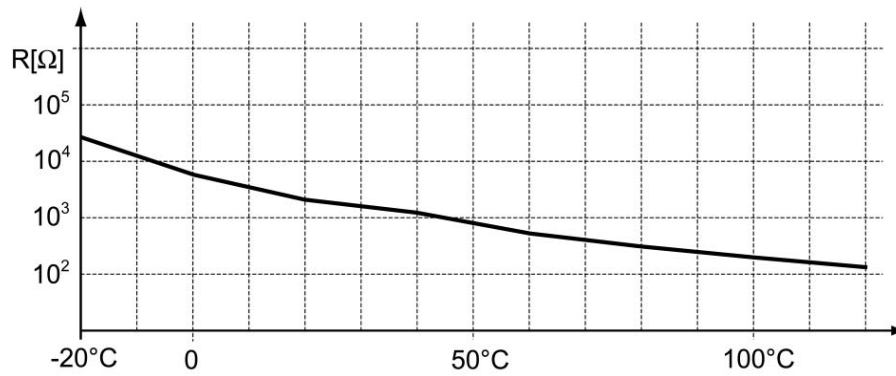

°C	R(Ω)
-40	45 313
-35	34 281
-30	26 114
-25	20 003
-20	15 462
-15	12 002
-10	9 397
-5	7 415
0	5 896
5	4 712
10	3 792
15	3 069
20	2 500
25	2 057
30	1 707
35	1 412
40	1 175
45	987,6
50	833,9
55	702,8
60	595,5

°C	R(Ω)
65	508,3
70	435,7
75	374,2
80	322,5
85	279,6
90	243,2
95	212,7
100	186,6
105	163,8
110	144,2
115	127,3
120	112,7
125	100,2
130	89,30
135	79,65
140	71,20
145	63,86
150	57,41
155	51,82
160	46,88

## Temperature Sensor PT100 M14

A shockproof sensor for measurements under pressure up to 25 bar. Good thermal conductivity allows fast response temperature measurement. The integrated connector provides a low cost connection for automotive applications.



Mechanical data	
Thread	M14 x 1,5
Tightening torque	15 Nm
Wrench size	19 mm
Weight	25 g

Conditions for use	
Temperature range	-50 ... 300°C
Vibration	40 g/5Hz ... 2kHz

Characteristic	
PT 100 DIN/IEC 751	

Electrical data	
Nominal resistance	100 $\Omega$ /0°C
Measuring range	-50 ... 300°C
Accuracy	$\pm 3,0$ K
Response time 90 %	< 10 s

Connector	
Cable harness connector	<b>D 261 205 288</b>

Part number	
	<b>B 261 209 174</b>
Offer drawing	<b>A 261 209 174</b>

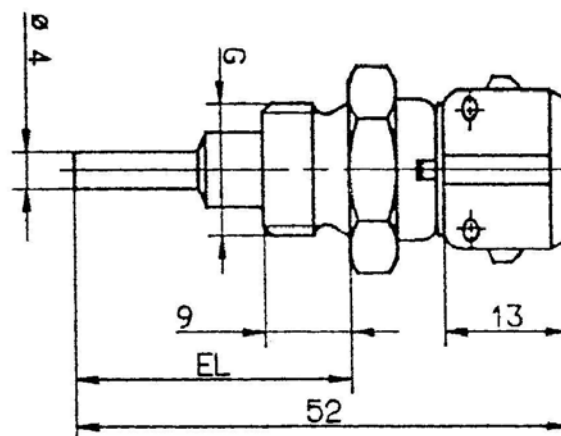



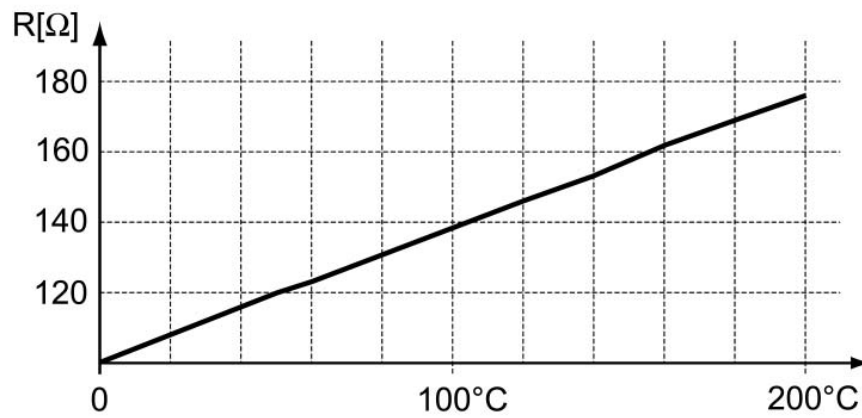

°C	R(Ω)
0	100,00
10	103,90
20	107,79
30	111,67
40	115,54
50	119,40
60	123,24
70	127,07
80	130,89
90	134,70
100	138,50

°C	R(Ω)
110	142,29
120	146,06
130	149,82
140	153,58
150	157,31
160	161,04
170	164,76
180	168,46
190	172,16
200	175,84

# Thermocouple Probes

## Thermocouple Probe TCP-K

A flexible K-type thermocouple for measuring exhaust-gas temperatures. The installation fitting allows an adjustable gas-tight mounting at the exhaust pipe. It is manufactured in a DR-25 sleeve, various connector options are available. The sensor length can be modified on request.



### Mechanical data

Thread	M8 x 1
Tightening torque	12 Nm
Wrench size	13 mm
Weight	18 g

### Cutting ring

Tightening torque	2,5 Nm
Wrench size	11 mm

### Electrical data

Thermocouple	NiCr-Ni
--------------	---------

### Characteristic

DIN IEC 584

### Sensor data

Vibration	80 g/5 ... 500 Hz
Length L	150 ... 740 mm
Weight	60 g

### Part numbers

KPTA 6E6-4SW-C-DN	B 261 209 169
Offer drawing	A 261 209 169
AS 6-06-98PN	B 261 209 179
Offer drawing	A 261 209 179
AS 6-06-05PD-HE	B 261 209 385
Offer drawing	A 261 209 385
ASU 6-03-03-SD-HE	B 261 209 979
Offer drawing	A 261 209 979
Installation fitting	B 261 209 159
Offer drawing	A 261 209 159

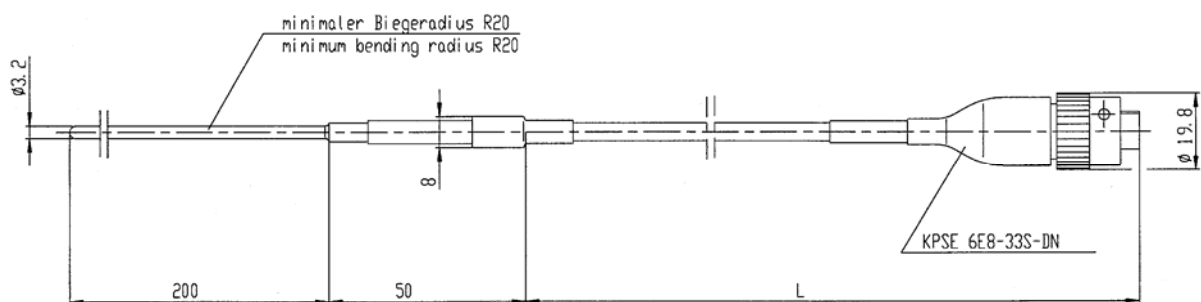

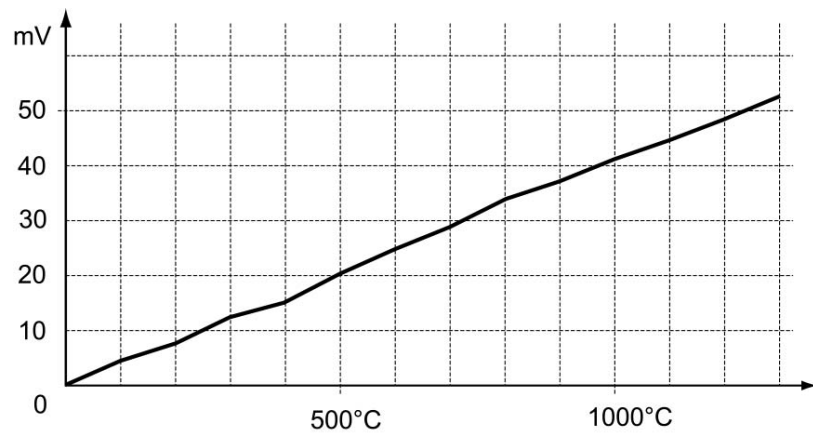

Input °C	Output mV
0	0
100	4,095
200	8,137
300	12,207
400	16,395
500	20,640
600	24,902

Input °C	Output mV
700	29,128
800	33,277
900	37,325
1000	41,269
1100	45,108
1200	48,828
1300	52,398

# Thermocouple Probe TCP-N / TCP-NF

A flexible N-type thermocouple for measuring of exhaust-gas temperatures.

TCP-NF is used in FIA F3 since 2005.



### Mechanical data

Thread	M12 x 1
Tightening torque	15 Nm
Wrench size	17 mm
Length	630 mm
Weight	60 g

### Conditions for use

Vibration	80 g/5 ... 500 Hz
DIN EN 60584	
Temperature range	-40 ... 115 °C

### Characteristic

DIN IEC 584	
-------------	--

### Electrical data

Power supply	12 V
Full scale output	0,5 ... 4,5 V
Thermocouple	NiCrSi-NiSi
Measuring range	-40 ... 1100 °C
<b>Response time:</b>	
TCP-N	20 s
TCP-NF	33 s

### Connector

TCP-N	1-J0973-70
TCP-NF	D 261 205 276

### Part numbers

TCP-N	<b>B 261 209 387</b>
TCP-NF	<b>B 261 209 821</b>

### Design TCP-N

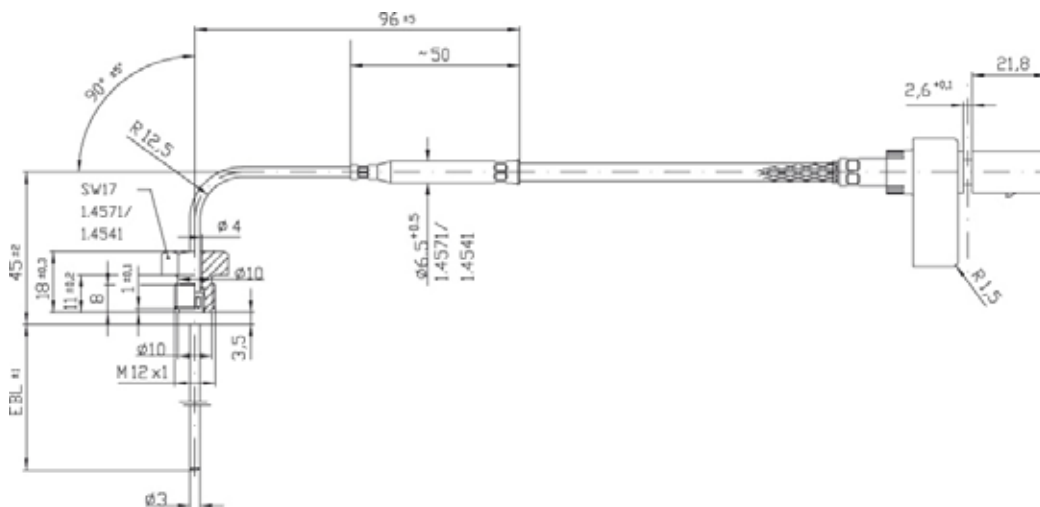

Design TCP-NF

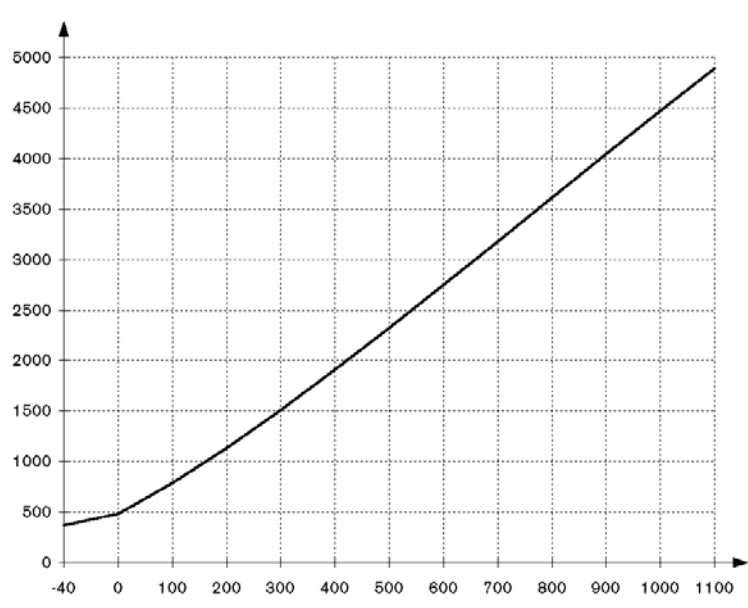
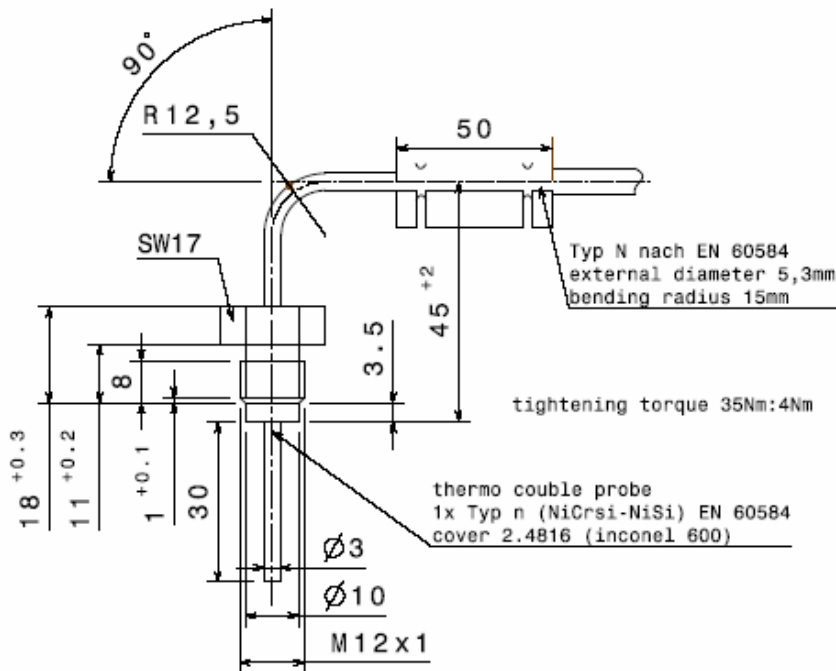

Input °C	Output mV
-40	372
0	485
100	790
200	1135
300	1513
400	1912
500	2327

Input °C	Output mV
600	2752
700	3183
800	3615
900	4046
1000	4473
1100	4845

# Speed Sensors Inductive

## Inductive Speed Sensor IA

This sensor is designed for incremental measurement of revolutions and angles at engine and chassis applications. It is available in a DR-25 sleeve with various connector options and different installation depths.



Mechanical data	
Magnetic pole	round
Drill diameter	12,9 mm
Tightening torque	8 Nm
Weight	70 g
Installation depth L2	13,2/24,1/32,2/41,5 mm

Conditions for use	
Temperature range	-40 ... 230°C
Vibration	80 g/max. 80 h

Electrical data	
Electrical strength	1200 V/max. 3 sec.
Resistance	Ri = 1200 Ω
Inductance	max. 400 mH

Part numbers	
<b>L2: 24, 1 mm</b>	
KPTA 6E6-4SW-C-DN	B 261 209 500
Offer drawing	A 261 209 500
KPSE 6E8-3AS-DN	B 261 209 023
Offer drawing	A 261 209 023
<b>L2: 32,2 mm</b>	
AS 6-06-05SN-HE	B 261 209 519
Offer drawing	A 261 209 519
KPSE 6E8-3AS-DN	B 261 209 022
Offer drawing	A 261 209 022

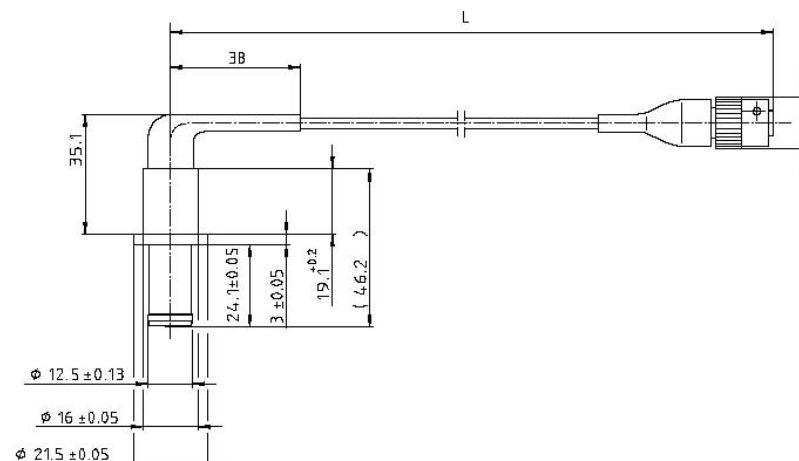

## Inductive Speed Sensor IA-C

This sensor is designed for incremental measurement of revolutions at engine applications.



### Mechanical data

Magnetic pole	round
Fixing	M6 x 12
Length	510 mm
Tightening torque	8 Nm
Weight	80 g
Installation depth	24 mm

### Conditions for use

Temperature range	-40 ... 130 °C
Vibration	80 g/max. 80 h

### Electrical data

Resistance	860 $\Omega$ /20° $\pm$ 10 %
Inductance	370 $\pm$ 60 mH/1 kHz

### Connector

Cable harness connector	D 261 205 334
-------------------------	---------------

### Part number

IA-C	0 261 210 136
------	---------------

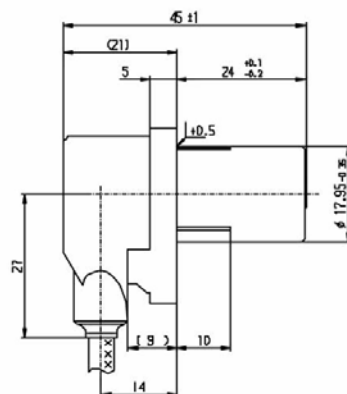
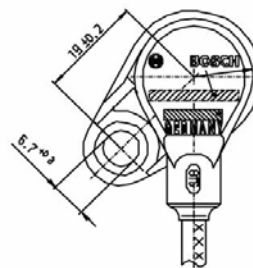
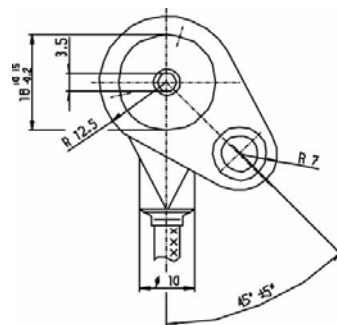

## Inductive Speed Sensor IS

This sensor is designed for incremental measurements of revolutions and angles at engine and chassis applications. It is available in a DR-25 sleeve with various connector options and different installation depths.



Mechanical data	
Magnetic pole	round
Drill hole	12,9 mm
Tightening torque	8 Nm
Weight	70 g
Installation depth L2	13,2/24,1/32,2 mm

Conditions for use	
Temperature range	-40 ... 230°C
Vibration	80 g/max. 80 h

Electrical data	
Electrical strength	1200 V/max. 3 sec.
Resistance	Ri = 1200 Ω
Inductance	max. 400 mH

Part numbers	
<b>L2: 24,1 mm</b>	
KPTA 6E6-4SW-C-DN	B 261 209 509
Offer drawing	A 261 209 509
<b>L2: 32,2 mm</b>	
AS6-06-05SN-HE	B 261 209 517
Offer drawing	A 261 209 517
KPTA 6E6-4SW-C-DN	B 261 209 501
Offer drawing	A 261 209 501
KPSE 6E8-3AS-DN	B 261 209 021
Offer drawing	A 261 209 021

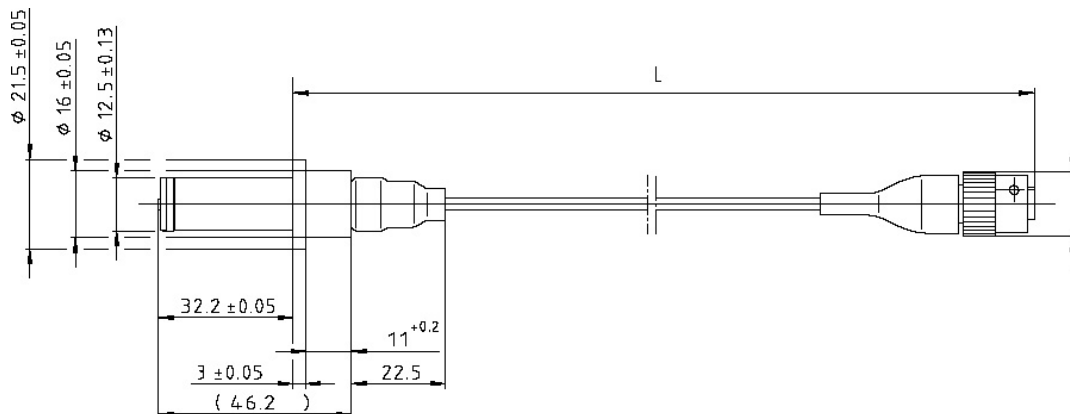



## Inductive Speed Sensor IS-C

This sensor is designed for incremental measurement of revolutions at chassis applications. We manufacture one version with a metric thread and a second version with an inch thread. The sensor is available in a DR-25 sleeve with various connector options.



Mechanical data	
Magnetic pole	round
Drill hole or	M10 x 1 3/8-24 UNF-2A THD (USA)
Mounting torque	10 Nm (7.3 ft-lb) maximum
Weight	16 g

Conditions for use	
Temperature range	-40 ... 150°C

Electronic data	
Resistance	$R_i = 340 \Omega \pm 20 \%$
Inductance	64 mH $\pm 20 \%$

Order numbers	
<b>M10 x 1</b>	
KPTA 6E6-4SW-C-DN	<b>B 261 209 624</b>
Offer drawing	<b>A 261 209 624</b>
<b>3/8-24 UNF-2A THD</b>	
AS 6-06-05 SN-HE	<b>B 261 209 609</b>
Offer drawing	<b>A 261 209 609</b>

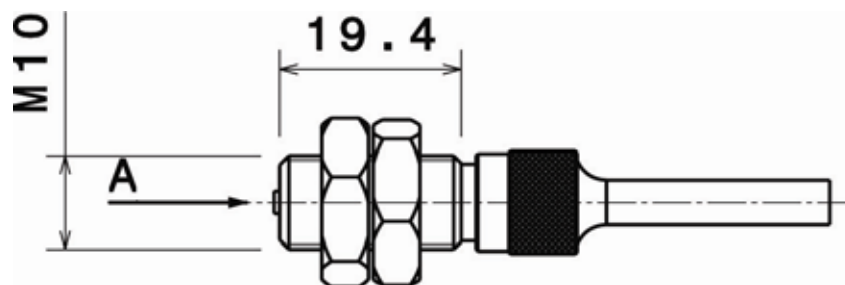

## Inductive Speed Sensor IS-T

This sensor is designed for incremental measurements of revolutions at turbochargers. It is available in a DR-25 sleeve with various connector options.



### Mechanical data

Magnetic pole	round
Fixing	not defined
Drill diameter	250-40UNS-2ATHD
Length	150 ... 600 mm
Wrench size	8 mm
Tightening torque	1,4 Nm
Weight	14 g
Air gap	0,5 mm, 2 kΩ load, 0,75 V pk-pk

### Conditions for use

Temperature range	-54 ... 230°C
-------------------	---------------

### Electrical data

Resistance	140 ... 190 Ω
Inductivity	2,6 mH (typical)

### Part number

AS 6-06-05SN-HE	<b>B 261 209 662</b>
Offer drawing	<b>A 261 209 662</b>
ASU 603 03-SB-HE	<b>B 261 209 665</b>
Offer drawing	<b>A 261 209 665</b>

# Speed Sensors Hall-effect

## Speed Sensor HA-M

This sensor is designed for incremental measurement of revolutions and angles at engine and chassis applications.

Due to the rotation of a ferromagnetic target wheel in front of the HA-M the magnetic field is modulated at the place of the Hall probe. We offer two different types of sensor signal outputs: active-low and active-high.



Mechanical data	
Fixing	M6
Drill hole	11,8 mm
Max. distance	1,2 mm
Tightening torque	6 Nm
Weight	12 g

Conditions for use	
Temperature range	-40 ... 160 °C
N min	0 rpm (CAM)
N max	6.000 rpm (CAM)
Target wheel: air gap	0,5 ... 1,5 mm

**Please notice**  
 Stray magnetic fields have an influence on the switching behaviour of the sensor element.

Electrical data	
Power supply	5 ... 18 V
Input current	5,6 mA
Signal output high level	4,2 V
Signal output low level	0,52 V

Connectors and Cables	
Sleeve	DR-24
Connector	ASU 6-03-03PN-HE
Various military and automotive connectors on request.	

Part numbers	
Active-low	<b>B 261 209 283</b>
Active-high	<b>B 261 209 295</b>

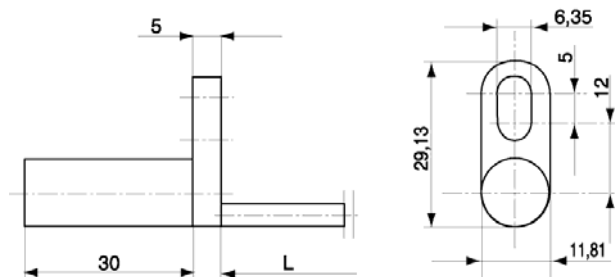

## Speed Sensor HA-P

This sensor is designed for incremental measurement of revolutions and angles at engine and chassis applications.



Mechanical data	
Fixing	M6
Drill hole	18 mm
Max. distance	1,52 mm
Tightening torque	6 Nm
Weight	70 g
Installation dimensions	30 mm

Conditions for use	
Temperature range	-30 ... 130 °C
Vibration	100 g/10 Hz ... 2 kHz
Air gap	max. 1,5 mm

Electrical data	
Power supply	4,5 ... 24 V
Input current	10 mA typ., 20 mA max.
Signal output (active)	0,4 V max.
Output current	20 mA max.

Connector	
Cable harness connector	<b>D 261 205 335</b>

Part number	
HA-P	<b>0 232 103 037</b>
Offer drawing	A 232 090 314

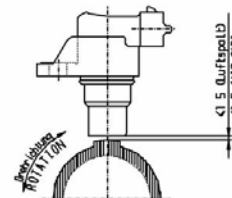
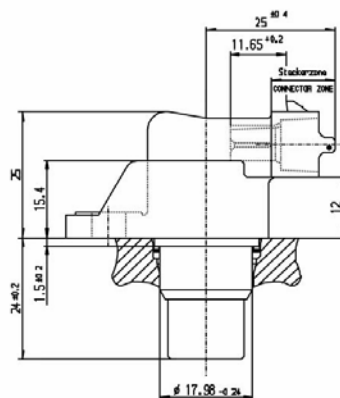
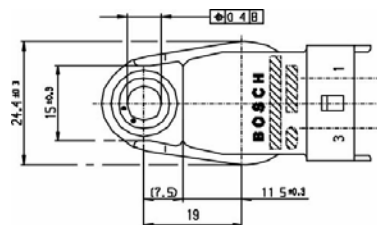

# Lambda Sensors

## Lambda Sensor LSM 11

A lambda LSM 11 standard production sensor, manufactured in a DR-25 sleeve with a series connector.



Mechanical data	
Length	250 ... 1390 mm
Thread	M18 x 1,5
Tightening torque	60 Nm
Wrench size	22 mm
Weight	160 g
Vibration	30 g/5 Hz ... 2 kHz

Fuel additives	
Sulphur (weight)	0,2 %
Lead	0,6 g/l

Temperature ranges	
Ceramic tip	250 ...850°C
Hexagon nut	< 570°C
Cable duct	< 250°C
Connector	< 130°C

Electrical data	
Heater supply voltage	12 ... 14 V
Heater power	18 W
Sensor element	ZrO <sub>2</sub> (Zirconium-Oxide-Ceramic)
Lambda measuring range	0,68 ... 1,32
Accuracy at lambda < 1	< 1,5 %

Connectors	
	1 284 485 110
	1 224 485 018

Part number	
	0 258 104 002
Offer drawing	A 258 104 002

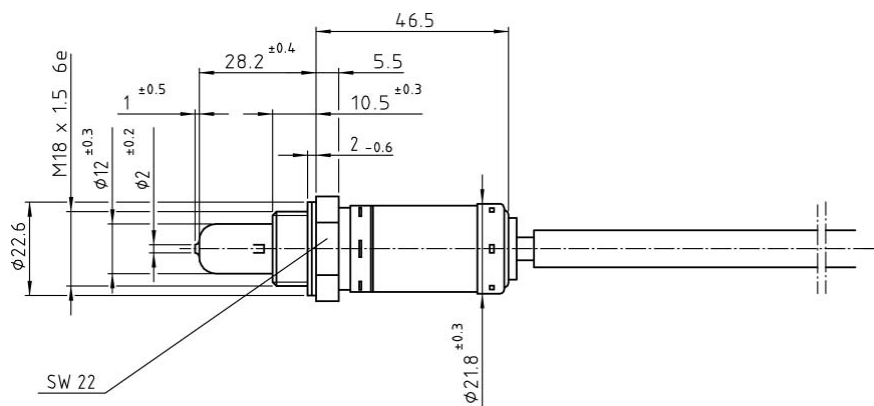

### Installation instructions

The Lambda sensor should be installed at a point which permits the measurement of a representative exhaust-gas mixture, and which does not exceed the maximum permissible temperature. The sensor is screwed into a mating thread and tightened with 50 ... 60 Nm.

- Install at a point where the gas is as hot as possible.
- Observe the maximum permissible temperatures.
- As far as possible install the sensor vertically, whereby the electrical connections should point upwards.
- The sensor is not to be fitted near to the exhaust outlet so that the influence of the outside air can be ruled out. The exhaust-gas passage opposite the sensor must be free of leaks in order to avoid the effects of leak-air.
- Protect the sensor against condensation water.
- The sensor body must be ventilated from the outside in order to avoid overheating.
- The sensor is not to be painted, nor is wax to be applied or any other forms of treatment. Only the recommended grease is to be used for lubricating the threads.
- The sensor receives the reference air through the connection cable. This means that the connector must be clean and dry. Contact spray, and anti-corrosion agents etc. are forbidden.

The connection cable must not be soldered. It must only be crimped, clamped, or secured by screws.

## Lambda Sensor LSM 11-PM

A lambda LSM 11 standard production sensor, manufactured in a DR-25 sleeve, various connector options are available.



Mechanical data	
Length	250 ... 1390 mm
Thread	M18 x 1,5
Tightening torque	60 Nm
Wrench size	22 mm
Weight	160 g
Vibration	30 g/5 Hz ... 2 kHz

Fuel additives	
Sulphur (weight)	0,2 %
Lead	0,6 g/l

Temperature ranges	
Ceramic tip	250 ... 800°C
Hexagon nut	< 570°C
Cable duct	< 250°C
Connector	< 130°C

Electrical data	
Heater supply voltage	12 ... 14 V
Heater power	18 W
Sensor element	ZrO <sub>2</sub> (Zirconium-Oxide-Ceramic)
Lambda measuring range	0,68 ... 1,32
Accuracy at lambda < 1	< 1,5 %

Installation instructions	
Please observe the installation instructions of Lambda Sensor LSM 11.	

Part number	
KPTC 6E8-4P-C-DN	<b>B 261 209 105</b>
Offer drawing	<b>A 261 209 105</b>

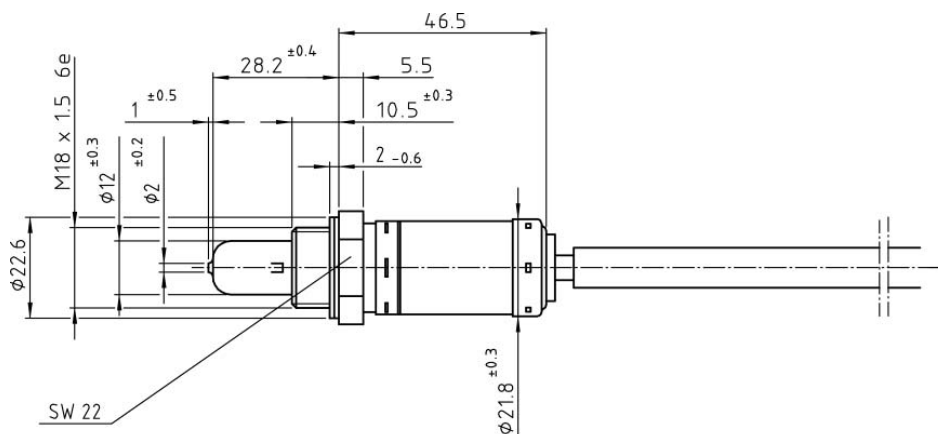

# Lambda Sensor LSM 11-RM

An individually selected wide-band LSM 11 lambda sensor. It is specially modified for motorsport use, manufactured in a Viton sleeve. Various connector options are available.



Mechanical data	
Length	250 ... 1390 mm
Thread	M18 x 1,5
Tightening torque	60 Nm
Wrench size	22 mm
Weight	160 g
Vibration	70 g/5 Hz ... 2 kHz

Fuel additives	
Sulphur (weight)	0,2 %
Lead	0,6 g/l

Temperature ranges	
Ceramic tip	250 ... 850°C
Hexagon nut	< 570°C
Cable duct	< 250°C
Connector	< 130°C

Electrical data	
Heater supply voltage	12 ... 14 V
Heater power	18 W
Sensor element	ZrO <sub>2</sub> (Zirconium-Oxide-Ceramic)
Lambda measuring range	0,68 ... 1,32
Accuracy at lambda < 1	< 1,5 %

**Installation instructions**  
Please observe the installation instructions of Lambda Sensor LSM 11.

Part number	
KPTC 6E8-4P-C-DN	<b>B 261 209 101</b>
Offer drawing	<b>A 261 209 101</b>

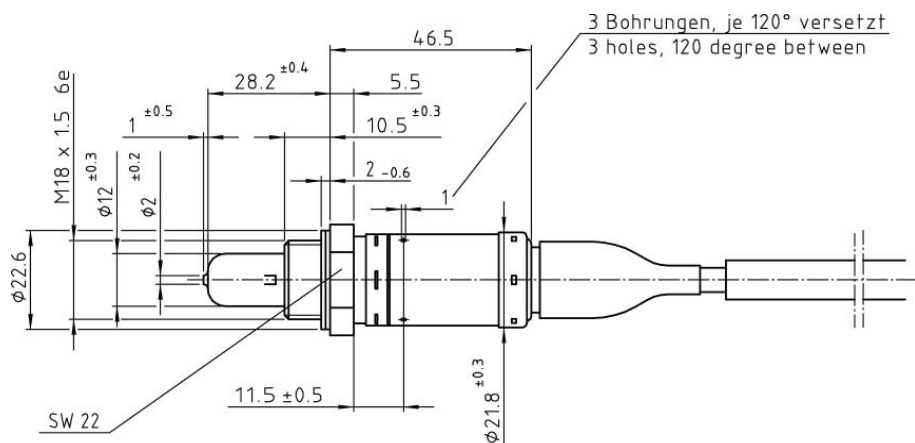



## Lambda Sensor LSU 4.2

The wide-band lambda sensor LSU 4.2 is a planar ZrO<sub>2</sub> dual cell limiting current sensor with integrated heater. It is used to measure the oxygen content and the lambda value of engine exhaust gases. Its output signal in the range of lambda = 0,7 to air makes the LSU capable to be used as an universal sensor for lambda = 1 measurement as well as for other lambda ranges.

The connector module carries a trimming resistor, which defines the characteristics of the sensor and is necessary for the sensor function. The wide band sensor LSU operates only in conjunction with a special control unit.



Mechanical data	
Length incl. cable	460 mm/600 mm
Thread	M18 x 1,5
Tightening torque	60 Nm
Wrench size	22 mm
Weight	120 g
Vibration	30 g/5 Hz ... 2 kHz

Fuel additives	
In accordance with DIN EN 228 for commercially available unleaded fuel.	

Temperature ranges	
Exhaust gas at sensor element	850 °C
Hexagon of the sensor housing	< 570 °C
Cable grommet (PTFE formed house)	
-Sensor side	< 250 °C
-Cable side	< 200 °C
Cable and protection sleeve	< 250 °C
Connector	< 120 °C

Electrical data	
Heater supply voltage	9 V
Heater power	10 W
Sensor element	ZrO <sub>2</sub> (Zirconium-Oxide-Ceramic)
Lambda measuring range	0,70 ... ∞

Installation instructions	
Please observe the installation instructions of Lambda Sensor LSM 11.	

Connector	
Cable harness connector	<b>D 261 205 138</b>

Part numbers	
L: 460 mm	<b>0 258 006 066</b>
L: 600 mm	<b>0 258 006 065</b>
Offer drawing	<b>A 258 400 021</b>

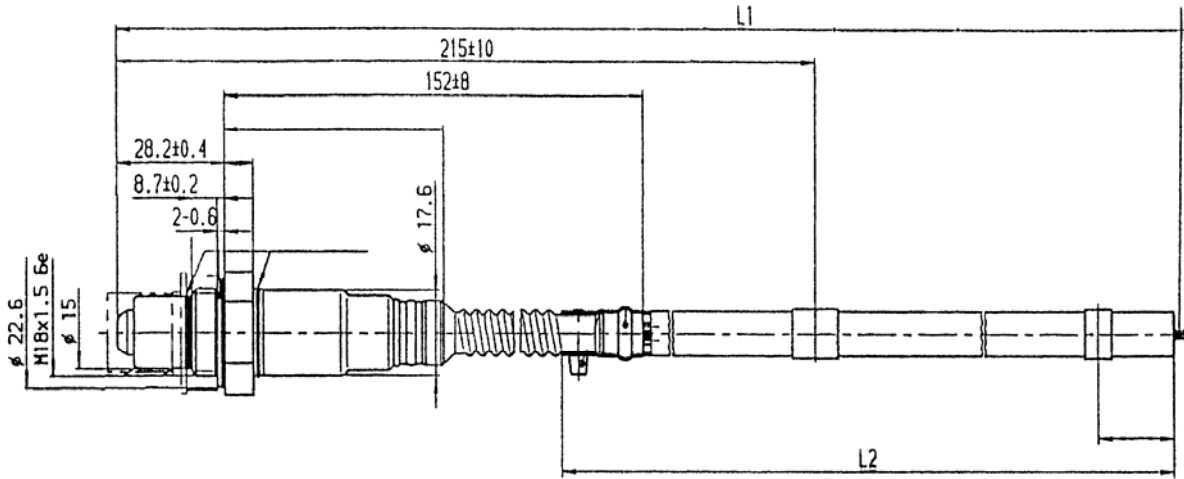

## Lambda Sensor LSU 4.9

This sensor is designed to measure the oxygen content and  $\lambda$ -value of exhaust gases in automotive engines (gasoline or Diesel).

The wide band lambda sensor LSU 4.9 is a planar ZrO<sub>2</sub> dual cell limiting current sensor with integrated heater. Its monotonic output signal in the range of  $\lambda = 0,65$  to air makes the LSU capable of being used as an universal sensor for  $\lambda = 1$  measurement as well as for other  $\lambda$  ranges. The connector module contains a trimming resistor, which defines the characteristic of the sensor. The LSU operates only in combination with a special LSU-IC, used in most Bosch Motorsport ECUs and lambda control boxes (LT4).



Application	
Application	0,65 ... $\infty$
Fuel	Fuel/Diesel
Exhaust Gas Pressure	< 4 bar
Exhaust Gas Temperature Range (Operating)	< 930 °C
Exhaust Gas Temperature Range (Maximum)	< 1030 °C
Hexagon Temperature	< 600 °C
Cable and protective Sleeve Temperature	< 250 °C
Connector Temperature	< 140 °C
Storage Temperature Range	-40 ... 100 °C
Max. Vibration (stochastic peak level)	< 100 g

Mechanical data	
Weight w/o Cable	120 g
Length	84 mm
Thread	M18 x 1,5
Wrench Size	22 mm
Tightening Torque	40 ... 60 Nm

Electrical data	
Power Supply H+ Nominal	7,5 V
System Supply Voltage H+ (min)	10,8 V
Heater Power steady state	7,5 W
Heater Control Frequency	$\geq 100$ Hz
Nominal Resistance of Nernst Cell	300 Ohm
Max Current load for Nernst Cell	250 $\mu$ A

### Connectors and Cables

Connector	AS 6-07-35PN
Connector Loom	AS 6-07-35SN
Pin 1	Uh+
Pin 2	Uh-
Pin 3	APE
Pin 4	IPN
Pin 5	RE
Pin 6	R
Sleeve	Fiber Glas / Silicon coated
Cable Size	22
Cable Length L	30 ... 100 cm

### Application Hint

The LSU4.9 can be connected to all Bosch Motorsport ECUs (MS 4, MS 5, MS 15) and lambda control units (AWS) like LT4.

The lambda sensor should be installed at point which permits the measurement of a representative exhaust-gas mixture, which does not exceed the maximum permissible temperature.

Install at a point where the gas is as hot as possible.

Observe the maximum permissible temperature.

As far as possible install the sensor vertically (cable upwards).

The sensor is not to be fitted near to the exhaust pipe outlet, so that the influence of the outside air can be ruled out.

The exhaust-gas passage opposite the sensor must be free of leaks in order to avoid the effects of leak-air.

Protect the sensor against condensation water.

The sensor is not to be painted, nor is wax to be applied or any other forms of treatment. Use only the recommended grease for lubricating the thread.

Please find further application hints in the offer drawing (<http://www.bosch-motorsport.com>).

### Characteristic

Signal Output	Ip meas / Ua (AWS)
Accuracy @ lambda = 1	1,016 +/- 0,007
Accuracy @ lambda = 0,8	0,80 +/- 0,01
Accuracy @ lambda = 1,7	1,70 +/- 0,05

IP	UA [V]	Lambda
-1,243	0,192	0,750
-0,927	0,525	0,800
-0,800	0,658	0,822
-0,652	0,814	0,850
-0,405	1,074	0,900
-0,183	1,307	0,950
-0,106	1,388	0,970
-0,040	1,458	0,990
0,000	1,500	1,003
0,015	1,515	1,010
0,097	1,602	1,050
0,193	1,703	1,100
0,250	1,763	1,132
0,329	1,846	1,179
0,671	2,206	1,429
0,938	2,487	1,701
1,150	2,710	1,990
1,385	2,958	2,434
1,700	3,289	3,413
2,000	3,605	5,391
2,150	3,762	7,506
2,250	3,868	10,119

### Part number

LSU 4.9	<b>B 261 209 356</b>
---------	----------------------

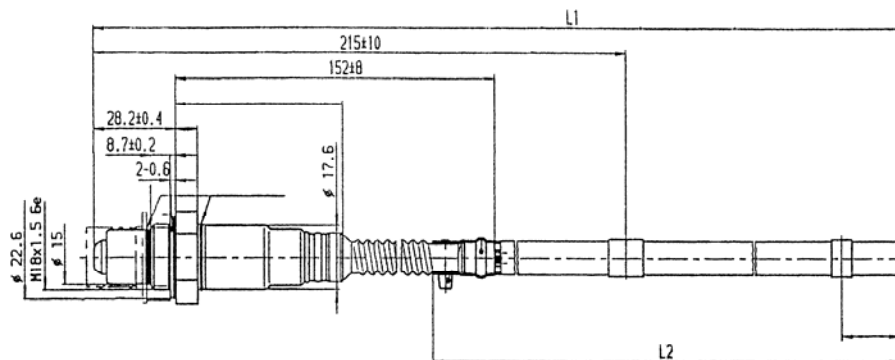

## Lambda Sensor Mini-LSU 4.9

This sensor is designed to measure the oxygen content and  $\lambda$ -value of exhaust gases in automotive engines (gasoline or Diesel).

The wide band lambda sensor Mini-LSU 4.9 is a planar  $ZrO_2$  dual cell limiting current sensor with integrated heater. Its monotonic output signal in the range of  $\lambda = 0,65$  to air makes the LSU capable of being used as an universal sensor for  $\lambda = 1$  measurement as well as for other  $\lambda$  ranges. The connector module contains a trimming resistor, which defines the characteristic of the sensor. The LSU operates only in combination with a special LSU-IC, used in most Bosch Motorsport ECUs and lambda control boxes (LT4, AWS\_LSU 4.9 e.g.).

The main benefit of the Mini-LSU 4.9 is the very compact design combined with the high Bosch production quality standard.



Application	
Application	0,65 ... $\infty$ lambda
Fuel	Gasoline / Diesel
Exhaust Gas Pressure	< 4 bar
Exhaust Gas Temperature Range (Operating)	< 930 °C
Exhaust Gas Temperature Range (Maximum)	< 1.030 °C
Hexagon Temperature	< 1.050 °C
Cable and Protective Sleeve Temperature	< 250 °C
Connector Temperature	< 150 °C
Storage Temperature Range	-40 ... 100 °C
Max. Vibration (stochastic peak level)	< 100 m/s <sup>2</sup>

Mechanical data	
Weight w/o Cable	28 g
Length	60 mm
Thread	M16 x 1,5
Wrench Size	17 mm
Tightening Torque	60 Nm

Electrical data	
Power Supply H+ Nominal	7,5 V
System Supply Voltage H+ (min)	10,8 V
Heater Power steady state	7,5 W
Heater Control Frequency	$\geq$ 100 Hz
Nominal Resistance of Nernst Cell	300 Ohm
Max. Current Load for Nernst Cell	250 $\mu$ A

**Characteristic**

Signal Output	Ip meas / Ua (AWS)
Accuracy @ lambda = 1	1,016 +/- 0,007
Accuracy @ lambda = 0,8	0,80 +/- 0,01
Accuracy @ lambda = 1,7	1,70 +/- 0,05

IP	UA [V]	Lambda
-1,243	0,192	0,750
-0,927	0,525	0,800
-0,800	0,658	0,822
-0,652	0,814	0,850
-0,405	1,074	0,900
-0,183	1,307	0,950
-0,106	1,388	0,970
-0,040	1,458	0,990
0,000	1,500	1,003
0,015	1,515	1,010
0,097	1,602	1,050
0,193	1,703	1,100
0,250	1,763	1,132
0,329	1,846	1,179
0,671	2,206	1,429
0,938	2,487	1,701
1,150	2,710	1,990
1,385	2,958	2,434
1,700	3,289	3,413
2,000	3,605	5,391
2,150	3,762	7,506
2,250	3,868	10,119

**Connectors and Cables**

Connector	1 928 404 682
Connector Loom	09 4421 01
Pin 1	IP
Pin 2	VM
Pin 3	UH-
Pin 4	UH+
Pin 5	RT
Pin 6	UN
Sleeve	Fiber Glas / Silicon coated
Cable Size	22
Cable Length L	30-100 cm

**Application Hint**

The Mini-LSU 4.9 can be connected to all Bosch Motorsport ECUs (MS 4, MS 5, MS 15) and Lambda Control Units like LT4 or AWS\_LSU 4.9.

The lambda sensor should be installed at point which permits the measurement of a representative exhaust-gas mixture, which does not exceed the maximum permissible temperature.

Install at a point where the gas is as hot as possible.

Observe the maximum permissible temperature.

As far as possible install the sensor vertically (cable upwards).

The sensor is not to be fitted near to the exhaust pipe outlet, so that the influence of the outside air can be ruled out.

The exhaust-gas passage opposites the sensor must be free of leaks in order to avoid the effects of leak-air.

Protect the sensor against condensation water.

The sensor is not to be painted, nor is wax to be applied or any other forms of treatment. Use only the recommended grease for lubricating the thread.

Please find further application hints in the offer drawing (<http://www.bosch-motorsport.com>).

**Part number**

Lambda Sensor Mini-LSU 4.9 **B 258 490 103\_20**

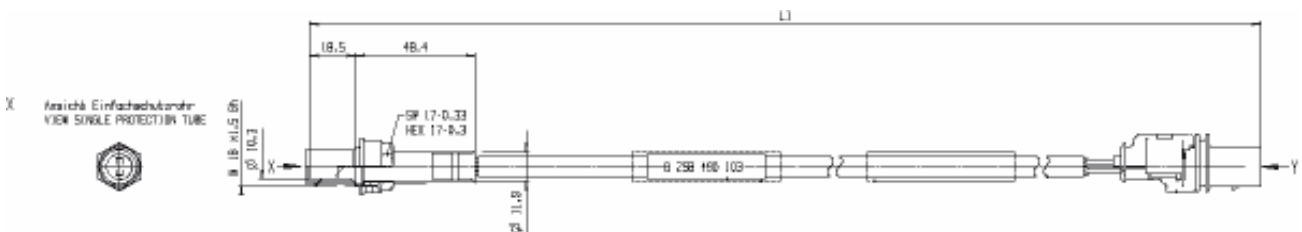

# Knock Sensors

## Knock Sensor KS-P

This sensor is designed to measure the structure borne noise resulted from irregular engine combustion. The robust sensor is suitable for use under extreme conditions.



### Mechanical data

Thread	M8 x 30 (aluminium engine block) M8 x 25 (cast iron engine block)
Weight	48 g
Tightening torque	15 ... 25 Nm
Mounting position	random

### Conditions for use

Temperature range	-40 ... 150°C
Vibration, constant	≤ 80 g
Vibration, short	≤ 400 g

### Electrical data

Main resonance frequency	> 20 kHz
Impedance R:	> 1MΩ
C	1100 ± 300 pF
Measuring range	0,1 ... 400 g
Sensitivity at 5 kHz	26 ± 8 mV/g
Range of frequency	1 ... 20 kHz

### Connector

Cable harness connector	<b>D 261 205 337</b>
-------------------------	----------------------

### Part number

	<b>0 261 231 120</b>
Offer drawing	<b>A 261 230 170</b>

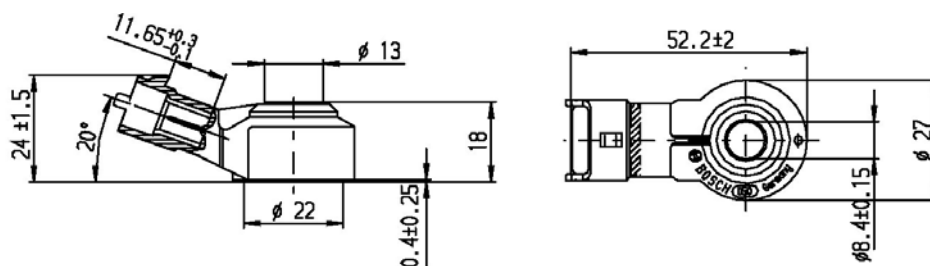

### Beispiel/EXEMPLE

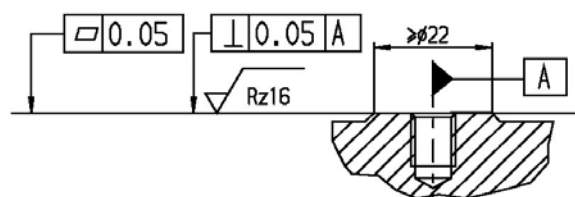

Sensor darf nur auf seinen Metall-  
Flächen aufliegen (keine Sicherungs-  
scheiben verwenden)  
ONLY THE METALLIC PART OF THE  
SENSOR MAY HAVE CONTACT WITH THE  
ENGINE (NO WASHERS ARE TO BE USED)

Auflageflaeche soll rotationssymmetrisch zur Gewindebohrung bearbeitet werden.  
THE CONTACT SURFACE MUST BE MACHINED ROTATIONALLY SYMMETRICAL TO THE THREADED BORE.

## Knock Sensor KS-R

The Sensor is used for detecting vibrations, which appears at the engine if irregular combustions.

The robust sensor is suitable for use under extreme conditions. Due to its inertia, a mass is moving according to the vibration of the engine e.g. and causes a compression force to a piezo ceramic. As a result, a voltage between the upper and lower end of the ceramic can be measured. This voltage is a value for the acceleration.

The main benefit of this sensor is the precise determination of structure-borne noise in a robust mechanical design and small size. Further more the connector is decoupled from the sensor by a cable.



Application	
Application	1 ... 20 kHz
Operating Temp Range	-40 ... 130 °C
Storage Temperature Range	0 ... 100 °C
Max. Vibration	≤ 80 g

Electrical data	
Range of Frequency	1 ... 20 kHz
Sensitivity @ 5 kHz	26 ± 8 mV/g
Max. Sensivity Changing (life time)	-17 %
Linearity between 5 ... 15 kHz (from 5 kHz value)	-10 ... 20 %
Linearity between 15 ... 20 kHz (linear increasing with freq)	20 ... 50 %
Main Resonance Frequency	> 25 kHz
Impedance	> 1 MΩ
Temperature-dependance of sensitivity	-0,06 mV/g °C
Capacity Field	800 ... 1400 pF

Mechanical data	
Male Thread (for cast)	M8 x 25
Male Thread (for Al)	M8 x 30
Installation Torque	20 ± 5 Nm
Weight w/o Cable	82 g
Protection	IP 54

Connectors and Cable	
Connector	A 261 230 076
Connector Loom	D 261 205 289
Pin 1	signal (+)
Pin 2	signal (-)
Pin 3	Scr
Cable-Length L	50 cm
Sleeve	Elastomer
Cable Size	AWG 24



**Application Hint**

The KS-R sensor can be connected to all Bosch Motorsport ECU featuring knock control.

Please make sure, that only the metallic part of the sensor (D = 22 mm) may have contact with the engine.

The sensor should be mounted at a location where it is exposed to liquids such as gasoline, antifreeze, oil brake fluid e.g. only for a short time.

The wire of the sensor should be routed in such a way, that resonance vibration can not occur.

Please find further application hints in the offer drawing (<http://www.bosch-motorsport.com>).

**Part Number**

KS-R

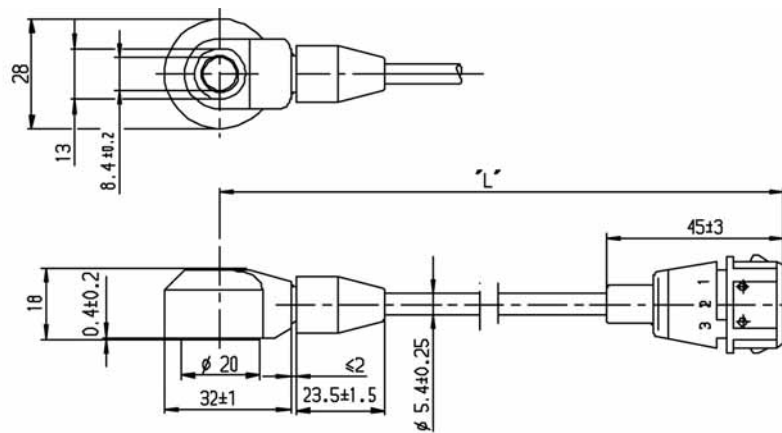
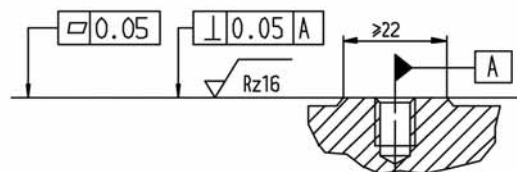
**0 261 231 047**

**Beispiel/example/:**

Sensor darf nur auf seinen Metall-  
flaechen aufliegen (keine Sicherungs-  
scheiben verwenden)  
Only the metallic part of the  
sensor may have contact with the  
engine (no washers are to be used)

Auflageflaeche soll rotationssymmetrisch zur Gewindebohrung bearbeitet werden.  
The contact surface must be machined rotationally symmetrical to the threaded bore.

# Rotary Potentiometers

## Rotary Potentiometer RP 55

This sensor is designed to measure throttle position, chassis data acquisition and more. The sensor is manufactured in aluminium housing. Various range and connector options are available on request.



Mechanical data	
Mounting	2 x M3
Standard shaft	6 mm
Length	160 ... 300 mm
Mech. range	360°
Tightening torque	0,5 Nm
Weight	41 g
Life expectancy	> 50 x 10 <sup>6</sup> rotations

Electrical data	
Nominal resistance	5 kΩ
Resistance tolerance	20 %
Linearity	± 0,25 %
Temp. coefficient	5 ppm/°C
Max. current	10 mA
Max. power supply	50 V
Usual power supply	5 V

Conditions for use	
Temperature range	-25 ... 75°C
Vibration	10 g/30 ... 500 Hz

Part number	
ASL-6-06-05PA-HE	<b>B 261 209 578</b>
Offer drawing	<b>A 261 209 578</b>

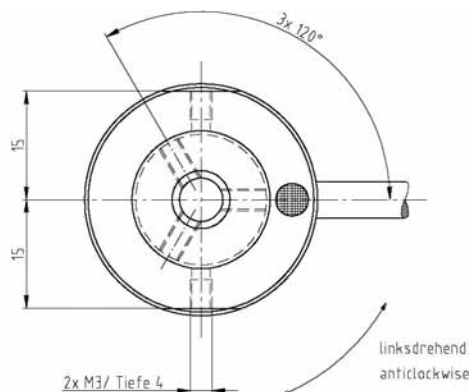
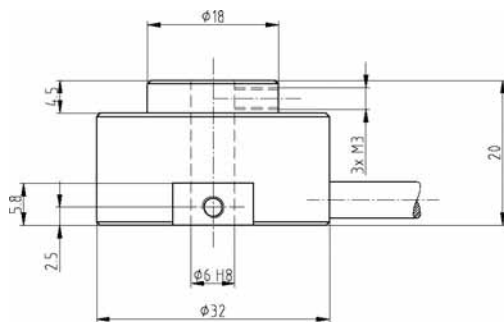

## Rotary Potentiometer RP 86

This sensor is designed to measure rotational movement, especially throttle positions. Each sensor is individually laser-calibrated.



Mechanical data	
Mounting	2 x M4
Length	160 ... 300 mm
Mech. range	< 86°
Max. rotation speed	120 x 1/min
Tightening torque	1,5 ... 2,5 Nm
Weight	60 g
Life expectancy	> 2 x 10 <sup>5</sup> rotations

Conditions for use	
Temperature range	-40 ... 130°C
Vibration	40 g/5 Hz ... 2 kHz

Electrical data	
Nominal resistance	2,5 kΩ
Resistance tolerance	20 %
Non-linearity	0,9 %
Repetitive accuracy	0,01 %
Temp. coefficient	< 5 ppm/°C
Max. power supply	42 V
Usual power supply	5 V

Connector	
Cable harness connector	<b>D 261 205 334</b>

Part number	
	<b>0 280 122 016</b>
Offer drawing	<b>A 280 121 252</b>

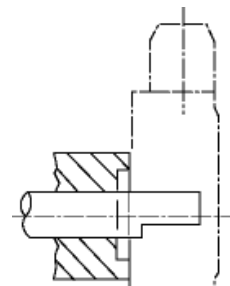
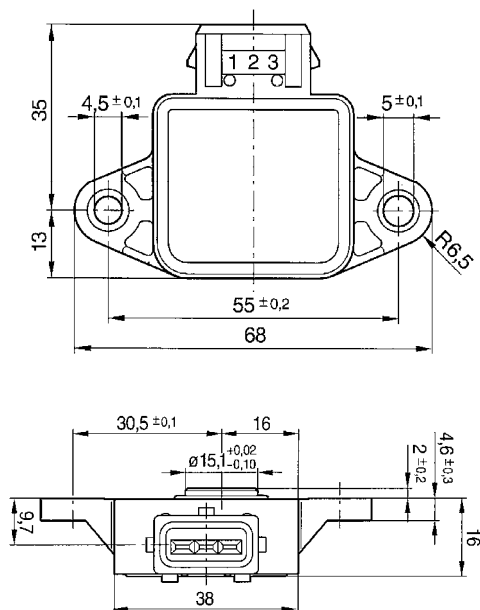

## Rotary Potentiometer RP 100

This sensor is designed to measure rotational movement, especially the throttle position e.g. very precisely and in a big range.

Picking up an internal resistant and collector ring a rotation angle can be converted into an angle proportional output voltage. The housing and the bearings are made of high temperature resistant plastic. The mounting plate is protected with a metal cover to ensure a good fixation.

The main benefit of this sensor is the combination of both high quality production part and military spec connection. Furthermore it has a good cost-performance ratio.



Application	
Application	0 ... 100°
Angle Between Intern Mechanical Stops	no stops
Operating Temperature Range	-40 ... 150 °C
Storage Temperature Range	0 ... 100 °C

Electrical data	
Power Supply Us	5 V
Maximal Power supply	42 V
total resistance	3+/-20% kΩ
Current Is	1 μA
max. allowable contact current	10 mA

Mechanical data	
Weight w/o Cable	32 g
Sealing / Protection Class	IP65
Fixation	M4x2
Lifetime	50x10 <sup>6</sup> Rotation
Max. Vibration	20g @ 5 ... 2000 Hz

Characteristic	
Max. rotation speed	120 min <sup>-1</sup>
Temp. Coeffiecient	5 ppm/°K

**Connectors and Cables**

Connector	ASL 6-06-05PN-HE
Connector Loom	ASL 0-06-05SC-HE
Pin 1	Us
Pin 2	Gnd
Pin 3	Sig
Pin 4	-
Pin 5	-
Pin 6	na
Sleeve	DR-25
Cable Size	AWG 18
Cable Length L	16-30 cm

**Application Hint**

The products of the RP series can be connected directly to most control units.

The sensor has no internal stops so it is endless pivotable.

Each mounting orientation is possible.

The sensor meets all EMV, EMC and ESD automotive standards.

Please find further application hints in the offer drawing (<http://www.bosch-motorsport.com>).

**Part number**

ASL 6-06-05PN-HE

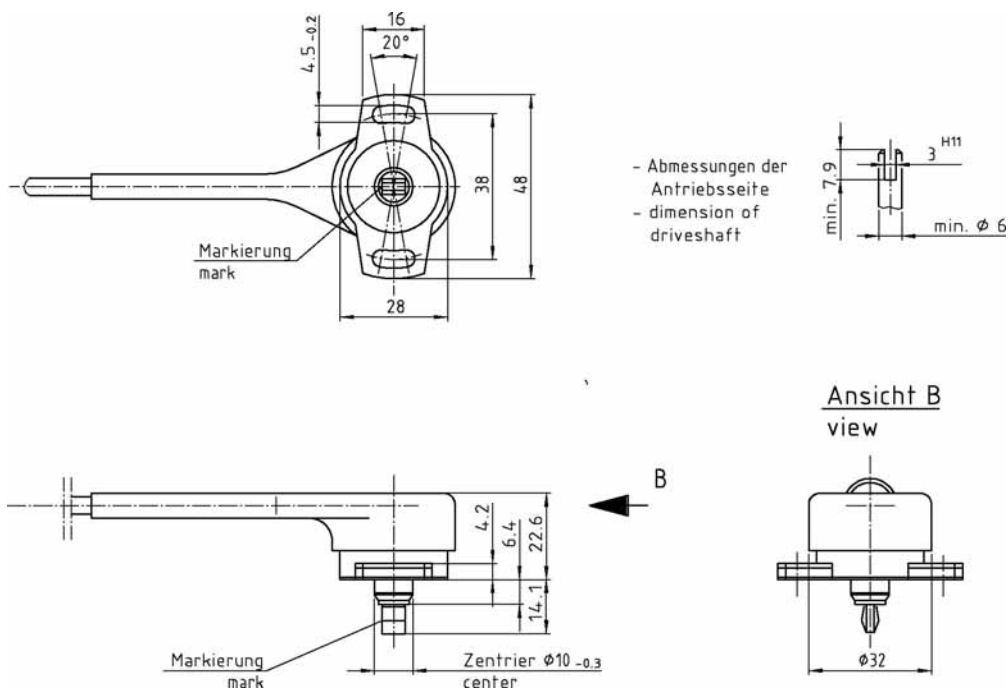
**B 261 209 117**

## Rotary Potentiometer RP 100 twin

The Rotary Potentiometer RP 100 twin is used in applications where redundant signals are necessary to ensure that the system runs failsafe. A typical field of application are electronic throttle control systems where angle movement is measured by the RP 100 twin.

The sensor is manufactured in a DR-25 sleeve. Various connector options are available.



Mechanical data	
Mounting	2 x M4
Length	160 ... 300 mm
Mech. range	$\pm 360^\circ$
Max. rotation speed	120 x 1/min
Tightening torque	0,5 Nm
Weight w/o cable	32 g
Lifetime	$> 50 \times 10^5$ rotations
Protection	IP 65

Conditions for use	
Temperature range	-40 ... 150°C
Vibration	20 g/5 Hz ... 2 kHz

Electrical data	
Nominal resistance	3 k $\Omega$
Resistance tolerance	20 %
Non-linearity	$\pm 1$ %
Repetitive accuracy	$\leq 0,01$ %
Temp. coefficient	$< 5$ ppm/°C
Max. power supply	42 V
Usual power supply	5 V

Part numbers	
<b>Anticlockwise</b>	
AS 6-07-35PN	<b>B 261 209 588</b>
Offer drawing	<b>A 261 209 588</b>
<b>Clockwise</b>	
AS 6-07-35PN	<b>B 261 209 592</b>
Offer drawing	<b>A 261 209 592</b>

# Rotary Potentiometer RP 130

This sensor is designed to measure rotational movement. Each sensor is individually laser-calibrated. It is manufactured in a DR-25 sleeve, various connector options are available.



Mechanical data	
Mounting	2 x M4
Length	160 ... 300 mm
Mech. range	360°
Max. rotation speed	120 x 1/min
Tightening torque	0,5 Nm
Weight	60 g
Lifetime	> 50 x 10 <sup>5</sup> rotations

Conditions for use	
Temperature range	-20 ... 150°C
Vibration	40 g/5 Hz ... 2 kHz

Electrical data	
Nominal resistance	3 kΩ
Resistance tolerance	20 %
Non-linearity	0,9 %
Repetitive accuracy	0,01 %
Temp. coefficient	< 5 ppm/°C
Max. power supply	42 V
Usual power supply	5 V

Part number	
ASL 6-06-05PA-HE	<b>B 261 209 128</b>
Offer drawing	<b>A 261 209 128</b>

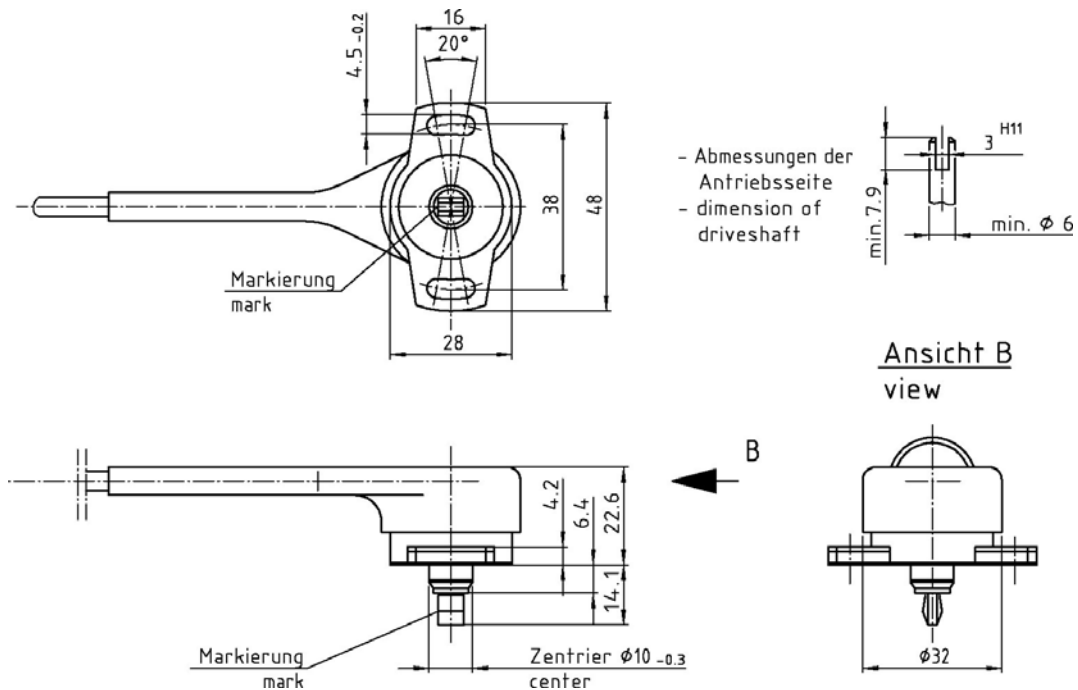

# Rotary Potentiometer RP 130-M

This sensor is designed to measure rotational movement. Each sensor is individually laser-calibrated. It is manufactured in a DR-25 sleeve, various connector options are available. Metal housing.



Mechanical data	
Mounting	2 x M4
Length	160 ... 300 mm
Mech. range	360°
Max. rotation speed	120 x 1/min
Tightening torque	0,5 Nm
Weight	60 g
Lifetime	> 50 x 10 <sup>5</sup> rotations

Conditions for use	
Temperature range	-55 ... 125°C
Vibration	40 g/5 Hz ... 2 kHz

Electrical data	
Nominal resistance	3 kΩ
Resistance tolerance	20 %
Non-linearity	0,9 %
Repetitive accuracy	0,01 %
Temp. coefficient	< 5 ppm/°C
Max. power supply	42 V
Usual power supply	5 V

Part number	
KPTA 6E6-4P-C-DN	<b>B 261 209 576</b>
Offer drawing	<b>A 261 209 576</b>

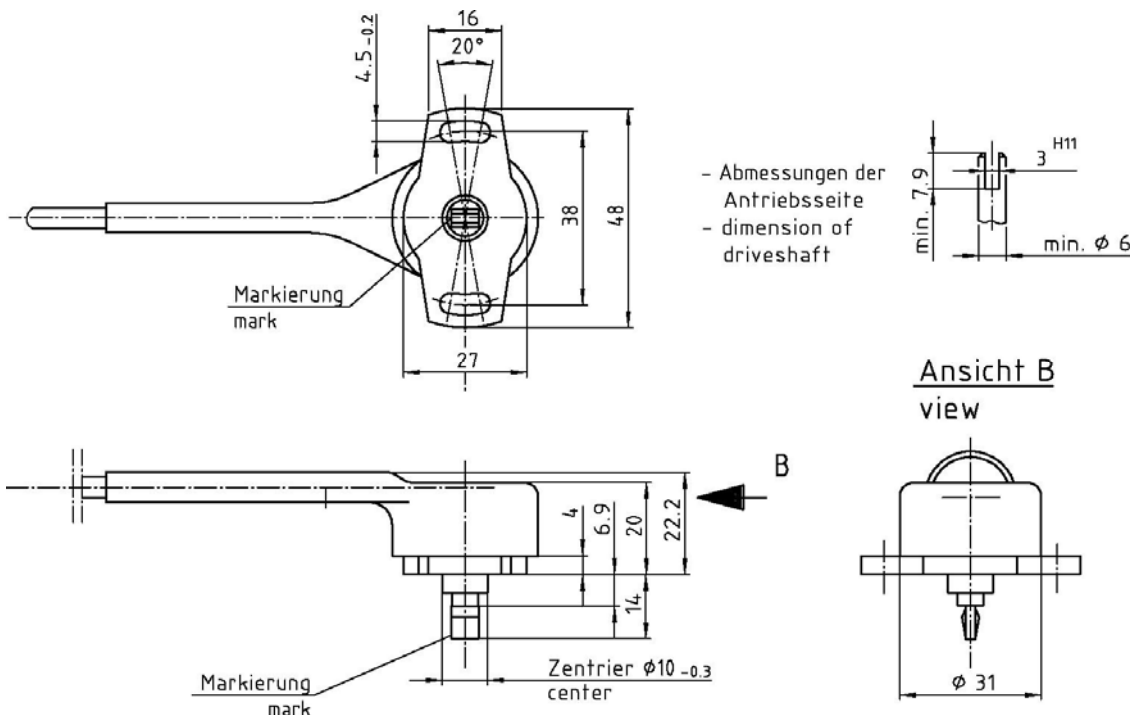



## Rotary Potentiometer RP 308

This sensor is designed to measure rotational movement, especially the throttle position e. g. very precisely and in a big range.

Picking up an internal resistant and collector ring a rotation angle can be converted into an angle proportional output voltage. The housing and the bearings are made of high temperature resistant plastic. The mounting plate is protected with a metal cover to ensure a good fixation.

The main benefit of this sensor is the combination of both high quality production part and military spec connection. Furthermore it has a good cost-performance ratio.



Application	
Application	0 ... 308 °
Angle between internal mechanical Stops	no stops
Operating Temperature Range	-40 ... 150 °C

Mechanical Data	
Weight w/o Cable	32 g
Fixation	M4x2
Lifetime	50 x 10 <sup>6</sup> Rotation
Max. Vibration	20 g @ 5 ... 2.000 Hz

Electrical Data	
Power Supply U <sub>s</sub>	5 V
Maximal Power supply	42 V
Total Resistance	5 kΩ +/-20 %
Current I <sub>s</sub>	1 μA
Max. allowable Contact Current	10 mA

Characteristic	
Max. Rotation Speed	120 min <sup>-1</sup>
Temp. Coefficient	5 ppm/°K

**Connectors and Cables**

Connector I	ASL 6-06-05PA-HE
Connector Loom I	ASL 0-06-05SA-HE
Pin 1	Us
Pin 2	Gnd
Pin 3	Sig
Pin 4	-
Pin 5	-
Pin 6	n. a.
Sleeve	DR-25
Cable Size	AWG 24
Cable Length L	16-30 cm

**Application Hint**

The products of the RP series can be connected directly to most control units.

The sensor has no internal stops so it is endless pivotable.

Each mounting orientation is possible.

The sensor meets all EMV, EMC and ESD automotive standards.

Please find further application hints in the offer drawing (<http://www.bosch-motorsport.com>).

**Part Number**

RP 308

**B 261 209 570**

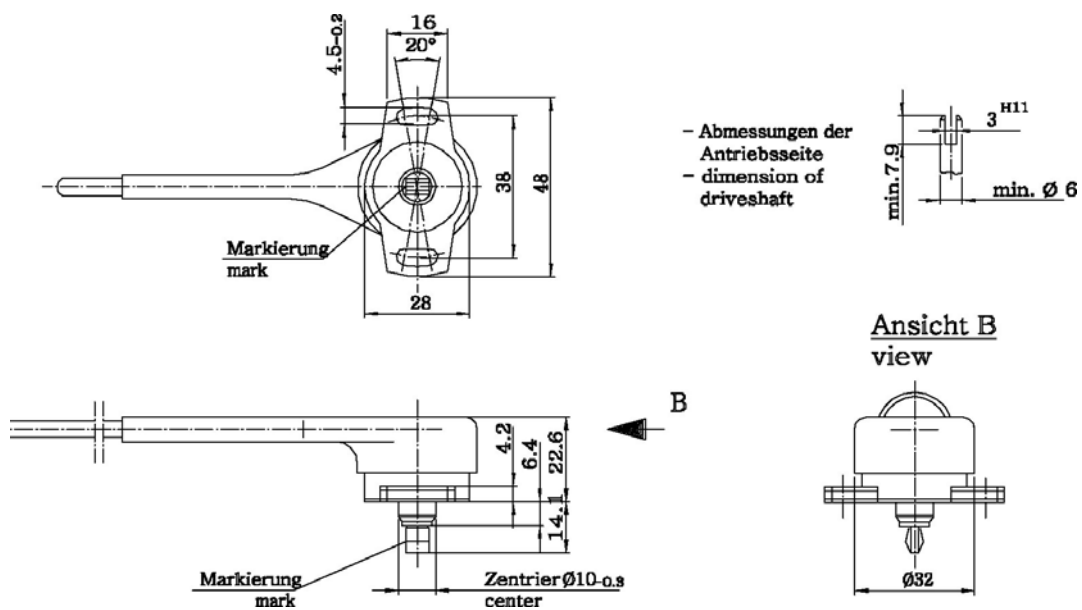

# Rotary Potentiometer RP 350-M

This sensor is designed to measure rotational movement. Each sensor is individually laser-calibrated. It is manufactured in a DR-25 sleeve, various connector options are available. Metal housing.



Mechanical data	
Mounting	2 x M4
Length	160 ... 300 mm
Mech. range	360°
Max. rotation speed	120 x 1/min
Tightening torque	0,5 Nm
Weight	60 g
Lifetime	> 50 x 10 <sup>5</sup> rotations

Electrical data	
Nominal resistance	6 kΩ
Resistance tolerance	20 %
Non-linearity	0,9 %
Repetitive accuracy	0,01 %
Temp. coefficient	< 5 ppm/°C
Max. power supply	42 V
Usual power supply	5 V

Conditions for use	
Temperature range	-55 ... 125°C
Vibration	40 g/5 Hz ... 2 kHz

Part number	
ASL 6-06-05PA-HE	<b>B 261 209 577</b>
Offer drawing	<b>A 261 209 577</b>

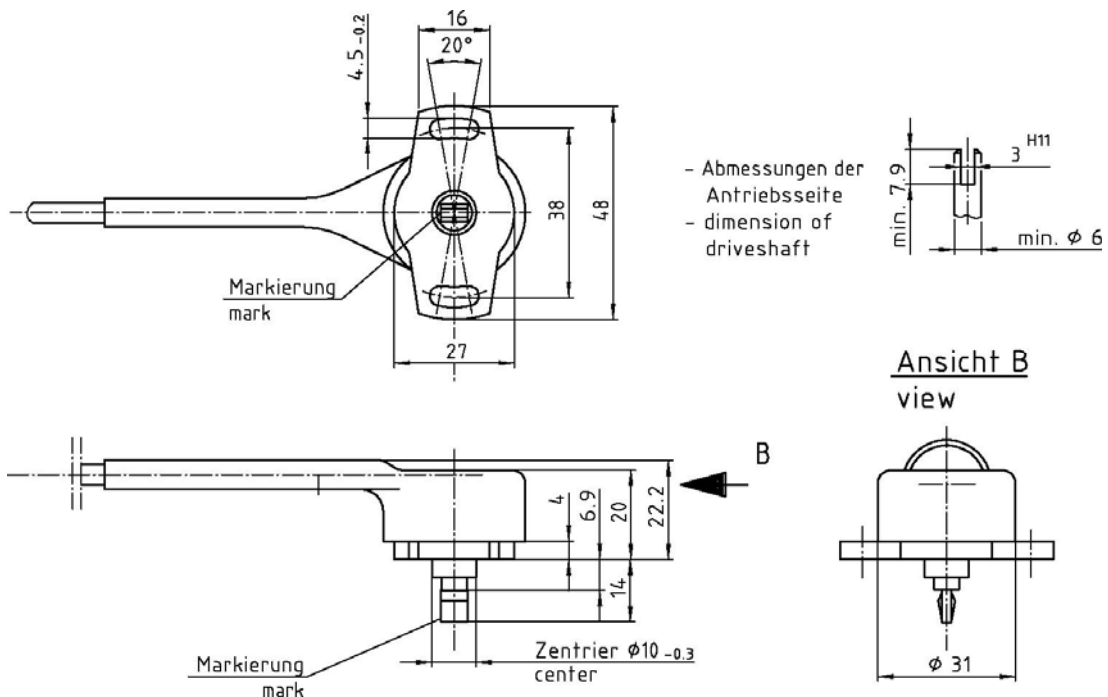

# Linear Potentiometers

## Linear Potentiometer LP 10

This sensor is designed to measure stabilizer movement. It is manufactured in a DR-25 sleeve. Various connector options are available.



Mechanical data	
Mounting	2 x M3
Cable length	150 ... 1000 mm
Weight	70 g
Conditions for use	
Temperature range	-25 ... 75°C

Electrical data	
Nominal resistance	1 k $\Omega$ $\pm$ 20 %
Max. current	1 mA
Non-linearity	1 %
Usual power supply	5 V
Power consumption	0,3 W

Part number	
KPSE 6E8-33P-DN	<b>B 261 209 535</b>
Offer drawing	<b>A 261 209 535</b>

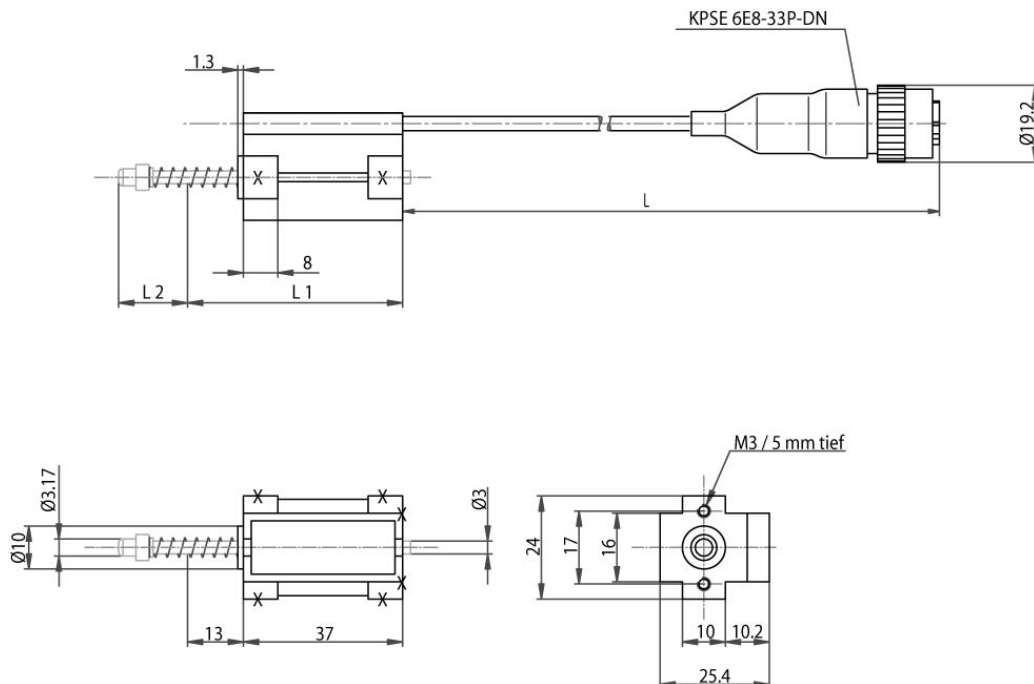

## Linear Potentiometer LP 25 twin

The Linear Potentiometer LP 25 twin is used in applications where redundant signals are necessary to ensure that the system runs failsafe. A typical field of application are electronic throttle control systems. Various connector options are available.



Mechanical data	
Possible mech. range [L2]	50 mm
Min. length [L1]	120 mm
Cable length [L]	150 ... 1000 mm
Mounting hole	Ø 3 mm
Protection	IP 66
Max. shaft velocity	10 m/sec
Weight	approx. 50 g

Conditions for use	
Temperature range	-30 ... 100°C

Electrical data	
Nominal resistance [25 ... 50 mm]	1 kΩ
Non-linearity	0,25 %
Usual power supply	5 V
Max. power supply	45 V

Part number	
AS 6-07-35PN	<b>B 261 209 858</b>
Offer drawing	<b>A 261 209 858</b>

## Linear Potentiometer LP 50

This sensor is designed to measure gear position, throttle position or suspension movement. It is manufactured in a DR-25 sleeve, various connector options are available.



Mechanical data	
Possible mech. range [L2]	50 mm
Min. length [L1]	172 mm
Cable length [L]	150 ... 1000 mm
Mounting	2 x M5
Sealing	O-ring shaft seal
Tightening torque	10 Nm
Max. shaft velocity	1000 mm/sec
Weight [25 ... 150 mm]	90 ... 150 g

Conditions for use	
Temperature range	-20 ... 85°C
Vibration	10 g/5 ... 500 Hz
Shock	30 g/11 ms

Electrical data	
Nominal resistance [25 ... 150 mm]	2 kΩ
Max. current	< 1 mA
Non-linearity	0,25 %
Usual power supply	5 V
Max. power supply	42 V

Part number	
KPTA 6E6-4P-C-DN	<b>B 261 209 136</b>
Offer drawing	<b>A 261 209 136</b>

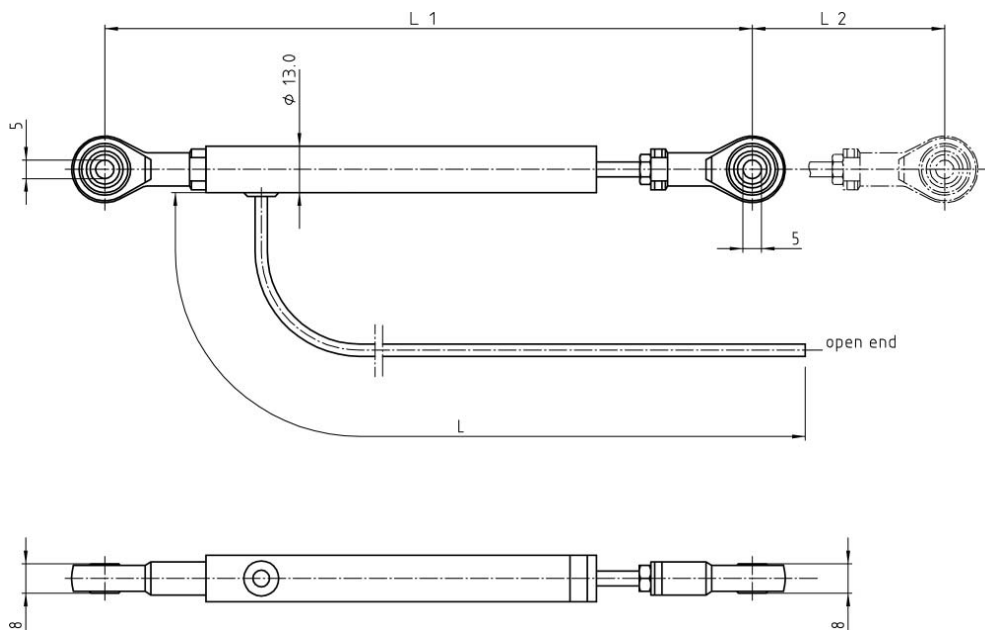

## Linear Potentiometer LP 50 twin

The Linear Potentiometer LP 50 twin is used in applications where redundant signals are necessary to ensure that the system runs failsafe. A typical field of application are electronic throttle control systems. Various connector options are available.



Mechanical data	
Possible mech. range [L2]	50 mm
Min. length [L1]	120 mm
Cable length [L]	150 ... 1000 mm
Mounting hole	∅ 3 mm
Protection	IP 66
Max. shaft velocity	10 mm/sec
Weight	approx. 60 g

Conditions for use	
Temperature range	-30 ... 100°C

Electrical data	
Nominal resistance [25 ... 50 mm]	2 kΩ
Non-linearity	0,25 %
Usual power supply	5 V
Max. power supply	45 V

Part numbers	
AS 6-07-35N	<b>B 261 209 859</b>
Offer drawing	<b>A 261 209 859</b>

## Linear Potentiometer LP 75

This sensor is designed to measure gear position, throttle position or suspension movement. It is manufactured in a DR-25 sleeve, various connector options are available.



Mechanical data	
Possible mech. range [L2]	75 mm
Min. length [L1]	197 mm
Cable length [L]	150 ... 1000 mm
Mounting	2 x M5
Sealing	O-ring shaft seal
Tightening torque	10 Nm
Max. shaft velocity	1000 mm/s
Weight [25 ... 150 mm]	90 ... 150 g

Electrical data	
Nominal resistance [25 ... 150 mm]	3 k $\Omega$
Max. current	< 1 mA
Non-linearity	0,15 %
Usual power supply	5 V
Max. power supply	42 V

Part number	
KPSE 6E8-33P-DN	<b>B 261 209 530</b>

Conditions for use	
Temperature range	-20 ... 85 °C
Vibration	10 g/5 ... 500 Hz
Shock	30 g/11 ms

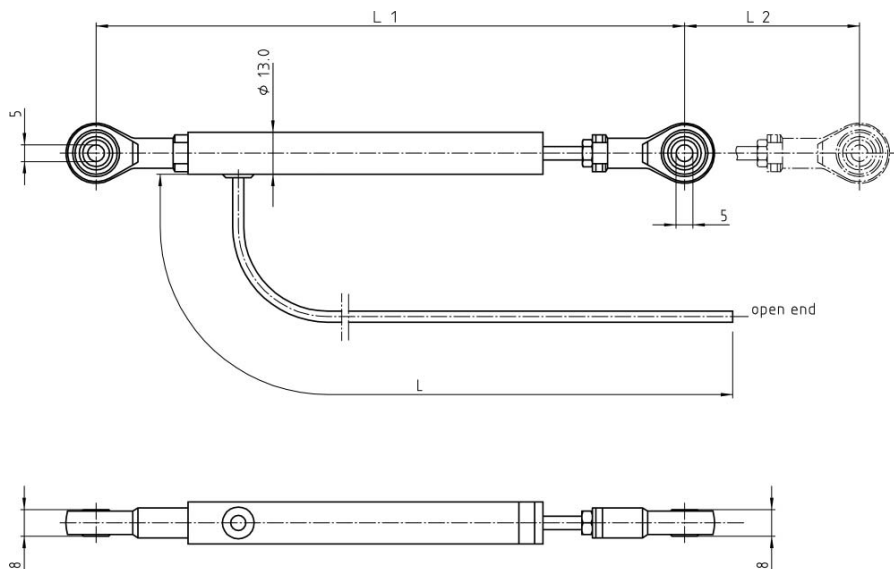



## Linear Potentiometer LP 75F

This sensor is designed to measure gear position, throttle position or suspension movement. It is manufactured in a DR-25 sleeve, various connector options are available. Optionally a protective sleeve for the telescopic shaft can be ordered.



Mechanical data	
Cable length L	150 ... 1000 mm
Min. length L1	220 mm
Possible mech. range L2	79 mm
Mounting	2 x M5
Sealing	O-ring shaft seal
Max. shaft velocity	10 m/sec
Weight	52 g

Conditions for use	
Temperature range	-30 ... 100°C

Electrical data	
Nominal resistance	3 kΩ
Max. current	< 1 mA
Non-linearity	0,15 %
Usual power supply	5 V
Max. power supply	47 V

Part number	
KPSE 6E8-33P-DN	<b>B 261 209 852</b>
Offer drawing	<b>A 261 209 852</b>

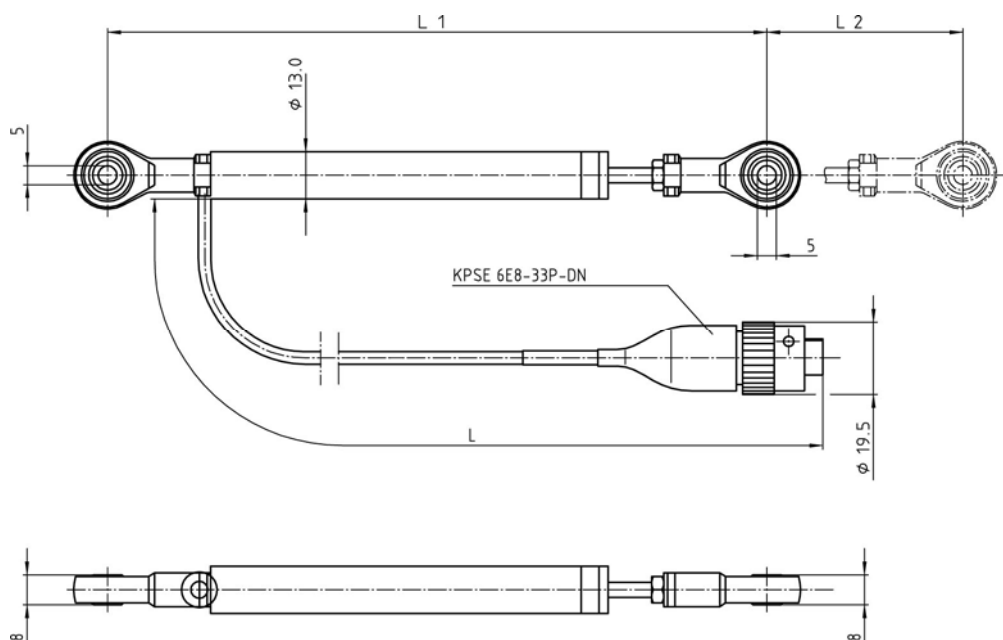

## Linear Potentiometer LP 100

This sensor is designed to measure gear position, throttle position or suspension movement. It is manufactured in a DR-25 sleeve, various connector options are available.



Mechanical data	
Possible mech. range [L2]	100 mm
Min. length [L1]	220 mm
Cable length [L]	150 ... 1000 mm
Mounting	2 x M5
Tightening torque	10 Nm
Sealing	O-ring shaft seal
Max. shaft velocity	1000 mm/s
Weight [25 ... 150 mm]	90 ... 150 g

Conditions for use	
Temperature range	-20 ... 85 °C
Vibration	10 g/5 ... 500 Hz
Shock	30 g/11 ms

Electrical data	
Nominal resistance [25 ... 150 mm]	4 kΩ
Max. current	< 1 mA
Non-linearity	0,15 %
Usual power supply	5 V
Max. power supply	42 V

Part number	
KPSE 6E8-33P-DN	<b>B 261 209 134</b>
KPTA 6E6-4P-C-DN	<b>B 261 209 137</b>

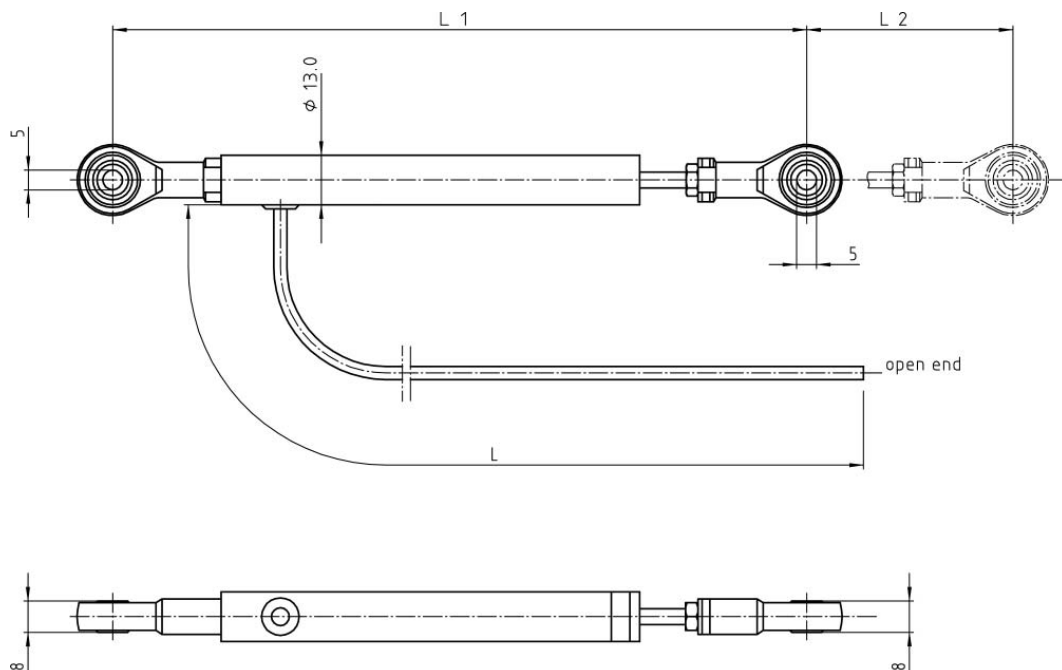

## Linear Potentiometer LP 100F

This sensor is designed to measure gear position, throttle position or suspension movement. It is manufactured in a DR-25 sleeve, various connector options are available. Optionally a protective sleeve for the telescopic shaft can be ordered.



Mechanical data	
Cable length L	150 ... 1000 mm
Min. length L1	244 mm
Possible mech. range L2	104 mm
Mounting	2 x M5
Sealing	O-ring shaft seal
Max. shaft velocity	10 m/sec
Weight	62 g

Conditions for use	
Temperature range	-30 ... 100°C

Electrical data	
Nominal resistance	4 kΩ
Max. current	< 1 mA
Non-linearity	0,15 %
Usual power supply	5 V
Max. power supply	74 V

Part number	
KPSE 6E8-33P-DN	<b>B 261 209 853</b>
Offer drawing	<b>A 261 209 853</b>

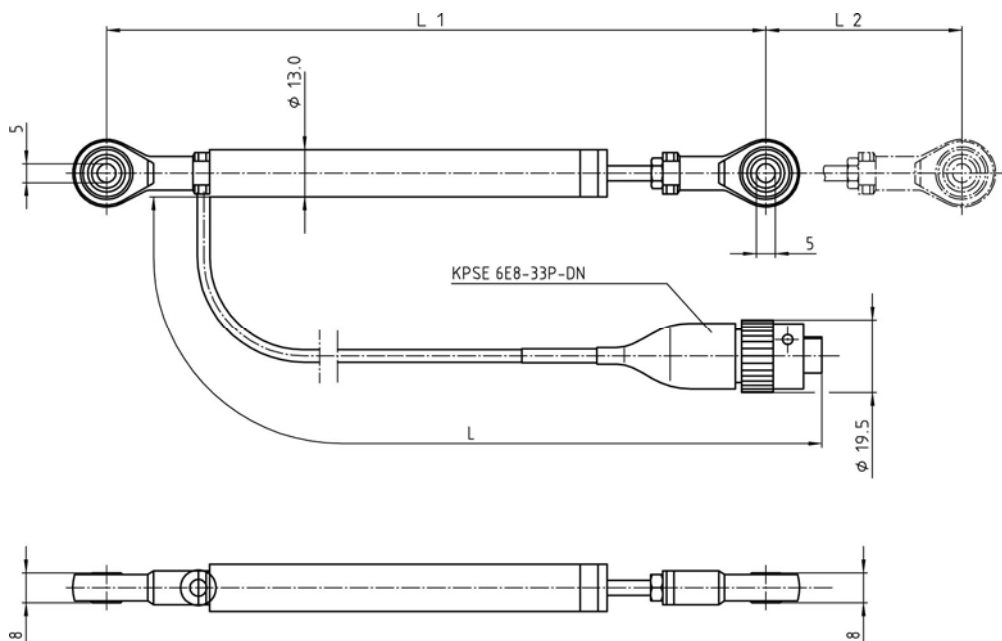

## Linear Potentiometer LP 150

This sensor is designed to measure gear position, throttle position or suspension movement. It is manufactured in a DR-25 sleeve, various connector options are available.



Mechanical data	
Possible mech. range [L2]	150 mm
Min. length [L1]	278 mm
Cable length [L]	150 ... 1000 mm
Mounting	2 x M5
Sealing	O-ring shaft seal
Tightening torque	10 Nm
Max. shaft velocity	1000 mm/sec
Weight [25 ... 150 mm]	90 ... 150 g

Conditions for use	
Temperature range	-20 ... 85°C
Vibration	10 g/5 ... 500 Hz
Shock	30 g/11 ms

Electrical data	
Nominal resistance [25 ... 150 mm]	6 kΩ
Max. current	< 1 mA
Non-linearity	0,15 %
Usual power supply	5 V
Max. power supply	42 V

Part numbers	
KPTA 6E6-4P-C-DN	<b>B 261 209 138</b>
Offer drawing	<b>A 261 209 138</b>
AS 6-06-05PA-HE	<b>B 261 209 534</b>
Offer drawing	<b>A 261 209 534</b>

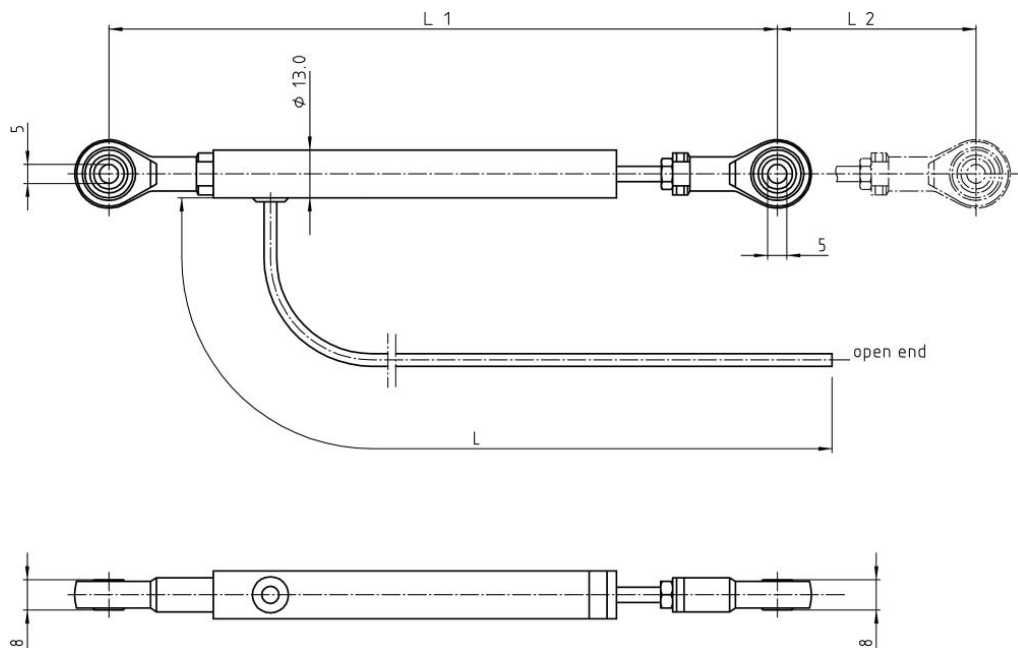

# Wire Potentiometers

## Wire Potentiometer WP 35

Wire sensors are suitable for measuring linear and non-linear motions. The compact style allows flexible and easy installation. Due to the small size, precise measurement is possible even in difficult applications.



Various connector options available.

Mechanical data	
Possible mech. range	38,1 mm
Mounting	2 x 2-56 THD
Cable length	150 ... 450 mm
Tightening torque	1,5 ... 2,5 Nm
Weight	15 g
Life expectancy	50 x 10 <sup>6</sup> rotations
Protection	IP 54
Dimensions	19 x 19 x 9,7 mm

Conditions for use	
Temperature range	-65 ... 125°C
Max. cable acceleration	15 g
Max. cable tension	1,7 N
Shock	100 g for 6 ms
Vibration	10 Hz ... 2 kHz at 15 g

Accessories	
Holder	

Electrical data	
Nominal resistance	5,0 kΩ ± 10 %
Non-linearity	± 0,5 %
Usual power supply	5 V
Max. power supply	50 V

Part number	
ASL 6-06-05PA-HE	<b>B 261 209 541</b>
Offer drawing	A 261 209 541
Holder	<b>B 261 209 864</b>

### ! Caution !

#### User, please observe the following:

- Ensure electrical connections are performed according to the enclosed Position Transducer User's Guide.
- Do not allow the cable to snap back (freely retract). This will cause damage and void the warranty. Tension must be maintained on the cable at all times.

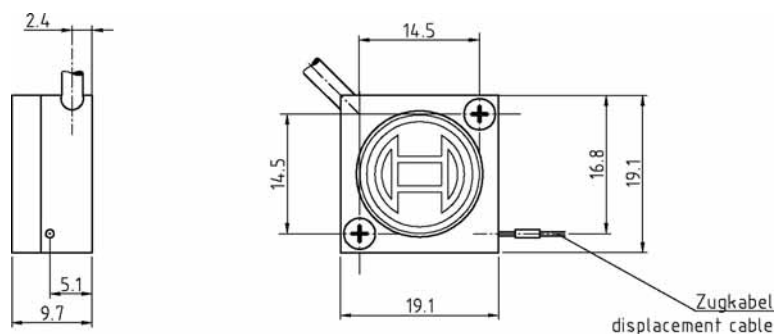

## Wire Potentiometer WP 50

Wire sensors are suitable for measuring linear and non-linear motions. The compact style allows flexible and easy installation. Due to the small size, precise measurement is possible even in difficult applications.

Various connector options available. We offer repair service for this product.



Mechanical data	
Possible mech. range	50,8 mm
Mounting	2 x 2-56 THD
Cable length	150 ... 450 mm
Tightening torque	1,5 ... 2,5 Nm
Weight	28 g
Life expectancy	50 x 10 <sup>6</sup> rotations
Protection	IP 54
Dimensions	24,4 x 11,4 mm

Conditions for use	
Temperature range	-65 ... 125°C
Max. cable acceleration	40 g
Max. cable tension	3,3 N
Shock	100 g for 6 ms
Vibration	10 Hz ... 2 kHz at 15 g

Accessories	
Holder	

Electrical data	
Nominal resistance	5,0 kΩ ± 10 %
Non-linearity	± 0,5 %
Usual power supply	5 V
Max. power supply	50 V

Part number	
ASL 6-06-05PA-HE	<b>B 261 209 542</b>
Offer drawing	<b>A 261 209 542</b>
Holder	<b>B 261 209 864</b>

### ! Caution !

#### User, please observe the following:

- Ensure electrical connections are performed according to the enclosed Position Transducer User's Guide.
- Do not allow the cable to snap back (freely retract). This will cause damage and void the warranty. Tension must be maintained on the cable at all times.

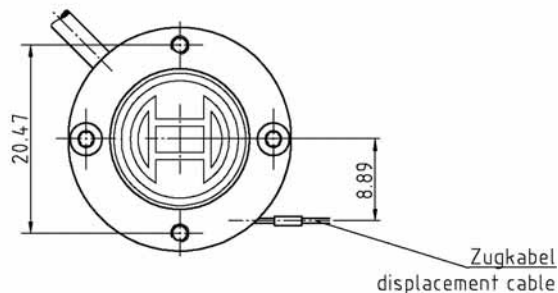
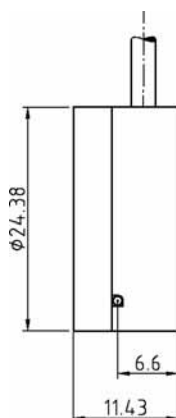

## Wire Potentiometer WP 75

Wire sensors are suitable for measuring linear and non-linear motions. The compact style allows flexible and easy installation. Due to the small size, precise measurement is possible even in difficult applications.

Various connector options available. We offer repair service for this product.



Mechanical data	
Possible mech. range	76,2 mm
Mounting	2 x 2-56 THD
Cable length	150 ... 450 mm
Tightening torque	1,5 ... 2,5 Nm
Weight	28 g
Life expectancy	50 x 10 <sup>6</sup> rotations
Protection	IP 54
Dimensions	32,5 x 11,4 mm

Conditions for use	
Temperature range	-65 ... 125°C
Max. cable acceleration	17 g
Max. cable tension	3,3 N
Shock	100 g for 6 ms
Vibration	10 Hz ... 2 kHz at 15 g

Accessories	
Holder	

Electrical data	
Nominal resistance	5,0 kΩ ± 10 %
Non-linearity	± 0,5 %
Usual power supply	5 V
Max. power supply	38 V

Part numbers	
ASL 6-06-05PA-HE	B 261 209 543
Offer drawing	A 261 209 543
Holder	B 261 209 865

### ! Caution !

#### User, please observe the following:

- Ensure electrical connections are performed according to the enclosed Position Transducer User's Guide.
- Do not allow the cable to snap back (freely retract). This will cause damage and void the warranty. Tension must be maintained on the cable at all times.

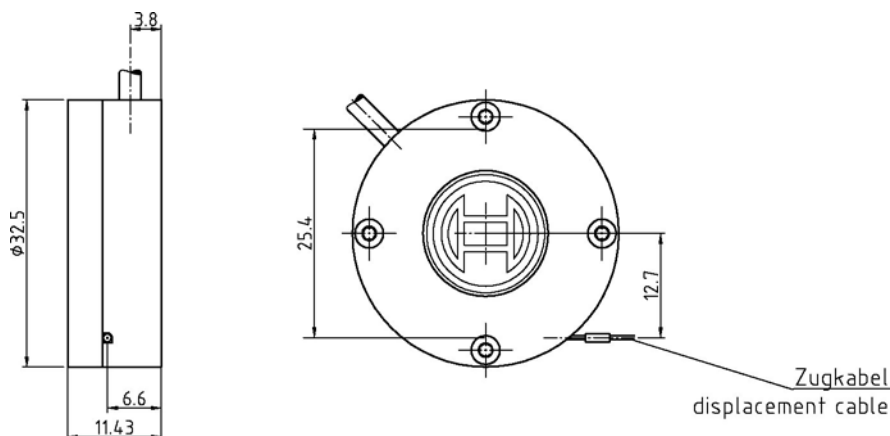

## Wire Potentiometer WP 100

Wire sensors are suitable for measuring linear and non-linear motions. The compact style allows flexible and easy installation. Due to the small size, precise measurement is possible even in difficult applications.

Various connector options available. We offer repair service for this product.



Mechanical data	
Possible mech. range	101,6 mm
Mounting	2 x 2-56 THD
Cable length	150 ... 450 mm
Tightening torque	1,5 ... 2,5 Nm
Weight	57 g
Life expectancy	50 x 10 <sup>6</sup> rotations
Protection	IP 54
Dimensions	43,3 x 12,5 mm

Conditions for use	
Temperature range	-65 ... 125°C
Max. cable acceleration	9 g
Max. cable tension	2,8 N
Shock	100 g for 6 ms
Vibration	10 Hz ... 2 kHz at 15 g

Electrical data	
Nominal resistance	5,0 kΩ ± 10 %
Non-linearity	± 0,5 %
Usual power supply	5 V
Max. power supply	38 V

Part number	
KPTA 6E6-4P-C-DN	<b>B 261 209 863</b>
Offer drawing	<b>A 261 209 863</b>
Holder	<b>B 261 209 866</b>

### ! Caution !

#### User, please observe the following:

- Ensure electrical connections are performed according to the enclosed Position Transducer User's Guide.
- Do not allow the cable to snap back (freely retract). This will cause damage and void the warranty. Tension must be maintained on the cable at all times.

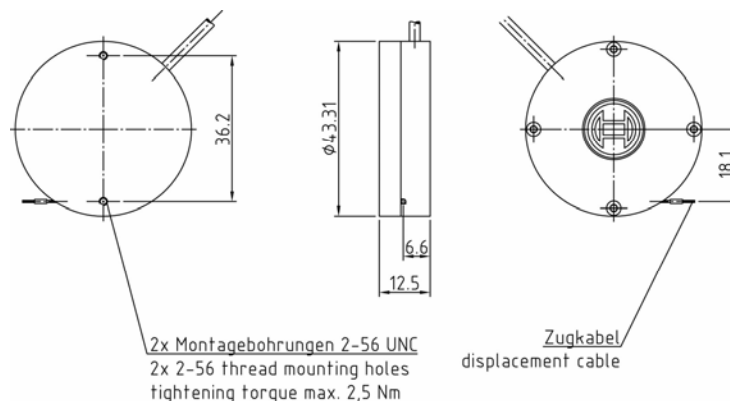



## Wire Potentiometer WP 120

Wire sensors are suitable for measuring linear and non-linear motions. The compact style allows flexible and easy installation. Due to the small size, precise measurement is possible even in difficult applications.

Manufactured in a DR-25 sleeve, various connector options available.



Mechanical data	
Possible mech. range	120 mm
Mounting	2 x M3
Cable length	150 ... 1000 mm
Tightening torque	1,5 ... 2,5 Nm
Weight	90 g
Life expectancy	1 x 10 <sup>6</sup> rotations

Conditions for use	
Temperature range	-15 ... 60°C
Max. moving speed	10 m/s

Electrical data	
Nominal resistance	1,0 kΩ
Non-linearity	± 1 %
Usual power supply	5 V
Max. power supply	25 V

Part number	
<b>120 mm</b>	
KPTA 6E6-4P-C-DN	<b>B 261 209 536</b>
Offer drawing	<b>A 261 209 536</b>
<b>96 mm</b>	on request

### ! Caution !

#### User, please observe the following:

- Ensure electrical connections are performed according to the enclosed Position Transducer User's Guide.
- Do not allow the cable to snap back (freely retract). This will cause damage and void the warranty. Tension must be maintained on the cable at all times.

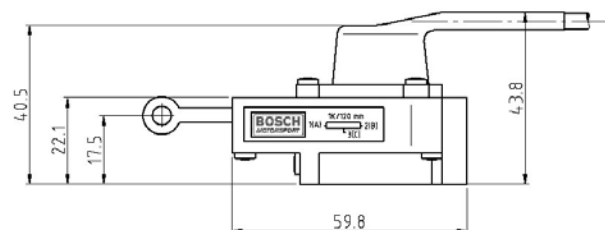
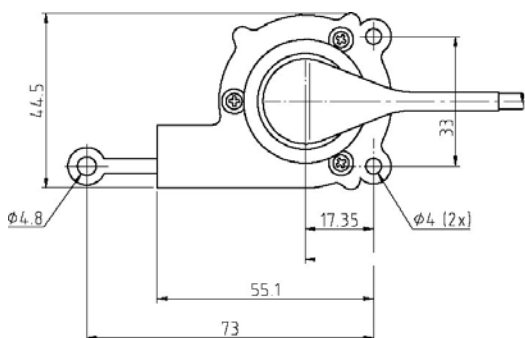

## Wire Potentiometer WP 125

Wire sensors are suitable for measuring linear and non-linear motions. The compact style allows flexible and easy installation. Due to the small size, precise measurement is possible even in difficult applications.

Various connector options available. We offer repair service for this product.



Mechanical data	
Possible mech. range	127,5 mm
Mounting	2 x 2-56 THD
Cable length	150 ... 450 mm
Tightening torque	1,5 ... 2,5 Nm
Weight	85 g
Life expectancy	50 x 10 <sup>6</sup> rotations
Protection	IP 54
Dimensions	50,5 x 13,2 mm

Conditions for use	
Temperature range	-65 ... 125°C
Max. cable acceleration	8 g
Max. cable tension	2,5 N
Shock	100 g for 6 ms
Vibration	10 Hz ... 2 kHz at 15 g

Accessories	
Holder	

Electrical data	
Nominal resistance	5,0 kΩ ± 10 %
Non-linearity	± 0,5 %
Usual power supply	5 V
Max. power supply	38 V

Part number	
ASL 6-06-05PA-HE	<b>B 261 209 545</b>
Offer drawing	<b>A 261 209 545</b>
Holder	<b>B 261 209 866</b>

### ! Caution !

#### User, please observe the following:

- Ensure electrical connections are performed according to the enclosed Position Transducer User's Guide.
- Do not allow the cable to snap back (freely retract). This will cause damage and void the warranty. Tension must be maintained on the cable at all times.

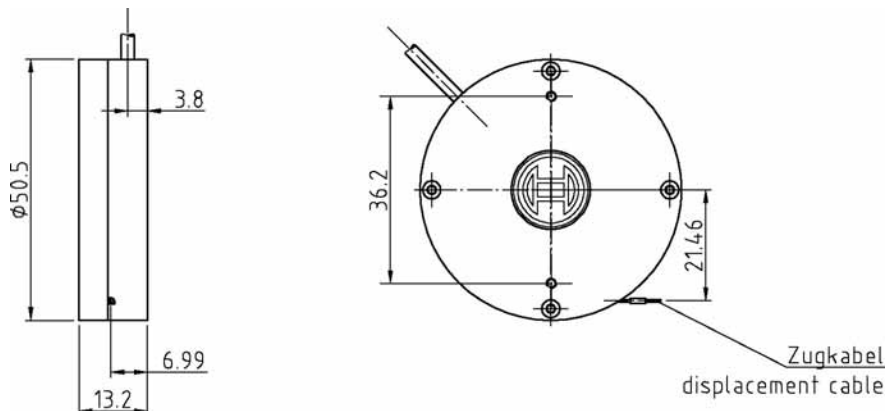

# Acceleration Sensor

## Accelerometer AM 600

These accelerometers are available to measure up to three axes in a single, robust package. With reference to its fitting position, longitudinal, transversal and horizontal acceleration up to 4,5 g can be measured.

Manufactured in DR-25 sleeve; various connector options available.



Mechanical data	
Weight 2 axes	30 g
3 axes	50 g
Length	150 ... 1000 mm
Measuring range	± 4,5 g
Overload	± 600 g
Dimensions	
<b>2 axes</b>	24 x 27 x 13,5 mm
<b>3 axes</b>	24 x 27 x 29,8 mm
Fixing	2 x M3
Tightening torque	2 Nm

Conditions for use	
Temperature range	-40 ... 85°C

Characteristic	
Offset x, y, z	2,5 V at 0 g
Sensitivity x, y, z	440 mV/g

Electrical data	
Supply voltage	5 V DC
Max. supply voltage	6 V DC
Signal output	2,5 V = 0 g; 440 mV/g
Supply current	7 mA
Max. current	12 mA
Tolerance of sensitivity	± 3 %
Non-linearity of sensitivity	± 2 %

Connector	
Cable harness connector	ASL 6-06-05PA-HE

Part numbers	
<b>2 axes</b>	<b>B 261 209 311</b>
Offer drawing	A 261 209 311
<b>3 axes</b>	<b>B 261 209 313</b>
Offer drawing	A 261 209 313

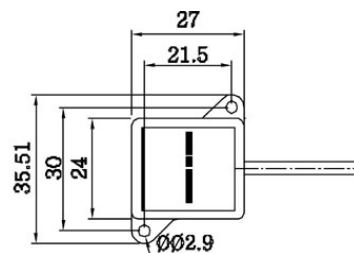
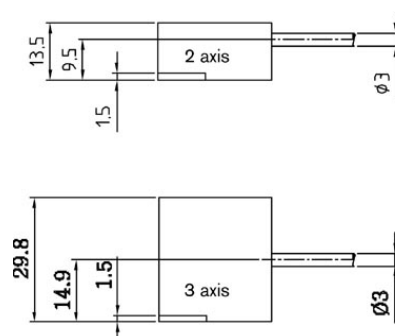

# Gear Shift Sensors

## Gear Shift Sensor GSS

This sensor is specially designed for precision gear shift force measurement. It can be integrated into the gear shift lever of a sequential gear box. It is manufactured in a DR-25 sleeve, various connector options are available.



Mechanical data	
Weight	90 g
Max. deviation	$\pm 10^\circ$
Fixing	2 x M10 x 1
Tightening torque	16 Nm
Dimensions	22 x 22 x 50 mm
Mech. Range	programmable up to 150 N

Conditions for use	
Temperature range	0 ... 80°C
Vibration	80 g/5 Hz ... 2 kHz

Characteristic	
Individual characteristic will be delivered with each sensor.	

Electrical data	
Supply voltage	10 V
Input current	< 1 mA
Signal output	1 ... 4 V $\pm$ 0,5 V
Zero output	4 V $\pm$ 0,3 V

Part numbers	
KPSE 6E8-33P-DN	B 261 209 222
Offer drawing	A 261 209 222
KPTA 6E6-4P-C-DN	B 261 209 224
Offer drawing	A 261 209 224
AS-6-06-05PC-HE	B 261 209 225
Offer drawing	A 261 209 225

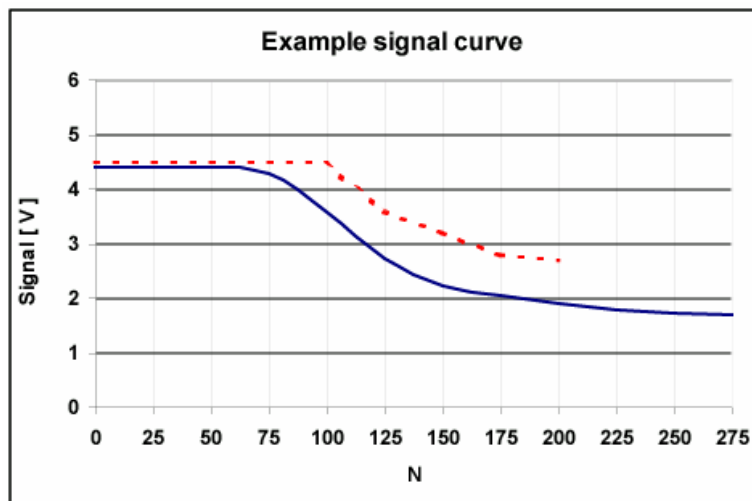

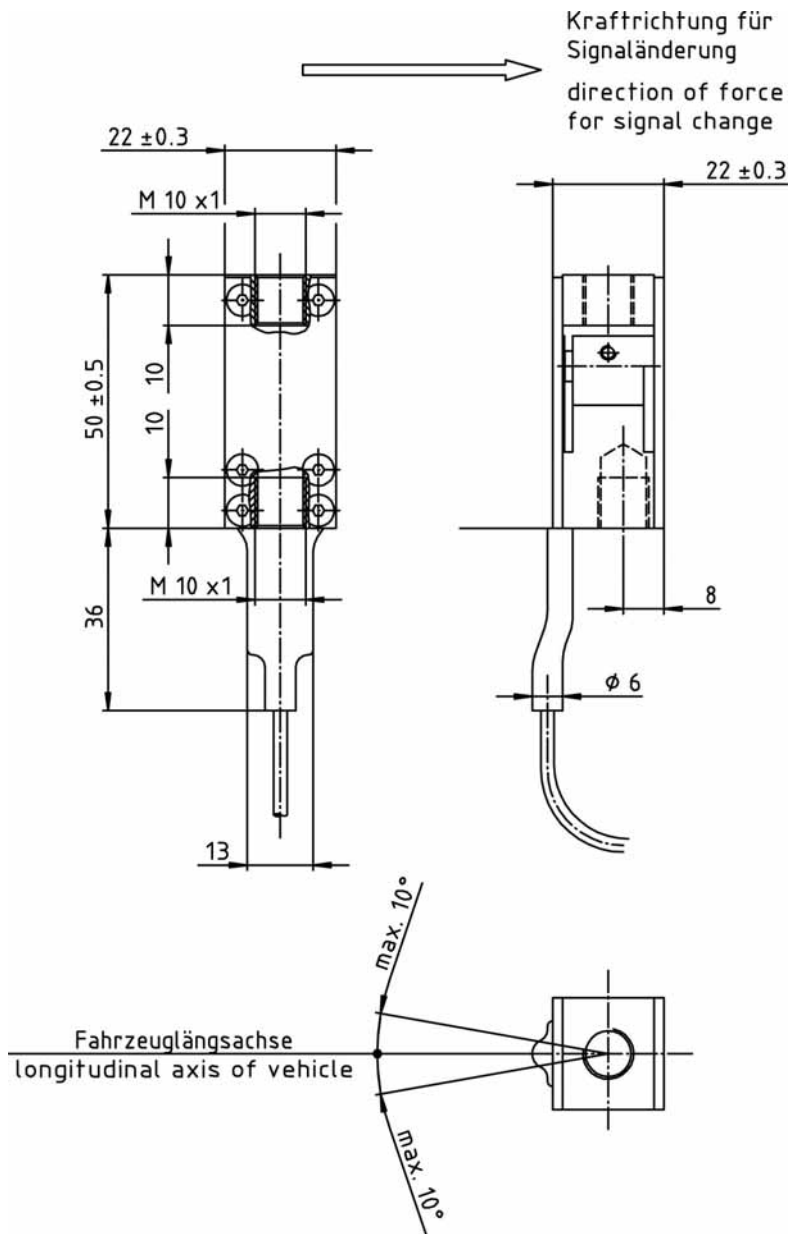

## Gear Shift Sensor GSS-2

This sensor is specially designed for precision gear shift force measurement. It can be integrated into the gear shift lever of a sequential gear box. It is manufactured in a DR-25 sleeve, various connector options are available.



Mechanical data	
Weight	90 g
Max. deviation	$\pm 10^\circ$
Fixing	2 x M10 x 1
Tightening torque	16 Nm
Dimensions	65 x 16 x 16 mm
Mech. range	programmable up to 450 N
Fmax	800 N
Mech. load limit	1800 N

Electrical data	
Supply voltage	12 V
Signal output	0,5 ... 4,5 V
Zero output	2,5 V

Conditions for use	
Temperature range	0 ... 80°C
Vibration	80 g/5 Hz ... 2 kHz

Characteristic
Individual characteristic will be delivered with each sensor.

Part number	
ASL-6-06-05PC-HE	<b>B 261 209 227</b>
Offer drawing	<b>A 261 209 227</b>

Force [N]	Voltage [V]
450	4,673
360	4,225
270	3,797
180	3,397
90	2,941
0	2,538
-90	2,141
-180	1,672
-270	1,255
-360	0,820
-450	0,402

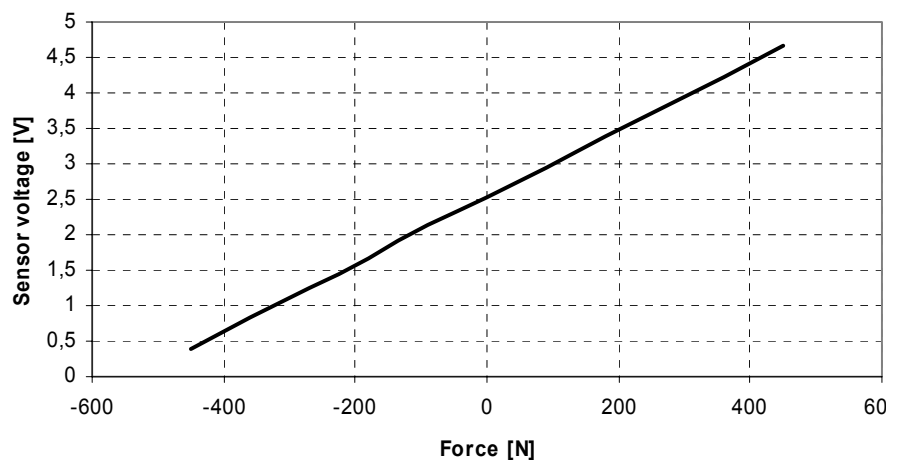

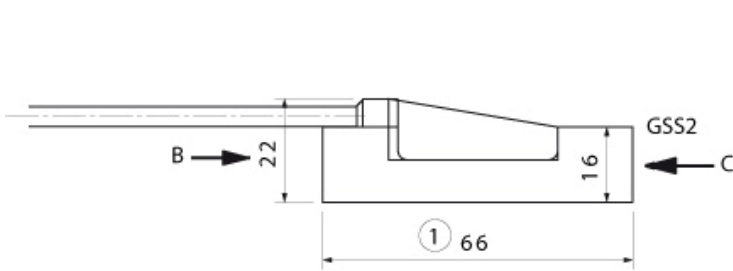

(Spannungsanstieg)  
(Increasing Voltage)

Kraftrichtung für Signaländerung  
Direction of signal altering force

(Spannungsabfall)  
(Decreasing Voltage)

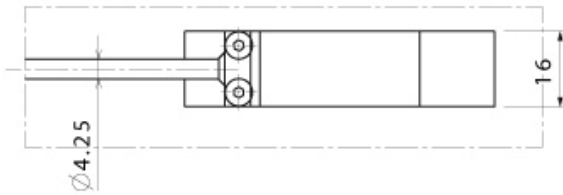

Ansicht B  
view

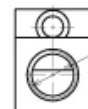
 M10 x 1  
Gewindetiefe  
thread length 11,7mm  
max. Anzugsmoment  
max. fastening torque 22 Nm

Ansicht C  
view

 M10 x 1  
Gewindetiefe  
thread length 11,7mm  
max. Anzugsmoment  
max. fastening torque 22 Nm

# Ride Height System

## Ride Height System RHS

This infrared sensor is designed to measure chassis adjust like vehicle ride height, pitch and roll. The sensor is available in a DR-25 sleeve with various connector options on request.



Mechanical data	
Weight	105 g
Measuring range	60 ... 140 mm
Dimensions	75 x 33 x 18 mm
Housing	plastic, fibreglass
Protection class	IP 67

Conditions for use	
Temperature range	-10 ... 60°C

Characteristic	
Light source	IR
Max. allowed ambient light	< 10000 lux
Wave length	660 nm

Electrical data	
Supply voltage	12 ... 24 V
Signal output	0,25 ... 4,75 V
Alarm output	PNP
Response time	5 ms
Resolution	0,5 ... 1 mm
Linearity	2 % FS

Part numbers	
KPTA 6E6-4P-C-DN	<b>B 261 209 671</b>
Offer drawing	<b>A 261 209 671</b>
ASL 6-06-05PD-HE	<b>B 261 209 672</b>
Offer drawing	<b>A 261 209 672</b>

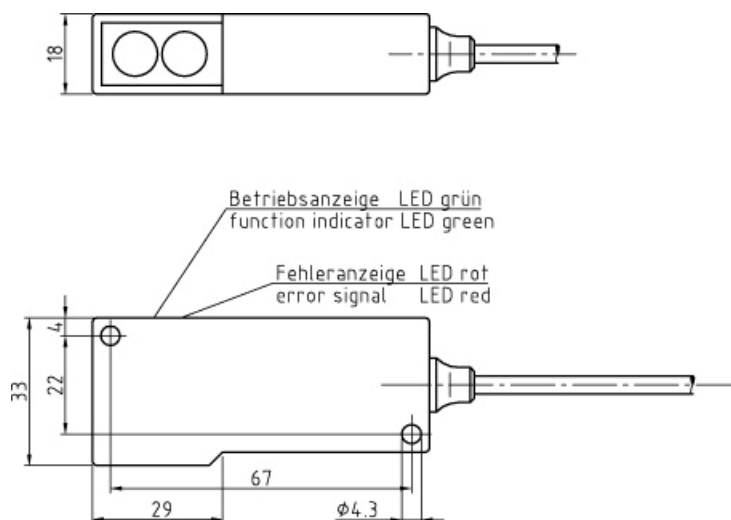



# Yaw Rate Sensor

## Yaw Rate Sensor YRS 2

This sensor is designed to measure the yaw rate and lateral acceleration of the vehicle. In order to achieve this, the sensor features both a measuring element for yaw rate and one for lateral acceleration, with one appropriate circuit. The measuring element for yaw rate is built using surface and bulk micromachining technology. Two surface micromachined accelerometers are located on two out of phase oscillating seismic masses.



### Mechanical data

Measuring range	100°/s
Overload	1000°/s
Weight	90 g

### Conditions for use

Temperature range	-40 ... 85°C
Shock	300 g

### Connector

Cable harness connector	D 261 205 358
-------------------------	---------------

### Electrical data

Supply voltage	8,0 ... 16 V
Current consumption	< 75 mA
Output range	0,5 ... 4.5 V
Reference voltage	2,5 V
Sensitivity	18 mVs/° [-100 ... 100°/s]
Non linearity	< 4 %

### Part number

<b>YRS 2</b>	<b>0 265 005 262</b>
Offer drawing	0 274 A00 005

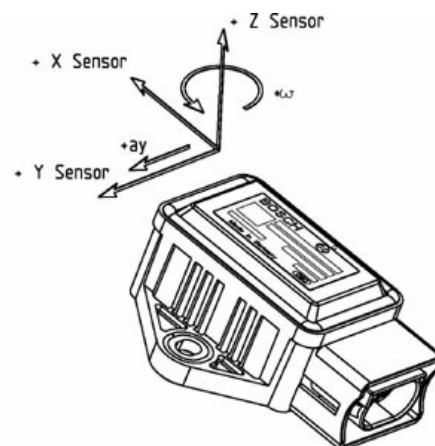
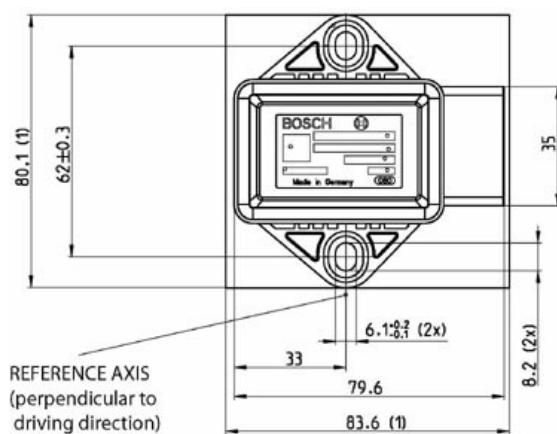

# Vehicle Components

# Chassis Control

## ABS M4

### Hydraulic modulator with integrated ECU

The ABS M4 is especially developed for motorsport use and contains all necessary functions for a four-channel ABS system. Reprogramming and diagnostic options are realised via K-line. An optional data logger connected via CAN can be used.



#### Mechanical Data

Dust and splash waterproof production based housing	
Vibration damped circuit board	
38 pin connector	
2 hydraulic valves per ABS channel	
2 brake circuits – front and rear	
2 circuit hydraulic high pressure pump	
2 hydraulic accumulators 3 ccm/each	
Standard fittings, master cylinder M12x1, brake cylinders M10x1	
Size	125 x 80,3 x 129,6 mm (ECU plus hydraulic unit)
Weight	approx. 2.200 g

#### ABS Outputs and Communication

Programming of individual car parameters via K-line
Diagnosis via K-line VSO
EEPROM programming via K-line
CAN link to external data logger
ABS safety light SILA

#### ABS Inputs

4 active wheel speed sensors DF11
Brake light switch
Pressure sensor
Longitudinal acceleration
Lateral acceleration
Yaw rate
12 position function switch for different setups
2 switch positions free programmable

#### Conditions for Use

Supply voltage	8-16 V, max. 26 V for 5 min
Max. peak voltage	35 V for 200 ms
Temperature	-30 to +130 °C
Shock vibrations	50 g less than 6 ms
Programming of individual car parameters via K-line	
Power consumption	8 W in idle
Power consumption	230 W when active

#### Part number

ABS M4	<b>0 265 232 160</b>
--------	----------------------

# Injection Valves

## Injection Valve EV 6

The development of the EV 6 took into account all the essential functional requirements which originate from injector operation in multipoint electronic fuel injection systems (EFI).

This resulted in: low weight, “dry” solenoid winding, plastic encapsulation, finely matched flow-rate classes, good valve-seat sealing, excellent hot-start capabilities, close tolerances of the specified functional values, high level of corrosion resistance and long service life.



Mechanical data	
System pressure	max. 8 bar
Weight	45, 8 g

Electrical data	
Solenoid resistance	e.g. 12 Ω
Max. power supply	16 V

Conditions for use	
Fuel input	axial (top-feed)
Operating temperature	-40 ... 110°C
Permissible fuel temperatures	≤ 70°C
Climate proofness corresponds to saline fog test	DIN 53 167

Technical data						
Order numbers	Design	Fuel type	Spray type	Flow rate at 3 bar (N-Heptan)	Spray angle α	Impedance
<b>B 280 431 126</b>	Standard	Gasoline	C	261,2 g/min	25°	12 Ω
<b>B 280 431 127</b>	Standard	Gasoline	C	261,2 g/min	70°	12 Ω
<b>0 280 155 737</b>	Long	Gasoline	C	261,2 g/min	15°	12 Ω
<b>B 280 431 128</b>	Standard	Gasoline	C	364,3 g/min	25°	12 Ω
<b>B 280 431 129</b>	Standard	Gasoline	C	364,3 g/min	70°	12 Ω
<b>B 280 431 130</b>	Standard	Gasoline	C	493,1 g/min	25°	1,2 Ω
<b>B 280 431 131</b>	Standard	Gasoline	C	493,1 g/min	70°	1,2 Ω
<b>0 280 156 012</b>	Standard	Gasoline	C	310,1 g/min	20°	12 Ω
<b>B 280 434 499_01</b>	Standard	Methanol	C	658 g/min	25°	12 Ω
<b>B 280 434 499_02</b>	Standard	Gasoline	C	658 g/min	25°	12 Ω

Further injection valves on request.

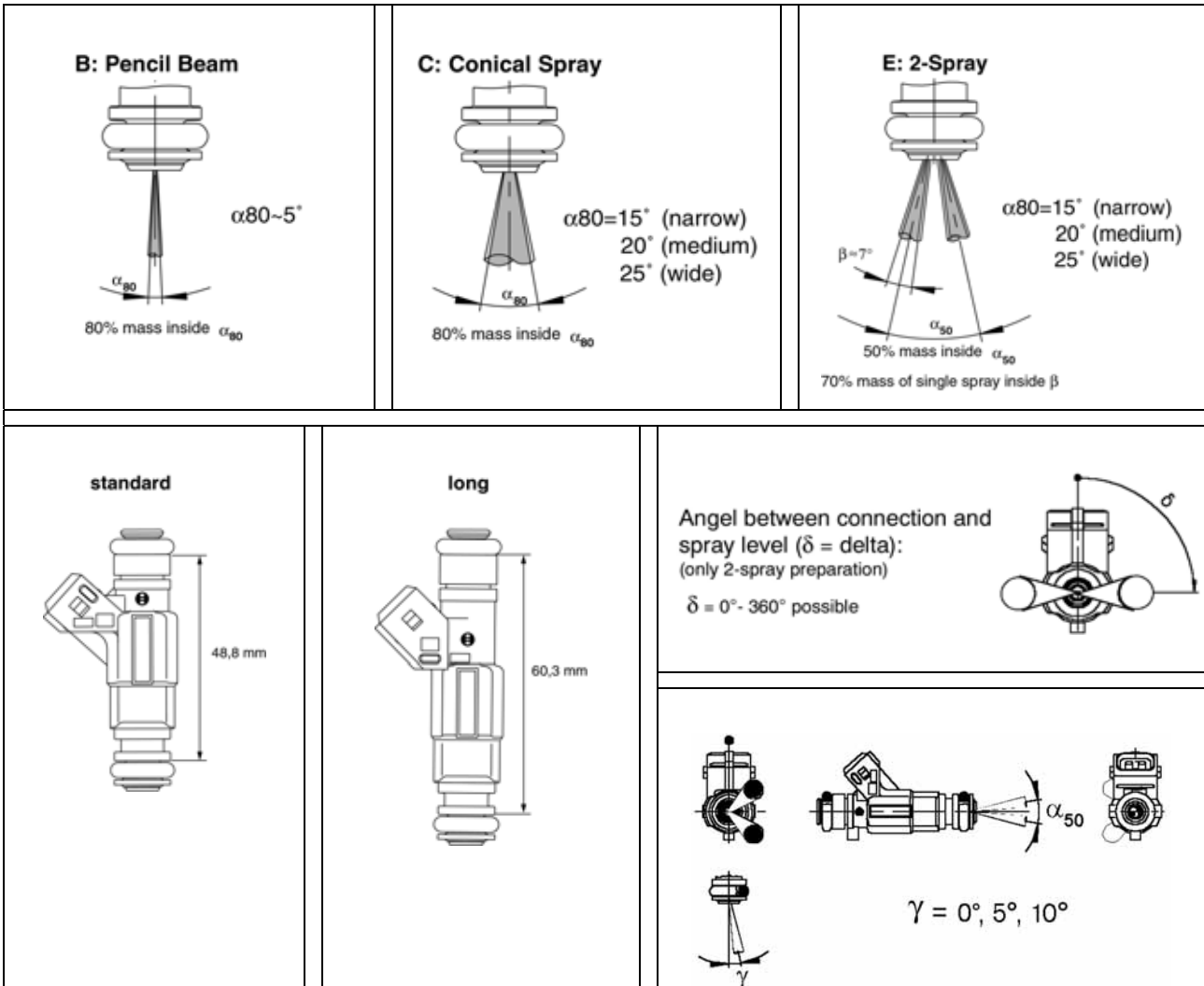

# Injection Valve EV 12

The EV 12 injector is a development based on the EV 6. Its main feature is the fact that the position of its injection point can be varied. Compared with the EV 6, the EV 12 injection point can be moved forward up to 20 mm.



### Mechanical data

System pressure	max. 8 bar
Weight	40 g

### Electronic data

Solenoid resistance	e.g. 12 $\Omega$
Max. power supply	16 V

### Conditions for use

Fuel input	axial (top-feed)
Operating temperatures	-40 ... 110°C
Permissible fuel temperatures	$\leq 70^\circ\text{C}$
Climate proofness corresponds to saline fog test	DIN 53 167

### Technical data

Order numbers	Design	Type	Flow rate at 3 bar (N-Heptan)	Spray angle				Impedance
				$\alpha$	$\beta$	$\gamma$	$\delta$	
0 280 155 892	Medium	E	269 g/min	15°	7°	10°	270°	12 $\Omega$
0 280 155 897	Medium	E	217 g/min	15°	7°	10°	270°	12 $\Omega$

Further special versions on request

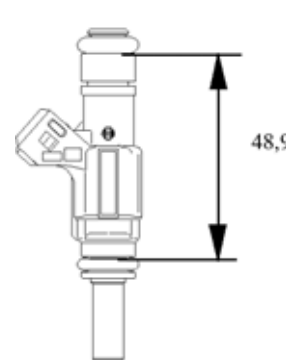
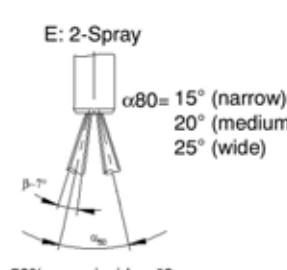
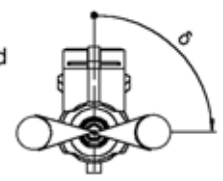
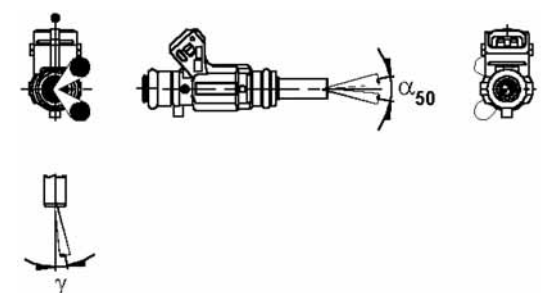
<p>Medium</p> 	<p>E: 2-Spray</p>  <p><math>\alpha_{80} = 15^\circ</math> (narrow)  <math>20^\circ</math> (medium)  <math>25^\circ</math> (wide)</p> <p>50% mass inside <math>\alpha_{50}</math>          70% mass of single spray inside <math>\beta</math></p>	<p>Angel between connection and spray level (<math>\delta = \text{delta}</math>):          (only 2-spray preparation)  <math>\delta = 0^\circ - 360^\circ</math> possible</p>  
---	---	--

## Injection Valve EV 14

The EV 14 injector is a further development based on the EV 6. It is even more compact, what allows its integration into the fuel rail.

In addition, this injector is also available with a variety of installation lengths, what makes an individual adaptation to the intake manifold possible.



Mechanical data	
System pressure	max. 8 bar
Weight	25 g
Spray angle	25° or 70°

Electrical data	
Solenoid resistance	e.g. 12 Ω
Max. power supply	16 V

Conditions for use	
Fuel input	axial (top-feed)
Operating temperatures	-40 ... 110°C
Permissible fuel temperatures	≤ 70°C
Installation lengths	48,65 mm
Climate proofness corresponds to saline fog test DIN 50 021	

Technical data						
Order numbers	Design	Type	Flow rate at 3 bar (N-Heptan)	Spray angle α	Impedance	
<b>B 280 436 038_06</b>	Standard	C	387,3 g/min	25°	12 Ω	
<b>B 280 436 038_02</b>	Standard	C	503,5 g/min	25°	12 Ω	
<b>B 280 436 038_05</b>	Standard	C	387,3 g/min	70°	12 Ω	
<b>B 280 436 038_01</b>	Standard	C	503,5 g/min	70°	12 Ω	

Further special versions on request.

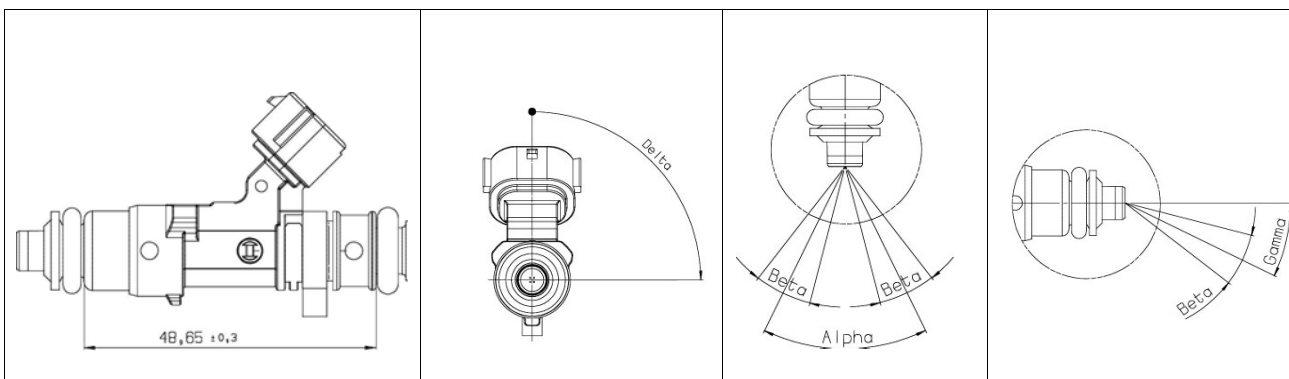

# HP Injection Valves

## HP Injection Valve HDEV 1.2

The HDEV 1.2 can be used in combination with direct injection systems as well as in high pressure manifold injection systems.

Its most remarkable features are the small size and weight and the freedom in defining both – spray and jet. Every jet is free definable in terms of position, flow rate and penetration. Moreover, asymmetric sprays are possible.







Mechanical data	
System pressure	max. 200 bar
Flow rate	e.g. 30 ccm/sec at 100 bar
Weight	78 g
Length	85 mm

Electrical data	
Resistance	0,9 Ω
Voltage	90 V
Peak current	20 A

Conditions for use	
Fuel input	axial (top-feed)
Operating temperatures	-30 ... 120 °C
Permissible fuel temperatures	< 80 °C

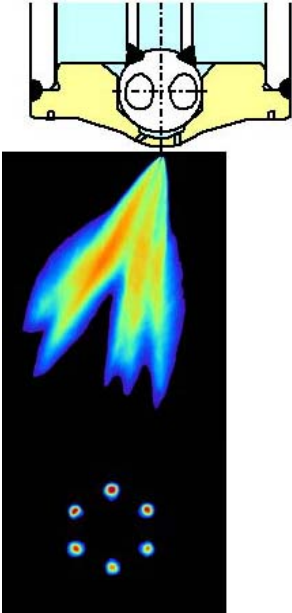
Part number	
HDEV 1.2	on request

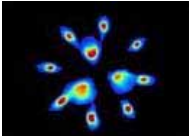
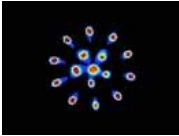
### Examples of variations, further variations on request

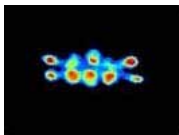
	 <p>Jets on a circle</p>	 <p>Jets on a circle and a middle jet</p>
	 <p>Jets on two circles</p>	 <p>Jets on two circles and a middle jet</p>
	 <p>Jet configuration regarding the spark plug position</p>	 <p>Flat jet configuration</p>



## HP Injection Valve Mini-HDEV 1.2

The Mini HDEV 1.2 can be used in high pressure manifold injection systems.

Its most remarkable features are the small size and weight and the freedom in defining both – spray and jet. Every jet is free definable in terms of position, flow rate and penetration. Moreover, asymmetric sprays are possible.







Mechanical data	
System pressure	max. 200 bar
Flow rate	e.g. 30 ccm/sec at 100 bar
Weight	48 g
Length	51 mm

Electrical data	
Resistance	1,1 $\Omega$
Voltage	14 V
Peak current	13,2 A

Conditions for use	
Fuel input	axial (top-feed)
Operating temperatures	-30 ... 120°C
Permissible fuel temperatures	< 80°C

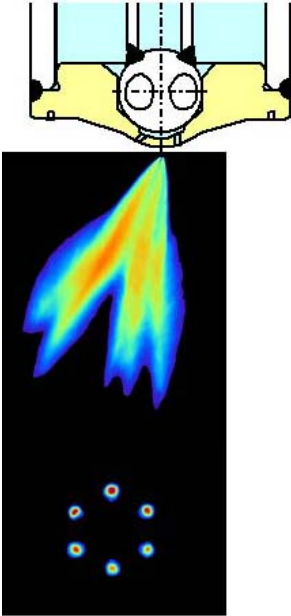
Part number	
Mini-HDEV 1.2	<b>on request</b>

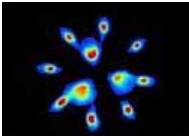
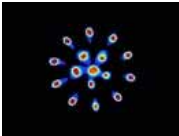
### Examples of variations, further variations on request

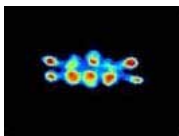
	 <p>Jets on a circle</p>	 <p>Jets on a circle and a middle jet</p>
	 <p>Jets on two circles</p>	 <p>Jets on two circles and a middle jet</p>
	 <p>Jet configuration regarding the spark plug position</p>	 <p>Flat jet configuration</p>

# HP Injection Valve Mini-HDEV LV

The Mini-HDEV LV can be used in high pressure manifold injection systems.

Its most remarkable features are the small size and weight and the freedom in defining both – spray and jet. Every jet is free definable in terms of position, flow rate and penetration. Moreover, asymmetric sprays are possible.







Mechanical data	
System pressure	max. 100 bar
Flow rate	e.g. 30 ccm/sec at 100 bar
Weight	48 g
Length	51 mm

Electrical data	
Resistance	< 0,2 Ω
Voltage	14 V
Peak current	26 A

Conditions for use	
Fuel input	axial (top-feed)
Operating temperatures	-30 ... 120°C
Permissible fuel temperatures	< 80°C

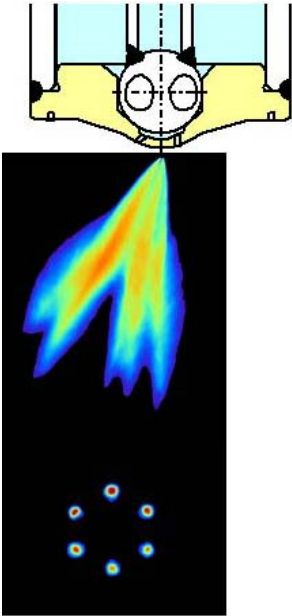
Part number	
HPI Valve Mini-HDEV LV	<b>on request</b>

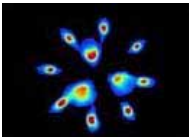
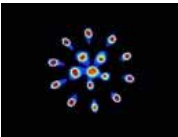
## Examples of variations, further variations on request

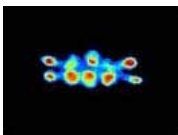
	 <p>Jets on a circle</p>	 <p>Jets on a circle and a middle jet</p>
	 <p>Jets on two circles</p>	 <p>Jets on two circles and a middle jet</p>
	 <p>Jet configuration regarding the spark plug position</p>	 <p>Flat jet configuration</p>

## HP Injection Valve Mini-HDEV LV 8A

The Mini-HDEV LV 8A is high pressure injector, which is developed to be used in high performance gasoline engines with a manifold injection system.

The function of the Mini-HDEV LV 8A is both to meter out the fuel and to obtain a well-defined mixture of fuel and air. It is an inward opening solenoid injector which is optimized regarding very short opening and closing times, which ensures a very stable linearity at short injection times. It is suitable for a standard peak and hold power stage based on 12 V.

Its most remarkable features are the small size and weight. Another benefit of this injector is a high spray variability concerning spray angle and spray shape. Also the flow rate can be defined in a big range. An additional advantage of this injector is a high accuracy regarding leakage and linearity.



Application	
Application	335 ... 2000 g/min @ 100 bar
Fuel Input	Top-Feed Injector
Fuel	Gasoline
Fuel Input	Top-Feed Injector
Operating Pressure	100 bar
Operating Temperature Range	-20 °C ... 140 °C
Storage Temperature Range	-20 °C ... 70 °C

Mechanical data	
Weight w/o cable	48 g
Diameter	20,7 mm
Length	51,6 mm
Max. Vibration	600 m/s <sup>2</sup> (guide value)

Electrical data	
Peak Power Supply Us	12 V
Peak Current	7,5 A
Peak Sustain Time	800 µs
Hold Power Supply	12 V
Hold Current	3,5 A
Coil Resistance	270 mΩ

**Connectors and Cable**

Cable Size	AWG 18
Cable Length	< 100 cm
Sleeve	DR 25

Various military and automotive connectors on request.

**Application Hint**

The injector can be supplied by a peak and hold power stage with maximum 8 A @12 V.

If your application conditions will not match the listed performance data, please ask for consultancy at Bosch Motorsport.

The injector can be cleaned (mechanically or chemically) if the tip will not be damaged.

Do not use supersonic cleaning.

Please find further application hints in the offer drawing (<http://www.bosch-motorsport.com>).





**Characteristic**

Spray Type	Multihole
Number of Holes	6 ... 16
Spray Angle Overall	< 100°
Spray Angle Single Beam	8° ... 18°
Static Flow Tolerance	+/- 4 %
Dynamic Flow Tolerance	+/- 4 % @ $t_i = 1,5$ ms
Leakage	< 2,0 mm <sup>3</sup> /min @ 23 °C
Fly Time ( $t_{on}$ )	220 $\mu$ s
Closing Time ( $t_{off}$ )	250 $\mu$ s
Droplet Size SMD	15 $\mu$ m
<b>Example Spray Pattern</b>	
Static Flow	335 ... 2000 g/min @ 100 bar

**Part number**

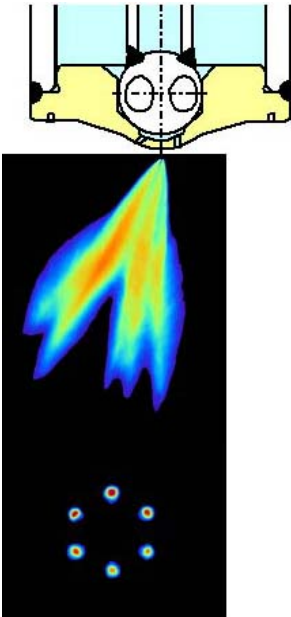
Mini-HDEV LV 8A **on request**

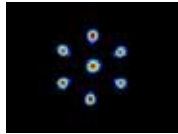
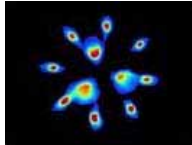
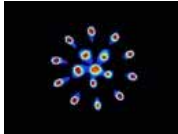
**Examples of variations, further variations on request**

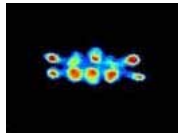
	 <p>Jets on a circle</p>	 <p>Jets on a circle and a middle jet</p>
	 <p>Jets on two circles</p>	 <p>Jets on two circles and a middle jet</p>
	 <p>Jet configuration regarding the spark plug position</p>	 <p>Flat jet configuration</p>

# Power Stage Units

## HPI 1.16 LV / LVD

In combination with a Bosch Motorsport ECU the HPI 1.16 Box enables the running of high pressure injection valves. The injector current is realised by a switched current regulation with booster period, pick-up period, holding period and re-charging period.

This HPI Box can be used for example in Formula 1 race cars.



## HPI 1.16 LV

Mechanical data	
Max. number of cylinders	10
Dust and waterproof aluminium housing	
Filtered connectors in military technology with high pin density	
Vibration damped printed circuit boards	
Flexible housing fixation points	
Size without connectors	135 x 101 x 43 mm
Weight	560 g
Communication interfaces	1 CAN, 1 K-Line

Conditions for use	
Housing temperature	-25 ... 85 °C
Operating voltage	8 ... 18 V
Nominal voltage	14,0 V
Max. vibration	<i>Vibration profile 1 (see Appendix)</i>

Electrical data	
Optimised for Bosch injection valves Mini-HDEV LV	
Max. rpm	20.000
Internal voltage regulator	-

Part number	
HPI 1.16 LV	<b>F 01T A20 017</b>

## HPI 1.16 LVD

Mechanical data	
Max. number of cylinders	10
Dust and waterproof aluminium housing	
Filtered connectors in military technology with high pin density	
Vibration damped printed circuit boards	
Flexible housing fixation points	
Size without connectors	135 x 101 x 43 mm
Weight	710 g
Communication interfaces	1 CAN, 1 K-Line

Conditions for use	
Housing temperature	-25 ... 70 °C
Operating voltage	8 ... 18 V
Nominal voltage	14,0 V
Max. vibration	<i>Vibration profile 1 (see Appendix)</i>

Electrical data	
Optimised for Bosch injection valves Mini-HDEV LV	
Max. rpm	20.000
Internal voltage regulator	14 ... 17 V

Part number	
HPI 1.16 LVD	<b>F 01T A20 016</b>

## HPI 1.16 HV / HVD

In combination with a Bosch Motorsport ECU the HPI 1.16 Box enables the running of high pressure injection valves. The injector current is realised by a switched current regulation with booster period, pick-up period, holding period and re-charging period.

This HPI Box can be used for example in racing series like DTM, 24 h Le Mans, etc.



### HPI 1.16 HV

Mechanical data	
Max. number of cylinders	10
Dust and waterproof aluminium housing	
Filtered connectors in military technology with high pin density	
Vibration damped printed circuit boards	
Flexible housing fixation points	
Size without connectors	135 x 101 x 43 mm
Weight	575 g
Communication interfaces	1 CAN, 1 K-Line

Conditions for use	
Housing temperature	-25 ... 85 °C
Operating voltage	8 ... 18 V
Nominal voltage	14,0 V
Max. vibration	<i>Vibration profile 1 (see Appendix)</i>

Electrical data	
Optimised for Bosch injection valves Mini-HDEV 1.2	
Max. rpm	12.500
Internal voltage regulator	-

Part number	
HPI 1.16 HV	<b>F 01T A20 019</b>

### HPI 1.16 HVD

Mechanical data	
Max. number of cylinders	10
Dust and waterproof aluminium housing	
Filtered connectors in military technology with high pin density	
Vibration damped printed circuit boards	
Flexible housing fixation points	
Size without connectors	135 x 101 x 43 mm
Weight	725 g
Communication interfaces	1 CAN, 1 K-Line

Conditions for use	
Housing temperature	-25 ... 70 °C
Operating voltage	8 ... 18 V
Nominal voltage	14,0 V
Max. vibration	<i>Vibration profile 1 (see Appendix)</i>

Electrical data	
Optimised for Bosch injection valves Mini-HDEV 1.2	
Max. rpm	12.500
Internal voltage regulator	65 ... 90 V

Part number	
HPI 1.16 HVD	<b>F 01T A20 018</b>

# Ignition Coils

## Single Fire Coil M

This ignition coil is specially designed for motorsport use. The electronic design connects high energy output with a small housing. The coil is available in a DR-25 sleeve with different options of connectors.



Electronic data	
High voltage	35 kV
I prim. (stand.)	10 A
Inductivity (prim.)	1,8 mH
Inductivity (sec.)	4,7 H
Resistance (prim.)	0,5 $\Omega$
Resistance (sec.)	4,4 k $\Omega$
Spark energy	33 mJ
U prim. (clamp.)	500 V
Voltage gradient	3,3 kV/ $\mu$ s

Mechanical data	
Weight	180 g
Vibration	80 g/5 ... 250 Hz

Conditions for use	
Temperature range	-20 ... 130 $^{\circ}$ C

Part number	
	<b>B 261 209 192</b>

Dwell time (ms)					
Ubatt	4 A	6 A	8 A	10 A	
8 V	1,30	2,40	3,20	4,20	
10 V	1,00	1,60	2,40	3,40	
12 V	0,80	1,25	1,80	2,40	
14 V	0,65	1,05	1,40	1,80	
16 V	0,55	0,85	1,18	1,46	

## Single Fire Coil P

This coil is low cost concept for cylinder head installation.



Electrical data	
High voltage	35 kV
I prim. (stand.)	8,5 A
Inductivity (prim.)	2,8 mH
Inductivity (sec.)	16 H
Resistance (prim.)	0,37 $\Omega$
Resistance (sec.)	8,8 k $\Omega$
Spark energy	45 ... 55 mJ
U prim. (clamp.)	260 V
Voltage gradient	1,6 kV/ $\mu$ s

Conditions for use	
Temperature range	-40 ... 140°C

Mechanical data	
Weight	260 g
Vibration	40 g/5 Hz ... 2 kHz

Connector	
Cable harness connector	D 261 205 334

Part number	
	B 261 208 315
Offer drawing	A 221 152 139

Dwell time (ms)						
Ubatt	4 A	5 A	6 A	7 A	8 A	
8 V	2,90	4,00	5,50	7,80		
10 V	2,00	2,70	3,50	4,40	5,20	
12 V	1,65	2,10	2,65	3,17	3,52	
14 V	1,35	1,75	2,15	2,55	2,90	
16 V	1,10	1,40	1,75	2,05	2,35	



## Single Fire Coil PT

This single fire coil PT is a low cost concept for cylinder head installation with an integrated transistor for use in combination with ECUs without internal ignition power stage.

During the current feed on the primary side of the coil, energy is stored in the magnetic circuit. A quick turn off of the primary supply occurs a reloading on the secondary side. There the stored energy at the spark plug is reduced in the form of a high voltage spark. The spark ignites the fuel-air-ratio.



Application	
Spark Energy	≤ 38 mJ
Primary Current	≤ 8,0 A
Operating Temperature Range Outer Core	-20 ... 140 °C
Storage Temperature Range	-40 ... 100 °C
Max Vibration	400 m/s <sup>2</sup> @ 5 ... 2500 Hz

Mechanical data	
Weight w/o cable	194 g
Fixation	screw on

Electrical data	
Primary Resistance with/without Cable	incapable of measurement
Secondary Resistance without Noise Suppression	incapable of measurement
Voltage Supply	6 ... 16,5 V
Dwell Time	see Primary Characteristic Diagram
High Voltage	≥ 34 kV [@8 pF  1MΩ]
High Voltage Rise Time	≤ 2,8 kV / μs
Spark Current	≤ 78 mA
Spark Duration	see Secondary Characteristic Diagram
Noise Suppression	1 kΩ integrated
Suppressure- / EFU-Diode	Yes
Integrated Power Stage	Yes
Ion-Current-Signal	No

Characteristic	
Measure with Power Stage	BIP 373

### Primary Characteristic Diagram

I pri [A]	U batt [V]					
	6 V	8 V	10 V	12 V	14 V	16 V
5,0	7,2	4,2	3,2	2,3	1,9	1,6
6,0	10,0	5,8	3,6	2,6	2,1	1,8
7,0	14,0	7,2	4,0	2,9	2,2	1,9
8,0	-	8,6	4,4	3,1	2,4	2,0

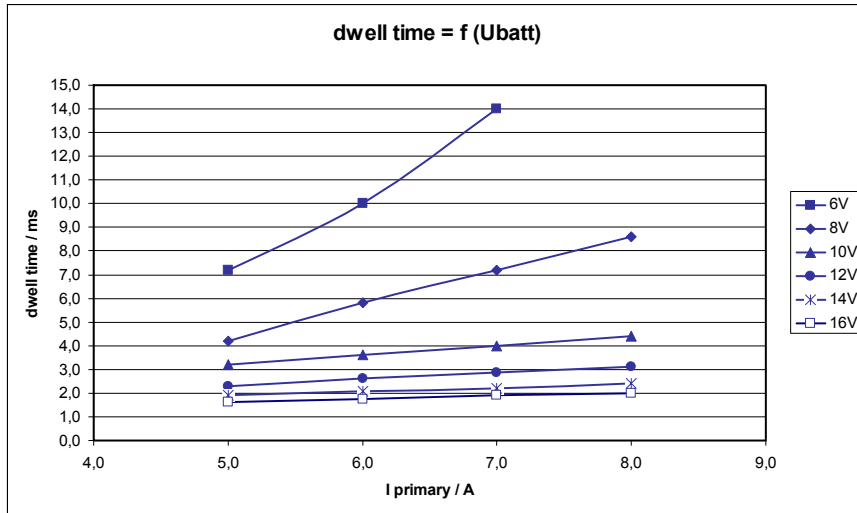

### Secondary Characteristic Diagram

	I pri [A]			
	5 A	6 A	7 A	8 A
Spark Energy [mJ]	24	29,3	34	37,3
Spark Duration [ms]	0,97	1,03	1,09	1,13
Spark Current [mA]	67	77	86	92
High Voltage [kV]	31	33,5	35,7	37,4

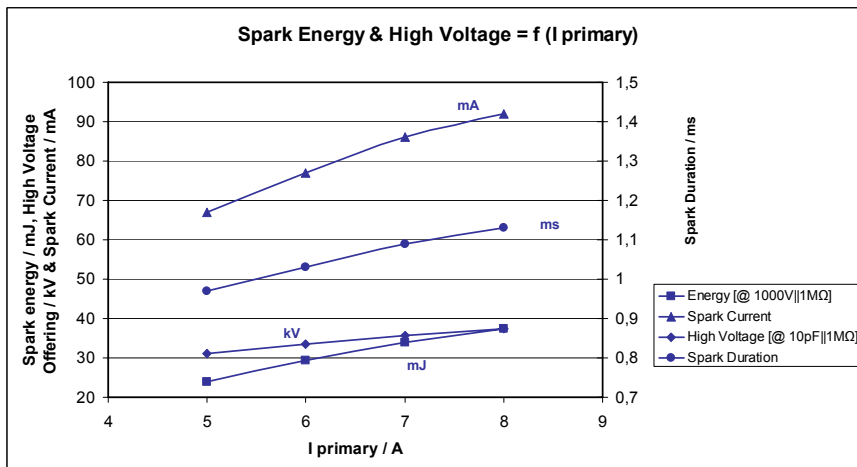

**Connections and Cable**

Pin 1	Control [ECU]
Pin 2	Ground [ECU]
Pin 3	Ubatt [Power Supply]

Various military and automotive connectors on request.

Please specify the requested cable length with your order.

**Application Hint**

During the mounting in the spark plug shaft please pay attention that the clamping and contacting is completed exactly to realize a safe connection between coil and spark plug.

This coil is with a integrated Power Stage (BIP 373). Use only with engine control units having an output current driver about 10 mA.

Please regard the specified limit values.

Please find further application hints in the offer drawing (<http://www.bosch-motorsport.com>).

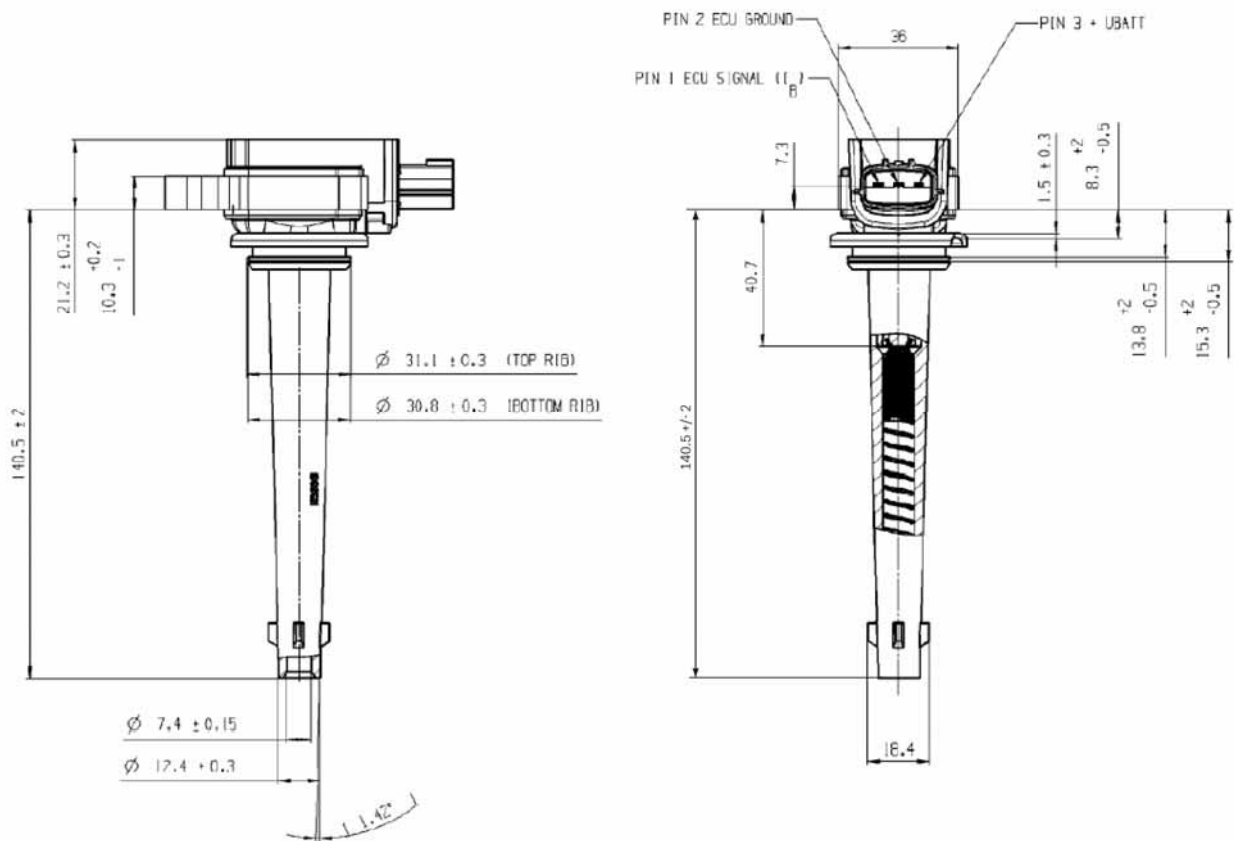
**Design**

**Part number**

Single Fire Coil PT                      0 221 604 014

## Single Fire Coil S

This ignition coil is specially designed for cylinder head mounting. The electronic design combines high energy output with a small housing. It is available in a DR-25 sleeve with different options of connectors.

Electric data and dimensions can be individually adapted to customer's requirements.

This coil is part of the higher performance segment.



Mechanical data	
Weight	148 g
Vibration	80 g/5 Hz ... 2,5 kHz
Diameter	22 mm

Conditions for use	
Temperature range	-40 ... 140 °C

Dwell time (ms), temperature of coil ca. 50 °C	
Ubatt	12,5 A
8 V	3350 μs
10 V	1750 μs
12 V	1250 μs
14 V	960 μs
16 V	800 μs

Electrical data	
High voltage	> 30 kV
I prim. (stand.)	12 A
Resistance (prim.)	0,2 Ω
Spark energy	33 ... 40 mJ
U prim. (clamp.)	390 V
Voltage gradient	3,3 kV/μs

Part number	
Single Fire Coil S	<b>B 221 141 834_02</b>

## Single Fire Coil S16

This single fire coil was exclusively developed for the use in Formula 1 high performance engines. It is designed for the direct mounting on the spark plug.

During the current feed on the primary side of the coil, energy is stored in the magnetic circuit. A quick turn off of the primary supply occurs a reloading on the secondary side. There the stored energy at the spark plug is reduced in the form of a high voltage spark. The spark ignites the fuel-air ratio.

The main feature and benefit of this high performance coil is his robustness in hard racing applications, the high energy efficiency and the optional ion current measure capability. The design of the upper (cable side) and the lower part (spark plug side) can be designed according to customer requirements.



Application	
Spark Energy	≤ 40 mJ
Primary Current	≤ 30 A
Operating Temperature Range	
Outer Core	0 ... 160 °C
Storage Temperature Range	-40 ... 100 °C
Max. Vibration	800 m/s <sup>2</sup>

Mechanical Data	
Diameter	16 mm
Length L	min. 90 mm
Weight w/o Cable	approx. 48 g
Fixation	Pluggable / Pressed

Electrical data	
Primary Resistance	approx. 230 mΩ
Secondary Resistance without Noise Suppression	incapable in measurement
Voltage Supply	12 ... 30 V
Dwell Time	200 ... 400 μs (14 V)
High Voltage	≤ 30 kV [@1MΩ 8pF]
High Voltage Rise Time	8 ... 12 kV/μs
Spark Current	250 ... 600 mA
Spark Duration	80 ... 300 μs [@1kV 1MΩ]
Noise Suppression	Yes
Suppressure-/EFU-Diode	Yes
Integrated Power Stage	No
Ion Current Signal	Possible

Characteristic	
Measure with Power Stage	IGBT IRF_S Uce=600 V

### Characteristic Dwell Time

I pri [A]	U batt [V]							
	12 V	14 V	16 V	18 V	20 V	24 V	27 V	30 V
12,0	155,5	117,0	99,0	84,0	72,0	57,0	49,0	43,0
15,0	208,5	157,0	132,0	112,0	97,0	77,0	66,0	58,0
18,0	274,0	209,0	168,0	142,0	123,0	97,0	83,0	72,0
20,0	322,0	244,0	194,0	163,0	141,0	111,0	95,0	82,0
25,0	511,0	359,0	273,0	225,0	191,0	148,0	125,0	109,0
30,0	-	-	410,0	310,0	255,0	192,0	160,0	137,0

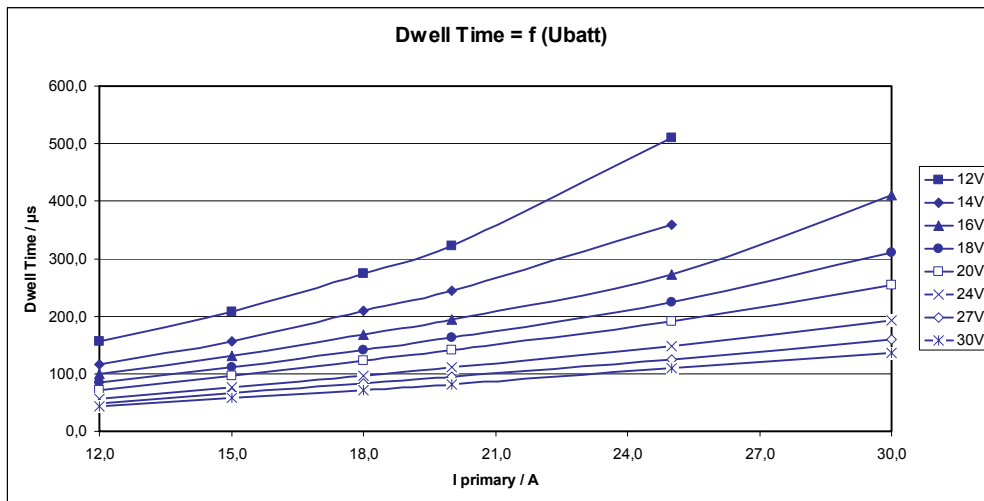

### Characteristic Output

	I primary [A]					
	12 A	15 A	18 A	20 A	25 A	30 A
Spark Energy [mJ]	5,6	8,9	13,2	16,3	24,9	35,4
Spark Duration [μs]	70	88,4	105	116	140	164
Spark Current [mA]	200	252	314	350	444	540
High Voltage [kV]	14,6	18,6	22	24,5	29,6	34,6

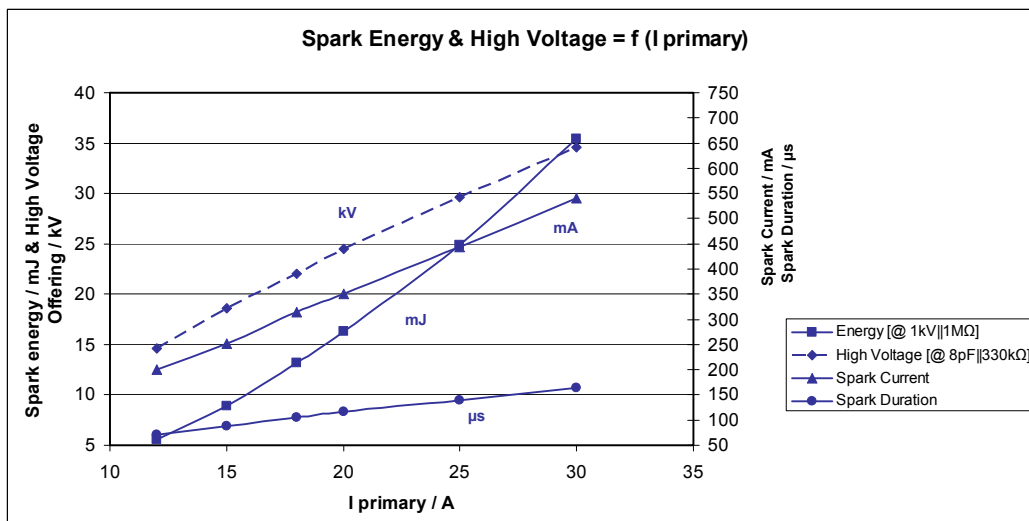

**Connectors and Cables**

Cable Size AWG 18

Cable Length &lt; 1000 mm

Various military and automotive connectors on request.

**Application Hint**

During the mounting in the spark plug shaft please pay attention that the clamping and contacting is completed exactly to realize a safe connection between coil and spark plug.

The coil is only for usage with engine control units having an integrated output stage, i. e. IGBT IRF5036S.

Please regard the specified limit values.

 Please find further application hints in the offer drawing (<http://www.bosch-motorsport.com>).

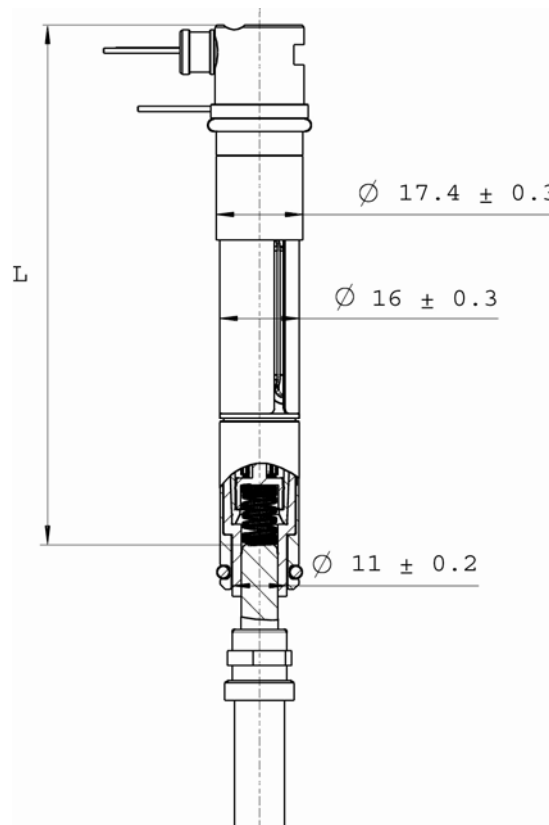
**Design**

**Part number**

Single Fire Coil S16

**on request**

## Double Fire Coil 2x2

### 2 x 2 Sparks

This dual spark ignition coil is designed for low-cost applications in 4-cylinder engines.

During the current feed on the primary side of the coil, energy is stored in the magnetic circuit. A quick turn off of the primary supply occurs a reloading on the secondary side. There the stored energy at the spark plug is reduced in the form of a high voltage spark. The spark ignites the fuel-air-ratio.

The advantage of this coil is that the ECU needs only two internal power stage for supplying a 4-cylinder engine.



Application	
Spark Energy	≤ 100 mJ
Primary Current	≤ 8 A
Operating Temperature Range Outer Core	-20 ... 120 °C
Storage Temperature Range	-40 ... 100 °C
Max Vibration	200 m/s <sup>2</sup> [@ 5 ... 250 Hz]

Mechanical Data	
Weight w/o Cable	920 g
Fixation	screw on

Electrical Data	
Primary Resistance with/without Cable	500 mΩ
Secondary Resistance without Noise Suppression	13,3 kΩ
Voltage Supply	6 ... 24 V
High Voltage	≥ 33 kV [@ 1 MΩ  10 pF]
High Voltage Rise Time	≤ 1,1 kV / μs
Spark Current	≤ 74 mA
Noise Suppression	No
Suppressure- / EFU-Diode	No
Integrated Power Stage	No
Ion-Current-Signal	<b>No</b>



**Primary Characteristic Diagram**

I pri [A]	U batt						
	6 V	8 V	10 V	12 V	14 V	16 V	24 V
5,0	7,0	4,2	3,1	2,4	2,0	1,7	1,0
6,0	9,2	5,3	3,8	2,9	2,4	2,0	1,2
7,0	12,7	6,6	4,5	3,5	2,8	2,4	1,5
8,0	-	7,9	5,3	4,0	3,2	2,7	1,6

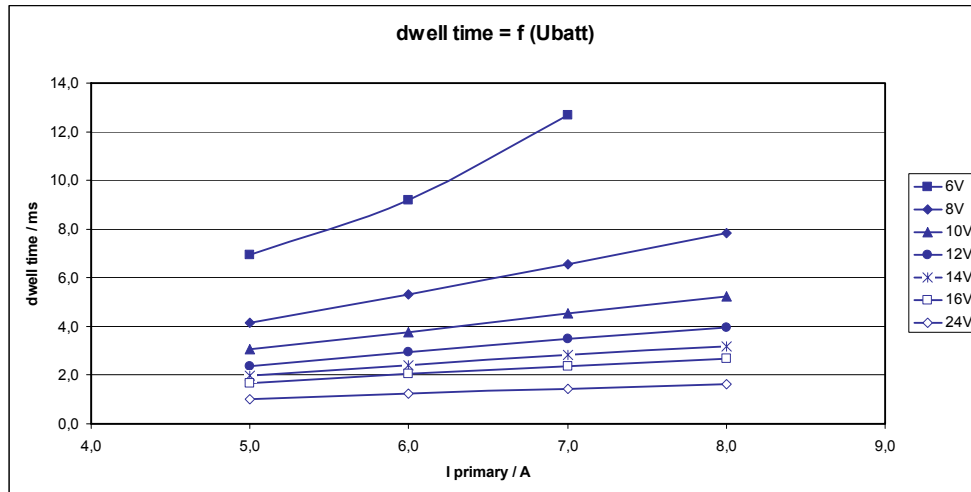
**Secondary Characteristic Diagram**

	I primary			
	5 A	6 A	7 A	8 A
Spark Energy [mJ]	46,5	65,3	83,3	99,9
Spark Duration [ms]	2,02	2,3	2,54	2,71
Spark Current [mA]	46	56,8	65,6	74,4
High Voltage [kV]	25,8	30,2	34,8	37,8

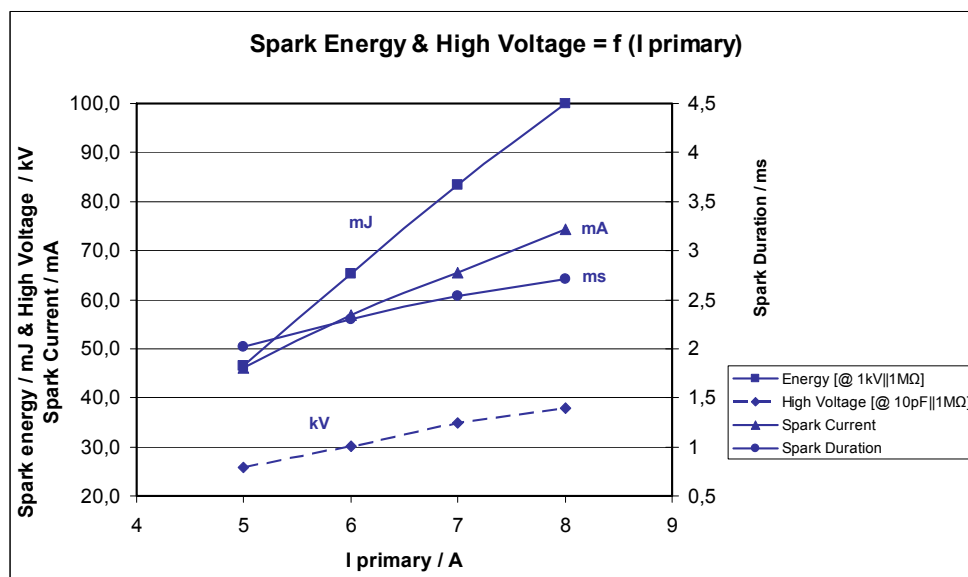

### Connectors and Cables

Pin 1	ZS 2 [KI. 1]
Pin 2	U <sub>batt</sub> [KI. 15]
Pin 3	ZS 1 [KI. 1]

Various military and automotive connectors on request.

Please specify the requested cable length with your order.

### Application Hint

The coil can screw on the engine.

Ignition cables are needed to connect the coil with the spark plug.

The ECU must have two internal power stages.

Please regard the specified limit values.

Please find further application hints in the offer drawing (<http://www.bosch-motorsport.com>).

### Part number

Double Fire Coil 2x2

**0 221 503 407**

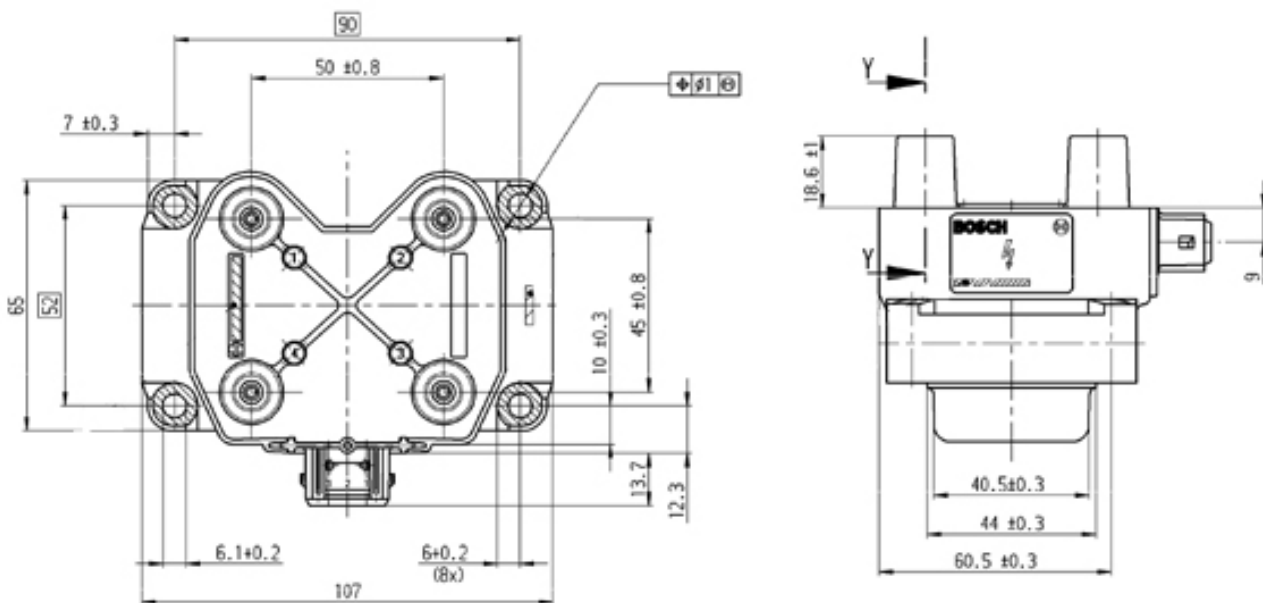

# Double Fire Coil 3x2

## 3 x 2 Sparks

This dual spark ignition coil is designed for low-cost applications in 6-cylinder engines.



Mechanical data	
Weight	1300 g
Vibration	20 g/5 ... 250 Hz

Conditions for use	
Temperature range	-20 ... 120°C

Primary connector	
Offer drawing	1 284 485 118

Electrical data	
High voltage	33 kV
I prim. (stand.)	7,5 A
Inductivity (prim.)	3,7 mH
Inductivity (sec.)	38 H
Resistance (prim.)	0,5 Ω
Resistance (sec.)	13,3 kΩ
Spark energy	70 mJ
U prim. (clamp.)	320 V
Voltage gradient	1,1 kV/μs

Part number	
	0 221 503 002
Offer drawing	A 221 151 810-006

Dwell time (ms)				
Ubatt	5 A	6 A	8 A	
8 V	6,0	8,5	12,0	
10 V	3,8	4,9	7,0	
12 V	2,8	3,5	5,0	
14 V	2,3	2,8	3,9	
16 V	2,0	2,4	3,0	

# Spark Plugs

## Spark Plugs

The engines of competition vehicles are exposed to high thermal stress because of running them at full load most of the time.

Spark plugs for this operating conditions often have precious metal center electrodes (platinum, silver) and a short insulator base. This causes a very small heat absorption and a good heat derivation through the center electrode.

Corresponding to the various field of operations we manufacture over 1400 different types of spark plugs in production. You can get these standard spark plugs from your local Bosch-service and most spare parts dealers. The range of products includes versions with various seats and threads, thread lengths and electrode positions, the design parts air-gap, surface-gap and surface-air-gap types. You can choose between versions with one to four ground electrodes, the center electrode can be made from various materials.

Moreover we offer special versions and small batches which you should not hesitate asking for.



# Fuel Pumps

## Fuel Pump FP 100

Fuel delivery: >100 l/h, 5 bar



Description	
Fuel delivery	>100 l/h
High temperature reduction	30 l/h
Supply voltage	13,5 V
Current consumption	5 A (5 bar)
Weight	725 g
Non return valve	external

Accessories	
Primary connector	

Part number	
	Y 580 701 456

Connections	
Intake side	M16 x 1,5
Pressure side	M12 x 1,5
Electrical	+: M4 / -: M5

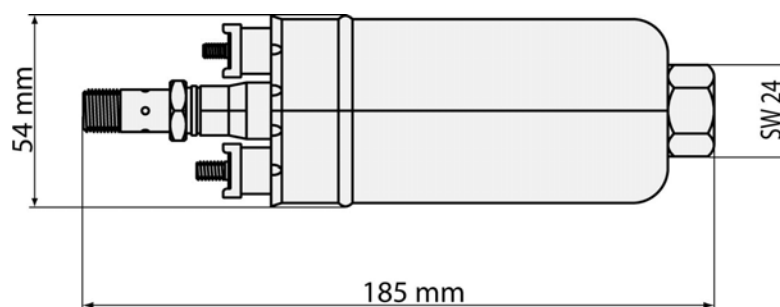

## Fuel Pump FP 165

Fuel delivery: >165 l/h, 5 bar



Description	
Fuel delivery	>165 l/h
High temperature reduction	30 l/h
Supply voltage	13,5 V
Current consumption	10 A (5 bar)
Weight	980 g
Non return valve	internal

Accessories	
Primary connector	

Part number	
	0 580 254 979
Offer drawing	A 580 152 325

Connections	
Intake side	M14 x 1,5
Pressure side	M12 x 1,5
Electrical	+: M4 / -: M5

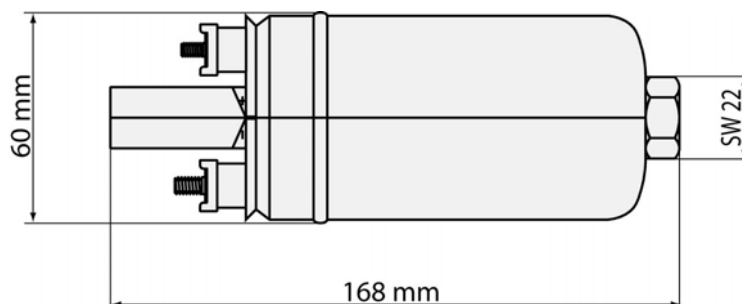

## Fuel Pump FP 200

Fuel delivery: >200 l/h, 5/8 bar after a break-in period of 20 h



Description	
Fuel delivery	>200 l/h
High temperature reduction	30 l/h
Supply voltage	13,5 V
Current consumption	13 A
Weight	1030 g
Non return valve	external

Accessories	
Primary connector	

Part numbers	
5 bar	<b>0 580 254 044</b>
8 bar	<b>B 261 205 413</b>
Offer drawing	<b>A 580 152 519</b>

Connections	
Intake side	M18 x 1,5
Pressure side	M12 x 1,5
Electrical	+: M6 / -: M5

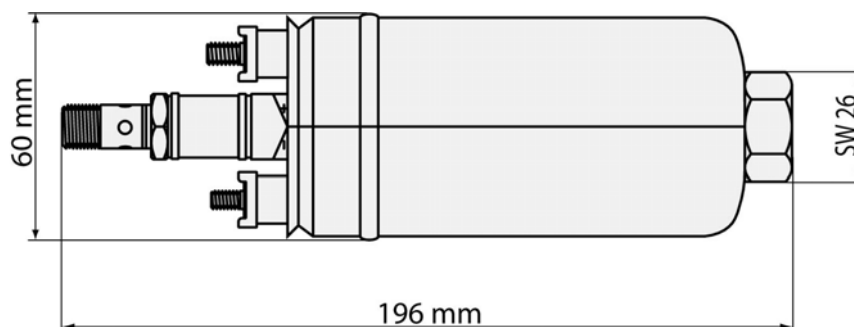

## HPI Fuel Pump HDP 1

The HDP 1 is a high pressure radial pump with three pistons. Designing it we set great value on a big delivery volume, as needed in motorsport applications. Variations in bore and stroke affect different deliveries.

This type of pump was used by different 24h-Le Mans winners.



Mechanical data	
Fuel delivery	0,66 ccm/0,80 ccm per rotation
Length	76,8 mm
Weight	1000 g
Enveloping circle	121,4 mm
Supply pressure	4 ... 6 bar
Output pressure	120 bar permanent 200 bar short time
Max. operating temperature	80 °C
Max. temperature of location	130 °C
Max. rotation per minute	9000

Connections	
Intake side	e.g. thread hole M10 x 1
Pressure side	e.g. thread hole M10 x 1

Part numbers	
Fuel delivery 0,66 ccm	<b>B 438 172 058</b>
Fuel delivery 0,80 ccm	<b>B 438 172 061</b>



## Diesel Fuel Pump DFP 300

Fuel delivery: >300 l/h, 5 bar relative

This electrical diesel fuel pump without non-ferrous metal is especially designed for diesel applications. A modified rotor provides higher fuel delivery than the series version. Its tight housing with screwed connectors fits to any intank or inline fuel circuit. This pump results in an excellent weight-to-power ratio.



Description	
Fuel delivery at fuel temp. < 90 °C	>300 l/h
Fuel delivery increase after break-in period of 20 h	20 l/h
Supply voltage	13,5 V
Current consumption	17,2 A
Weight	700 g
Non return valve	internal
Housing version	inline
Allowed diesel spec.	EN590

Connections	
Intake side	M18 x 1,5
Pressure side	M12 x 1,5
Electrical	+: M6 / -: M5

Part numbers	
DFP 300l/h	<b>B 261 205 366</b>

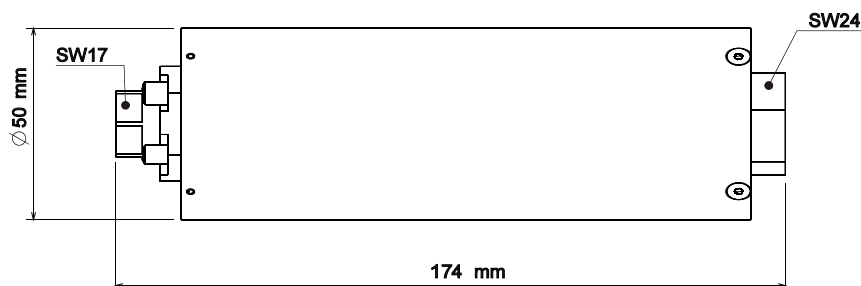

# Fuel Pressure Regulators

## Fuel Pressure Regulator 05-40 A

Pressure range: 0,5 ... 4 bar



Mechanical data	
Supply	8 mm, tube connector
Reflow	8 mm, tube connector
Reflow quantity	min. 15 l/h, max. 220 l/h

Part number	
	B 280 500 139
Offer drawing	A 280 500 104

Description	
Sheet steel housing with manifold connection	

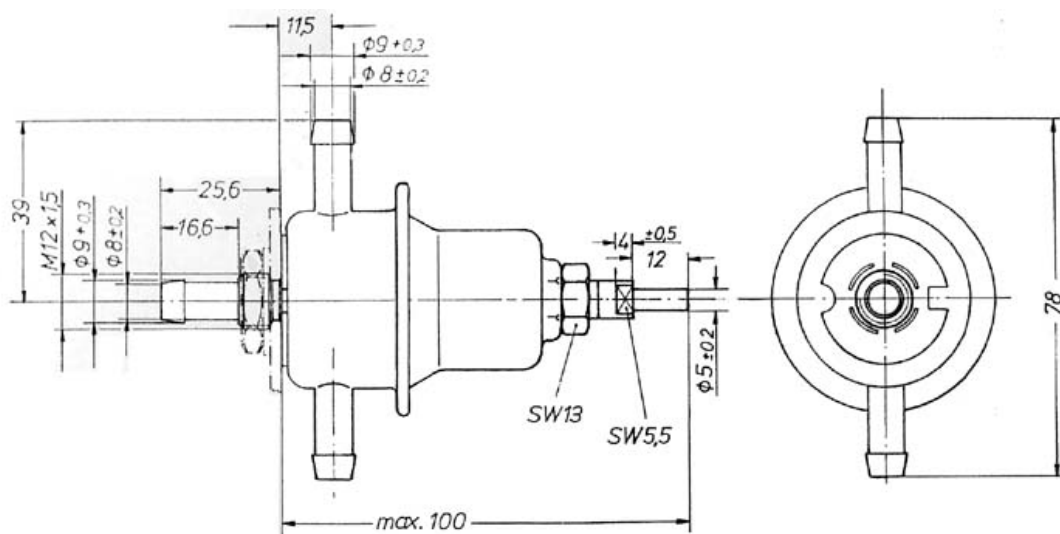

# Fuel Pressure Regulator 14-50

Pressure range: 1,4 ... 5 bar



## Mechanical data

Supply	10 mm, O-ring
Reflow	8 mm, tube connector
Reflow quantity	min. 15 l/h, max. 220 l/h

## Part number

1,4 ... 5 bar	<b>B 280 500 701</b>
---------------	----------------------

## Description

Sheet steel housing with manifold connection

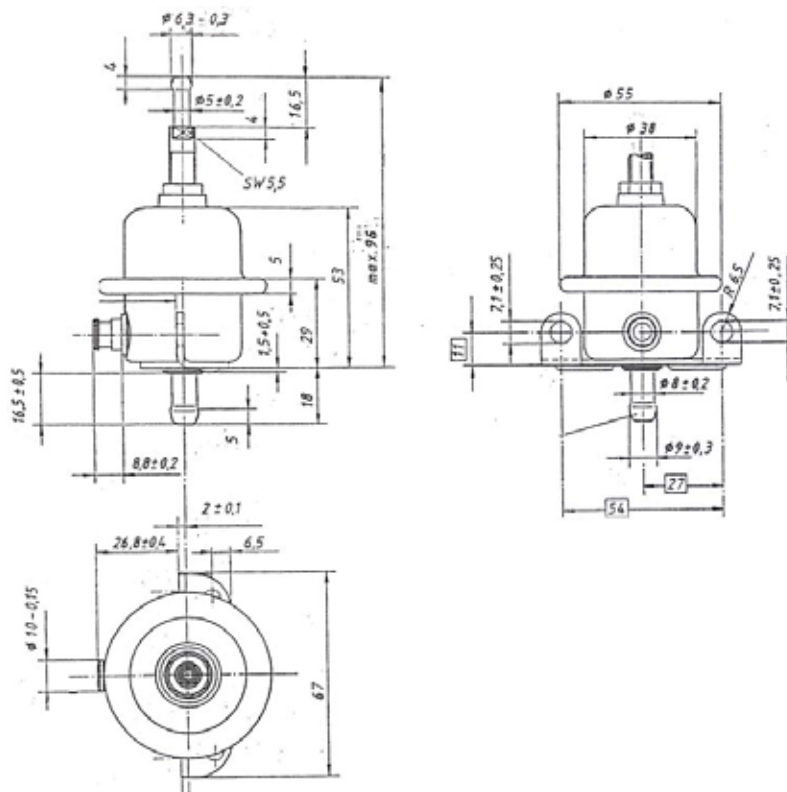



# Fuel Pressure Regulator 19-50

Pressure range: 1,9 ... 5 bar



Mechanical data	
Supply	M14 x 1,5
Reflow	M14 x 1,5
Reflow quantity	min. 15 l/h, max. 220 l/h

Part number	
	<b>B 280 500 737</b>
Offer drawing	<b>A 280 500 662</b>

Description	
Sheet steel housing with manifold connection	

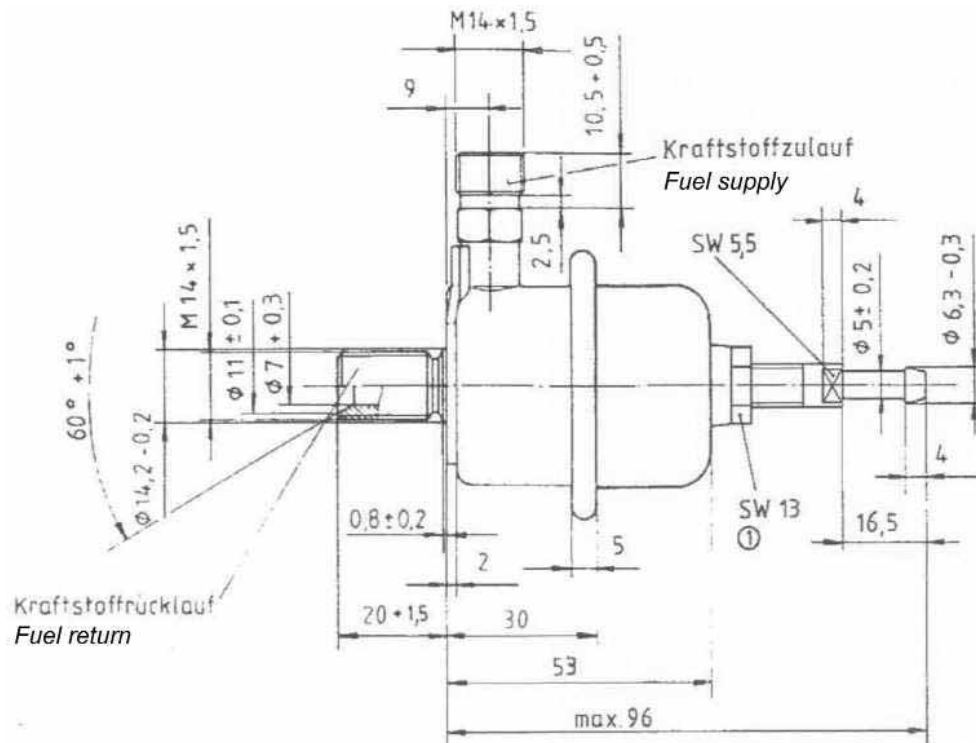



# Fuel Pressure Regulators Mini/Mini M

## Pressure range: 6/8/10 bar

We offer this mini pressure regulator in two fuel-specific versions: the standard version for use with petrol and a M-version for use with methanol.



Mechanical data	
Supply	25 mm, O-ring
Reflow	9,15 mm, O-ring
Reflow quantity	min. 30 l/h, max. 400 l/h

Description	
Light weight aluminium housing	
No manifold connection	

Part numbers	
<b>Standard version</b>	
6 bar	<b>B 261 208 106</b>
8 bar	<b>B 261 208 108</b>
10 bar	<b>B 261 208 109</b>
<b>Methanol version</b>	
6 bar	<b>B 261 208 121</b>
8 bar	<b>B 261 208 122</b>
10 bar	<b>B 261 208 123</b>

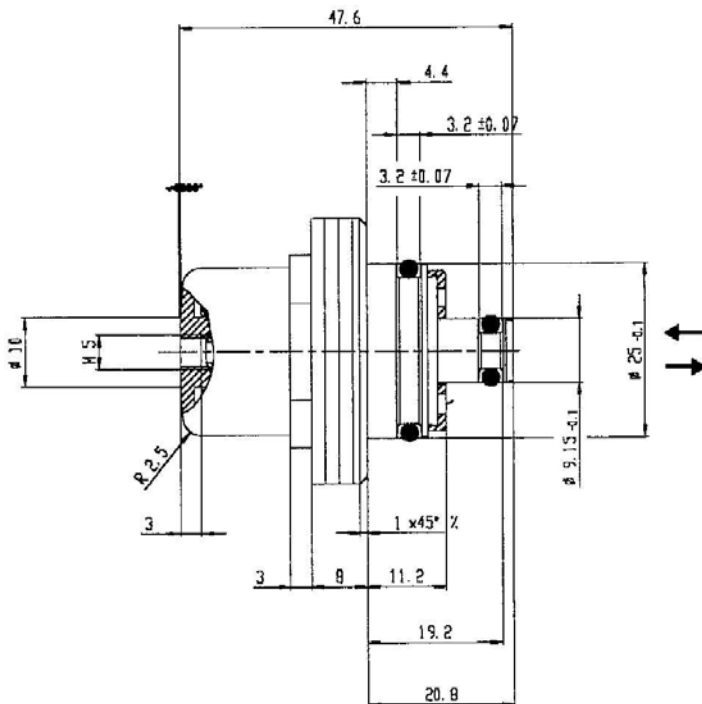

### Erledigung durch Kunden Effect by customer

- O-Ringe leicht mit sauberem Motorenöl einölen  
*Oil O-rings lightly with clean engine oil*
- Nach der Montage an Kraftstoffzuteiler ist Dichtheitsprüfung durchzuführen  
*Leaktest after installation*
- Bei Ausbau und Wiederverwendung des Druckreglers müssen die O-Ringe überprüft werden  
*When the pressure regulator is removed and will be reused, the O-rings must be checked*
- Betrieb des Druckreglers mit Luft ist unzulässig  
*Operation with air is not allowed*



## Fuel Pressure Regulator Mini A

Pressure ranges: 2,2 ... 3,5 bar/3,5 ... 5 bar



Mechanical data	
Supply	24,6 mm, O-ring
Reflow	9,15 mm, O-ring
Reflow quantity	min. 15 l/h, max. 220 l/h
Weight	58 g

Description	
Light weight aluminium housing	
No manifold connection	

Accessories	
Pre-filter	1 287 431 008

Part numbers	
2,2 ... 3,5 bar	B 280 550 340
3,5 ... 5 bar	B 280 550 341
Offer drawing	A 280 550 340

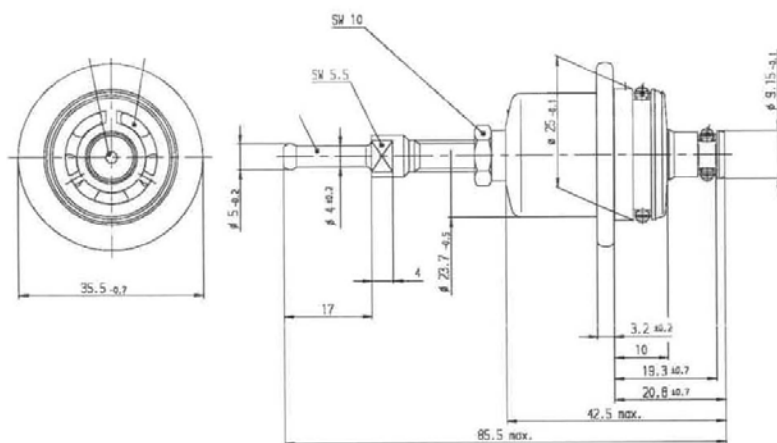

### Erledigung durch Kunden Effect by customer

- O-Ringe leicht mit sauberem Motorenöl einölen  
*Oil O-rings lightly with clean engine oil*
- Nach der Montage an Kraftstoffzuteiler ist Dichtheitsprüfung durchzuführen  
*Leaktest after installation*
- Bei Ausbau und Wiederverwendung des Druckreglers müssen die O-Ringe überprüft werden  
*When the pressure regulator is removed and will be reused, the O-rings must be checked*
- Betrieb des Druckreglers mit Luft ist unzulässig  
*Operation with air is not allowed*



# Fuel Pressure Regulator Mini 38

Pressure range: 3,8 bar



Mechanical data	
Supply	24,6 mm, O-ring
Reflow	9,15 mm, O-ring
Reflow quantity	min. 15 l/h, max. 220 l/h
Set pressure	380 kPa
Set pressure accuracy	2 %
Linearity	1 %
External leak	no fuel leakage at 500 kPa
Bust pressure	> 1500 kPa

Conditions for use	
Temperature range	-40 ... 120° C
Vibration	< 600 m/s <sup>2</sup>
Weight	45 g

Part number	
	<b>0 280 160 616</b>
Offer drawing	<b>A 280 160 616</b>

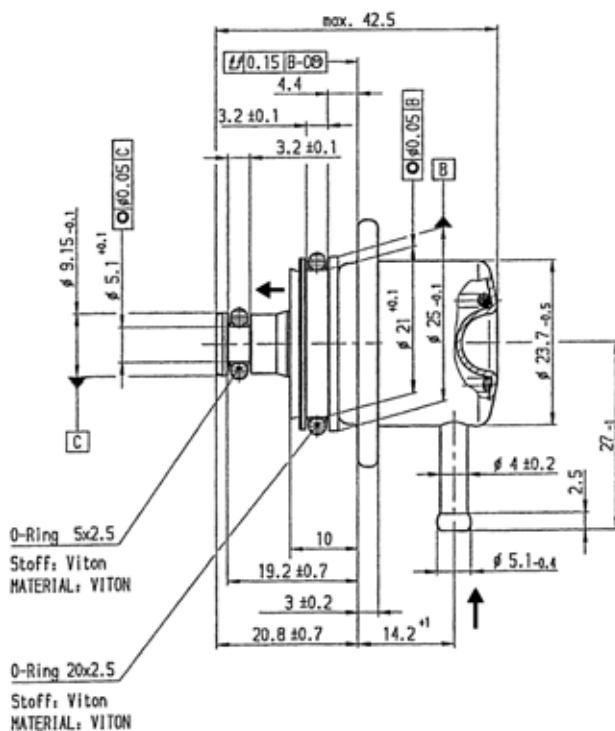

## Erledigung durch Kunden Effect by customer

- O-Ringe leicht mit sauberem Motorenöl einölen  
*Oil O-rings lightly with clean engine oil*
- Nach der Montage an Kraftstoffzuteiler ist Dichtheitsprüfung durchzuführen  
*Leaktest after installation*
- Bei Ausbau und Wiederverwendung des Druckreglers müssen die O-Ringe überprüft werden  
*When the pressure regulator is removed and will be reused, the O-rings must be checked*
- Betrieb des Druckreglers mit Luft ist unzulässig  
*Operation with air is not allowed*

# Fuel Pressure Regulator Mini 50

Pressure range: 5,0 bar



Mechanical data	
Supply	24,6 mm, O-ring
Reflow	9,15 mm, O-ring
Reflow quantity	min. 15 l/h, max. 220 l/h
Set pressure	500 kPa
Set pressure accuracy	2 %
Linearity	1 %
External leak	no fuel leakage at 500 kPa
Bust pressure	> 1500 kPa

Description	
Sheet steel housing with manifold connection	

Part number	
	<b>B 280 550 113</b>
Offer drawing	<b>A 280 550 058</b>

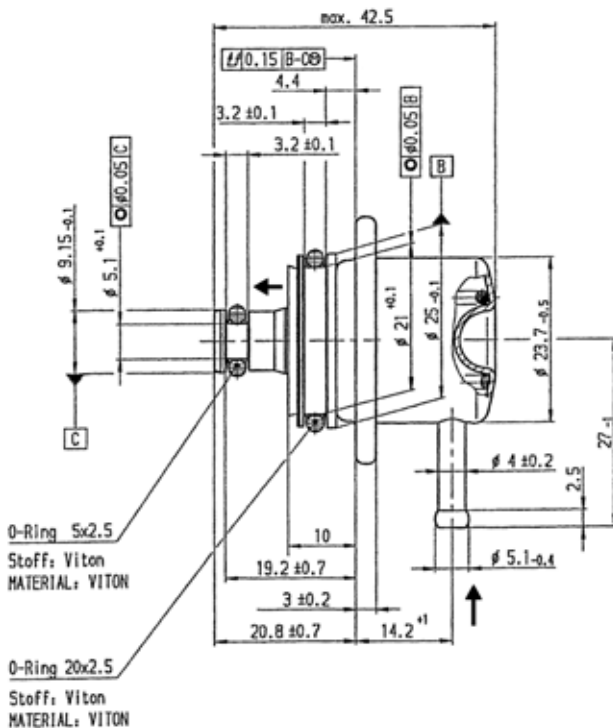

## Erledigung durch Kunden Effect by customer

- O-Ringe leicht mit sauberem Motorenöl einölen  
*Oil O-rings lightly with clean engine oil*
- Nach der Montage an Kraftstoffzuteiler ist Dichtheitsprüfung durchzuführen  
*Leaktest after installation*
- Bei Ausbau und Wiederverwendung des Druckreglers müssen die O-Ringe überprüft werden  
*When the pressure regulator is removed and will be reused, the O-rings must be checked*
- Betrieb des Druckreglers mit Luft ist unzulässig  
*Operation with air is not allowed*

## HPI Control Valve DSV

The DSV is especially designed for regulation of pressure in the common rail of high pressure injection systems.



Mechanical data	
Pressure range	4 ...120 bar
Back pressure	4 bar
Flow quantity	max. 100 l/h
Weight	135 g
Size	32 x 54 x 56 mm
Housing	Aluminium
Operating temperature	-20 ... 130 °C
Max. temperature of location	140°C (max. 5 min)

Electrical data	
Operation voltage	6,5 ... 18 V
Operation current	$I_{\max} = 1,8 \text{ A}$

Part number	
HPI Control Valve DSV	<b>B 261 209 568</b>



## Starter 1,7 kW

This starter is specially constructed for motorsport demand. It is a pre-engaged drive starter, we offer it in clockwise and anticlockwise version on request.



Mechanical data	
Weight	3700 g
Revolutions	3600 x 1/min
Transmission ratio	i 5,0
Modul	2/11

Electrical data	
Performance	1,7 kW

Part number	
	<b>B 261 208 186</b>
Offer drawing	<b>A 261 208 186</b>

Conditions for use	
Max. temperature	150°C
Vibration	high protection

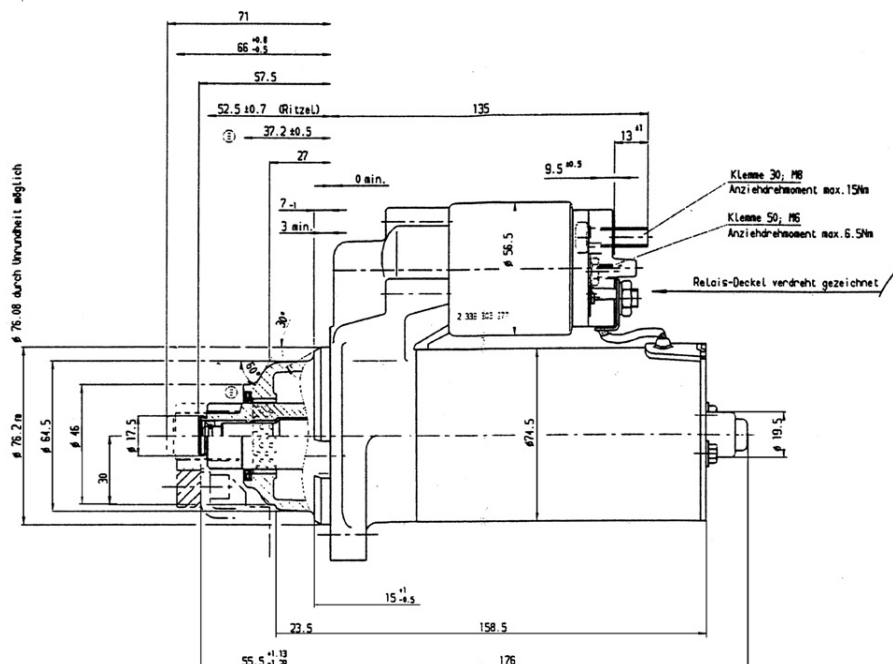

Further special versions on request.

## Starter 2,0 kW

This starter is specially constructed for motorsport demand. It is a pre-engaged drive starter, we offer it in clockwise version.



Mechanical data	
Weight	4050 g
Revolutions	4700 x 1/min
Transmission ratio	i 5,0
Modul	2/11

Conditions for use	
Max. temperature	150°C
Vibration	high protection

Electrical data	
Performance	2,0 kW

Part number	
	<b>B 001 116 174</b>
Offer drawing	<b>A 001 116 174</b>

# Alternators

## Alternator 90 A

This alternator is modified for motorsport demand. It is a clockwise rotation type and is series part in the Porsche Cup cars. We deliver the alternator inclusive fan and pulley. Modifications are available on request.



Mechanical data	
Case material	aluminium
Weight	5400 g
Current regulator unit	integrated
Rotation	clockwise
Max. rotations	17500 x 1/min
Dimensions	
Diameter	143 mm
Length without shaft stub	144 mm
Between mounting points	157 mm

Conditions for use	
Temperature range	-10 ... 90°C
Vibration	high protection
Installation without rubber mounting	

Electric connections	
Battery B+	M8
Control lamp D+	flat-pin connector, see drawing

Electrical data	
Rated current	90 A
Supply voltage	14 V
Cut-in speed	1300 x 1/min
Coupling	screws

Part numbers	
Alternator 90 A	<b>B 120 416 264</b>

### Characteristic

rpm	IG (A) 25°C
1000	0
1300	15,5
1500	32,5
1700	44,8
2000	58,5
3000	76,0
4000	85,0
5000	88,5
6000	90,0
7000	90,3
8000	90,5
9000	90,5
10000	90,5
15000	90,5
20000	90,5

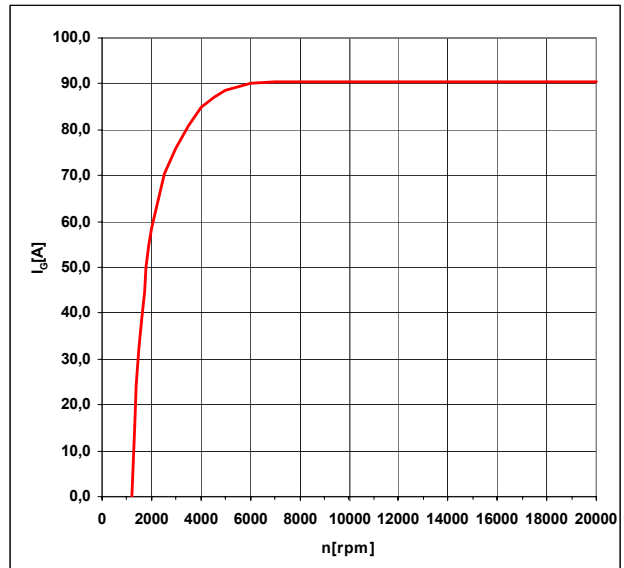

### Design

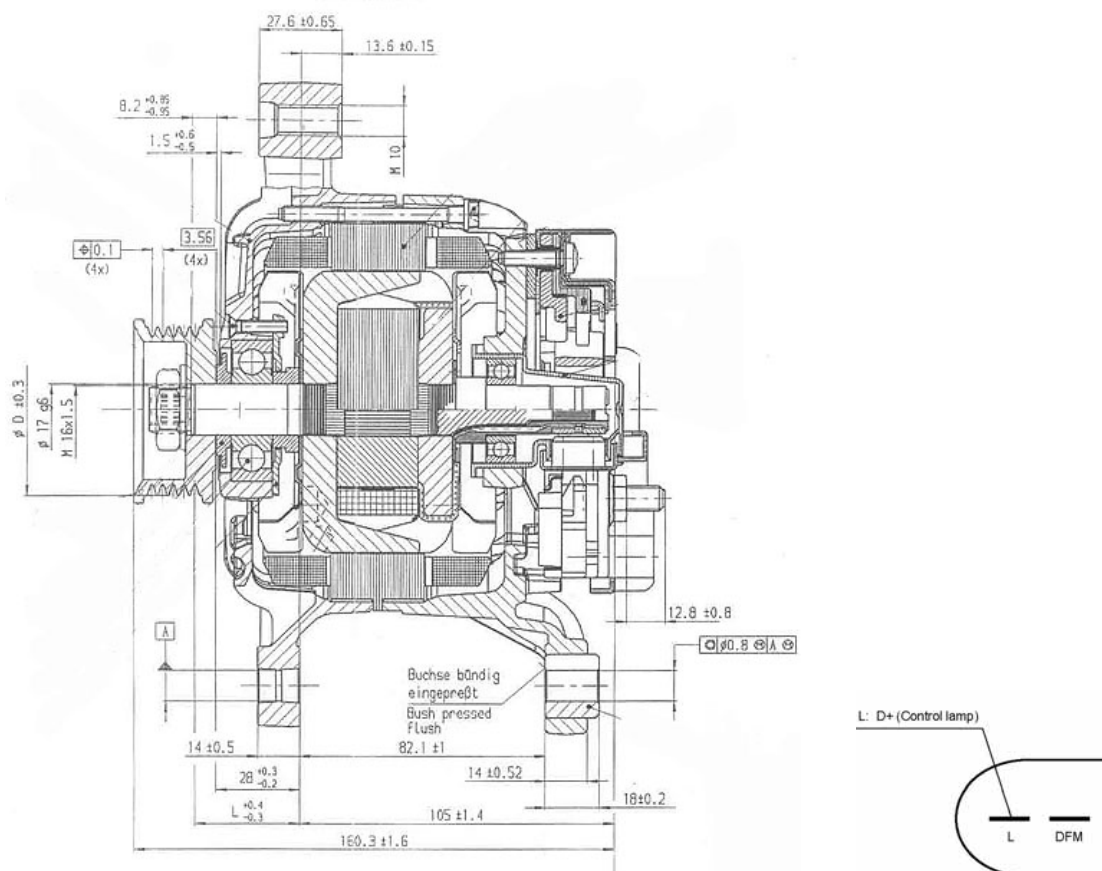



# Alternator GCM1

## 110/130/140 A

This alternator is modified for motorsport demand and splash protected. The stator windings are handmade; the rotor is extra fine balanced. Clockwise and anticlockwise versions are possible, modifications are available on request.



Mechanical data	
Case material	aluminium
Weight	3400 g
Current regulator unit	integrated
Max. rotations	18 000 x 1/min
Dimensions	
Diameter	108 mm
Length without shaft stub	128 mm
Distance between mounting points	154 mm

Conditions for use	
Temperature range	-30 ... 90°C
Vibration	high protection
Installation without rubber mounting	

Electric connections	
Battery B+	M6
Control lamp D+	flat-pin connector, see drawing

Electrical data	
Rated current	110/130/140 A
Supply voltage	13,5 V
Cut-in speed	3000 x 1/min
Coupling	screws

Part numbers	
<b>110 A</b>	
Anticlockwise rotation	<b>B 261 208 606</b>
Clockwise rotation	<b>B 261 208 607</b>
<b>130 A</b>	
Anticlockwise rotation	<b>B 261 208 604</b>
Clockwise rotation	<b>B 261 208 605</b>
<b>140 A</b>	
Anticlockwise rotation	<b>B 261 208 602</b>
Clockwise rotation	<b>B 261 208 603</b>
Offer drawing	
	<b>0 124 OAD 32A</b>

### Characteristic 110 A

Rpm	IG (A) at 90°C
2000	0
2500	13
3000	37
3500	54
4000	65
5000	78
6000	88
7000	96
8000	102
9000	105
10000	108
12000	113
15000	117
18000	120

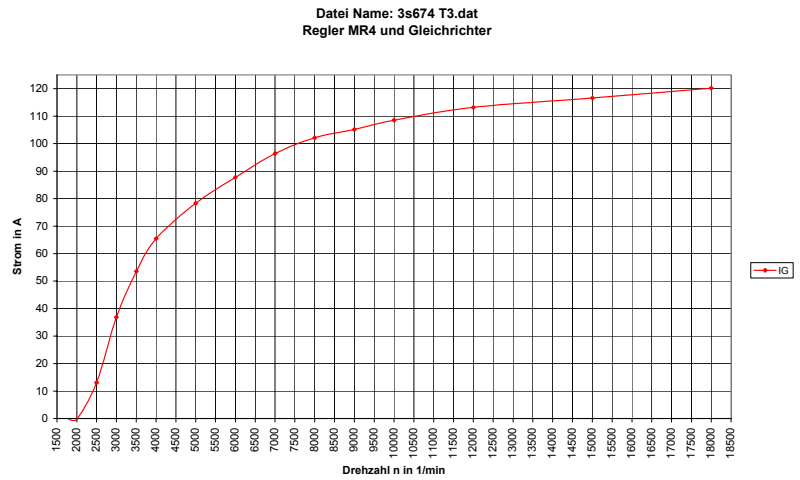

### Characteristic 130 A

Rpm	IG (A) at 90°C
2000	0
2500	6
3000	32
3500	51
4000	63
5000	80
6000	90
7000	98
8000	105
9000	111
10000	116
12000	121
15000	127
18000	131

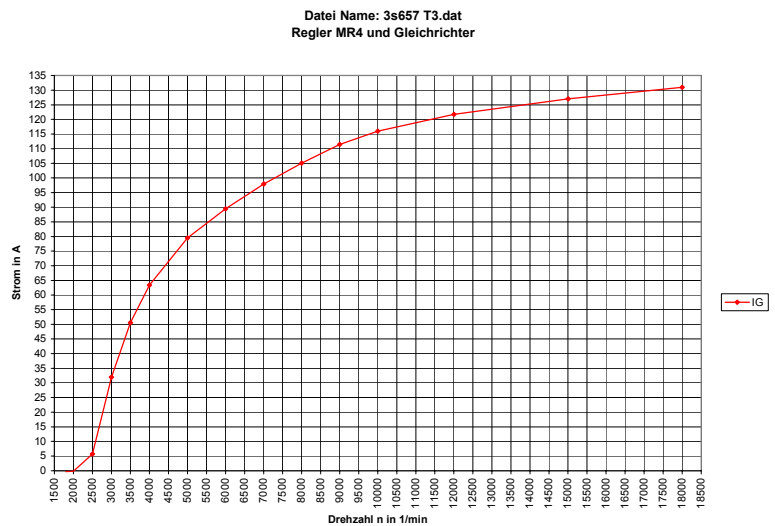



## Alternator F1-01

This alternator with permanent excitation is modified for motorsport demand and splash fluid protected. The stator windings are hand made. The rotor is extra fine balanced and designed for high rotation speed operation. Clockwise and anti-clockwise versions are available while modifications are available on request.



Mechanical data	
Weight	890 g
Voltage regulator unit	external; separately available
Max. rotation speed	28 000 x 1/min
Cooling options	water/oil/air
Dimensions	
Diameter	73 mm
Length	75 mm
Conditions for use	
Temperature range	- 10°C ... 180°C
Installation	mounting flange

Electrical connections	
Cable harness with bare wires.	
Broad connector range available. Mounting on request.	

Electrical rating (with external voltage regulator unit)	
Rated current	56 A
Output voltage	14,2 V
Power output @10000 rpm	max. 800 W

Part number	
<b>F01E B01 861</b>	
Please specify rotation direction, cooling option and connector choice when ordering	

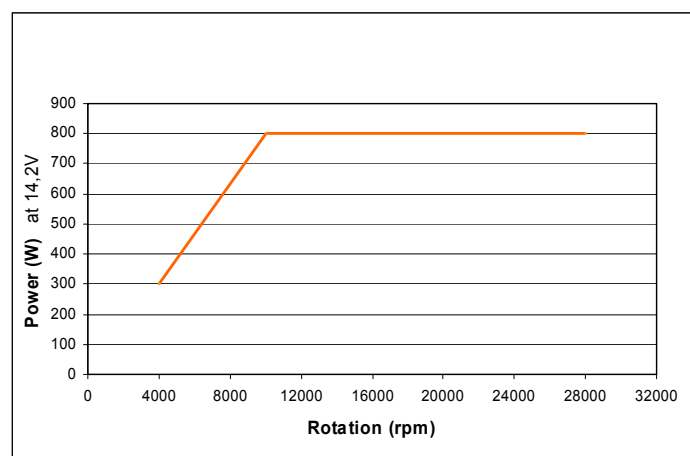

## Alternator F1-02

This alternator with permanent excitation is modified for motorsport demand and splash fluid protected. The stator windings are hand made. The rotor is extra fine balanced and designed for high rotation speed operation. Clockwise and anti-clockwise versions are available while modifications are available on request.



### Mechanical data

Weight	1190 g
Voltage regulator unit	external; separately available
Max. rotation speed	28 000 x 1/min
Cooling options	water/oil/air

### Dimensions

Diameter	73 mm
Length	87 mm

### Conditions for use

Temperature range	- 10°C ... 160°C
Installation	mounting flange

### Electrical connections

Cable harness with bare wires.  
Broad connector range available. Mounting on request.

### Electrical Rating

(with external voltage regulator unit)

Rated current	74 A
Output voltage	14,2 V
Power Output @10000 rpm	max. 1050 W

### Part number

**F01E B01 862**

Please specify rotation direction, cooling option and connector choice when ordering

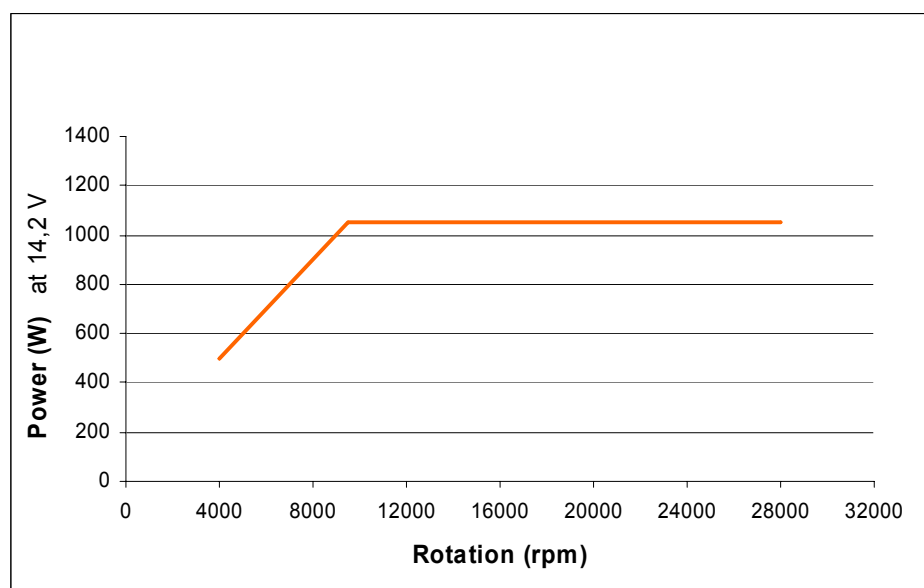

## Alternator F1-03

This alternator with permanent excitation is modified for motorsport demand and splash fluid protected. The stator windings are hand made. The rotor is extra fine balanced and designed for high rotation speed operation. Clockwise and anti-clockwise versions are available while modifications are available on request.



### Mechanical data

Weight	1740 g
Voltage regulator unit	external; separately available
Max. rotation speed	19 000 x 1/min
Cooling options	water/oil/air

### Dimensions

Diameter	73 mm
Length	97 mm

### Conditions for use

Temperature range	- 10°C ... 160°C
Installation	mounting flange

### Electrical connections

Cable harness with bare wires.  
Broad connector range available. Mounting on request

### Electrical Rating

(with external voltage regulator unit)

Rated current	74 A
Output voltage	14,2 V
Power output @8000 rpm	max. 1050 W

### Part number

**F01E B01 863**

Please specify rotation direction, cooling option and connector choice when ordering

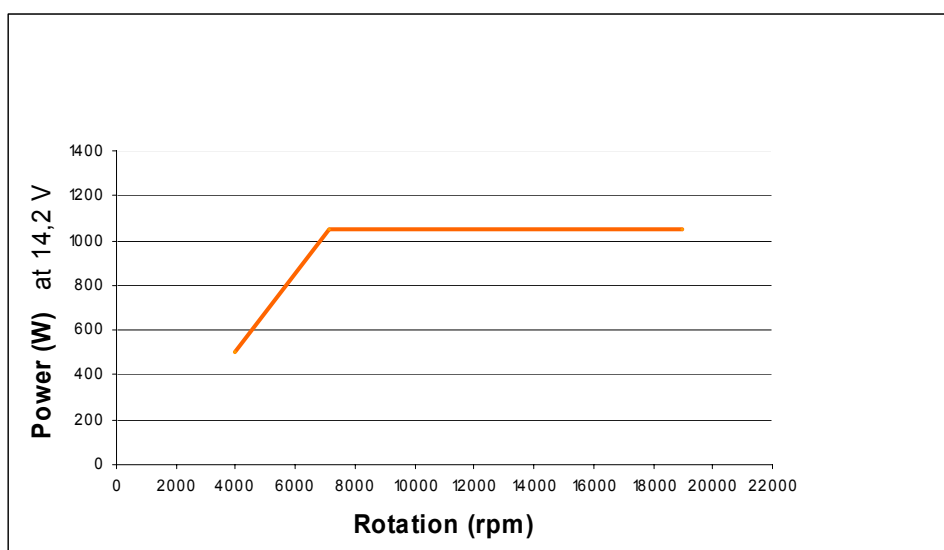

# Relay

## Relay 25 A

A miniature DC-contactor for electrical power control. The rated current is 25 A for secondary power distribution with high inrush current like hydraulic- and fuel motor loads. The base part allows a quick change of the relay.

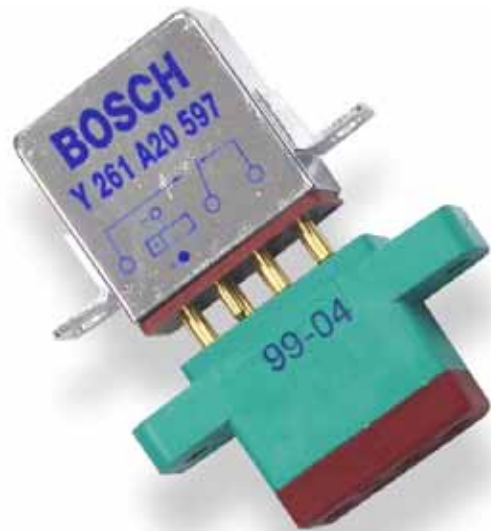

Mechanical data	
Drill hole	3,1 mm
Weight	61 g

Conditions for use	
Temperature range	-30 ... 125 °C
Vibration	30 g/70 Hz ... 3 kHz
Shock	100 g (11 ms)

Electrical data	
Supply voltage	12 ... 14,5 V
Max. current	25 A
Min. switches	20 000

Part numbers	
Relay	Y 261 A20 597
Base	Y 261 A20 598

# Switches

## Switches

We offer a wide range of switches for the special demands of motorsport.

You can combine all types with every design and every connector cable equivalent to your individual requirement.

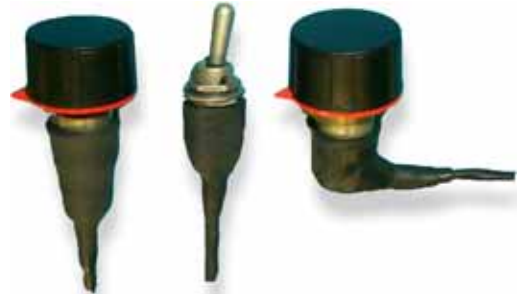

Type
For MAP Function
For display-toggle-function
3 steps for MAP-function
4 steps
4 steps for MAP-function
6 steps for display switch over
12 steps
Connector cables
Without
KPTA 6E6-4P-C-DN
KPTC 6E8-3P-C-DN
ASL 6-06-05PN-HE

Extras
With integrated resistor network
Lockable
Variable number of steps
Variable form of rotary waver switch
Without end stop
Application range
Motor functions
Dashboard functions
Display switch over
Display dimmer
Design
Straight
90° angled

Part numbers			
Model	Design	Connector	
12 steps	Straight	KPTC 6E8-3P-C-DN	<b>B 261 209 143</b>
12 steps	90° angled	KPTC 6E8-3P-C-DN	<b>B 261 209 144</b>
12 steps	straight	KPTC 6E6-4P-C-DN	<b>B 261 209 146</b>
4 steps	straight	KPTC 6E6-4P-C-DN	<b>B 261 209 147</b>
12 steps without	straight	KPTC 6E6-4P-C-DN	<b>B 261 209 148</b>
4 steps LED dimmer display		KPTC 6E8-3P-C-DN	<b>B 261 209 527 01</b>
4 steps display dimmer DDU		KPTC 6E8-3P-C-DN	<b>B 261 209 528</b>
4 steps display dimmer DDU	90° angled	KPTC 6E8-4P-C-DN	<b>B 261 209 630</b>
12 steps	straight	ASL 6-06-05PN-HE	<b>B 261 209 643</b>
for MAP function	straight	ASL 6-06-05PN-HE	<b>B 261 209 644</b>
4 steps display dimmer DDU	straight	ASL 6-06-05PN-HE	<b>B 261 209 646</b>
4 steps LED dimmer DDU	straight	ASL 6-06-05PN-HE	<b>B 261 209 647 01</b>
6 steps display dimmer and switch over DDU	straight	ASL 6-06-05PN-HE	<b>B 261 209 659</b>



# Appendix

# Vibration Profile 1

Broadband noise: 8h/Direction	
Frequency (Hz)	Acceleration density [(m/s <sup>2</sup> ) <sup>2</sup> /Hz]
20	50,4
55	26,0
180	1,0
300	1,0
360	0,56
1.000	0,6
2.000	0,6
Effective Value a <sub>Eff</sub>	55,4 m/s <sup>2</sup>

Sinus: 8h/Direction	
Frequency (Hz)	Acceleration [m/s <sup>2</sup> ]
100	50
180	200
250	200
350	60
2.000	60

## Vibration Profile 2

Broadband noise: 8h/Direction	
Frequency (Hz)	Acceleration density [(m/s <sup>2</sup> ) <sup>2</sup> /Hz]
10	10
50	10
66,7	1
100	1
1.000	0,1
Effective Value a <sub>Eff</sub>	26,9 m/s <sup>2</sup>

## Vibration Profile 3

Sinus		
Alteration rate of frequency: 1 oct./min		
Frequency [Hz]	Amplitude of acceleration [m/s <sup>2</sup> ]	Amplitude of oscillation lane [μm]
20	50	
85	50	
85		175
200		175
200	280	
220	280	
300	125	
440	125	

Broadband noise	
Frequency [Hz]	Acceleration density [(m/s <sup>2</sup> ) <sup>2</sup> /Hz]
10	14,0
50	7,0
60	3,5
300	0,51
500	45,6
1.500	15,26
Effective Value a <sub>Eff</sub>	168 m/s <sup>2</sup>



**Bosch Engineering GmbH  
Motorsport  
An der Bracke 9  
71706 Markgröningen  
Germany**

**Phone: 00 49 (0) 711/811-3981  
Fax: 00 49 (0) 711/811-3982**

**North American Office:  
Bosch Engineering North America  
Motorsport, Dep. BEG/MSD-NA  
38000 Hills Tech Drive  
Farmington Hills, MI 48331-3417  
Phone: 00 1 248 876-2977  
Fax: 00 1 248 876-7373**

**E-mail: [motorsport@bosch.com](mailto:motorsport@bosch.com)  
[www.bosch-motorsport.com](http://www.bosch-motorsport.com)**



**BOSCH**