

Service.



Self-Study Programme 237

Manual gearbox 02T

Design and Function

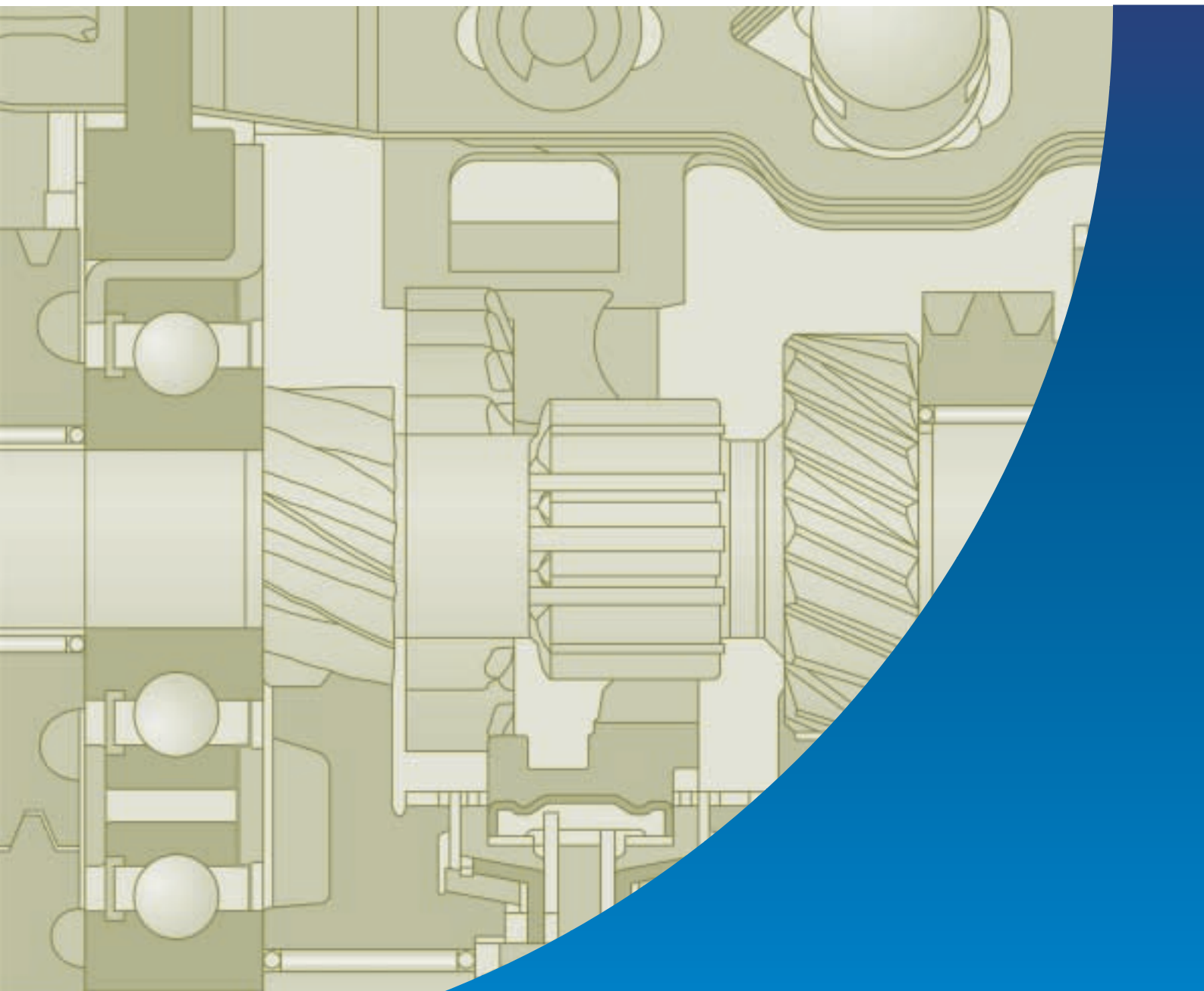

The 02T 5/6-speed manual gearbox

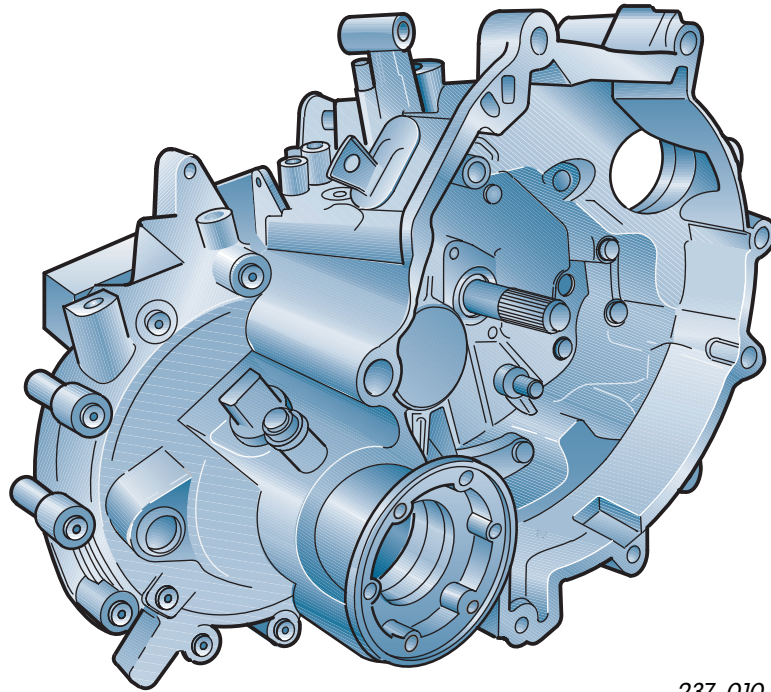

237_010

Gearbox design

With the new 02T 5/6-speed manual gearbox of the MQ200 series, Volkswagen has succeeded in developing an ultra-light twin-shaft gearbox. The housing is manufactured from magnesium. The gearbox can transmit up to 200 Nm of torque and is used throughout the Group in combination with various engines ranging from the A00 class to the A class.

The final drive ratios and the ratios of the individual gears can be matched to the power outputs of the various engines.

The type diversity within the gear and final drive ratios allows an optimum compromise to be found between sporty and economical gearbox design for all automotive applications.

The gearbox is operated by means of selector cables. The clutch control is hydraulic.

The development goals for the new gearbox were as follows:

- Easy and exact gear-changes
- Optimal efficiency
- Low weight
- Modular technology
- Standard cable-operated gearbox

New



Important
Note



**The Self-Study Programme
is not a Workshop Manual!**

Please always refer to the relevant Service Literature for all inspection, adjustment and repair instructions.

Table of contents



| | |
|--------------------------------------|-----------|
| Introduction | 4 |
| Modular system | |
| Gearbox mechanicals | 6 |
| Gearbox design | |
| Input shaft | |
| Output shaft | |
| Bearing support | |
| Double synchronisers | |
| Differential | |
| Force path | |
| Selector mechanism | 16 |
| Outer selector mechanism | |
| Inner gear change mechanism | |
| Selection movement | |
| Shift movement | |
| Reverse gear lock | |
| Service | 22 |
| Sensors | 24 |
| 6-speed-version | 26 |
| Gearbox design | |
| Modifications to the 5-speed version | |
| Force path | |
| Test your knowledge | 30 |



Introduction



The modular system

Individual modules are assembled in modular form. This increases their functionality after assembly in series production and in the service workshop.

The modules are:

Clutch release lever

This module contains the clutch release lever, the release bearing and the guide sleeve.

Selector shaft with selector mechanism cover

All blocking detent, spring and guide elements of the selector mechanism, as well as the angle piece for adjustment of the selector mechanism are accommodated in this module.

The inner selector module

with shift forks, selector plates and bearing.

The bearing support

with the two grooved ball bearings and pre-assembled powertrain and output shaft.

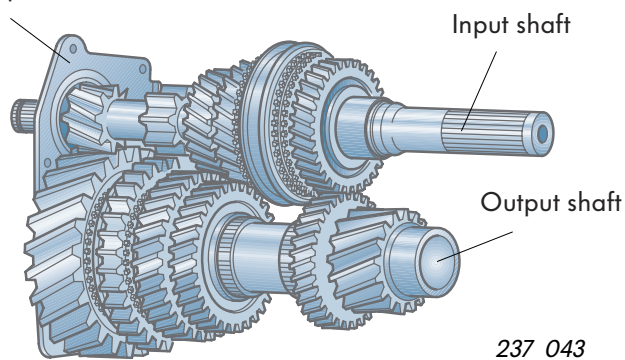
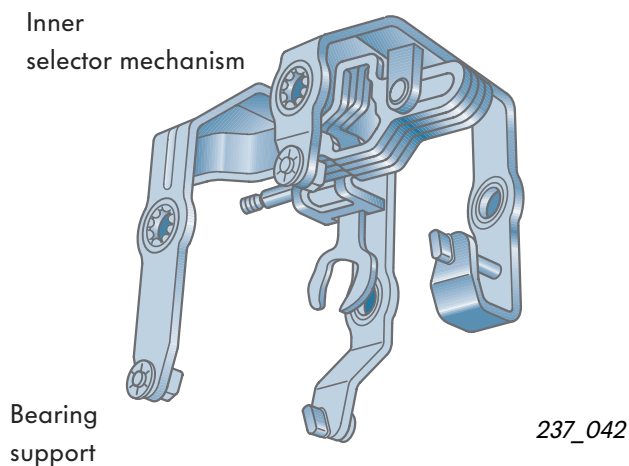
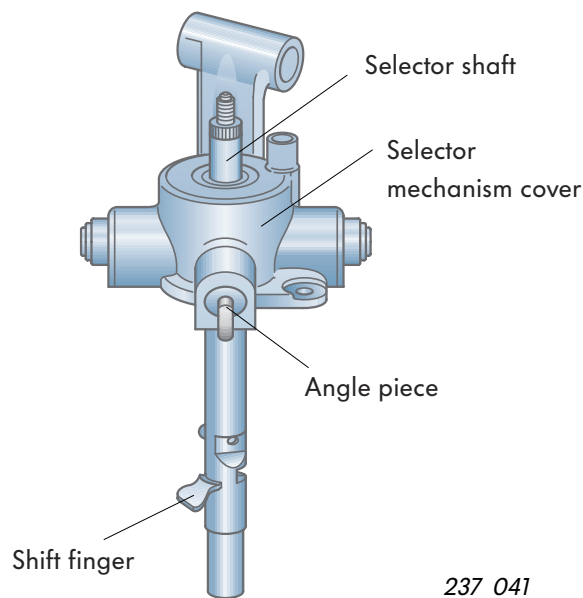
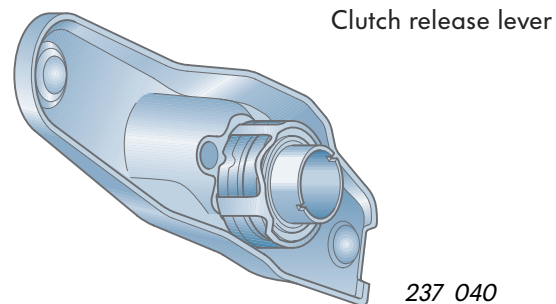



The housing

is made from magnesium and consists of 2 parts (gearbox housing, clutch housing). The gearbox housing is sealed off from the exterior by a cover.

The fixing points for the left assembly mounting bracket are located at the top of the gearbox housing. The attachment points for the self-aligning bearing support are located at the bottom of the gearbox housing.

In comparison with aluminium, magnesium has a lower density and therefore also lower strength. This was compensated for by thicker ribbing and increased wall thickness.

The result is a mass reduction of 2.5 kg compared to the conventional aluminium construction.



The lower material density of the housing necessitates increased bolt screw-in depths.

To protect the housing against electrochemical degradation, the bolts are coated (see SSP 192, page 36/37).

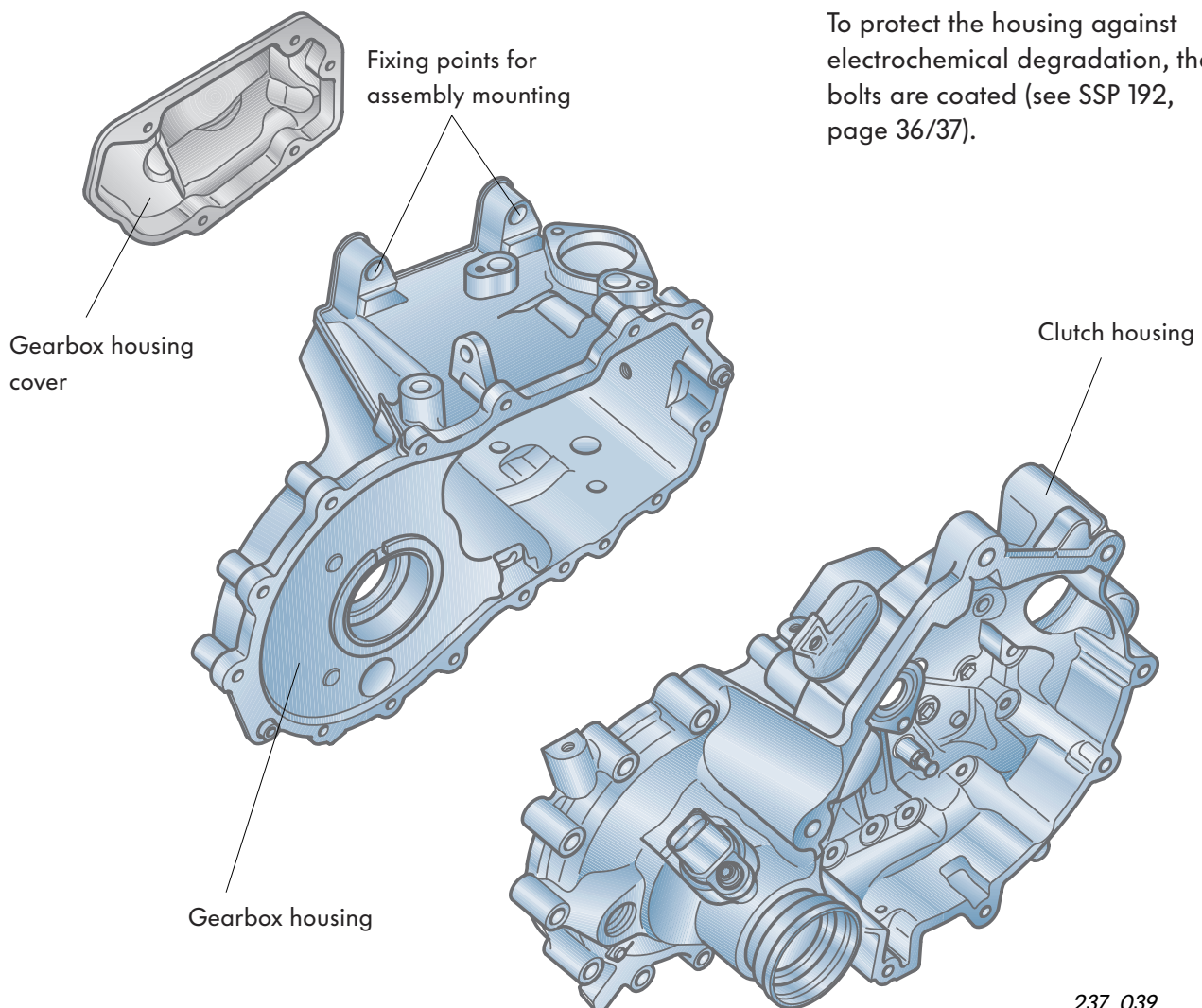

237_039

Gearbox mechanicals

Gearbox design

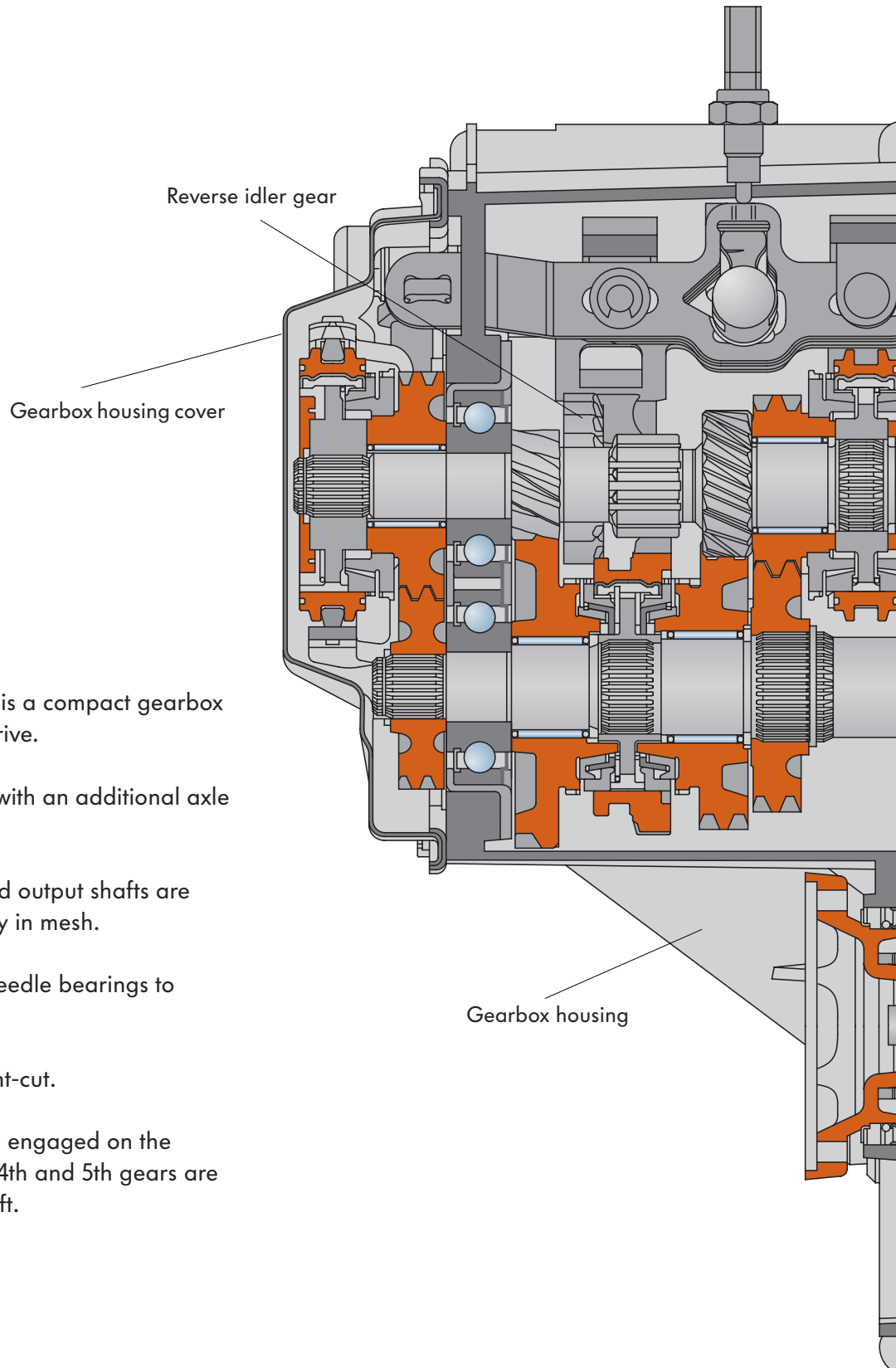

The O2T manual gearbox is a compact gearbox for 5-speed front wheel drive.

It is a twin-shaft gearbox with an additional axle for reverse gear.

The gears on the input and output shafts are helical-cut and continuously in mesh.

All change gears run in needle bearings to maximise smoothness.

The reverse gear is straight-cut.

The 1st and 2nd gears are engaged on the output shaft and the 3rd, 4th and 5th gears are engaged on the input shaft.

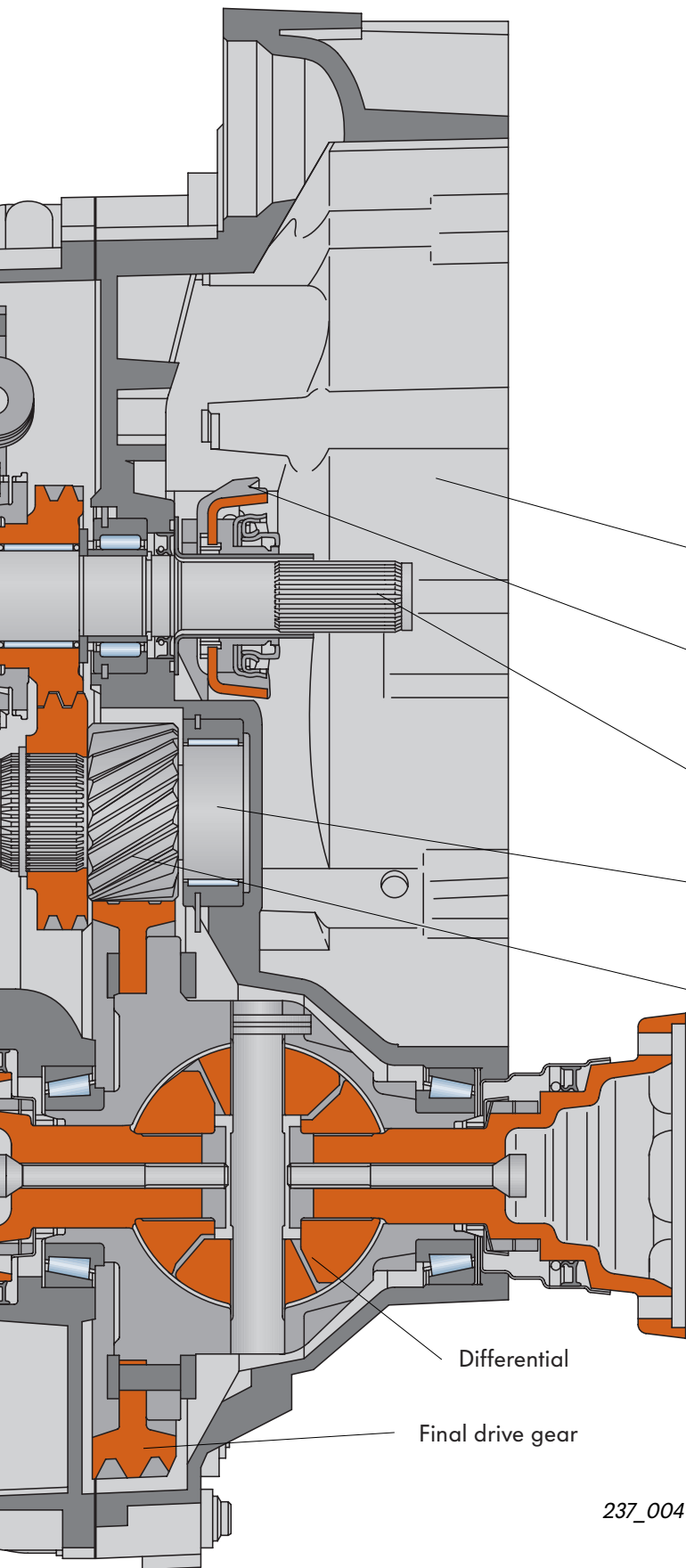

When reverse gear is selected, the reverse idler gear is engaged on a separate shaft between the input and output shaft, and the direction of rotation the output shaft is changed.

All forward gears are synchronised. 1st and 2nd gears have double synchronisers.

Torque is transmitted to the final drive gear, and therefore also to the differential, via the output shaft gear.

Clutch housing

Clutch release lever

Input shaft

Output shaft

Output shaft gear

Differential

Final drive gear

237_004



Gearbox mechanism

The input shaft

is mounted in a bearing assembly in the gearbox housing together with a cylindrical roller bearing in the clutch housing (loose bearing) and with a grooved ball bearing (fixed bearing).

For mass reduction, the input shaft has a deep bore.

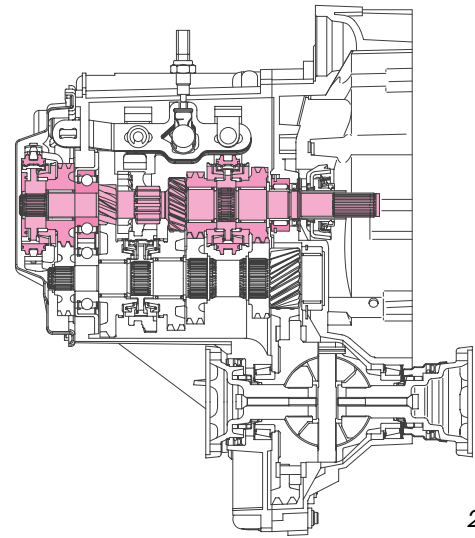

237_031

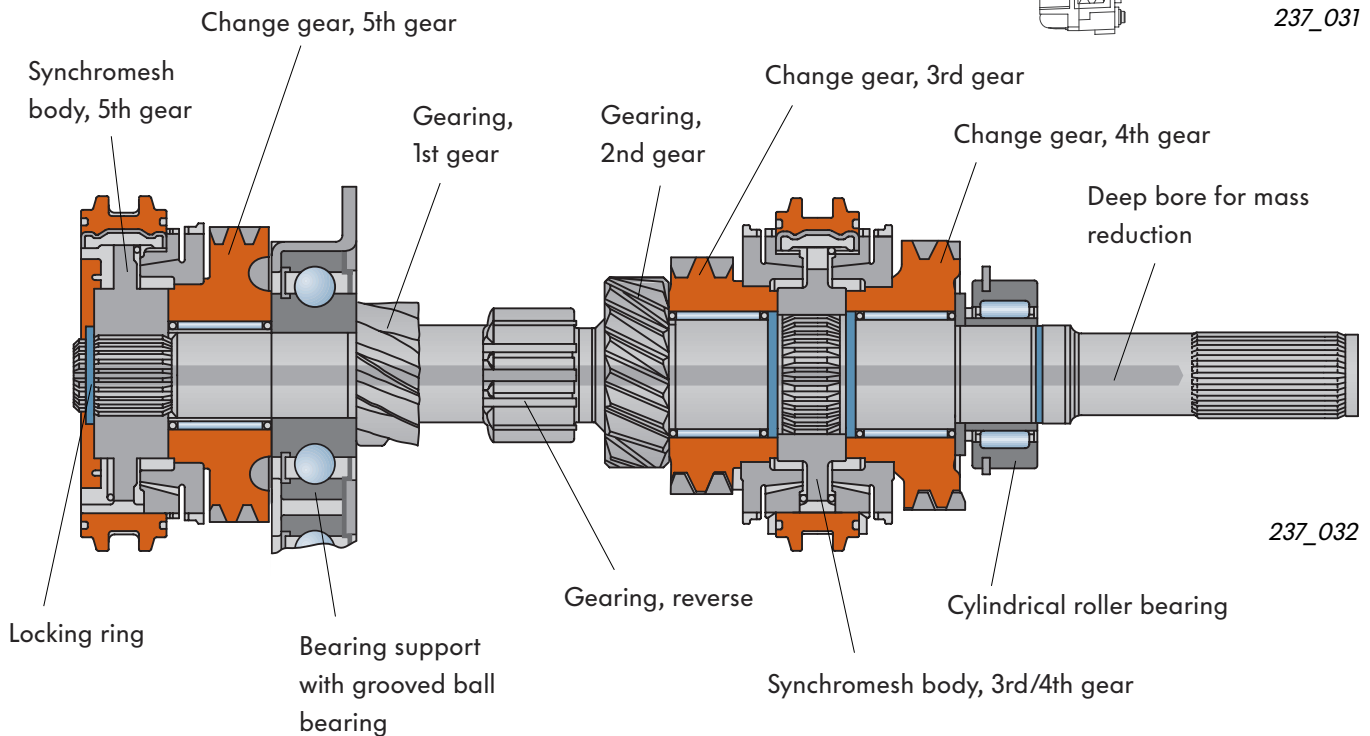

237_032

The 1st, 2nd and reverse gear wheels are connected positively to the input shaft.

The 3rd, 4th and 5th gear wheels are loose and run in needle bearings.

The synchromesh body of 3rd/4th gear and 5th gear are connected positively to the input shaft via a longitudinal grooved spline.

After one of the gears is engaged, the corresponding "idler gear" is also connected to the input shaft.

Locking rings hold the gears in position.

The output shaft

has a fixed / idler bearing.

As with the input shaft, the output shaft runs in bearings in the gearbox housing

- together with a cylindrical roller bearing (idling) in the clutch housing
- together with a grooved ball bearing (fixed) which is mounted together with the input shaft in the bearing assembly.

For mass reduction, the output shaft is hollow-drilled.

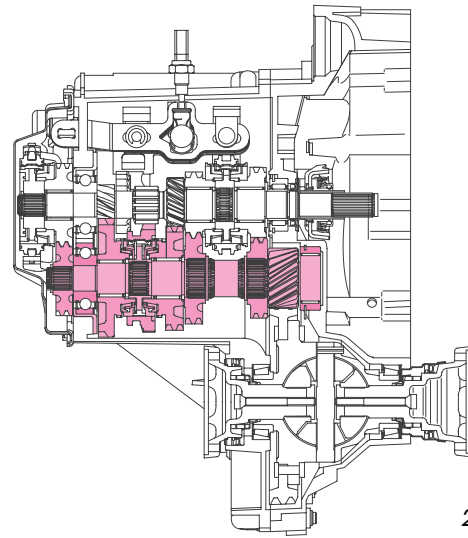

237_033

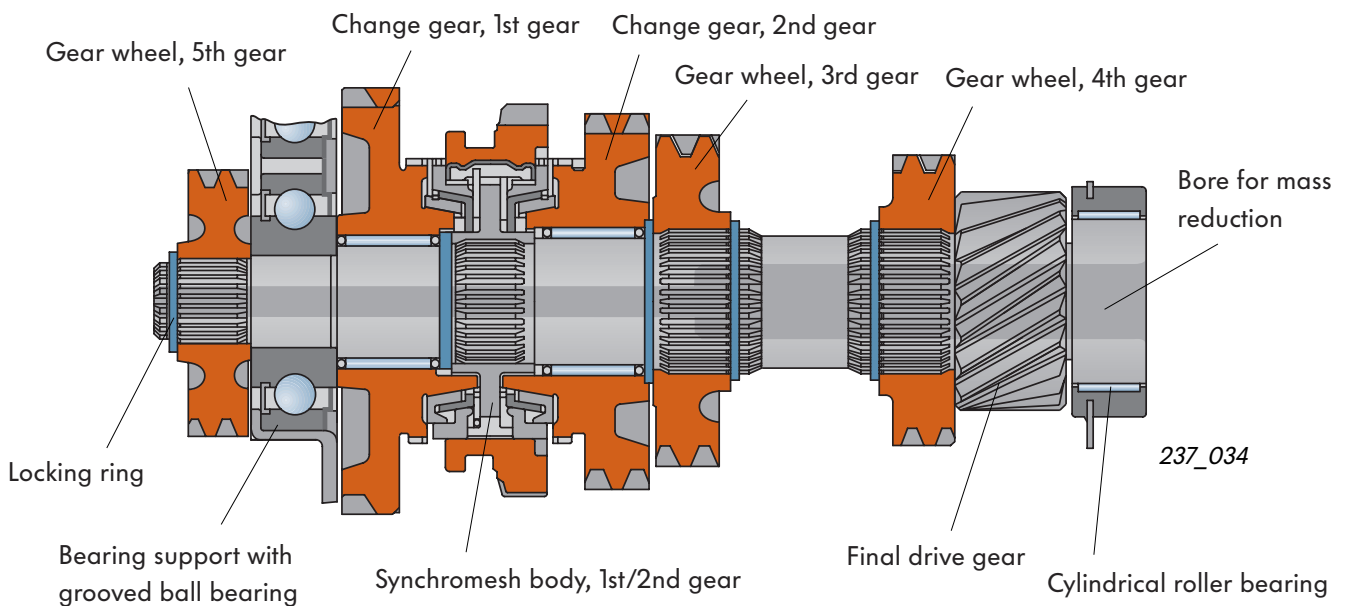

237_034

The 3rd, 4th and 5th gear wheels and the synchromesh body for 1st/2nd gear are positively connected to the output shaft in the direction of rotation by means of close-spaced gear teeth.

Locking rings hold the gears in position.

The 1st and 2nd gear wheels are idler gears and run in needle bearings on the output shaft.

Gearbox mechanism

The bearing support

The modular design is a new feature of the gearbox layout.

A module of this type is the bearing support with the two grooved ball bearings.

The grooved ball bearings are not mounted directly in the gearbox housing, they are seated in a separate bearing support.

New

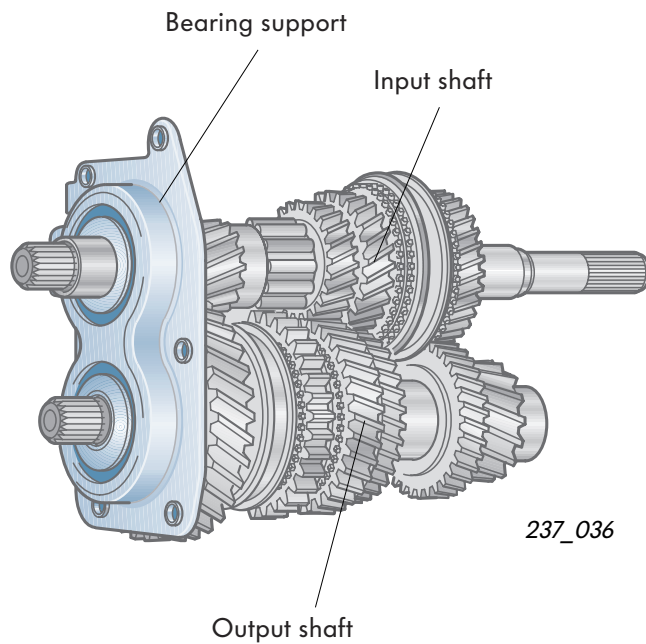
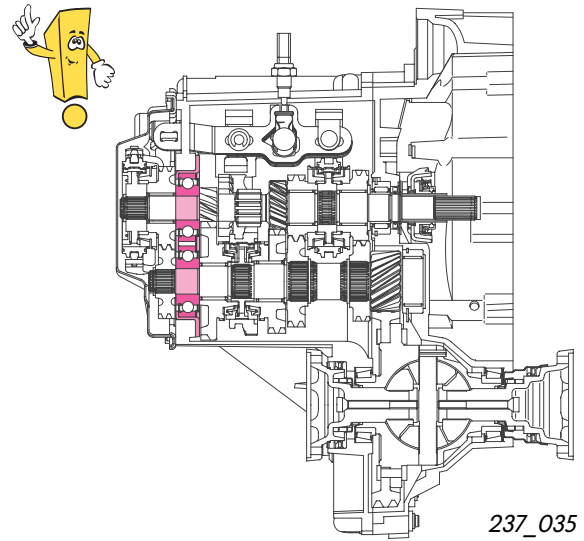

The complete shaft and gear packet of the input and output shaft is pre-assembled outside the gearbox housing in the bearing support and, thus, can easily be installed in the gearbox housing.



For repair work, the bearing support together with the two grooved ball bearings is replaced completely.

See also the instructions in the Workshop Manual.

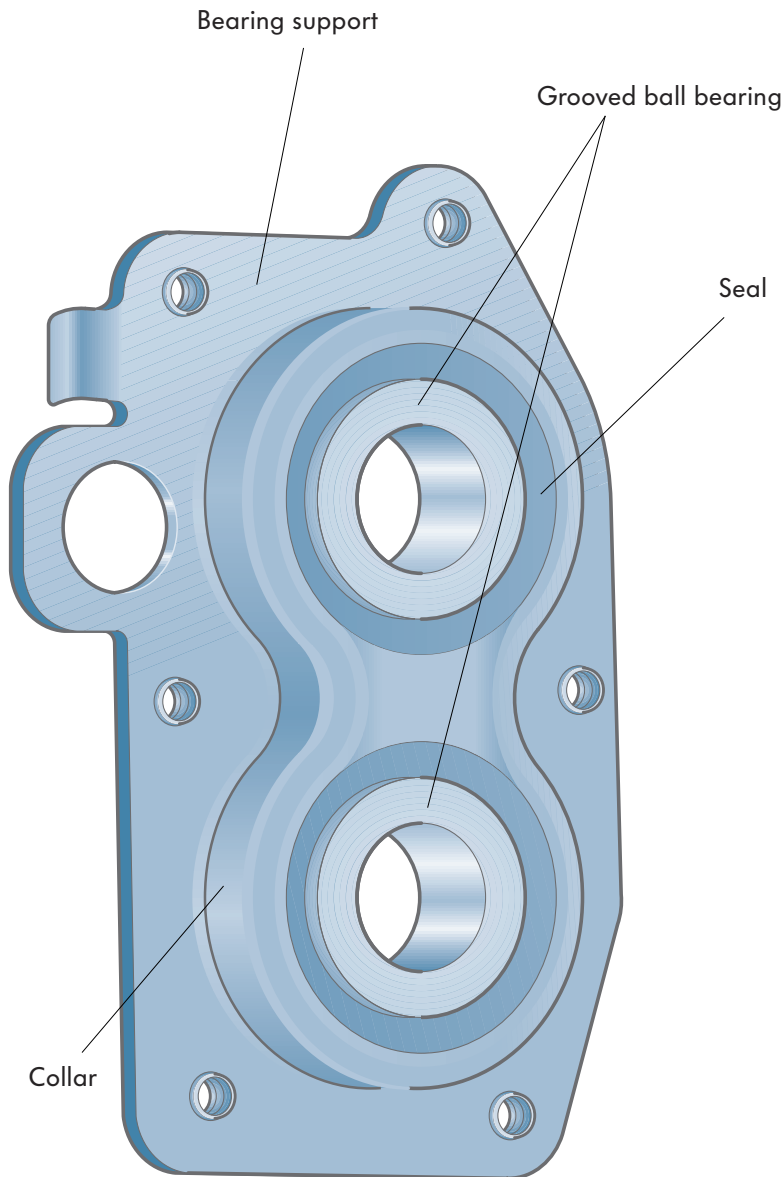

237_037

The two grooved ball bearings for the "fixing" the input and output shafts are an integral part of the compact bearing support and are press-fitted in it.

The grooved ball bearings are located in the design position using a form disk. The form disk is welded onto the bearing support.

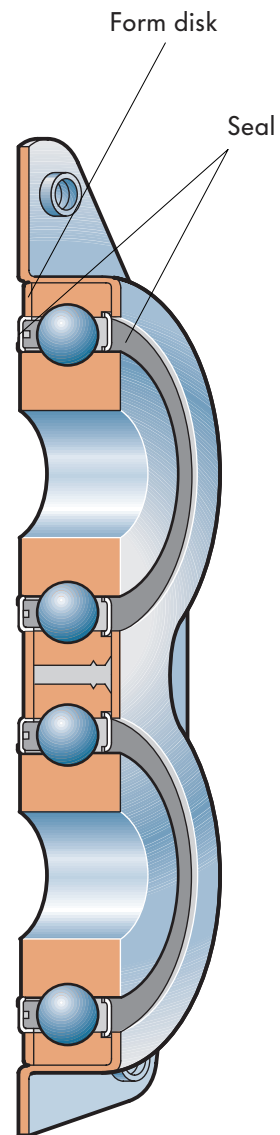

237_038

The grooved ball bearings are protected against abrasion residues in the gearbox oil by separate radial sealing rings.

The bearing support, with its spectacle type collar, is press-fitted in the gearbox housing and secured to the gearbox housing with six bolts.



Gearbox mechanism

Double synchroniser for 1st/2nd gear

Before a gear on the input shaft is engaged with a gear on the output shaft through the synchromesh body and the sliding sleeve, it is first of all necessary to synchronise the gears. The gears are synchronised during the gearshift via a taper on the gear and on the sliding sleeve of the synchromesh body.

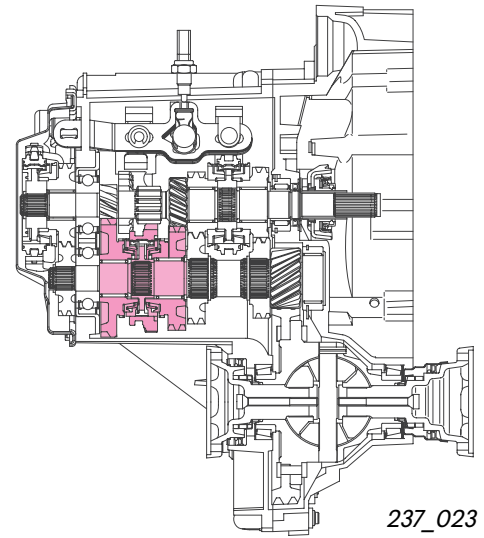
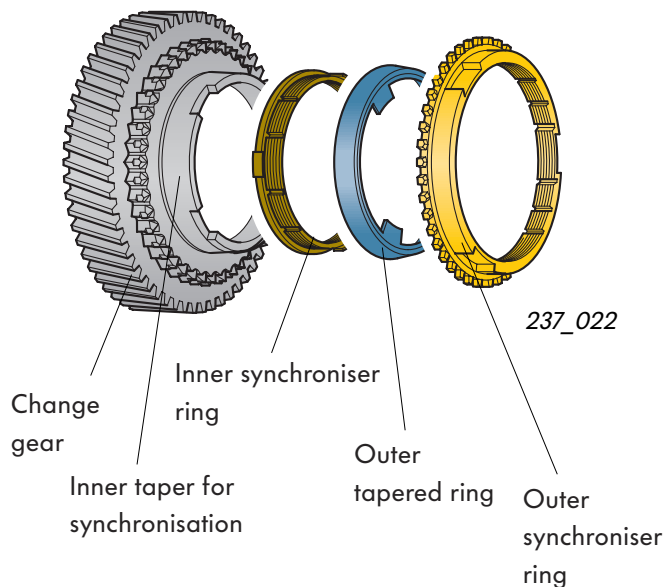
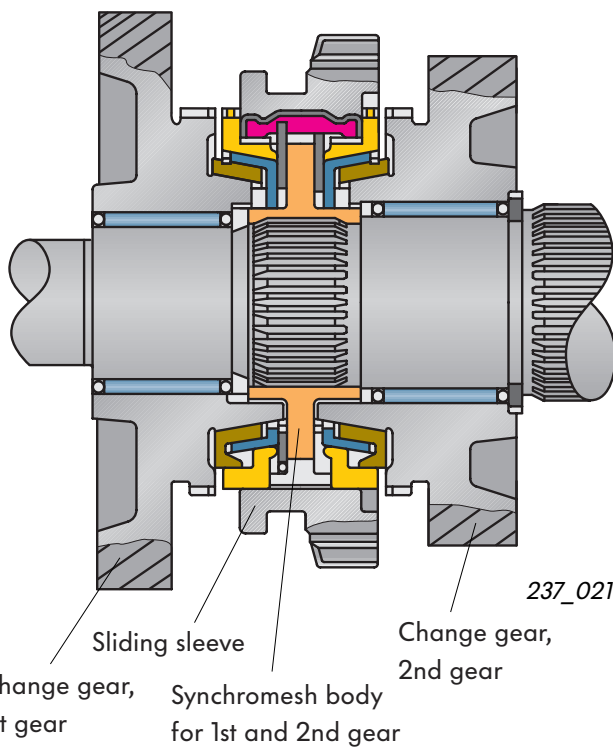

This near-doubling of the area of the tapered friction face increases synchroniser performance by approx. 50 % and almost halves the shifting effort required.

The result is an improvement in operating comfort during down-changes from 3rd gear into 2nd gear and from 2nd into 1st gear.

The double synchronisers for each gear consist of

- a synchroniser ring (inner)
- a tapered ring
- a synchroniser ring (exterior).

The differential

Is combined with the manual gearbox to form a unit.

It is mounted in two optimised tapered roller bearings in the gearbox and clutch housing.

Two oil seals with different diameters seal the housing off from the exterior at the flange shafts.

The final drive gear is riveted to the differential housing and paired with the output shaft gear.

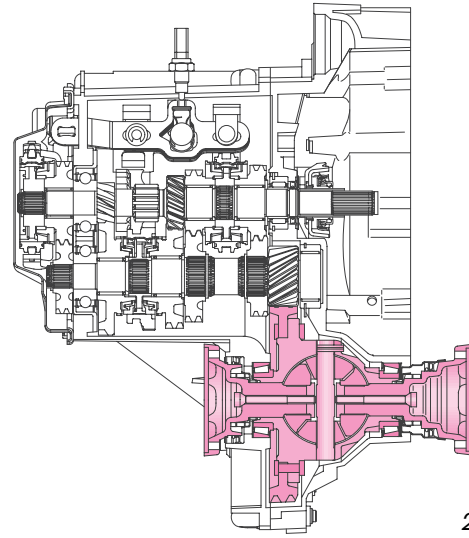

237_027



After replacing components, the differential is required to be readjusted axially in the clutch housing with an adjusting disc. Refer to the relevant Workshop Manual for instructions!

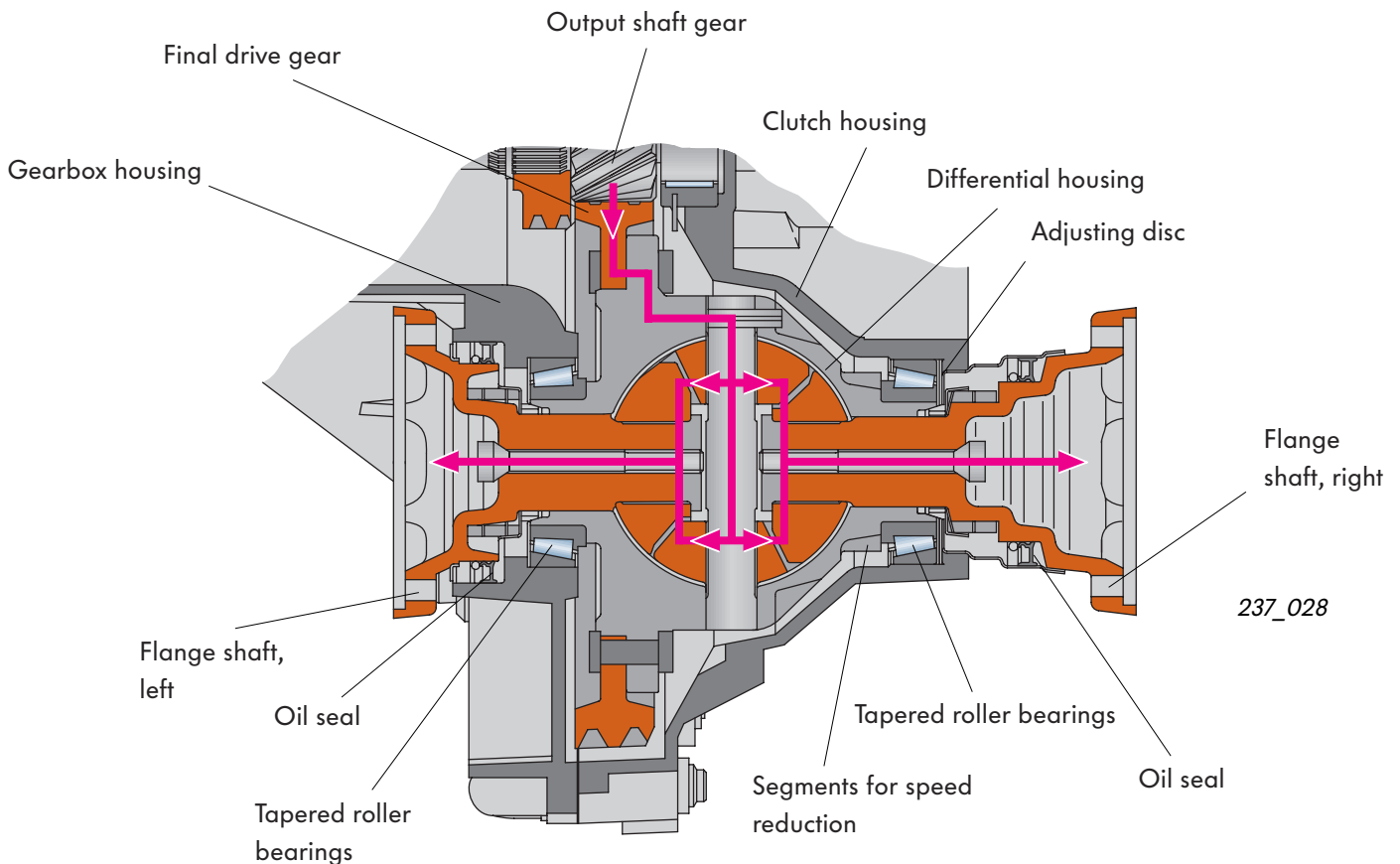

237_028



Gearbox mechanism

Force path

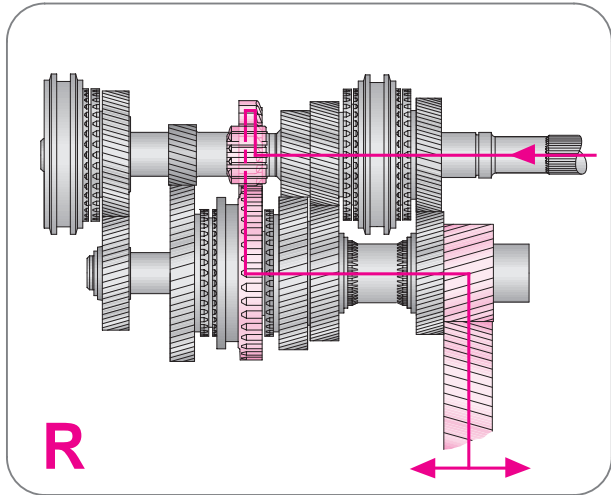

237_011

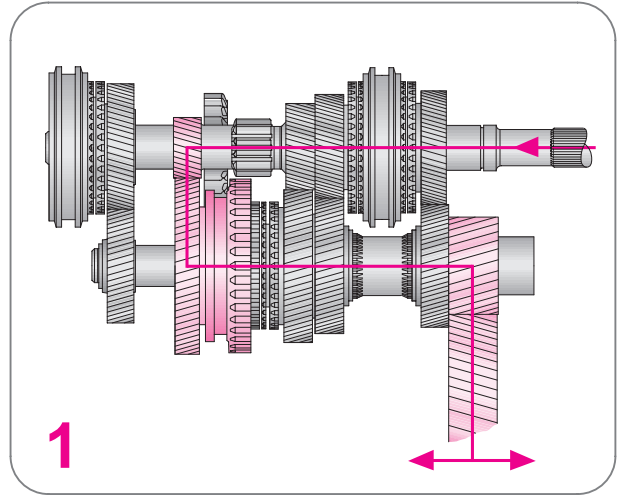

237_005

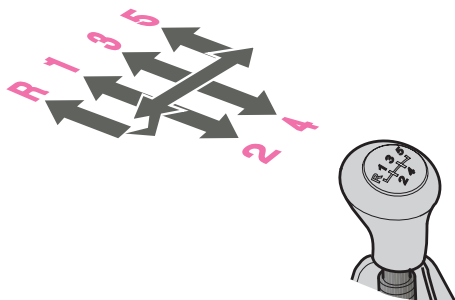

237_019

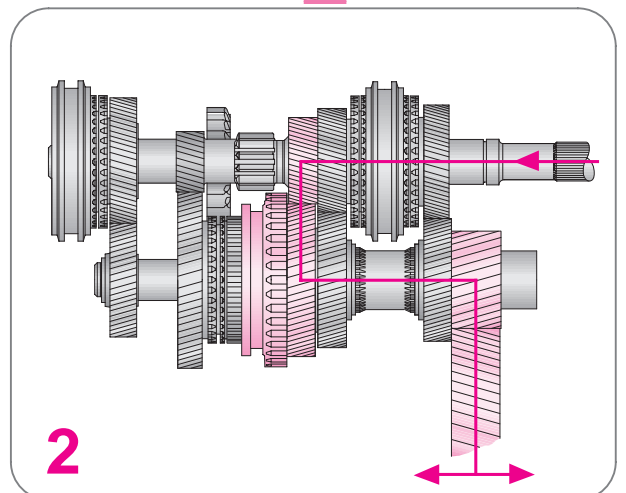

237_006

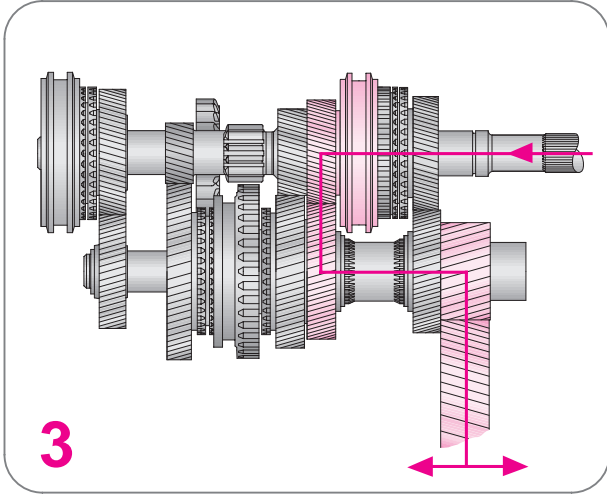

237_007

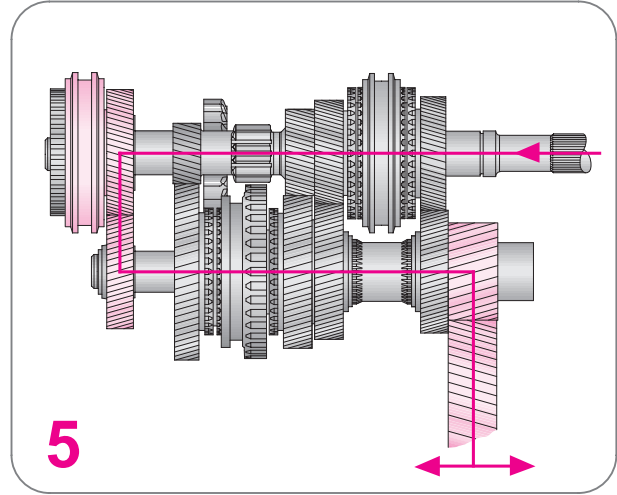

237_009

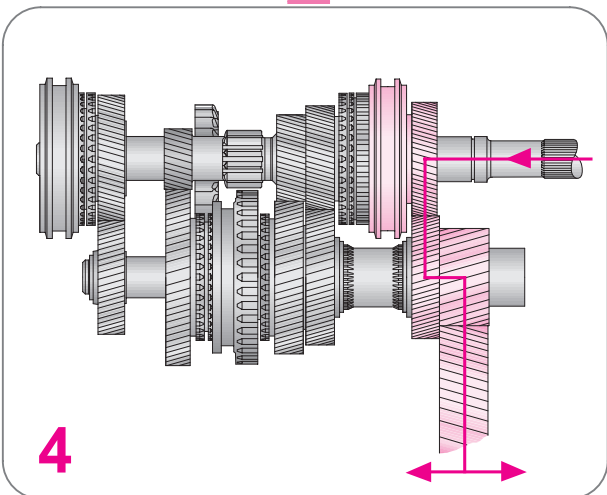

237_008

The force path in the gearbox

Engine torque is transferred to the gearbox via the input shaft.

In accordance with the gear selected, the torque is transferred via the relevant gear pair to the output shaft and from here to the final drive gear and differential.

Torque and engine speed now act on the driven wheels in accordance with the shift position.

Selector mechanism

Outer selector mechanism

To isolate vibrations from the drive line region, the gearbox is equipped with a cable-operated transmission.

Two selector cables connect the gear lever (on board the vehicle) and gearbox.

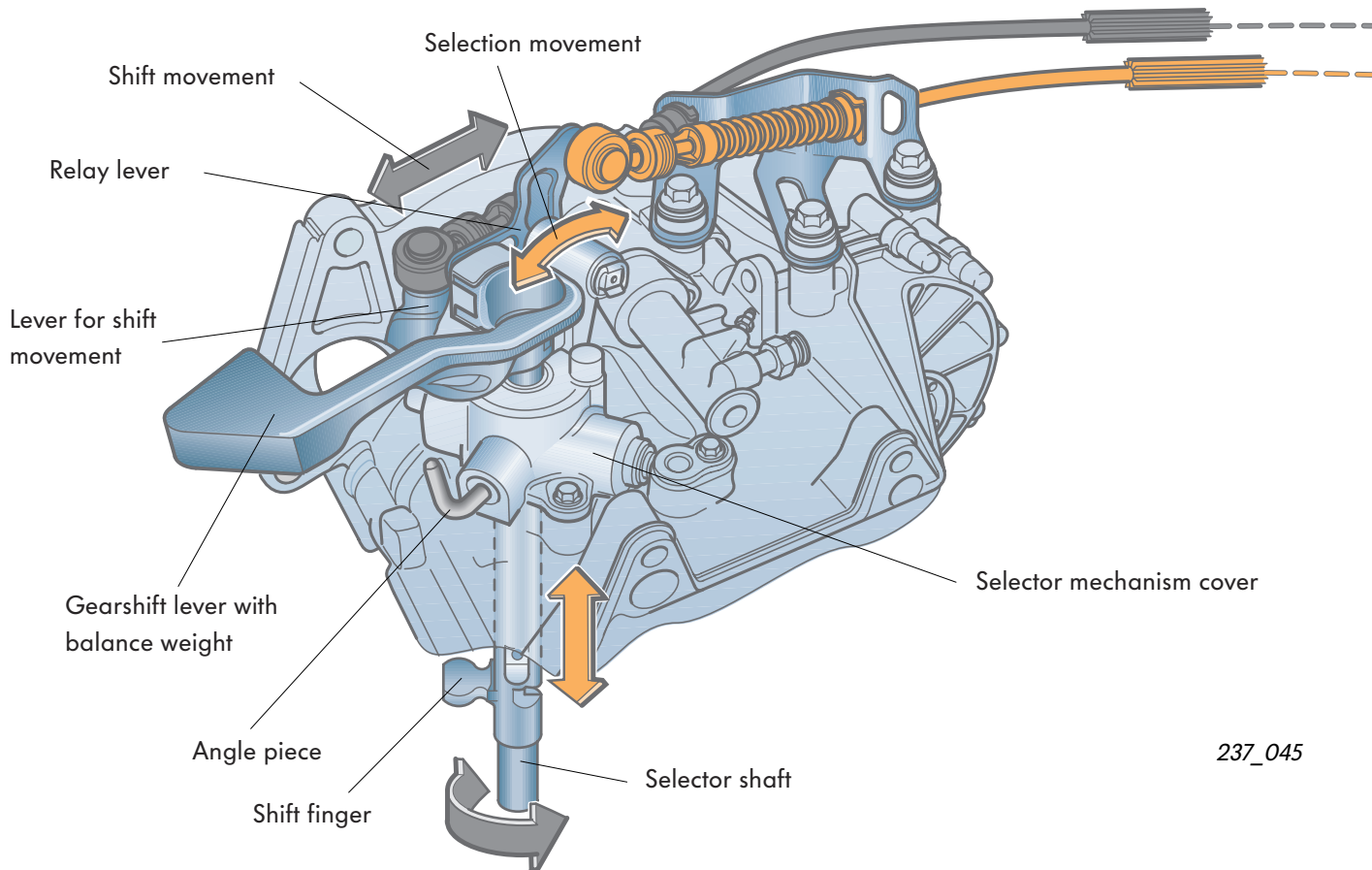

The two selector cables transmit the selection and shift movements of the gear lever to the selector shaft.

The mechanism (relay lever and lever for shift movement) translates the movements of the 2 selector cables to forward, reverse and rotary movements of the selector shaft.

An angle piece is attached to the selector mechanism cover. It locates the selector shaft in a pre-defined position so that servicing work can be carried out.

As a result, the cable pull transmission is much easier to adjust (Page 22).

A 4-gate selector mechanism, with reverse gear at the front left, was selected for the new manual gearbox.

The position of the other gears is the same as on the standard gearshift mechanism.

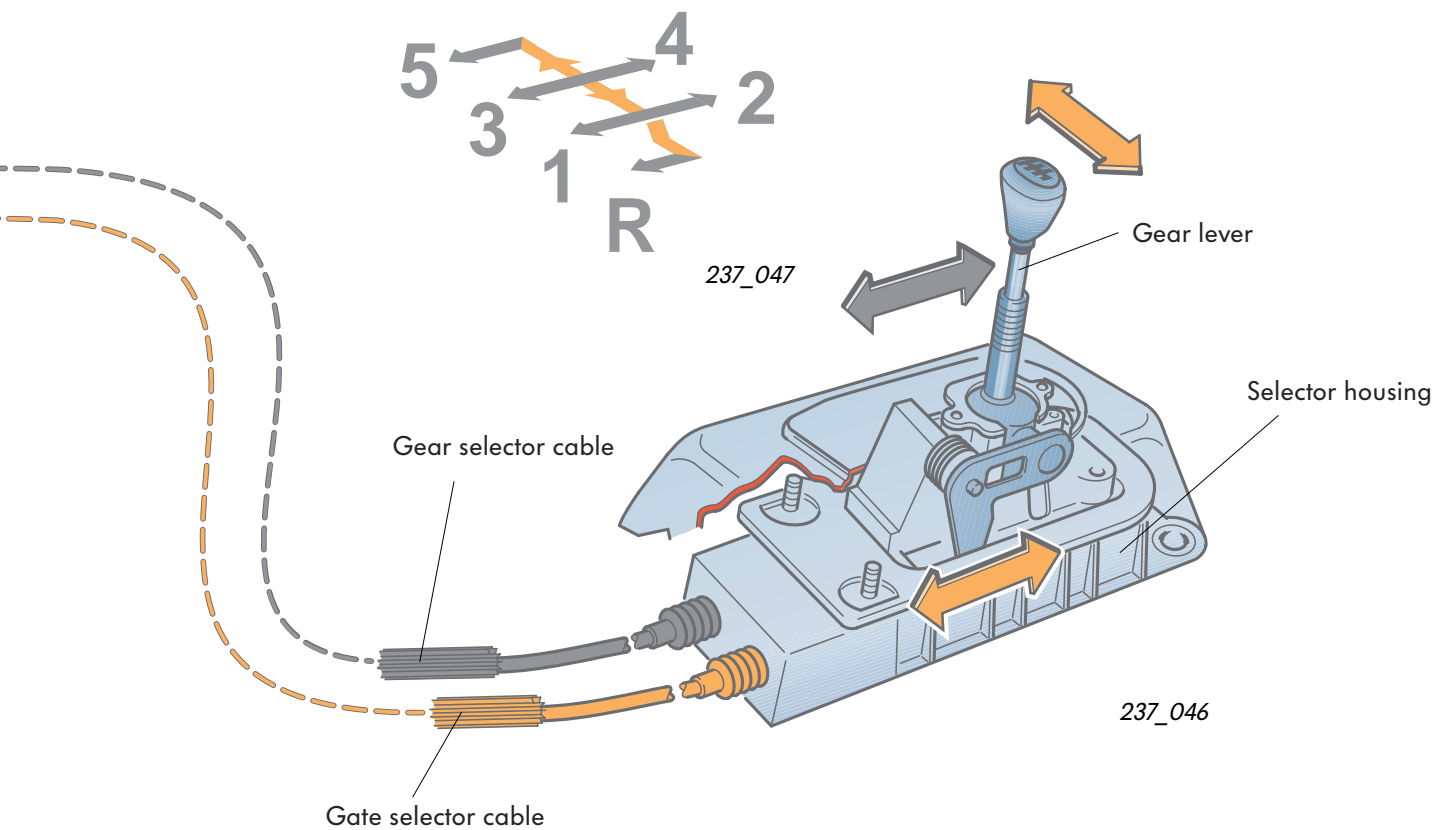

A conventional push lock (page 21) is used as a safeguard against unintentional engagement of reverse gear.

Selector mechanism

Inner gear change mechanism

The shift movements are transferred to the gearbox from above.

The selector shaft is located in the selector mechanism cover.

The selector shaft moves axially during selection movements and rotates during shift movements.

Two spring-loaded balls lock the selector shaft in position.

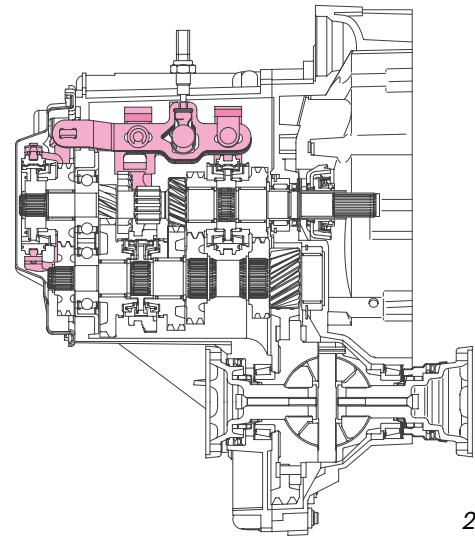

237_044

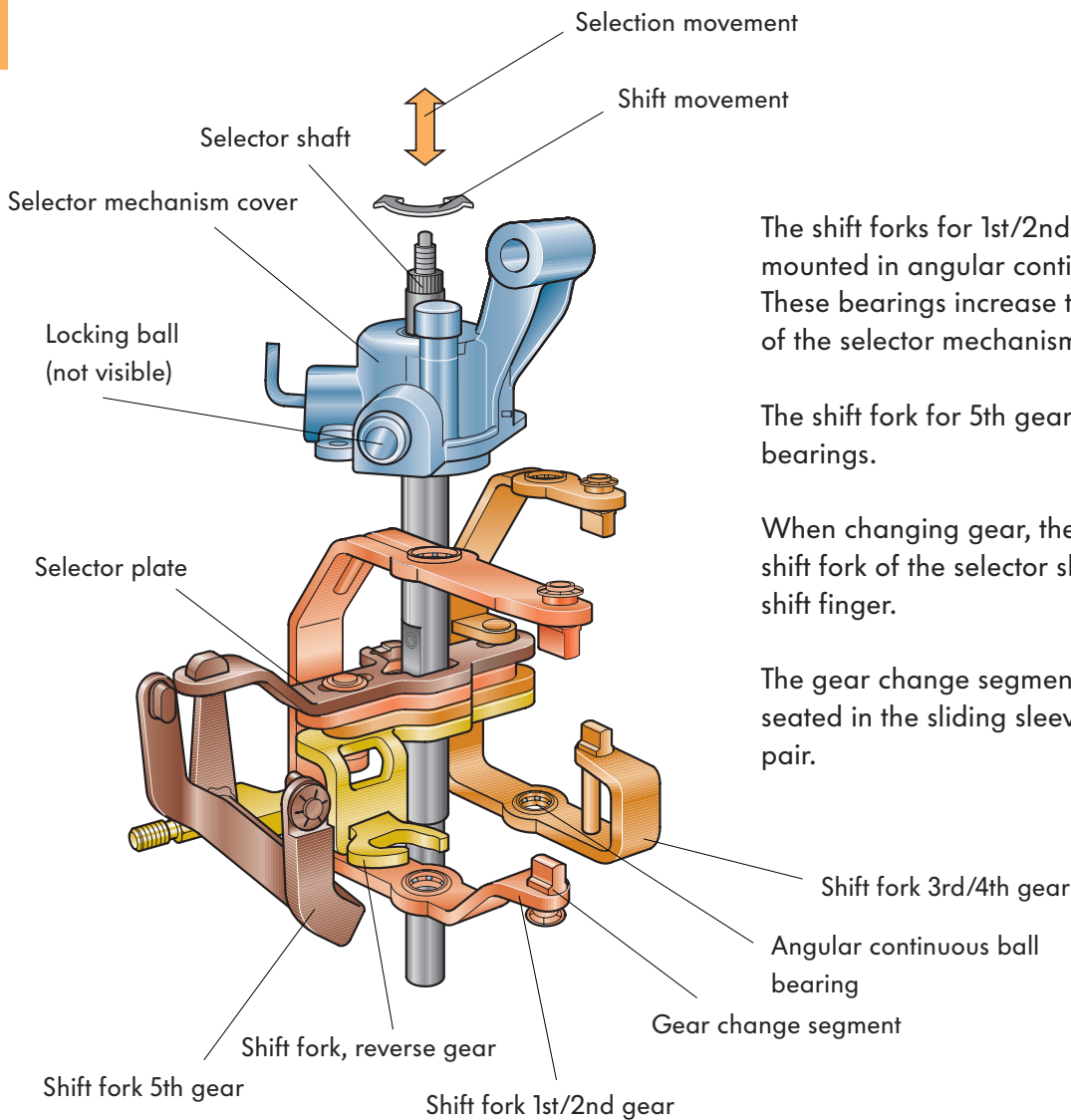

The shift forks for 1st/2nd and 3rd/4th gear are mounted in angular continuous ball bearings. These bearings increase the ease of movement of the selector mechanism.

The shift fork for 5th gear has low-friction bearings.

When changing gear, the selector plate and the shift fork of the selector shaft are moved by the shift finger.

The gear change segments of the shift forks are seated in the sliding sleeve of the relevant gear pair.

237_058

The selection movement

The selection movement (right-left) initiated at the gear lever is translated to backward and forward movement of the gate selector cable via the selector lever.

The selector lever is mounted in pivot bearings on the bearing shaft.

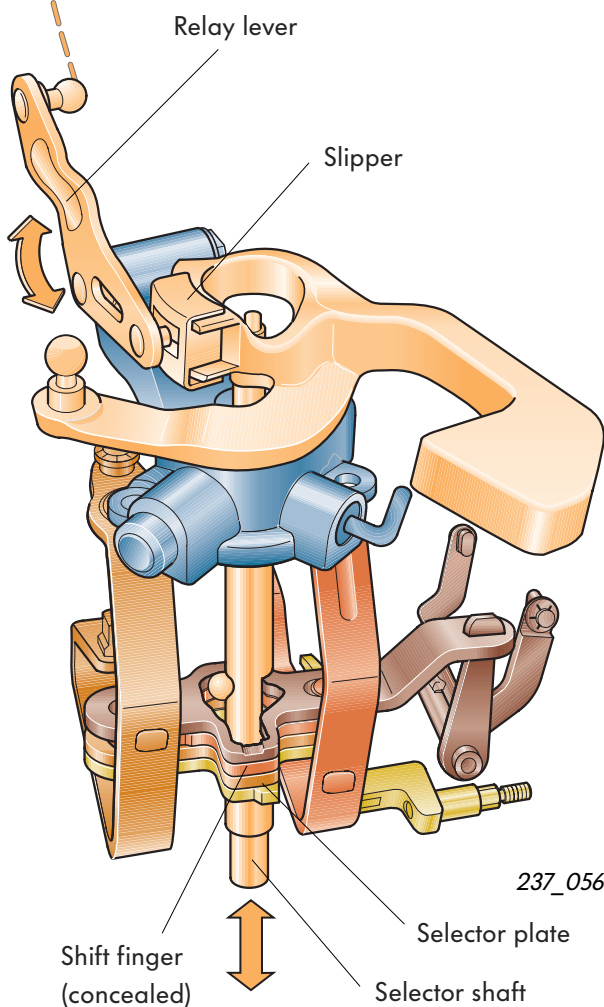
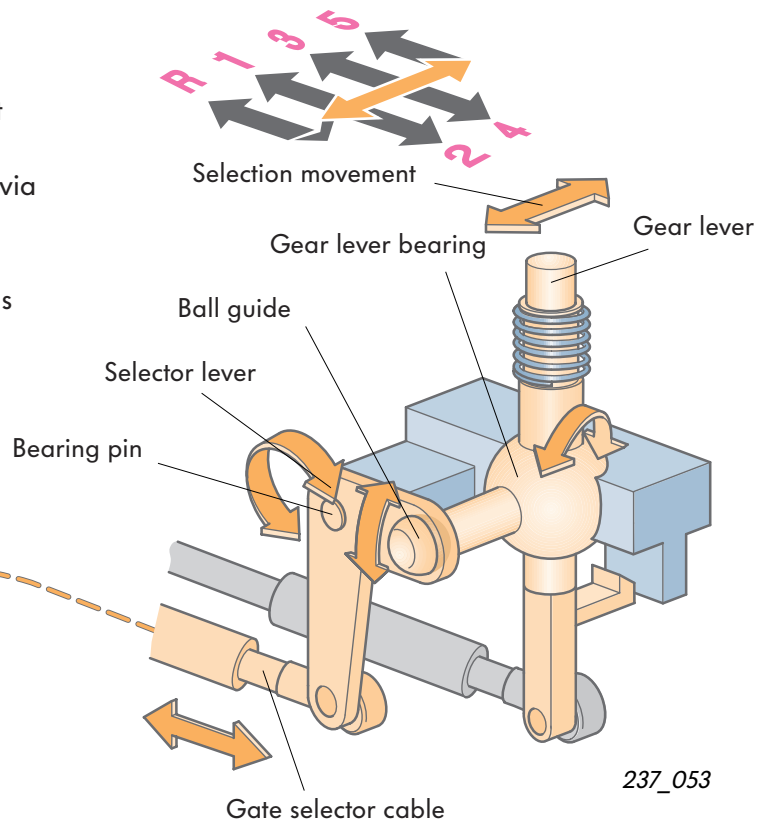

The backward and forward movements of the selector cable are translated to an up/down movement of the selector shaft by the outer mechanism on the gearbox.

For this purpose, the gate selector cable is fixed to the relay lever. The relay lever is mounted in pivot bearings and connected non-rigidly to the selector shaft by means of a slipper.

In the gearbox, this up/down movement locates the shift finger on the selector shaft in the relevant selector plate which the selected gear is to be engaged in (1st/2nd gear; 3rd/4th gear; 5th gear or reverse gear).



Selector mechanism

The gearshift movement

The direct gear shift movement is transferred via the selector lever guide to the gear selector cable.

If the gear lever is moved forwards or backwards in the direction of the individual gears, the gear selector cable is pulled or pushed in the opposite direction to the selector lever movement.

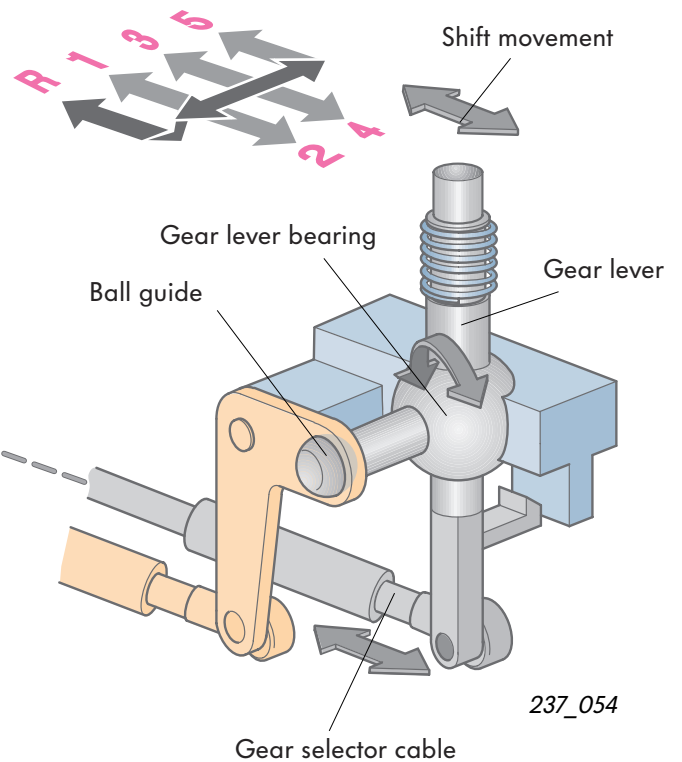

The forward or reverse movement of the gear selector cable during the gearshift causes the selector shaft to rotate.

The movable slipper keeps the gate selector cable relay lever unchanged in the position selected.

In the gearbox, the shift finger on the selector shaft moves the selector plate during this rotary movement. In turn, the selector shaft drives the shift fork and shifts the gear change sleeve.

The gear is now engaged.

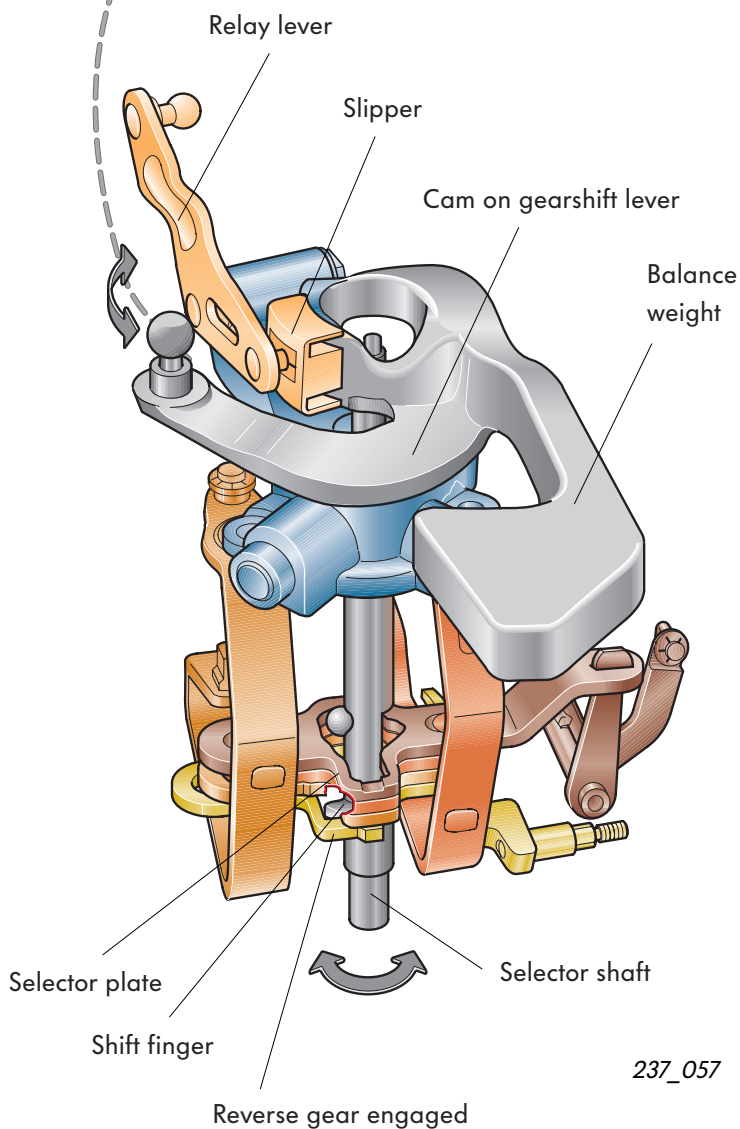

237_057

The reverse gear lock

A push lock serves as a safeguard against unintentional engagement of reverse gear.

The push lock is integrated in the selector housing.

The driver has to overcome the push lock first before reverse gear can be selected and engaged.

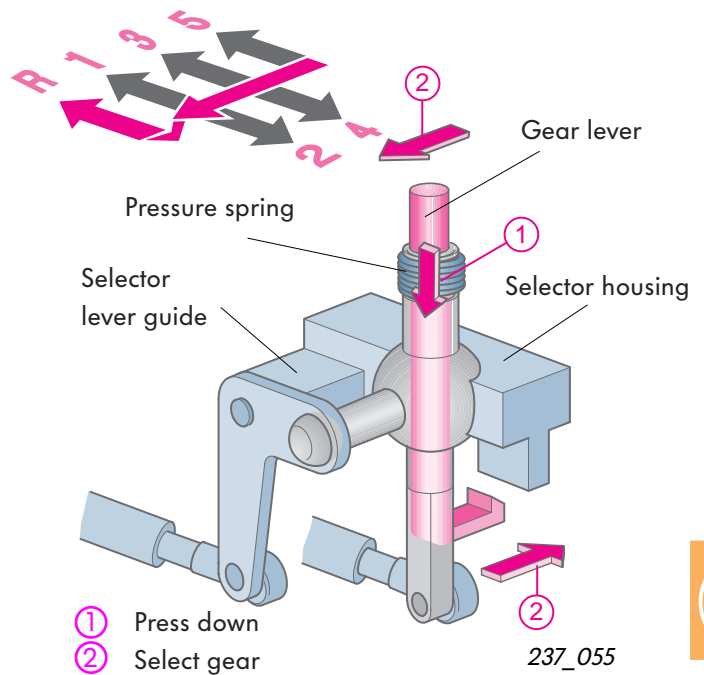
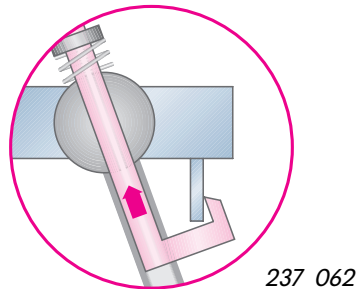
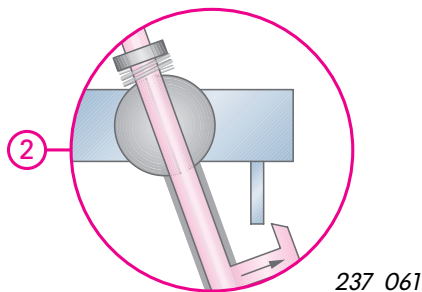
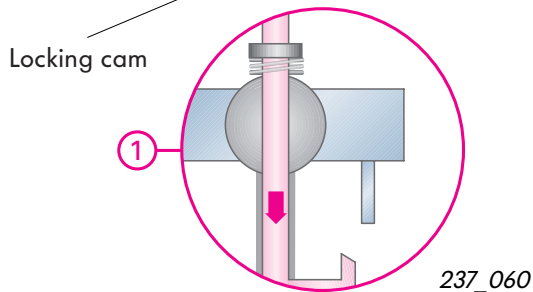
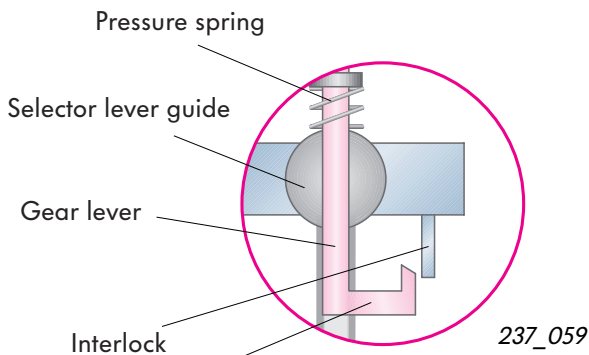

During a normal selection stroke of the forward gears, the locking cam of the gear lever comes up against the lock (an integral part of the selector housing).

When the gear lever is pressed down against the pressure spring, it glides downwards through the spherical selector lever guide; the locking cam is now located below the interlock.

During the reverse gear selection movement that follows, the interlock is bypassed allowing the reverse gear to be selected.

The pressure spring again pushes up the gear lever in the engaged position and holds it in the reverse position.



Adjusting the cable-operated gearbox

Adjustment of the cable-operated gearbox has been simplified by an angle piece on the selector mechanism cover and a locating pin for the gear lever.

The adjustment always begins when the gearbox is in the neutral position:

- **To detach the selector cables, follow this procedure:**

Draw the locking mechanism at the gear selector cable and at the gate selector cable forwards as far as the stop. ① Afterwards, engage locking mechanism by turning anticlockwise. ② The selector cables can now be adjusted for length.

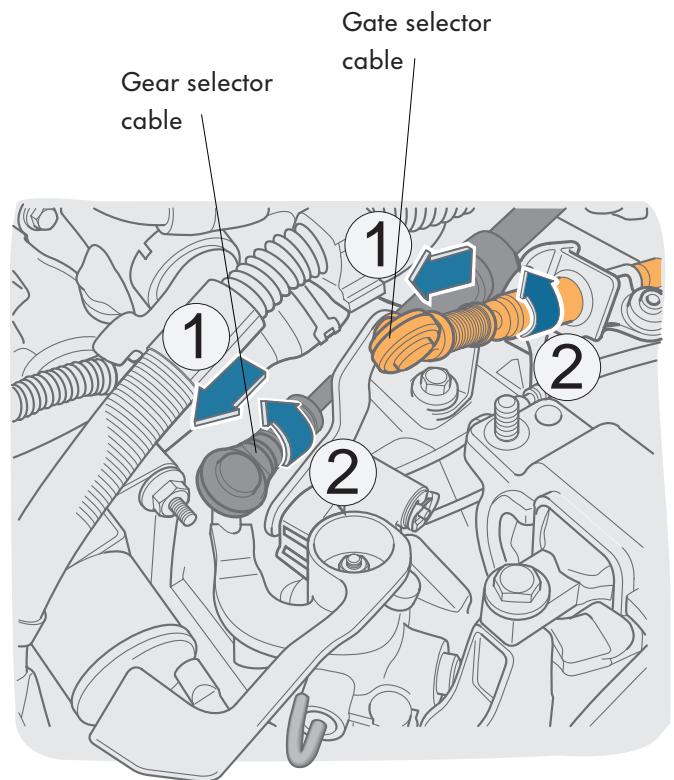

237_048

- **To arrest the selector shaft, follow this procedure:**

An angle piece which locates the selector shaft is fixed to the selector mechanism cover. To locate the selector shaft, press down the selector shaft by hand in the gate for 1st/2nd gear. When you press down the selector shaft, ① press the angle piece towards the selector shaft ② and then rotate in direction of arrow. ③ It engages and locates the selector shaft in this position.

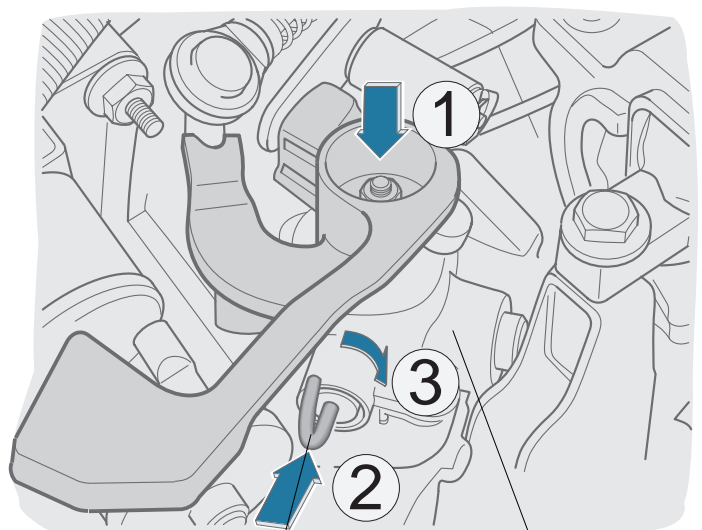

237_049

Angle piece

Selector mechanism cover

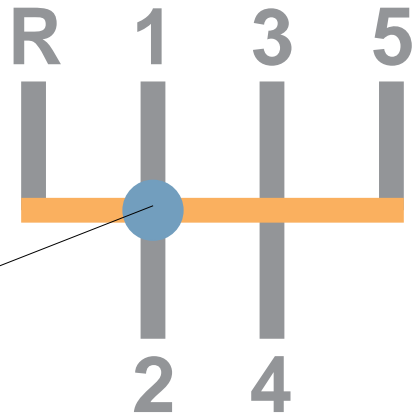

Position of gear lever during the setting operation

237_052

– **To arrest the gear lever, follow this procedure:**

With the engine running at idling speed, locate the gear lever in the gate of the 1st/2nd gear. The gear lever has a locating hole. Insert the locating pin T10027 through this bore and into the hole below it in the selector housing.

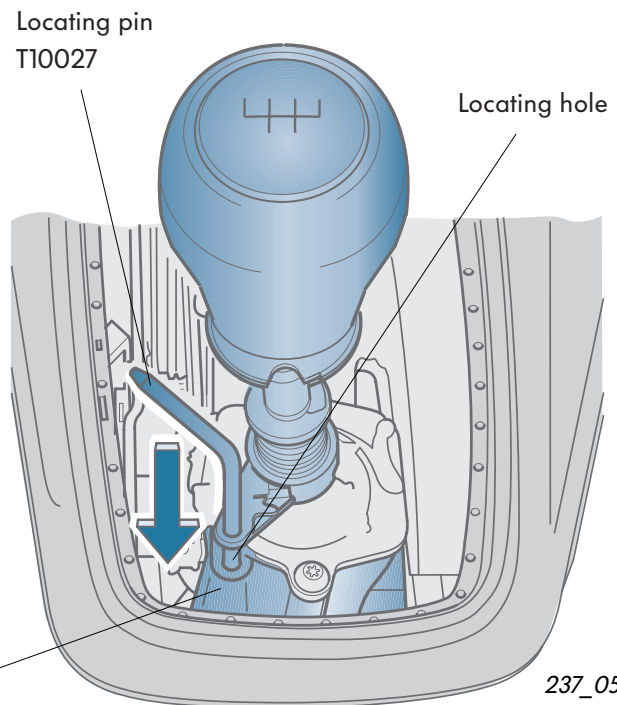

Selector housing

237_050

– **To fix the selector cables in position, follow this procedure:**

The locking mechanism on the gate selector cable and on the gear selector cable can now be turned clockwise. The spring presses the locking mechanism into the set position and secures it. Afterwards, detach the angle piece again and pull out the locating pin. The gear lever should now be in the gate of the 3rd/4th gear, with the engine running at idling speed.

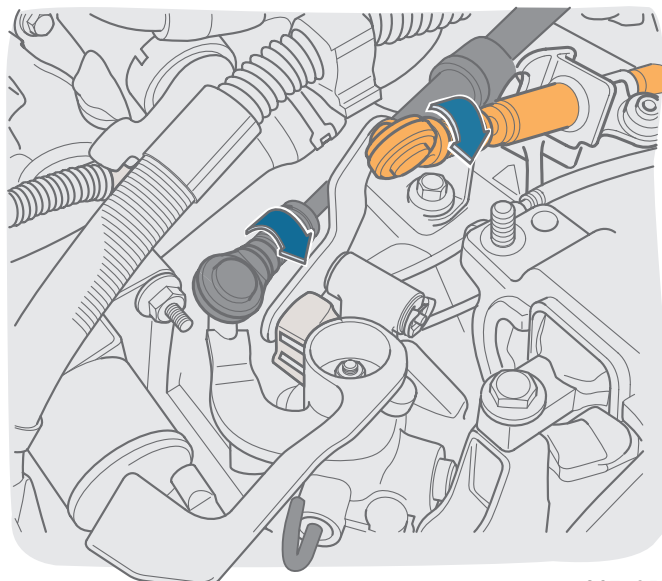

237_051



Sensors

Road speed display

An impulse sender wheel milled in the differential housing generates the signals that speedometer sender G22 requires to determine the actual road speed of the vehicle.

Speedometer sender G22 is inserted in a drill hole in the gearbox housing from the outside.

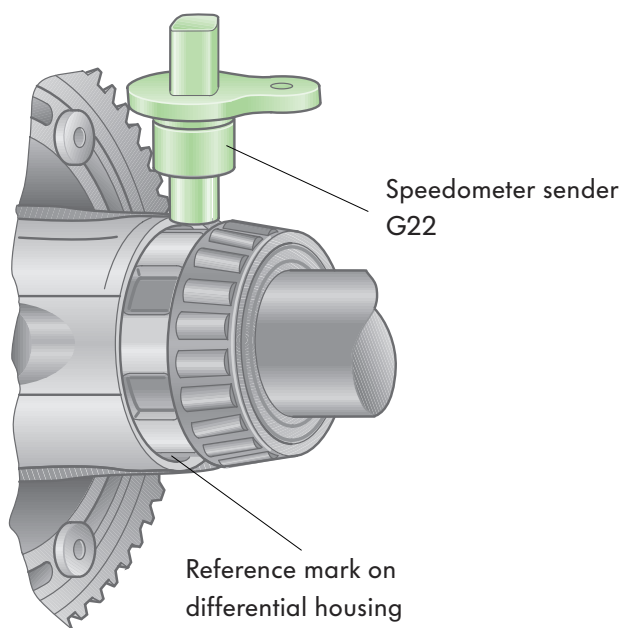

237_013

The sender operates according to the Hall sender principle. The electrical impulses generated by the sender are transmitted to the control unit in the dash panel insert. Here, the signals are conditioned for the actual road speed and mileage display.

Advantage:
Ultra-high display accuracy, smooth running, temperature resistant.

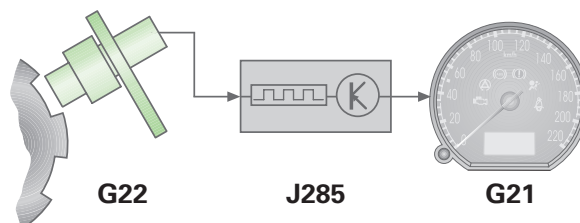

237_015

Electrical circuit

- D +15 Ignition switch, terminal 15
- G21 Speedometer
- G22 Speedometer sender
- J285 Control unit in dash panel insert

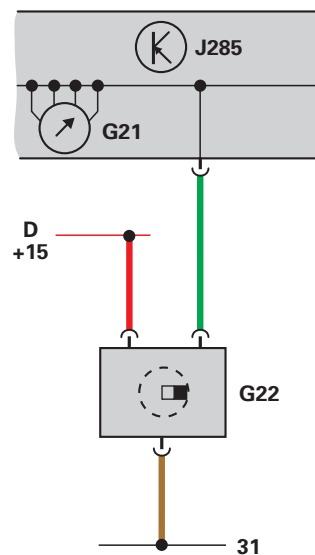

237_014

Reversing light switch F4

The reversing light switch is screwed into in the gearbox housing at the side.

When reverse is engaged, the switch is actuated by a rise on the reverse gear selector plate.

The electrical circuit for the reversing lights is closed.

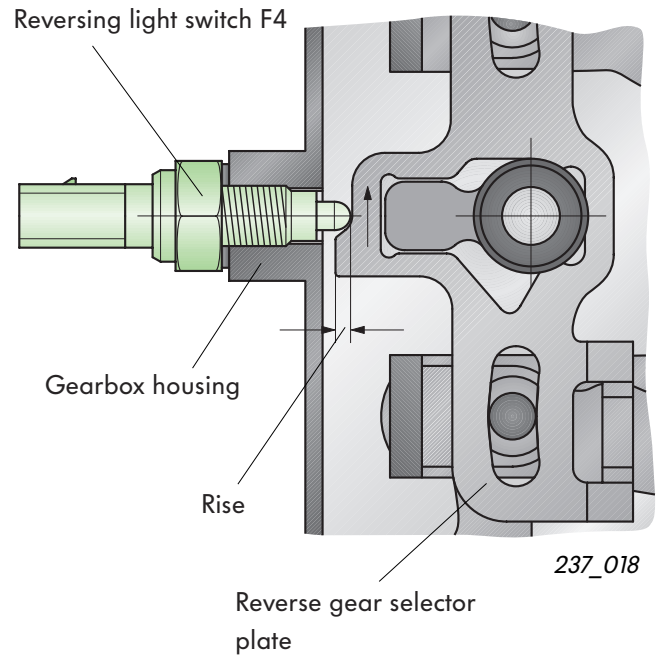

Electrical circuit

- D +15 Ignition switch, terminal 15
- F4 Reversing light switch
- M16 Reversing light bulb, left
- M17 Reversing light bulb, right

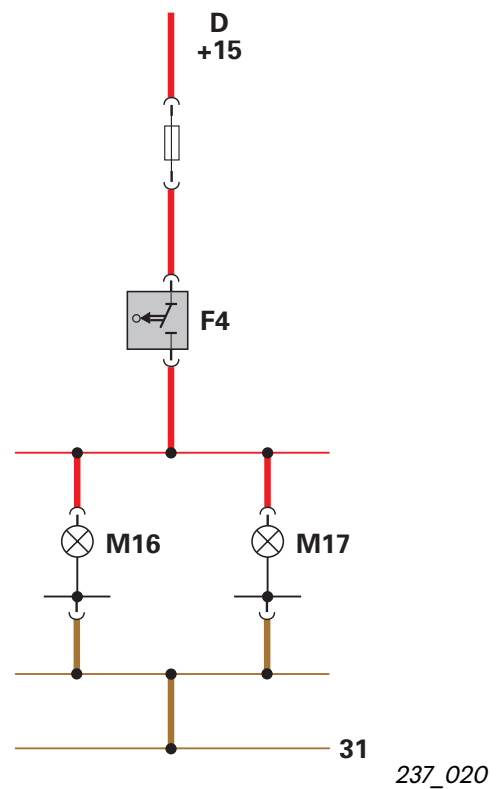

6-speed version

Gearbox design

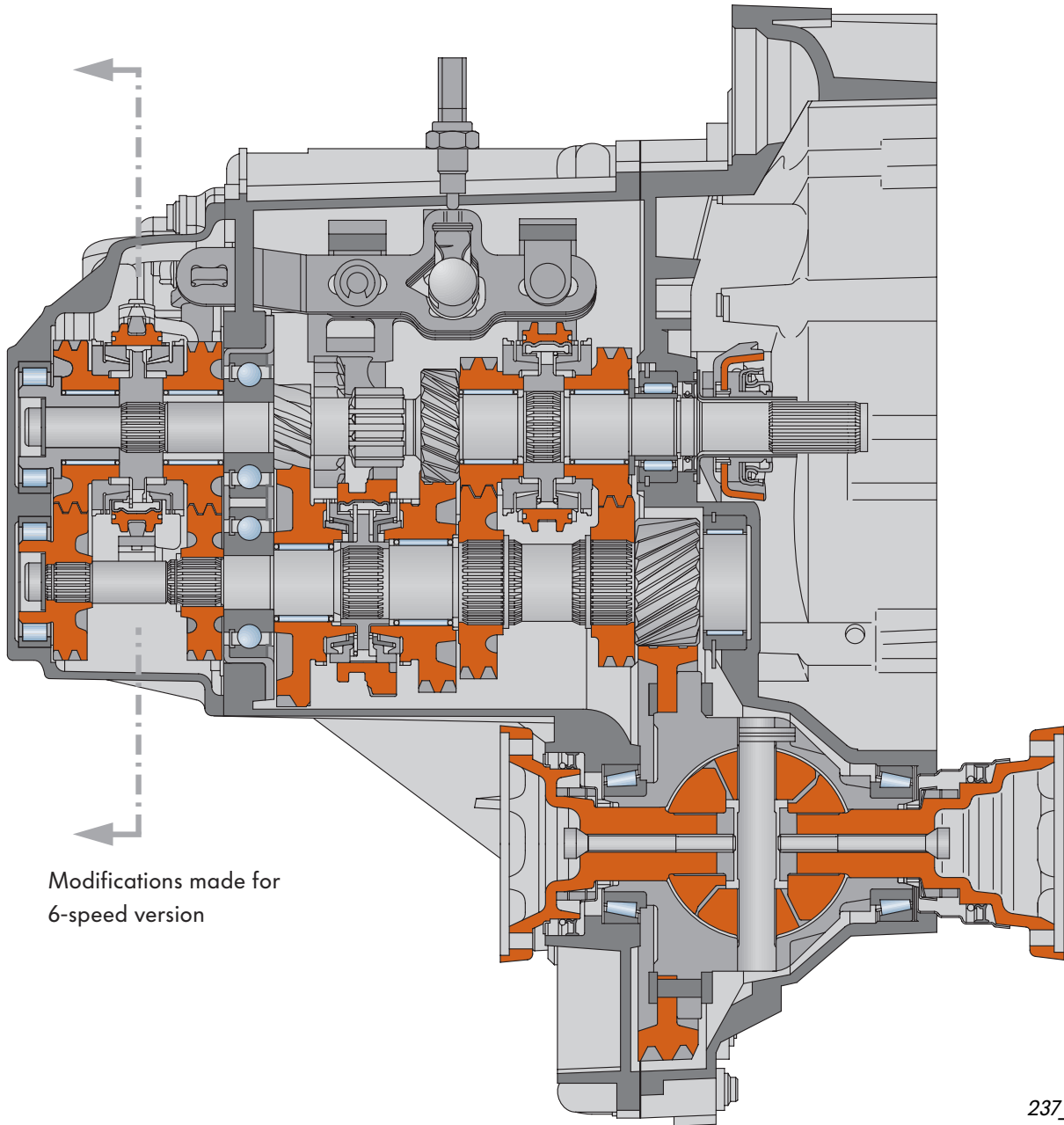

Modifications made for
6-speed version

237_001

In principle, the 6-speed gearbox has the same architecture as the 5-speed gearbox.

The gearbox housing cover had to be extended to accommodate the 6th gear, which also involved extending the input and output shafts.

The synchromesh body for the 5th gear was designed so that it can also be used to engage 6th gear.

Modifications to the 5-speed version

The components for the 6th gear are arranged in the gearbox housing cover.

The gearbox housing cover

Also covers the input and output shaft bearings.

Compared to the 5-speed version manufactured from sheet steel, a magnesium casting was used.

The input and output shafts

Were extended to accommodate the gear wheels and change gears for the 6th gear.

The change gear for the 6th gear runs in needle bearings on a sleeve of the input shaft. The sleeve is also used as a support bearing by the input shaft in the gearbox housing cover.

The gear wheel for the 6th gear is located on the output shaft by means of longitudinal tothing and is mounted, with a collar, in the roller bearing of the gearbox housing cover.

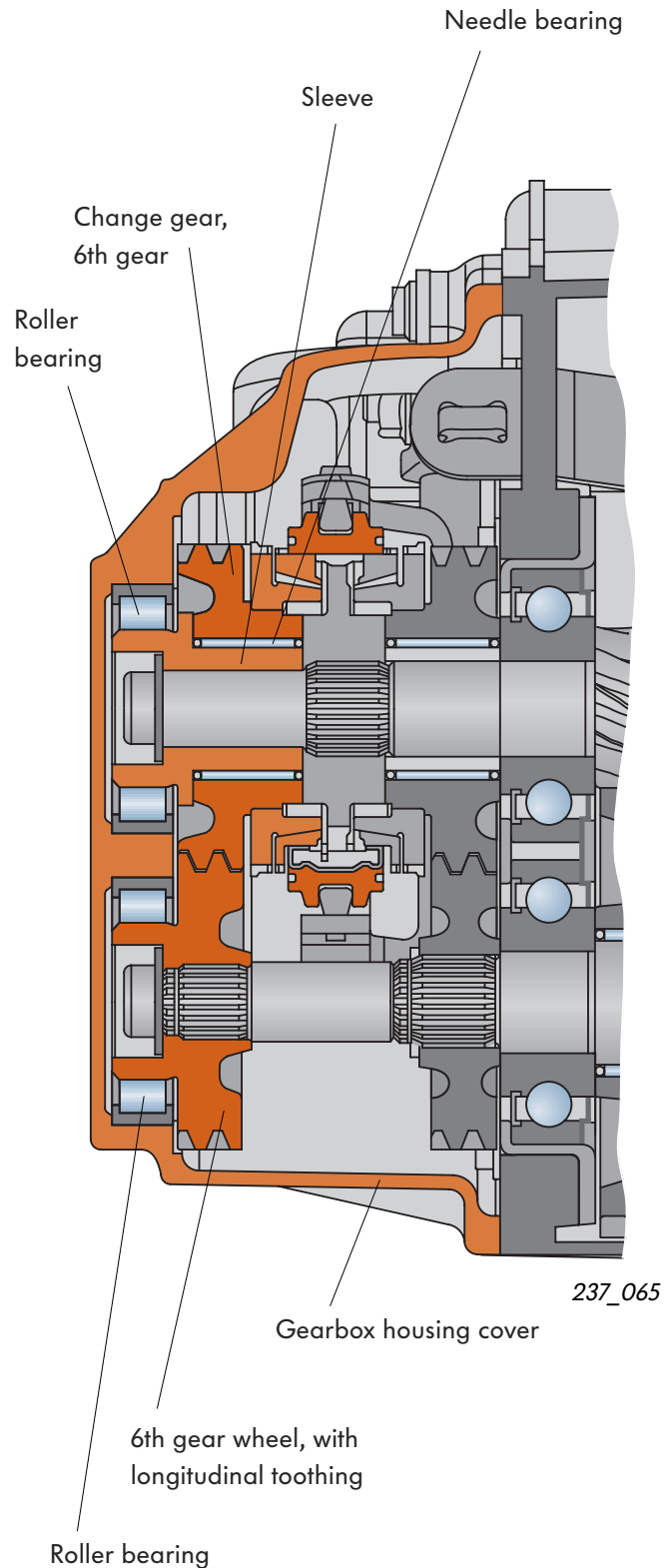

6-speed version

Force path

Engine torque is transferred to the gearbox via the input shaft.

In accordance with the gear selected, engine torque is transferred via the synchromesh body for 5th/6th gear to the output shaft and from here to the differential.

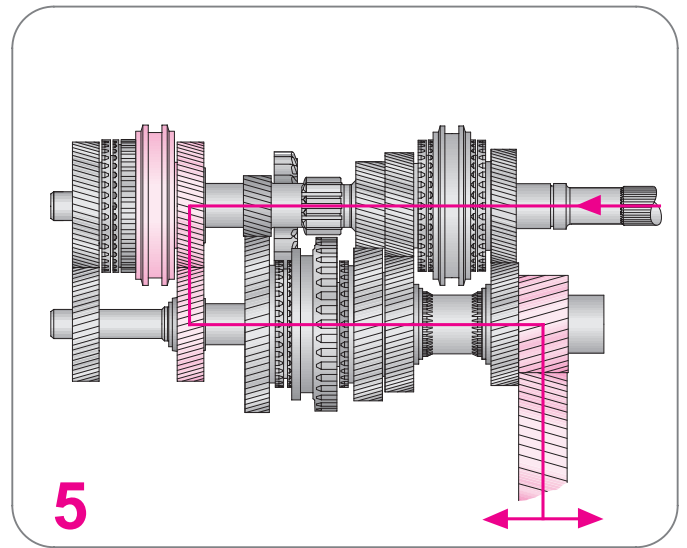

237_025

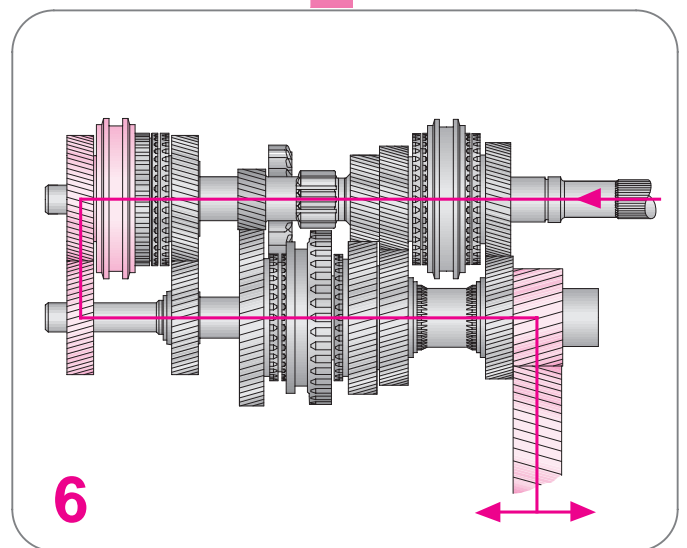
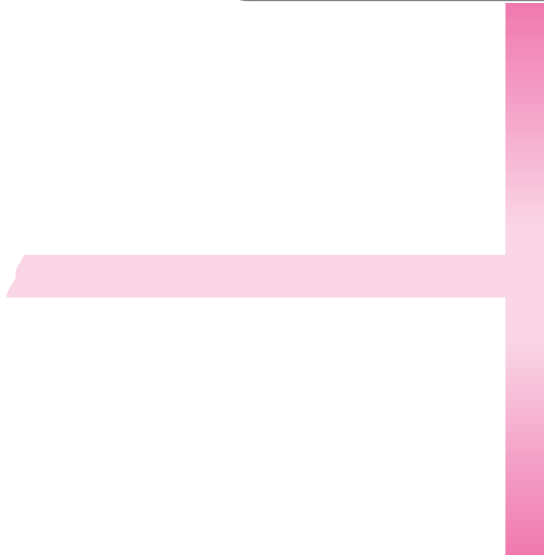

237_026

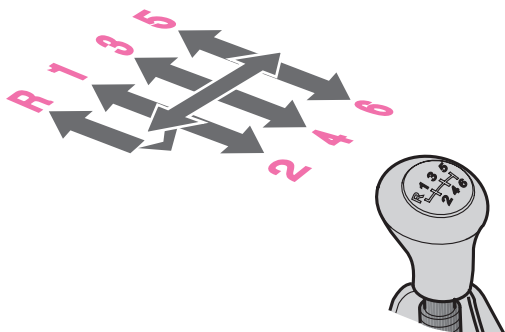

237_024

Test your knowledge

What answers are correct?

Sometime only one answer will be correct.

However, more than one – or all of the answers may also be correct.

Please fill in the gaps.

1. In the O2T manual gearbox, the gear and final drive ratios can be varied to a considerable degree. The advantages are:
 - A. Maximum ratio spread.
 - B. An optimum compromise between sporty and economical driving modes is possible for all vehicle applications.
 - C. It is possible to use the gearbox for different engine capacities and platforms throughout the Group.

2. The gearbox housing is manufactured from magnesium. The advantages are:
 - A. Drastic weight savings.
 - B. Enhanced vibration and noise comfort.
 - C. Considerable savings on cost of materials.

3. A characteristic of the gearbox is its modular design. Name at least three gearbox modules/assemblies
.....
.....
.....

4. The gearbox is equipped with the standard cable-operated transmission. The advantages are:
 - A. Low friction losses during operation.
 - B. The lateral forces and bending moments acting on the elements of the inner and outer selector mechanisms are kept to a minimum.
 - C. Mechanical vibration is isolated from the drive line region.



5. The angle piece on the selector mechanism cover is used to
 - A. Fix the selector shaft in a pre-defined position.
 - B. Fix the gearshift lever in a pre-defined position.
 - C. Simplify adjustment of the standard cable-operated transmission.

6. The range of special tools includes locating pin T10027. It is used to
 - A. Fix the gear lever in the gate for 1st/2nd gear.
 - B. Lock the selector shaft.
 - C. Adjust the gear lever in relation to the selector housing.

7. Road speed is reduced via
 - A. Mechanical intermediate steps ... speedometer drive wheel and speedometer drive shaft.
 - B. Sensors on the gearbox and wireless transmission to the control unit in the dash panel insert.
 - C. Direct engine speed reduction at the differential housing by a Hall sender and subsequent transfer to the control unit in the dash panel insert.

8. The bearing support is a new feature of the transmission shaft bearing.
 - A. As a result, the bearings can be exchanged quickly, easily and individually.
 - B. After repair work, the bearing support must be replaced completely.
 - C. The complete shaft and gear packet of the input and output shafts and the bearing support is pre-assembled as a module.



1. A, B; 2. A; 3. Clutch release lever, selector shaft with selector mechanism cover, inner gear change mechanism, bearing support for input and output shafts; 4. C; 5. A, C; 6. A, C; 7. C; 8. B, C.

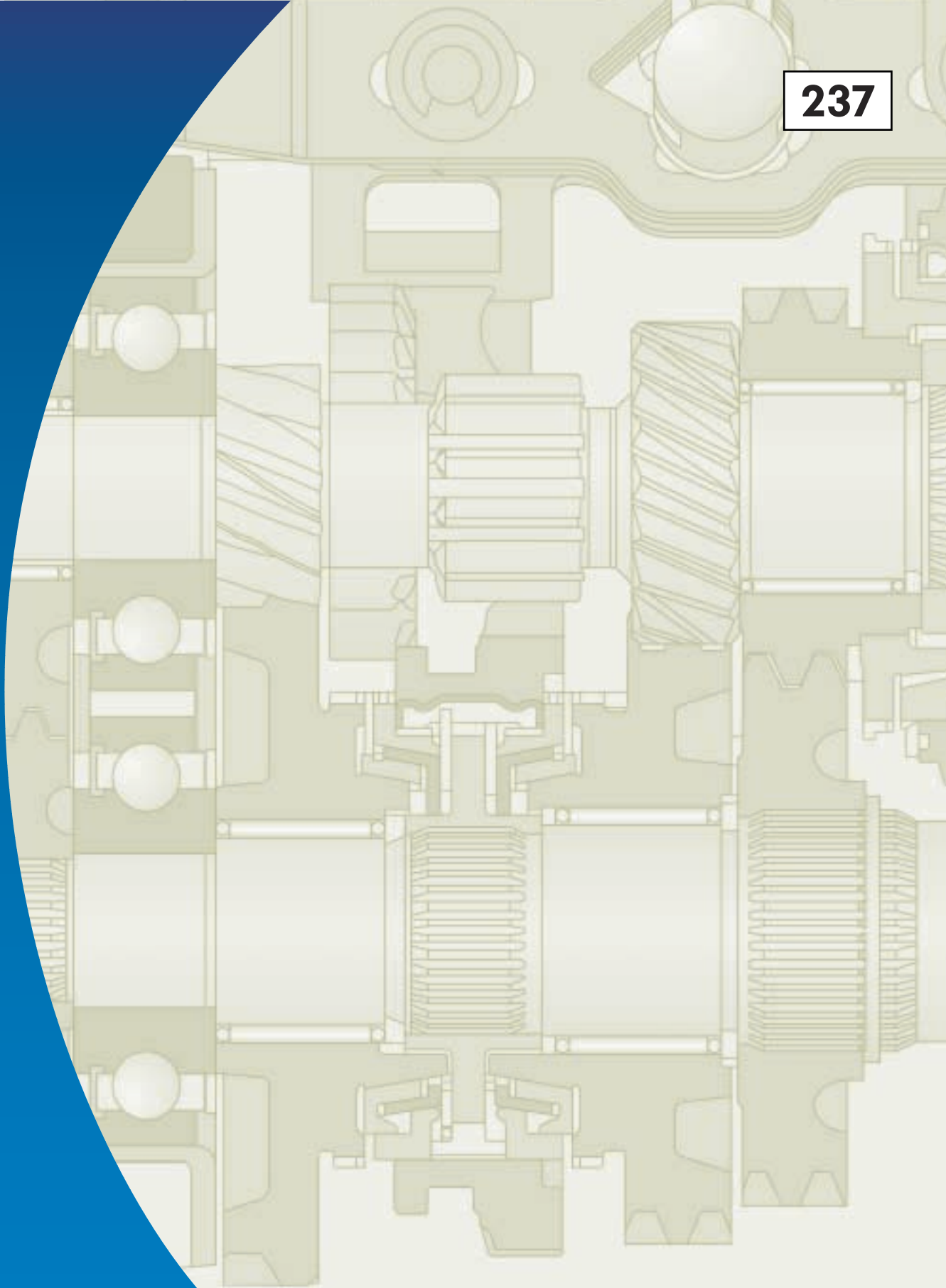

For internal use only © VOLKSWAGEN AG, Wolfsburg

All rights reserved. Technical specifications subject to change without notice.

940.2810.56.20 Technical status: 01/00

 This paper is produced from
non-chlorine-bleached pulp.