

01-253



Air conditioning, electrical testing

Wire and component test using VAG1598 A test box

Special tools and equipment

- ◆ VAG 1598 A test box and VAG 1598/11 adapter cable and VAG 1598/12
- ◆ VAG1526
Multimeter

or

- ◆ VAS 5051 Vehicle diagnostic, Test Instruments and Information system, with measuring leads VAS 5051/7, DSO measuring cable VAS 5051/8, Current pick-up clamp 50 A VAS 5051/9 (for vehicles from model year 2002)
- ◆ VAG 1527 B Voltage Tester

Vehicle

System

Repair Group

Previous Topic

Next Topic

Technical
Bulletins

Wiring Diagrams

Warnings &
Cautions

Print

Search

Advanced
Search

 eBahn®
Version: 2.5r01sp0003

◆ VAG1594A connector test
kit

◆ Temperature sensor with suitable
tester

01-254



Note:

The adapters from VAG 1598 A test box must not be connected to the A/C Control Head -E87- during the self diagnostic.

Connect VAG 1598 A test box to wiring harness of A/C Control Head -E87-

- Switch ignition off.
- Remove A/C Control Head -E87- ⇒ [Page 87-96](#) .

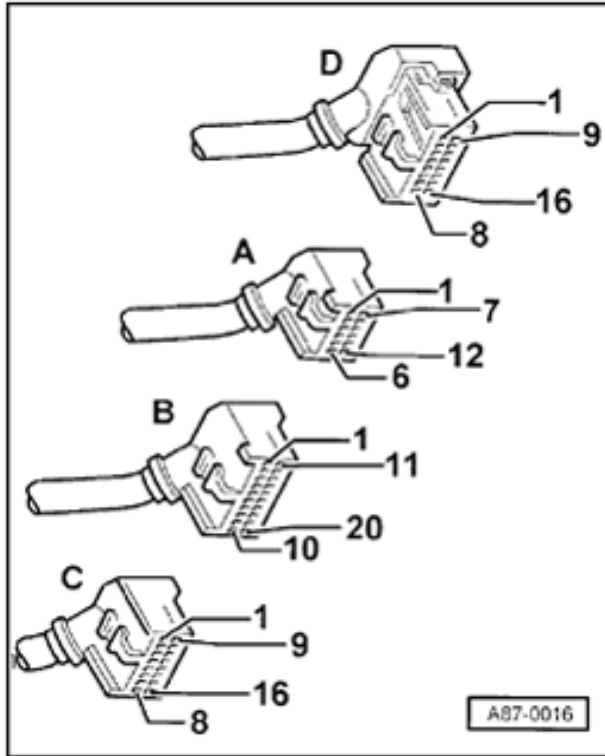

- Connect adapter cable VAG 1598/11 and VAG 1598/12 to disconnected harness connectors of A/C Control Head -E87-.

Notes:

- ◆ Do not connect A/C Control Head -E87- (except on requested test steps).
- ◆ To carry out the measurement, connect the VAG 1598 A to relevant adapter lead.
- ◆ The socket assignment on VAG 1598/12 adapter corresponds exactly to the terminal assignment on the A/C Control Head -E87-.
- ◆ The socket assignment on VAG 1598/11 adapter corresponds exactly to the terminal assignment on the A/C Control Head -E87-.

01-255



Checking

Notes:

- ◆ *The electrical testing on vehicles up to model year 2001 is described with VAG 1526 multi-meter. The electrical testing on these vehicles can also be carried out using the VAS 5051 Vehicle Diagnostic, Testing and Information System.*
- ◆ *The electrical testing on vehicles from model year 2002 is described with the VAS 5051 Vehicle Diagnostic, Testing and Information System. The electrical testing can also be carried out using VAG 1526 multi-meter, except for several test steps.*
- ◆ *With model year change 2001 to 2002 the A/C system control will be changed over. For Audi allroad, the change-over of the A/C system is not performed with the model year change 2001 to 2002, instead it is a running change (implementation open, for vehicles with 4.2 Liter engine with start of production).*

⇒ *Parts Catalog*

01-256



Test requirement:

- All fuses OK:

⇒ *Electrical Wiring Diagrams, Troubleshooting & Component Locations*

- Adapter cable VAG 1598/11 and VAG 1598/12 connected to disconnected harness connectors of A/C Control Head -E87-.

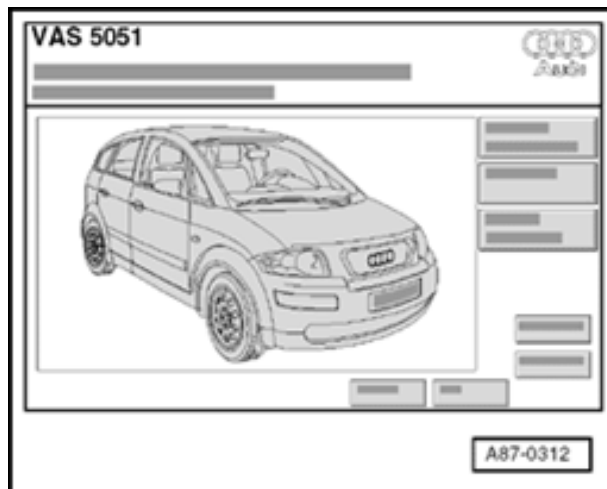

- Select operating mode "Test instrument" on VAS 5051 Vehicle Diagnostic, Testing and Information System

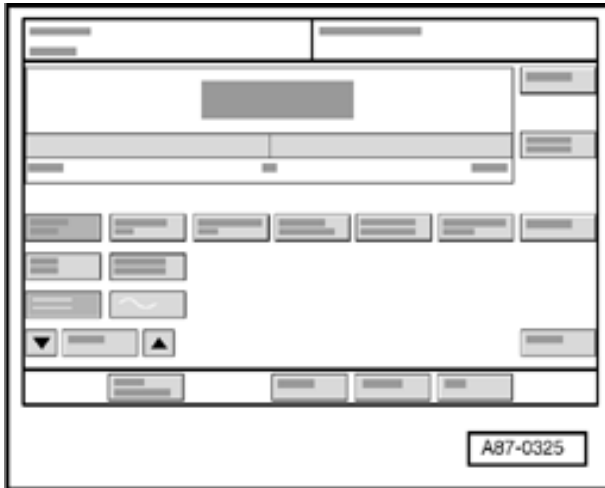

- Select during variable test steps the required test instrument types, by clicking the relevant button on VAS 5051 display.
- Adjust on VAG 1526 multi-meter the type of test instrument at variable test steps.

Electrical testing:

- for vehicles up to model year 2001 ⇒ [Page 01-259](#) .
- for vehicles from model year 2002 ⇒ [Page 01-288](#) .

01-257



Socket assignment for VAG 1598 test box with adapter lead VAG 1598/11

Notes:

- ◆ *The terminal assignment for connectors A and B on the VAG 1598/11 adapter does not match the socket assignment on the test box.*
- ◆ *The terminal assignment for connector -C- on the VAG 1598/11 adapter matches exactly the socket assignment on the test box.*
- ◆ *The terminal assignment for connector -D- on the VAG 1598/12 adapter matches exactly the socket assignment on the test box.*
- ◆ *Because the connectors for the A/C Control Head -E87- are distributed over two adapter leads ((VAG 1598/11 and 12) there is no Ground (GND) connection for testing purposes when only adapter lead VAG 1598/11 is connected. Therefore, for various steps of the electrical test it is necessary to use a suitable Ground connection point on the body of the car, or to use a second VAG 1598 test box. With the VAG 1598/12 adapter the Ground (GND) connection is through terminal 14).*

Connector A	VAG 1598 Socket	Connector B	VAG 1598 Socket	Connector C	VAG 1598 Socket
1	41	1	21	1	1
2	42	2	22	2	2
3	43	3	23	3	3
4	44	4	24	4	4

01-258



Connector A	VAG 1598 Socket	Connector B	VAG 1598 Socket	Connector C	VAG 1598 Socket
5	45	5	25	5	5
6	46	6	26	6	6
7	47	7	27	7	7
8	48	8	28	8	8
9	49	9	29	9	9
10	50	10	30	10	10
11	51	11	31	11	11
12	52	12	32	12	12
		13	33	13	13

		14	34	14	14
		15	35	15	15
		16	36	16	16
		17	37		
		18	38		
		19	39		
		20	40		



Electrical testing (vehicles up to model year 2001)

Notes:

- ◆ *Connect VAG 1598A test box to vehicle wiring harness ⇒ [Page 01-253](#)*
- ◆ *Observe notes at electrical testing ⇒ [Page 01-253](#) onward.*
- ◆ *The socked assignment on VAG 1598/11 adapter corresponds exactly to the terminal assignment on the A/C Control Head -E87-.*

Electrical tests (to be performed on A/C Control Head -E87-) overview

Test step	Component tested	page
1	<ul style="list-style-type: none">- Voltage supply, Ground (GND) connection and illumination for A/C control head -E87-.- Ignition Time Period Signal Off- Ground (GND) connection	⇒ Page 01-261
2	<ul style="list-style-type: none">- Temperature sensors (-G17-, -G89-, -G150-, -G151-, and -G192-)	⇒ Page 01-266
3	<ul style="list-style-type: none">- Fresh air blower with control module (-V2-, -J126-)	⇒ Page 01-269



Test step	Component tested	page
4	- Air conditioner positioning motors with potentiometers (-V70-/-G112-, -V71-/-G113-, -V107-/-G135-, -V158-/-G220-, -V159-/-V221-)	⇒ Page 01-271
5	- A/C Pressure Switch - F129- - Signal "Engine temperature too high" - Output for "A/C compressor cut-in"	⇒ Page 01-275
6	- Voltage supply for A/C clutch - Coolant fan -V7- activation - Activation of A/C clutch - N25-	⇒ Page 01-280

7

Outputs/inputs only installed in conjunction with certain vehicle equipment combinations

⇒ [Page 01-284](#)

- Input for auxiliary heater (not applicable for USA)

- not for USA

- Input for solar sunroof

01-261



Test step 1 - Voltage supply, Ground (GND) connection and illumination for A/C control head -E87-

Switch VAG 1526 multimeter to test mode:

Voltage measurement (20 V =)

- VAG 1598/12 adapter cable connected

Test step	VAG 1598 socket	Test of	<ul style="list-style-type: none"> • Test requirements - Additional operations	Specified value	Corrective actions for deviation from specification
1.1	9 and 15	Terminal 15 and Ground (GND) connection on A/C Control Head - E87-	<ul style="list-style-type: none"> • Ignition switched on. 	- Approx. battery voltage	- Repair voltage supply or Ground (GND) connection according to wiring diagram.
1.2	9 and 14	Terminal 15 and Ground (GND) connection on A/C Control Head - E87-	<ul style="list-style-type: none"> • Ignition switched on. 	- Approx. battery voltage	- Repair Ground (GND) connection according to wiring diagram.

01-262

Switch VAG 1526 multimeter to test mode:
Voltage measurement (20 V =)

- VAG 1598/11 adapter cable
connected

Test step	VAG 1598 socket	Test of	<ul style="list-style-type: none"> • Test requirements - Additional operations	Specified value	Corrective actions for deviation from specification
1.3	7 and Ground (GND)	Terminal 58s on A/C Control Head -E87-	<ul style="list-style-type: none"> • Ignition switched on. • Running light switched on. 	- 0 to 12 volt	- Locate and repair short circuit or open circuit according to wiring diagram.
1.4	7 and Ground (GND)	Terminal 58s on A/C Control Head -E87-	<ul style="list-style-type: none"> • Ignition switched on. • Running light switched off. 	- about 0 V	- Eliminate short circuit to B+ according to wiring diagram.

Notes:

- ◆ *Ground is at, for example, connector -D-, socket 14 and 15.*

- ◆ *The voltage on terminal 58s depends on the adjustment of instrument panel light dimmer switch.*

01-263

Switch VAG 1526 multimeter to test mode:
Voltage measurement (20 V =)

- VAG 1598/11 adapter cable
connected

Test step	VAG 1598 socket	Test of	<ul style="list-style-type: none"> • Test requirements - Additional operations 	Specified value	Corrective actions for deviation from specification
1.5	45 and Ground (GND)	Terminal 58d on A/C Control Head -E87-	<ul style="list-style-type: none"> • Ignition switched on. • Running light switched on. 	- 0 to 12 volt	- Locate and repair short circuit or open circuit according to wiring diagram.
1.6	45 and Ground (GND)	Terminal 58d on A/C Control Head -E87-	<ul style="list-style-type: none"> • Ignition switched on. • Running light switched off. 	- 0 to 12 volt	- Locate and repair short circuit or open circuit according to wiring diagram.

Notes:

- ◆ *Ground is at, for example, connector -D-, socket 14 and 15.*

- ◆ *The voltage at terminal 58d is generated as a square-wave signal by the instrument cluster. The brightness level of the display on the A/C Control Head -E87- depends on the period of activation, the tester displays the transmitted value.*

- ◆ *The activation period of terminal 58d depends on the adjustment of Instrument Panel Light Dimmer Switch and the determined brightness level from the photo sensor in the instrument cluster.*

01-264



Switch VAG 1526 multimeter to test mode:

Resistance measurement (200 Ω)

- VAG 1598/11 adapter cable connected

Test step	VAG 1598 socket	Test of	<ul style="list-style-type: none"> Test requirements - Additional operations	Specified value	Corrective actions for deviation from specification
1.7	49 and 52	Ground (GND) connection		- Less than 2 Ω	- Locate and repair open circuit or contact resistance according to wiring diagram.

01-265

**VAG 1527 voltage tester**

- VAG 1598/11 adapter cable connected

Test step	VAG 1598 socket	Test of	<ul style="list-style-type: none"> • Test requirements <p>- Additional operations</p>	Specified value	Corrective actions for deviation from specification
1.8	41 and Ground (GND)	Ignition Time Period Signal Off	<ul style="list-style-type: none"> • Ignition switched on. 	- LED in voltage tester illuminates.	- Locate and repair short circuit or open circuit according to wiring diagram.
1.9	41 and Ground (GND)	Ignition Time Period Signal Off	<ul style="list-style-type: none"> • Ignition switched on. <p>- Start engine.</p>	<p>- LED in voltage tester illuminates.</p> <p>- LED in voltage tester briefly blinks (time signal) when starting engine and continuous to illuminates.</p>	<p>- Locate and repair short circuit or open circuit according to wiring diagram.</p> <p>- Check instrument cluster.</p> <p>⇒ <i>Repair Manual, Electrical Equipment On Board Diagnostic (OBD), Repair Group 01.</i></p>

Note:

Ground is at, for example, connector -D-, socket 14 and 15.

01-266



Test step 2 (Temperature sensors)

Switch VAG 1526 multimeter to test mode:

Resistance measurement (20 K Ω)

- VAG 1598/11 adapter cable connected

Test step	VAG 1598 socket	Test of	<ul style="list-style-type: none"> • Test requirements - Additional operations	Specified value	Corrective actions for deviation from specification
2.1	29 and 49	Outside air temperature sensor -G17-	- Measure temperature at installation location of sensor.	- Dependent on temperature at installation location of sensor	- Locate and repair short, open circuit or contact resistance according to wiring diagram.
2.2	10 and 49	Left Vent Temperature Sensor -G150-	- Measure temperature at installation location of sensor.	⇒ Table ⇒ Page 01-268 .	- Replace temperature sensor.

2.3	31 and 49	Right Vent Temperature Sensor -G151-	- Measure temperature at installation location of sensor.		
-----	-----------	--	---	--	--

01-267



Switch VAG 1526 multimeter to test mode:

Resistance measurement (20 K Ω)

- VAG 1598/11 adapter cable connected

Test step	VAG 1598 socket	Test of	<ul style="list-style-type: none"> • Test requirements - Additional operations	Specified value	Corrective actions for deviation from specification
2.4	40 and 49	Fresh Air Intake Duct Temperature Sensor -G89-	- Measure temperature at installation location of sensor.	- Dependent on temperature at installation location of sensor	- Locate and repair short, open circuit or contact resistance according to wiring diagram.
2.5	30 and 49	Sensor for outlet temperature, floor outlet -G192-	- Measure temperature at installation location of sender.	⇒ Table ⇒ Page 01-268 .	- Replace temperature sensor.

01-268



Outside temperature dependent resistance values of temperature sensors in $K\Omega$ (Kilo-Ohm)

Temperature measured at installation location of sensor in $^{\circ}C$ (Degree Celsius)	Sensors	Sensors
	-G150- -G151- -G192-	-G17- -G89-
-20	(79)	9.95
-10	(47)	5.59
0	(29)	3.28
5	(23)	2.54
10	18.5	1.99
15	15.0	1.57

20	12.2	1.25
25	10.0	1.00
30	8.3	0.80
35	6.8	0.65
40	5.7	0.53
50	4.1	0.36
60	2.9	0.25
70	2.2	-
80	1.6	-

01-269



Test step 3 - Fresh air blower -V2- and Control module for fresh air blower -J126-

Switch VAG 1526 multimeter to test mode:

Voltage measurement (20 V =)

- VAG 1598/11 adapter cable connected

Test step	VAG 1598 socket	Test of	<ul style="list-style-type: none"> • Test requirements - Additional operations 	Specified value	Corrective actions for deviation from specification
3.1	12 and Ground (GND)	Control module for fresh air blower - J126-	<ul style="list-style-type: none"> • Ignition switched on. 	<ul style="list-style-type: none"> - Voltage less than 5 volt. - Fresh air blower not running. 	<ul style="list-style-type: none"> - Locate and repair short circuit to B+ in wiring connection between Control module for fresh air blower -J126- and A/C Control Head -E87- according to wiring diagram. - Replace Control module for fresh air blower -J126-.

3.2	6 and Ground (GND)	Voltage supply for Fresh air blower -V2-	<ul style="list-style-type: none">• Ignition switched on.	- approx. battery voltage	- Repair voltage supply according to wiring diagram.
-----	--------------------	--	---	---------------------------	--

Notes:

◆ *Ground is at, for example, connector -D-, socket 14 and 15.*

◆ *On vehicles with sun roof solar cells observe wiring diagram for voltage supply of Fresh Air Blower -V2- (voltage is supplied to -V2- via separation relay).*

⇒ *Electrical Wiring Diagrams, Troubleshooting & Component Locations*

01-270



Switch VAG 1526 multimeter to test mode:

Voltage measurement (20 V =)

- VAG 1598/11 adapter cable connected

Test step	VAG 1598 socket	Test of	<ul style="list-style-type: none"> Test requirements - Additional operations	Specified value	Corrective actions for deviation from specification
3.3	14 and Ground (GND)	Voltage supply for Control module for fresh air blower - J126- (via Fresh air blower -V2-)	<ul style="list-style-type: none"> Ignition switched on. 	- approx. battery voltage	- Repair voltage supply according to wiring diagram.

VAG 1527 voltage tester

- VAG 1598/11 adapter cable connected

3.4	6 and 12	Control module for fresh air blower - J126-	- Ignition switched on.	<p>- LED on voltage tester lights.</p> <p>- Fresh air blower runs</p>	<p>- Determine and eliminate open circuit in wiring connection between Control module for fresh air blower -J126- and A/C Control Head - E87-, according to wiring diagram.</p> <p>- Ensure V2- moves freely.</p> <p>- Replace Control module for fresh air blower -J126-.</p>
-----	----------	---	-------------------------	---	--

Note:

Ground is at, for example, connector -D-, socket 14 and 15.

01-271



Test step 4 - Air conditioner positioning motors with potentiometers

Switch VAG 1526 multimeter to test mode:

Resistance measurement (20 K Ω)

- VAG 1598/11 adapter cable connected

Test step	VAG 1598 socket	Test of	<ul style="list-style-type: none"> Test requirements - Additional operations	Specified value	Corrective actions for deviation from specification
4.1	52 and 34/ 1/ 36/ 2/ 9	Potentiometer (in positioning motor) -G112- (-V70-) -G113- (-V71-) -G135- (-V107-) -G220- (-V158-) -G221- (-V159-)		- greater than 0.1 k Ω and less than 5.7 k Ω (depending on position of positioning motor).	- Locate and repair short, open circuit or contact resistance according to wiring diagram. - Replace positioning motor.

4.2	16 and 34/ 1/ 36/ 2/ 9	Potentiometer (in positioning motor) -G112- (-V70-) -G113- (-V71-) -G135- (-V107-) -G220- (-V158-) -G221- (-V159-)		- greater than 0.1 k Ω and less than 5.7 k Ω (depending on position of positioning motor).	- Locate and repair short, open circuit or contact resistance according to wiring diagram. - Replace positioning motor.
-----	--	---	--	--	--

01-272



Notes:

- ◆ *The resistance value of potentiometer in the positioning motors (Specification: 3.6 k Ω to 5.7 k Ω between terminal 1 and 3) can only be measured directly at the motor (connected in parallel).*

- ◆ *The resistance of the potentiometers in the positioning motors (between terminals 1 and 2 and between terminals 3 and 2) depends on the position of the positioning motor, and must always be measured with the positioning motors installed. The maximum specified value would not be obtained in test step 4.1 and 4.2. To obtain the maximum specified value, all the connectors on the other positioning motors would have to be disconnected (motors are connected in parallel).*

- ◆ *If the A/C Control Head -E87- detects the malfunction "Potentiometer short circuit to Ground (GND)" or "Open/short circuit to B+", check all the potentiometer (one in each of the 5 positioning motors) and the wiring.*

- ◆ *If the read out for the DTC memory shows that more than one of the positioning motors is malfunctioning but no DTCs are identified in the test step 4, test for short circuits in wiring to and between the individual positioning motors (e.g. between -V70- and -V71-).*

01-273



Switch VAG 1526 multimeter to test mode:

Resistance measurement (200 Ω)

- VAG 1598/12 adapter cable connected

Test step	VAG 1598 socket	Test of	<ul style="list-style-type: none"> Test requirements - Additional operations	Specified value	Corrective actions for deviation from specification
4.3	4 and 16	Central Air Flap Motor - V70-		- 20 Ω to 100 Ω .	- Locate and repair short, open circuit or contact resistance according to wiring diagram. - Replace positioning motor.
4.4	5 and 6	Air Flow Flap Motor - V71-		- 20 Ω to 100 Ω .	

01-274



Switch VAG 1526 multimeter to test mode:

Resistance measurement (200 Ω)

- VAG 1598/12 adapter cable connected

Test step	VAG 1598 socket	Test of	<ul style="list-style-type: none"> • Test requirements - Additional operations	Specified value	Corrective actions for deviation from specification
4.5	11 and 12	Defroster Flap Motor -V107-		- 20 Ω to 100 Ω	- Locate and repair short, open circuit or contact resistance according to wiring diagram.
4.6	2 and 10	Actuator for temperature flap left -V158-		- 20 Ω to 100 Ω	- Replace positioning motor.
4.7	3 and 13	Actuator for temperature flap right -V159-		- 20 Ω to 100 Ω	

01-275



Test step 5 - A/C Pressure Switch -F129-, output for "A/C compressor cut-in" and signal indicating "engine temperature too high"

Switch VAG 1526 multimeter to test mode:

Resistance measurement (200 Ω)

- VAG 1598/11 adapter cable connected

Test step	VAG 1598 socket	Test of	<ul style="list-style-type: none"> Test requirements - Additional operations	Specified value	Corrective actions for deviation from specification
5.1	21 and 23	A/C pressure switch -F129- (switch between terminal 1 and 2)	<ul style="list-style-type: none"> Switch ignition off. 	- less than 20 Ω	- Locate and repair open circuit or contact resistance according to wiring diagram ¹⁾ . - Check A/C pressure switch -F129- (⇒ Page 87-57).

1) If measuring value block 1 shows "A/C pressure switch -F129- open" as the compressor cut-off condition:

Check for loose terminals in wiring connection to A/C pressure switch -F129- according to wiring diagram.

- Check activation of Coolant fan -V7- step 1 (⇒ output Diagnostic Test Mode ⇒ [Page 01-79](#)).

- A/C pressure switch -F129- (switch between terminals 3 and 4, check activation of Coolant fan -V7- step 2) (⇒ [Page 87-57](#)).

If no malfunctions can be determined, check pressures in refrigerant circuit.

⇒ *Climate control with refrigerant R134a*

01-276

**VAG 1527 voltage tester****A/C control head -E87- connected at test box ((VAG 1598/11 and /12 adapter cables)**

- VAG 1598/11 adapter cable
connected

Test step	VAG 1598 socket	Test of	<ul style="list-style-type: none"> • Test requirements - Additional operations 	Specified value	Corrective actions for deviation from specification
5.2	Ground (GND) and 43	Signal "Engine temperature too high"	<ul style="list-style-type: none"> • Engine running. 	<ul style="list-style-type: none"> • LED on voltage tester lights (may also flicker slightly). 	<ul style="list-style-type: none"> - Locate and repair short circuit to Ground using wiring diagram. - Eliminate A/C compressor cut-off conditions in instrument cluster.

Notes:

- ◆ Ground is at, for example, connector -D-, socket 14 and 15.

- ◆ *The instrument cluster also transmits the current coolant temperature signal via the same wiring connections. This may cause the LED on the voltage tester to flicker.*

01-277



- ◆ *Coding (allocation) of ignition key is transmitted to the A/C control head -E87- from the instrument cluster along with the coolant temperature and the signal "engine temperature too high" when ignition is switched on for vehicles from m.y. 2000 (data message). Coding of key can only be processed by A/C control heads -E87- with part number 8D0 820 043 with index "H", "J", "K" or "L" as well from index "T" and with index "AE", "AF", "AG" and "AH". No information can be transmitted if the coolant temperature is too high.*

- ◆ *When ignition is switched on, A/C control head -E87- begins with the setting that was valid when the ignition was last switched off with this key (temperature, air distribution, fresh air blower RPM).*

- ◆ *The instrument cluster can only be transmit the coding of the ignition key on vehicles equipped with immobilizer.*

⇒ *Repair Manual, Electrical Equipment, Repair Group 90, Instruments, Instrument cluster*

- ◆ *The signal from instrument cluster (data message) cannot be checked with workshop tools..*

⇒ *Repair Manual, Electrical Equipment, Repair Group 90, Instruments, Instrument cluster*

01-278

**VAG 1527 voltage tester****A/C control head -E87- connected at test box ((VAG 1598/11 and /12 adapter cables)**

- VAG 1598/11 adapter cable
connected

Test step	VAG 1598 socket	Test of	<ul style="list-style-type: none"> • Test requirements - Additional operations 	Specified value	Corrective actions for deviation from specification
5.3	6 and 15	Output for "A/C compressor cut-in"	<ul style="list-style-type: none"> • Engine running. • Compressor switched off (indicator light in ECON button lights up). - Switch compressor on. 	<ul style="list-style-type: none"> - LED on voltage tester lights. - LED on voltage tester becomes slightly dimmer. 	<ul style="list-style-type: none"> - Locate and repair short circuit or open circuit according to wiring diagram. - Eliminate A/C compressor cut-off condition in engine management system (emergency running mode). <p>⇒ <i>Repair Manual, Fuel Injection & Ignition, Repair Group 01</i></p>

- Locate and repair short circuit to Ground using wiring diagram.

01-279



Switch VAG 1526 multimeter to test mode:

Current measurement (200 mA =)

A/C control head -E87- connected at test box ((VAG 1598/11 and /12 adapter cables)

- VAG 1598/11 adapter cable connected

Test step	VAG 1598 socket	Test of	<ul style="list-style-type: none"> Test requirements - Additional operations	Specified value	Corrective actions for deviation from specification
5.4	Ground (GND) and 15	Output for "A/C compressor cut-in"	<ul style="list-style-type: none"> Engine running. Compressor switched off. - Switch compressor on. - Disconnect VAG 1526 connector leads from sockets.	- less than 5 mA - less than 5 mA - Compressor does not switch on. - Compressor should switch on.	- Locate and repair short circuit to B+ using wiring diagram. - Replace A/C control head -E87-.

- Locate and repair compressor cut-off condition in engine control module or Transmission Control Module (TCM) -J217-. Transmission Control Module (TCM) -J217

⇒ *Repair Manual, Fuel Injection & Ignition, Repair Group 01*

- Locate and repair short circuit to Ground using wiring diagram.

01-280

**Note:**

Ground is at, for example, connector -D-, socket 14 and 15.

Test step 6 - Voltage supply for A/C clutch -N25-, activation of Coolant fan -V7- and activation of A/C clutch -N25- Activation of A/C clutch -N25-)

Switch VAG 1526 multimeter to test mode:

Voltage measurement (20 V =)

- VAG 1598/11 adapter cable connected

Test step	VAG 1598 socket	Test of	<ul style="list-style-type: none"> • Test requirements - Additional operations 	Specified value	Corrective actions for deviation from specification
6.1	23 and Ground (GND)	Voltage supply for A/C clutch	<ul style="list-style-type: none"> • Ignition switched on. 	- Approx. battery voltage	- Check for short circuit or contact resistance in voltage supply according to wiring diagram and repair.

Note:

Ground is at, for example, connector -D-, socket 14 and 15.

01-281



Switch VAG 1526 multimeter to test mode:

Current measurement (20 A =)

- VAG 1598/11 adapter cable connected

Test step	VAG 1598 socket	Test of	<ul style="list-style-type: none"> Test requirements <p>- Additional operations</p>	Specified value	Corrective actions for deviation from specification
6.2	32 and Ground (GND)	Activation of Coolant fan - V7- stage 1	<ul style="list-style-type: none"> Ignition switched on. <p>- Start engine (only on vehicles using Coolant FC (Fan Control) Control Module -J293- to activate the coolant fans)</p>	<p>- less than 1 A</p> <p>- Coolant fan - V7- should run at first speed</p>	<p>- Determine and located open and short circuit to B+ in wiring connection between Coolant Fan control (FC) Relay -J26- (-J293-) and A/C Control Head -E87- according to wiring diagram.</p> <p>- Check activation of Coolant fan -V7- .</p> <p>⇒ <i>Repair Manual, Electrical Equipment On Board Diagnostic</i></p>

(OBD), Repair Group
01.

Notes:

- ◆ *Check activation of Coolant fan -V7- (step 2 via A/C pressure switch -F129-) (⇒ [Page 87-57](#)).*

- ◆ *The coolant fan is switched to second speed via Second Speed Coolant Fan Control (FC) Relay -J101- (Coolant FC (Fan Control) Control Module -J293-):- when Coolant Fan Control (FC) Thermal Switch -F18 is closed.- when A/C pressure switch -F129- is closed (switch between terminal 3 and 4).*

- ◆ *Depending on engine type, the coolant fan may also be activated via -J293- instead of the relay, there can be also 2 or 3 coolant fans installed.*

01-282



Switch VAG 1526 multimeter to test mode:

Current measurement (20 A =)

- VAG 1598/12 adapter cable
connected

Test step	VAG 1598 socket	Test of	<ul style="list-style-type: none"> • Test requirements - Additional operations 	Specified value	Corrective actions for deviation from specification
6.3	8 and 14	Activation of A/C clutch -N25-	<ul style="list-style-type: none"> • Engine running 	<ul style="list-style-type: none"> - less than 1 A - Compressor should run. 	<ul style="list-style-type: none"> - Determine and locate open and short circuit to B+ in wiring connection between A/C Clutch Relay -J44- (-J293-) and A/C Control Head -E87- according to wiring diagram.

- Determine and eliminate open circuit in voltage supply or in wiring connection to A/C Clutch Relay -J44- according to wiring diagram.

Continuation (next page)

01-283



Test step	VAG 1598 socket	Test of	<ul style="list-style-type: none"> • Test requirements - Additional operations 	Specified value	Corrective actions for deviation from specification
6.3 (Continuation):					<ul style="list-style-type: none"> - Determine and eliminate open circuit in wiring connection between A/C Clutch Relay -J44- and A/C clutch -N25-, according to wiring diagram. - Check A/C clutch relay -J44-, replace if necessary. - Check A/C clutch - N25-, repair if necessary.

01-284



Test step 7 - Outputs and inputs for certain vehicle equipment with diesel engine/for solar sunroof (not for USA)

VAG 1527 voltage tester

- VAG 1598/11 adapter cable connected

Test step	VAG 1598 socket	Test of	<ul style="list-style-type: none"> • Test requirements - Additional operations 	Specified value	Corrective actions for deviation from specification
7.1	13 and Ground (GND)	not for USA (signal for auxiliary heating)	<ul style="list-style-type: none"> • 		

01-285



Switch VAG 1526 multimeter to test mode:

Current measurement (20 A =)

- VAG 1598/11 adapter cable
connected

Test step	VAG 1598 socket	Test of	<ul style="list-style-type: none"> • Test requirements - Additional operations 	Specified value	Corrective actions for deviation from specification
7.2	13 and Ground (GND)	not for USA			

01-286

Switch VAG 1526 multimeter to test mode:
Voltage measurement (20 V =)

- VAG 1598/12 adapter cable
connected

Test step	VAG 1598 socket	Test of	<ul style="list-style-type: none"> • Test requirements - Additional operations 	Specified value	Corrective actions for deviation from specification
7.3	1 and 14	not for USA			

01-287



Switch VAG 1526 multimeter to test mode:

Voltage measurement (20 V =)

- VAG 1598/11 adapter cable connected

Test step	VAG 1598 socket	Test of	<ul style="list-style-type: none"> Test requirements <p>- Additional operations</p>	Specified value	Corrective actions for deviation from specification
7.4	50 and Ground (GND)	Maintained voltage supply (only on vehicles with solar roof)	<ul style="list-style-type: none"> Ignition switched on. <p>- Switch off ignition.</p>	<p>- Approx. battery voltage</p> <p>- Voltage remains for approximately 20 seconds, then drops to approx. 0 volt</p>	<p>- Check for short circuit or contact resistance in voltage supply according to wiring diagram and repair.</p> <p>- Locate and repair open circuit in voltage supply to solar cell separation relay - J309- according to wiring diagram.</p>

- Replace -
J309-.

Notes:

- ◆ *Ground is at, for example, connector -D-, socket 14 and 15.*
- ◆ *The A/C control head -E87- receives its voltage supply only via terminals 15, so when the ignition is switched off all the positioning motors remain in their current positions. However, in order to ventilate the vehicle interior when the system is in solar ventilation mode, the fresh air/recirculated air flap must be in the "fresh air" position. For this reason, on vehicles with solar sunroof, Solar Cell Separation Relay -J309- continues to supply the A/C control head -E87- with power for a pre-defined period after the ignition has been switched off (maintained voltage supply).*



Electrical testing (vehicles from model year 2002)

Notes:

- ◆ *Connect VAG 1598A test box to vehicle wiring harness ⇒ [Page 01-253](#)*

- ◆ *Observe notes at electrical testing ⇒ [Page 01-253](#) onward.*

- ◆ *The socked assignment on VAG 1598/11 adapter corresponds exactly to the terminal assignment on the A/C Control Head -E87-.*

- ◆ *A variety of information is send via the CAN-bus-Comfort, no electrical testing applies for this information (⇒ [Page 01-166](#) Read measuring value block.*

- ◆ *The following signals are displays as input signals in measuring value block and are not covered in electrical testing (⇒ [Page 01-166](#) Read measuring value block):*

- *Input signal for windshield wiper and windshield washer pump.*

- *Signal for running light and dimming of illumination of A/C Control Head -E87-.*

- *Signal from Sensor for air quality.*

- *Signal for idle speed increase and A/C compressor cut-off from engine control module.*

- *Activation signal for heated front window.*



Electrical tests overview on A/C Control Head -E87-

Test step	Component tested	page
1	◆ Voltage supply, Ground (GND) connection of A/C control head - E87-.	⇒ Page 01-291
2	◆ Outside Air Temperature Sensor -G17- and Fresh Air Intake Duct Temperature Sensor -G89- ◆ Sensor G150-, -G151-, -G191- (and - G263-)	⇒ Page 01-295
3	◆ Fresh air blower with control module -V2-, with Control module for fresh air blower -J126-	⇒ Page 01-299
4	◆ Positioning motors for climate control system and potentiometers -V70-, - G112-, -V107-/-G135-, -V113-/-G143-, -V158-/-G220-, -V159-/-G221- (and - V71-/-G113-)	⇒ Page 01-302
5	◆ Pressure signal from High Pressure Sensor - G65-	⇒ Page 01-309

6

◆ Activation of A/C Compressor Regulator Valve -
N280-

- On vehicle with compressor using A/C Compressor Regulator Valve -
N280-

⇒ [Page 01-317](#)



Test step	Component tested	page
7	<ul style="list-style-type: none">◆ Activation of A/C Clutch Relay - J44-.- Only on vehicles with compressor with A/C Clutch - N25◆ Activation of A/C clutch - N25-- Only on vehicles with compressor with A/C Clutch - N25	⇒ Page 01-324
8	<ul style="list-style-type: none">◆ Activation of Coolant Fan -V7- (step 1 and 2)- Not on vehicle with gas engines with compressor using A/C Compressor Regulator Valve -N280-	⇒ Page 01-329
9	<ul style="list-style-type: none">◆ Signal from Sunlight Photo Sensor - G107-	⇒ Page 01-332

10	<ul style="list-style-type: none">◆ Inputs for signals for activation of A/C control head -E87- (only available with certain vehicle equipment) - Input from auxiliary heater for activation of A/C control head - E87-. - Input for signal to maintain voltage (on vehicles with solar sunroof)	⇒ Page 01-334
11	<ul style="list-style-type: none">◆ Output for signal request of auxiliary heater (not for USA)	



Test step 1 to 4

Test step 1: Voltage supply, Ground (GND) connection of A/C control head -E87-.

VAS 5051, Operating mode Test Instruments: Multi-meter, voltage measurement (20 V =)

- VAG 1598/12 adapter cable connected

Test step	VAG 1598 A socket	Test of	<ul style="list-style-type: none"> • Test requirements - Additional operations 	Specified value	Corrective actions for deviation from specification
1.1	9 + 14	◆ Terminal "15" and Ground (GND) connection on A/C Control Head - E87-	<ul style="list-style-type: none"> • Ignition switched on. 	◆ approx. battery voltage	- Repair voltage supply or Ground (GND) connection according to wiring diagram.

1.2	9 + 15	◆ Terminal "15" and Ground (GND) connection on A/C Control Head - E87-	• Ignition switched on.	◆ approx. battery voltage	- Repair Ground (GND) connection according to wiring diagram
1.3	9 + 15	◆ Terminal "15" on A/C Control Head -E87-	• Ignition switched off	◆ 0 V	- Eliminate short circuit to B+ according to wiring diagram.

01-292

VAS 5051, Operating mode Test Instruments: Multi-meter, voltage measurement (20 V =)

- VAG 1598/11 adapter cable connected

Test step	VAG 1598 A socket	Test of	<ul style="list-style-type: none"> • Test requirements - Additional operations 	Specified value	Corrective actions for deviation from specification
1.4 ²⁾	23 + Ground (GND) ¹⁾	Terminal "75" on A/C Control Head -E87-	<ul style="list-style-type: none"> • Ignition switched on. 	◆ approx. battery voltage	- Repair voltage supply to A/C Control Head -E87- according to wiring diagram

1) The Ground connection can be made via connector -D-, terminal 14.

2) The test step 1.4 should only be carried out on vehicles with A/C Compressor Regulator Valve -N280-. On vehicles with A/C clutch -N25- this connection is checked in test step 7.

01-293

VAS 5051, Operating mode Test Instruments: Multi-meter, voltage measurement (20 V =)

- VAG 1598/11 adapter cable connected

Test step	VAG 1598 A socket	Test of	<ul style="list-style-type: none"> • Test requirements - Additional operations 	Specified value	Corrective actions for deviation from specification
1.5	23 + Ground (GND) ¹⁾	Terminal "75" on A/C Control Head -E87-	<ul style="list-style-type: none"> • Ignition switched off 	◆ 0 V	- Eliminate short circuit to B+ according to wiring diagram.
1.6	49 + Ground (GND) ¹⁾	◆ Ground (GND) connection on A/C Control Head - E87-	<ul style="list-style-type: none"> • Ignition switched on. 	◆ 0 V	- Determine and repair short circuit to B+ in Ground (GND) connection (ground signal) according to wiring diagram

1.7	16 + Ground (GND) ¹⁾	◆ Ground (GND) connection on A/ C Control Head - E87-	• Ignition switched on.	◆ 0 V	- Determine and eliminate short circuit to B+ in 5 volt supply wire (or via connected component) according to wiring diagram
-----	--	--	----------------------------	----------	---

1) The Ground connection can be made via connector -D-, terminal 14.

01-294

VAS 5051, Operating mode Test Instruments: Multi-meter, Resistance measurement (20 k Ω)

- VAG 1598/11 adapter cable connected

Test step	VAG 1598 A socket	Test of	<ul style="list-style-type: none"> • Test requirements - Additional operations 	Specified value	Corrective actions for deviation from specification
1.8	49 + Ground (GND) ¹⁾	◆ Ground (GND) connection on A/C Control Head - E87-	<ul style="list-style-type: none"> • Ignition switched off 	◆ $\infty \Omega$	- Determine and repair short circuit to Ground (GND) in Ground (GND) connection (ground signal) according to wiring diagram
1.9	16 + Ground (GND) ¹⁾	◆ Ground (GND) connection on A/C Control Head - E87-	<ul style="list-style-type: none"> • Ignition switched off 	◆ $\infty \Omega$	

					- Determine and eliminate short circuit to Ground (GND) (vehicle Ground) in 5 volt supply wire (or via connected component and Ground signal to vehicle Ground) according to wiring diagram
1.10	49 + 52	◆ Ground (GND) connection on A/C Control Head - E87-	• Ignition switched off	◆ less than 10 Ω	- Determine and repair open circuit in Ground (GND) connection (ground signal) according to wiring diagram

1) The Ground connection can be made via connector -D-, terminal 14.

01-295



Test step 2: Temperature sensor

VAS 5051, Operating mode Test Instruments: Multi-meter, Resistance measurement (20 k Ω / 200 k Ω)

- VAG 1598/11 adapter cable connected

Test step	VAG 1598 A socket	Test of	<ul style="list-style-type: none"> • Test requirements - Additional operations	Specified value	Corrective actions for deviation from specification
2.1	40 + 49	Fresh Air Intake Duct Temperature Sensor -G89-	<ul style="list-style-type: none"> • Ignition switched off - Measure temperature at installation location of sensor.	<ul style="list-style-type: none"> ◆ Dependent on temperature at installation location of sensor 	- Locate and repair short, open circuit or contact resistance according to wiring diagram.
2.2	29 + 49	Outside air temperature sensor -G17-		Table \Rightarrow Page 01-298	- Replace temperature sensor.

2.3	30 + 49	Sensor for outlet temperature, floor outlet - G192-			
-----	---------------	--	--	--	--

VAS 5051, Operating mode Test Instruments: Multi-meter, Resistance measurement (20 k Ω / 200 k Ω)

- VAG 1598/11 adapter cable connected

Test step	VAG 1598 A socket	Test of	<ul style="list-style-type: none"> • Test requirements - Additional operations	Specified value	Corrective actions for deviation from specification
2.4	10 + 49	Left Vent Temperature Sensor -G150-	<ul style="list-style-type: none"> • Ignition switched off - Measure temperature at installation location of sensor.	<ul style="list-style-type: none"> ◆ Dependent on temperature at installation location of sensor 	- Locate and repair short, open circuit or contact resistance according to wiring diagram.
2.5	31 + 49	Right Vent Temperature Sensor -G151-		Table \Rightarrow Page 01-298	- Replace temperature sensor.

VAS 5051, Operating mode Test Instruments: Multi-meter, Resistance measurement (20 k Ω / 200 k Ω)

- VAG 1598/11 adapter cable connected

Test step	VAG 1598 A socket	Test of	<ul style="list-style-type: none"> • Test requirements - Additional operations	Specified value	Corrective actions for deviation from specification
2.6	28 + 49	Evaporator Vent Temperature Sensor -G263- 2) - On vehicle with compressor using A/C Compressor Regulator Valve -N280-	<ul style="list-style-type: none"> • Ignition switched off - Measure temperature at installation location of sensor.	<ul style="list-style-type: none"> ◆ Depends on temperature on installation location of sensor \Rightarrow Table \Rightarrow Page 01-298 	- Locate and repair short, open circuit or contact resistance according to wiring diagram. - Replace temperature sensor.
		- On vehicles with compressor with A/C Clutch - N25	<ul style="list-style-type: none"> • Ignition switched off 	<ul style="list-style-type: none"> ◆ $\infty \Omega$ 	- Locate and repair short circuit using wiring diagram

2) Evaporator Vent Temperature Sensor -G263- applies only to vehicles with compressor using A/C Compressor Regulator Valve -N280-.

01-298



Temperature depending resistance values of sensor:

Temperature measured at installation location of sensor °C	Resistance value of Outside Air Temperature Sensor - G17- and -G89- kΩ	Resistance value of Left Vent Temperature Sensor -G150-, Right Vent Temperature Sensor -G151- and Sensor for outlet temperature, floor outlet -G192- kΩ	Resistance value of Evaporator Vent Temperature Sensor - G263- kΩ
- 20	9.95	(79.00)	(27.75)
-10	5.59	(47.00)	(15.50)
0	3.28	29.00	9.00
5	2.54	23.20	6.96
10	1.99	18.50	5.44

15	1.57	15.00	4.28
20	1.25	12.20	3.40
25	1.00	10.00	2.72
30	0.80	8.30	2.19
35	0.65	6.80	1.78
40	0.53	5.70	1.46
50	0,36	4,10	1.00
60	0,25	2,90	0.69

01-299



Test step 3

Fresh air blower -V2- and Control module for fresh air blower -J126-

Note:

On vehicles with sun roof solar cells observe wiring diagram for voltage supply of Fresh Air Blower -V2- (voltage is supplied to -V2- via separation relay).

⇒ *Electrical Wiring Diagrams, Troubleshooting & Component Locations*

VAS 5051, Operating mode Test Instruments: Multi-meter, voltage measurement (20 V =)

- VAG 1598/11 adapter cable connected

Test step	VAG 1598 A socket	Test of	<ul style="list-style-type: none"> • Test requirements - Additional operations 	Specified value	Corrective actions for deviation from specification

3.1	12 + Ground (GND) ¹⁾	Control module for fresh air blower - J126-	<ul style="list-style-type: none"> • Ignition switched on. 	<ul style="list-style-type: none"> ◆ Voltage less than 5 volt. ◆ Fresh air blower not running. 	<ul style="list-style-type: none"> - Locate and repair short circuit to B+ in wiring connection between Control module for fresh air blower -J126- and A/C Control Head - E87- according to wiring diagram. - Replace Control module for fresh air blower -J126-.
-----	--	---	---	--	---

1) The Ground connection can be made via connector -D-, terminal 14.

01-300

VAS 5051, Operating mode Test Instruments: Multi-meter, voltage measurement (20 V =)

- VAG 1598/11 adapter cable connected

Test step	VAG 1598 A socket	Test of	<ul style="list-style-type: none"> • Test requirements - Additional operations 	Specified value	Corrective actions for deviation from specification
3.2	6 + Ground (GND) ¹⁾	Voltage supply for Fresh air blower -V2-	<ul style="list-style-type: none"> • Ignition switched on. 	◆ approx. battery voltage	- Repair voltage supply according to wiring diagram.
3.3	14 + Ground (GND) ¹⁾	Voltage supply for Control module for fresh air blower - J126- (via Fresh air blower -V2-)	<ul style="list-style-type: none"> • Ignition switched on. 	◆ approx. battery voltage	- Repair voltage supply according to wiring diagram.

1) The Ground connection can be made via connector -D-, terminal 14.

01-301



VAG 1527 voltage tester

- VAG 1598/11 adapter cable connected

Test step	VAG 1598 A socket	Test of	<ul style="list-style-type: none"> • Test requirements - Additional operations 	Specified value	Corrective actions for deviation from specification
3.4	6 + 12	Control module for fresh air blower - J126-	<ul style="list-style-type: none"> • Ignition switched on. 	<ul style="list-style-type: none"> ◆ LED on voltage tester lights. ◆ Fresh air blower runs 	<ul style="list-style-type: none"> - Determine and eliminate open circuit in wiring connection between Control module for fresh air blower -J126- and A/C Control Head - E87-, according to wiring diagram. - Open circuit in voltage supply or Ground (GND) connection to Control module for fresh air blower -J126- - Make sure Fresh air blower -V2- moves freely.

01-302



Test step 4:

Air conditioner positioning motors with potentiometers

Notes:

- ◆ *The resistance value of potentiometer in the positioning motors (Specification: 3,6 ... 5.7 k Ω between terminal 1 and 3 can only be measured at the motor directly (connected in parallel).*
- ◆ *The resistance of the potentiometers in the positioning motors (between terminals 1 and 2 and between terminals 3 and 2) depends on the position of the positioning motor, and must always be measured with the positioning motors installed. The upper specified value is not attained in test steps 4.1 and 4.2. (In order to reach the upper specified value, all harness connectors from other positioning motors must be disconnected during the measurement (switched in Parallel).*
- ◆ *If the A/C Control Head -E87- detects the malfunction "Potentiometer short circuit to Ground (GND)" or "Open/short circuit to B+", check all the potentiometers and the wiring.*
- ◆ *If DTC memory recognizes several positioning motors as faulty and the malfunction cannot be detected in test step 4, check potentiometers in all positioning motors and the wiring connection between the positioning motors for short circuit (e.g. with harness connectors disconnected between -V107- and -V70- and -E87- between socket 1, 2 and 3 in pertaining connector the tester must read $\infty \Omega$*

⇒ *Electrical Wiring Diagrams, Troubleshooting & Component Locations*

01-303

VAS 5051, Operating mode Test Instruments: Multi-meter, Resistance measurement (20 k Ω)

- VAG 1598/11 adapter cable connected

Test step	VAG 1598 A socket	Test of	<ul style="list-style-type: none"> • Test requirements - Additional operations	Specified value	Corrective actions for deviation from specification
4.1	16 + 2/ 9/ 36/ 34/ 1/ 35 ³⁾	Potentiometer (in positioning motor) -G 220- (-V158-) -G221- (-V159-) -G135 (-V107) -G112- (-V70-) -G143 (-V113) -G113- (-V71-) ³⁾	<ul style="list-style-type: none"> • Ignition switched off 	<ul style="list-style-type: none"> ◆ Greater than 0.1 k Ω and less than 5.7 k Ω (depending on position of positioning motor). 	<ul style="list-style-type: none"> - Locate and repair short, open circuit or contact resistance according to wiring diagram. - Replace positioning motor.

4.2	52 + 2/ 9/ 36/ 34/ 1/ 35 ³⁾	Potentiometer (in positioning motor) -G 220- (-V158-) -G221- (-V159-) -G135 (-V107) -G112- (-V70-) -G143 (-V113) -G113- (-V71-) ³⁾	<ul style="list-style-type: none"> • Ignition switched off 	<ul style="list-style-type: none"> ◆ Greater than 0.1 kΩ and less than 5.7 Ω (depending on position of positioning motor). 	<ul style="list-style-type: none"> - Locate and repair short, open circuit or contact resistance according to wiring diagram. - Replace positioning motor.
-----	---	---	---	---	--

³⁾ Air Flow Flap Motor -V71- with Back Pressure Flap Motor Position Sensor-G113- is only installed in vehicles with left hand steering.

01-304

**Note:**

- ◆ The Air Flow Flap Motor -V71- only is installed on vehicles with left hand steering; it moves the back pressure flap.

VAS 5051, Operating mode Test Instruments: Multi-meter, Resistance measurement (20 kΩ)

- VAG 1598/11 adapter cable connected

Test step	VAG 1598 A socket	Test of	<ul style="list-style-type: none"> • Test requirements - Additional operations 	Specified value	Corrective actions for deviation from specification
4.3	Ground (GND) ¹⁾	Potentiometer (in positioning motor)	<ul style="list-style-type: none"> • Ignition switched off 	◆ ∞ Ω	- Determine and eliminate short circuit to Ground (GND) (vehicle Ground) in Ground signal wire (or via connected component and 5 volt supply wire to vehicle Ground) according to wiring diagram
	+	-G220- (-V158-)			
	2/	-G221- (-V159-)			
	9/	-G135 (-V107)			
	36/	-G112- (-V70-)			
	34/	-G143 (-V113)			

1/
35 3)

-G113- (-V71-) 3)

- Replace
positioning motor.

1) The Ground connection can be made via connector -D-, terminal 14.

3) Air Flow Flap Motor -V71- with Back Pressure Flap Motor Position Sensor -G113- is only installed in vehicles with left hand steering.

⇒ *Electrical Wiring Diagrams, Troubleshooting & Component Locations*

01-305

VAS 5051, Operating mode Test Instruments: Multi-meter, Resistance measurement (200 Ω)

- VAG 1598/12 adapter cable connected

Test step	VAG 1598 A socket	Test of	<ul style="list-style-type: none"> • Test requirements - Additional operations	Specified value	Corrective actions for deviation from specification
4.4	2 + 10	Actuator for temperature flap left -V158-	<ul style="list-style-type: none"> • Ignition switched off 	◆ 20 ... 100 Ω	- Locate and repair short, open circuit or contact resistance according to wiring diagram.
4.5	3 + 13	Actuator for temperature flap right -V159-		◆ 20 ... 100 Ω	- Replace positioning motor.

4.6	5 + 6	Recirculation Flap Motor -V113-	◆ 20 ... 100 Ω
4.7	11 + 12	Defroster Flap Motor -V107-	◆ 20 ... 100 Ω
4.8	4 + 16	Central Air Flap Motor -V70-	◆ 20 ... 100 Ω

01-306

VAS 5051, Operating mode Test Instruments: Multi-meter, Resistance measurement (200 Ω)

- VAG 1598/11 adapter cable connected

Test step	VAG 1598 A socket	Test of	<ul style="list-style-type: none"> • Test requirements - Additional operations	Specified value	Corrective actions for deviation from specification
4.9	24 + 27	Air Flow Flap Motor - V71-.	<ul style="list-style-type: none"> • Ignition switched off 	◆ 20 ... 100 Ω - Left hand steering	- Locate and repair short, open circuit or contact resistance according to wiring diagram. - Replace positioning motor.

Note:

- ◆ *The Air Flow Flap Motor -V71- only is installed on vehicles with left hand steering; it moves the back pressure flaps.*

01-307

VAS 5051, Operating mode Test Instruments: Multi-meter, Resistance measurement (200 Ω)

- VAG 1598/12 adapter cable connected

Test step	VAG 1598 A socket	Test of	<ul style="list-style-type: none"> • Test requirements - Additional operations 	Specified value	Corrective actions for deviation from specification
4.10	14 + 2/ 11/ 4/ 5/ 3	Wiring connection to positioning motors -V158- -V107- Central Air Flap Motor -V70- Recirculation Flap Motor -V113- Actuator for temperature flap right -V159- Short circuit to	<ul style="list-style-type: none"> • Ignition switched off 	◆ $\infty \Omega$	- Eliminate short circuit to Ground (GND) according to wiring diagram.

		Ground (GND)			
VAS 5051, Operating mode Test Instruments: Multi-meter, Resistance measurement (200 Ω)					
<ul style="list-style-type: none"> VAG 1598/11 adapter cable connected 					
4.11	Ground (GND) ¹⁾ + 24	Wiring connection to positioning motors -V71- ³⁾ Short circuit to Ground (GND)	<ul style="list-style-type: none"> Ignition switched off 	◆ ∞ Ω	- Eliminate short circuit to Ground (GND) according to wiring diagram.

1) The Ground connection can be made via connector -D-, terminal 14.

3) Air Flow Flap Motor -V71- is only installed in vehicles with left hand steering.

⇒ *Electrical Wiring Diagrams, Troubleshooting & Component Locations*

01-308

VAS 5051, Operating mode Test Instruments: Multi-meter, voltage test (20 V =)

- VAG 1598/12 adapter cable connected

Test step	VAG 1598 A socket	Test of	<ul style="list-style-type: none"> • Test requirements - Additional operations 	Specified value	Corrective actions for deviation from specification
4.12	14 + 2/ 11/ 4/ 5/ 3	Wiring connection to positioning motors -V158- Defroster Flap Motor -V107- Central Air Flap Motor -V70- Recirculation Flap Motor -V113- Actuator for temperature flap right -V159- Short circuit to B+	<ul style="list-style-type: none"> • Ignition switched on. 	◆ less than 1 V	- Eliminate short circuit to B+ according to wiring diagram.

VAS 5051, Operating mode Test Instruments: Multi-meter, voltage test (20 V =)

- VAG 1598/11 adapter cable connected

4.13	Ground (GND) ¹⁾ + 24	Wiring connection to positioning motors -V71- ³⁾ Short circuit to B+	<ul style="list-style-type: none"> • Ignition switched on. 	◆ less than 1 V	- Eliminate short circuit to B+ according to wiring diagram.
------	---	---	---	-----------------	--

1) The Ground connection can be made via connector -D-, terminal 14.

3) Air Flow Flap Motor -V71- is only installed in vehicles with left hand steering.

01-309



Test step 5 to 9

Test step 5: Pressure signal from High Pressure Sensor -G65-

VAS 5051, Operating mode Test Instruments: DSO (Digital Storage Oscilloscope)

Setting 5V/Div =, 5ms/Div (5Volt DC voltage and 5 milli seconds per unit)

- VAG 1598/11 adapter cable connected

Test step	VAG 1598 A socket	Test of	<ul style="list-style-type: none"> • Test requirements - Additional operations	Specified value	Corrective actions for deviation from specification
5.1	21 + Ground (GND) ¹⁾	Pressure depending square wave signal from High Pressure Sensor -G65-	<ul style="list-style-type: none"> • Ignition switched on. • Motor not running • Outside temperature greater than 20 ° c but less than 35 ° c 	<ul style="list-style-type: none"> ◆ Square wave signal (depending on pressure in refrigerant circuit) ⇒ Page 01-312 	<ul style="list-style-type: none"> • No signal recognizable - Determine and eliminate open circuit, contact resistance or short circuit between A/C control head - E87- and High Pressure Sensor - G65- according to wiring diagram

				<ul style="list-style-type: none">- Duty cycle greater than 16.5 % and less than 50%	<ul style="list-style-type: none">- Check voltage supply and Ground (GND) connection to High Pressure Sensor -G65- ⇒ Page 01-313 .- High Pressure Sensor -G65- faulty
Continued on next page					

1) The Ground connection can be made via connector -D-, terminal 14.

01-310



VAS 5051, Operating mode Test Instruments: DSO (Digital Storage Oscilloscope)

Setting 5V/Div =, 5ms/Div (5Volt DC voltage and 5 milli seconds per unit)

- VAG 1598/11 adapter cable connected

Test step	VAG 1598 A socket	Test of	<ul style="list-style-type: none"> • Test requirements - Additional operations 	Specified value	Corrective actions for deviation from specification
5.1 (Continuation):	21 + Ground (GND) ¹⁾	Pressure depending square wave signal from High Pressure Sensor -G65-	<ul style="list-style-type: none"> • Ignition switched on. • Motor not running • Outside temperature greater than 20 ° C but less than 35 ° C 		<ul style="list-style-type: none"> • Duty cycle less than 5% but greater than 95% - Check voltage supply and Ground (GND) connection to High Pressure Sensor -G65- ⇒ Page 01-313 . - Replace faulty High Pressure Sensor -G65-

					<ul style="list-style-type: none">• Duty cycle greater than 5% but less than 16.5%) <p>- not enough refrigerant in circuit, send vehicle to authorized A/C workshop</p>
Continued on next page					

1) The Ground connection can be made via connector -D-, terminal 14.

01-311



VAS 5051, Operating mode Test Instruments: DSO (Digital Storage Oscilloscope)

Setting 5V/Div =, 5ms/Div (5Volt DC voltage and 5 milli seconds per unit)

- VAG 1598/11 adapter cable connected

Test step	VAG 1598 A socket	Test of	<ul style="list-style-type: none"> • Test requirements - Additional operations 	Specified value	Corrective actions for deviation from specification
5.1 (Continuation):	21 + Ground (GND) ¹⁾	Pressure depending square wave signal from High Pressure Sensor -G65-	<ul style="list-style-type: none"> • Ignition switched on. • Motor not running • Outside temperature greater than 20 ° C but less than 35 ° C 		<ul style="list-style-type: none"> • Duty cycle greater than 50% or less than 16.5%) - Replace faulty High Pressure Sensor -G65- - Malfunction in refrigerant circuit, send vehicle to authorized A/C workshop

1) The Ground connection can be made via connector -D-, terminal 14.

Notes:

- ◆ *If refrigerant circuit is correctly filled the pressure and therefore the duty cycle changes with ambient temperature.*

- ◆ *The duty cycle and the calculated pressure by A/C Control Head -E87- is displayed in the measuring value block ⇒ [Page 01-166](#) (display group 001).*

- ◆ *The signal that is transferred when the pressure in the refrigerant circuit is approximately 5 to 6 bar, corresponds to an approximate duty cycle of 22% (with compressor not engaged, an ambient temperature of 20° C and properly filled refrigerant circuit).*

- ◆ *The signal that is transferred when the pressure in the refrigerant circuit is approximately 16 bar, corresponds to an approximate duty cycle of 50%. This is obtained with the compressor not engaged and under extreme conditions (e.g. very ambient temperatures and a hot engine).*

01-312



Checking pressure signal from High Pressure Switch -G65-

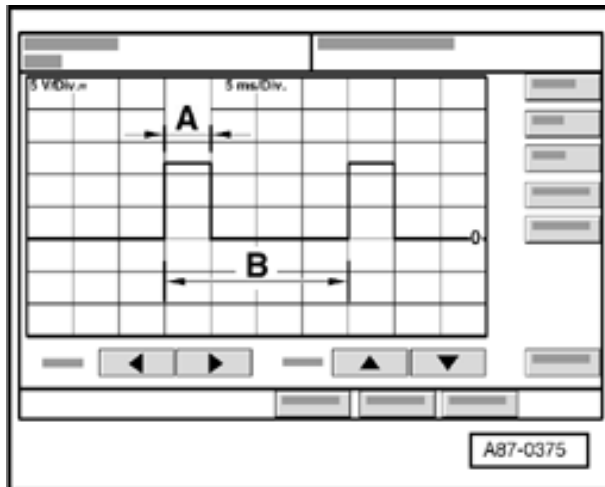

The oscilloscope shows this display when the following conditions are met.

- Ignition switched on (B+ and Ground available at High Pressure Switch -G65-)
- Setting on oscilloscope: 5 V/Div. = (5V per unit DC voltage) 5 ms/Div. (5 Milli seconds per unit)
- Measuring lead (signal lead) connected to socket - 21- of VAG 1598/11 test box.
- Measuring cable (shielded) connected to terminal - 14- on connector -D- of A/C Control Head -E87- or vehicle Ground (GND).

Notes:

- ◆ *The display shows a signal that is transferred when the pressure in the refrigerant circuit is approximately 7 bar, it corresponds to an approximate duty cycle of 25% (with compressor not engaged, an ambient temperature of 30° C and properly filled refrigerant circuit).*

- ◆ *The impulse width -A- depends on the pressure in the refrigerant circuit (if pressure increases, area - A- is getting wider).*

01-313

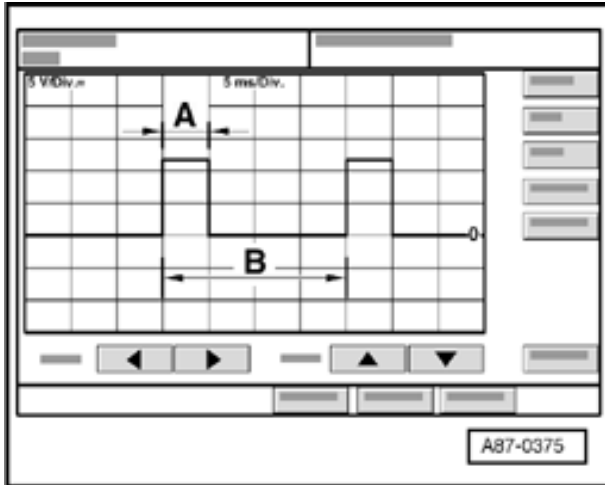

- ◆ *The signal distance -B- is always 20 milli seconds (corresponds to frequency of 50 Hertz).*
- ◆ *The duty cycle is determined by the ratio of impulse width -A- and signal distance -B-.*

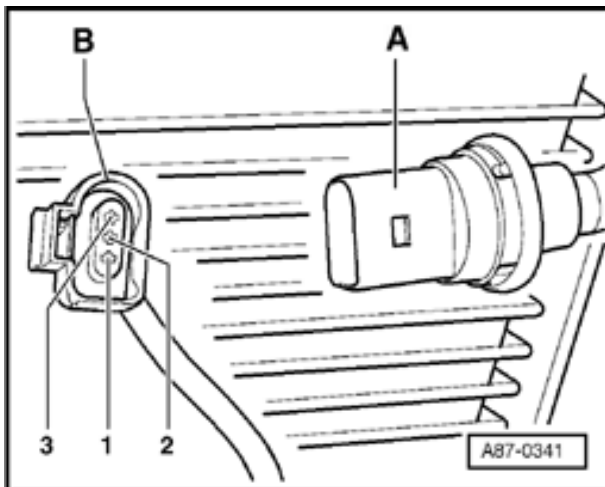

Connector assignment at High Pressure Switch - G65-

Terminal 1 Ground (GND)

Terminal 2 Signal output (square wave signal to -E87-)

Terminal 3 B+ (terminal 75)

Notes:

- ◆ *With harness connector -B- disconnected, the compressor will not engage.*

- ◆ *The high pressure sensor -A- is an electronic control module, which creates a square wave signal, the duty cycle ratio changes with pressure in the refrigerant circuit ⇒ [Page 01-314](#) .*

01-314



Pressure signal from High Pressure Sensor -G65-

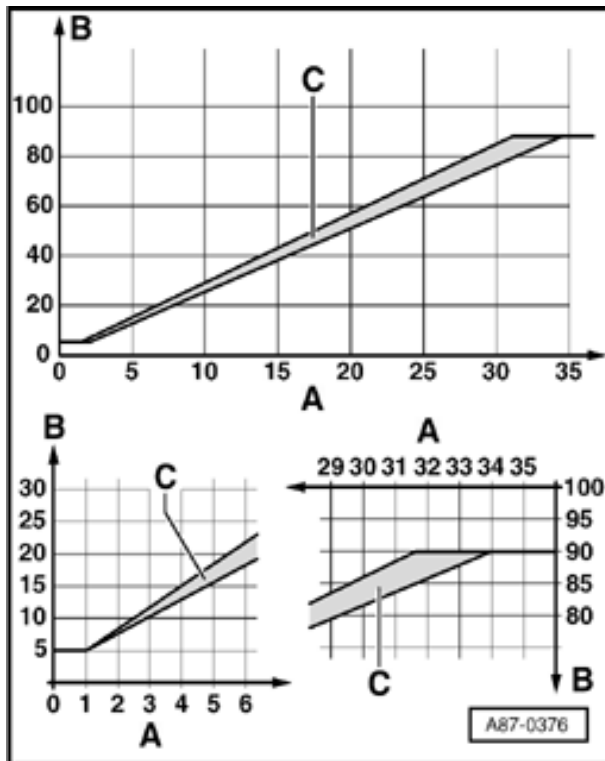

A- Refrigerant system pressure, high pressure side" in bar (absolute pressure)

B- Signal ratio of square wave signal

C- Characteristic curve

Notes:

◆ The A/C control head -E87- switches the compressor on as soon as no compressor cut-off condition exists (by activating the A/C Compressor Regulator Valve -N280- or A/C Clutch Relay -J44-).

- - If the duty cycle is greater than 12% (absolute pressure corresponds approx.; 1.8 bar), if less than 87.5% (pressure corresponds to approx.: 32 bar).

- - The compressor is not switched on if the duty cycle is less than 12 % or greater than 87.5 % (A/C Compressor Regulator Valve -N280- is not activated).

◆ The duty cycle and the calculated pressure by A/C Control Head -E87- is displayed in the measuring value block ⇒ [Page 01-166](#) (display group 001).

- ◆ *At absolute pressure, 0 bar corresponds to absolute vacuum. Normal ambient pressure corresponds to approximately 1 bar absolute pressure. 0 pressure corresponds to an absolute pressure of one bar on most pressure gauges (indicated by -1 below 0).*

01-315



**For vehicles with compressor using A/C
Compressor Regulator Valve -N280- (coding of A/C
control head -E87-)**

- ◆ *The A/C Control Head -E87- sends the request to switch on the coolant fans to the Engine Control Module (ECM) via the CAN-bus system, the ECM switches via the coolant fan control module the coolant fans on.*

- - *Independent from pressure in refrigerant circuit as soon as compressor is switched on.*

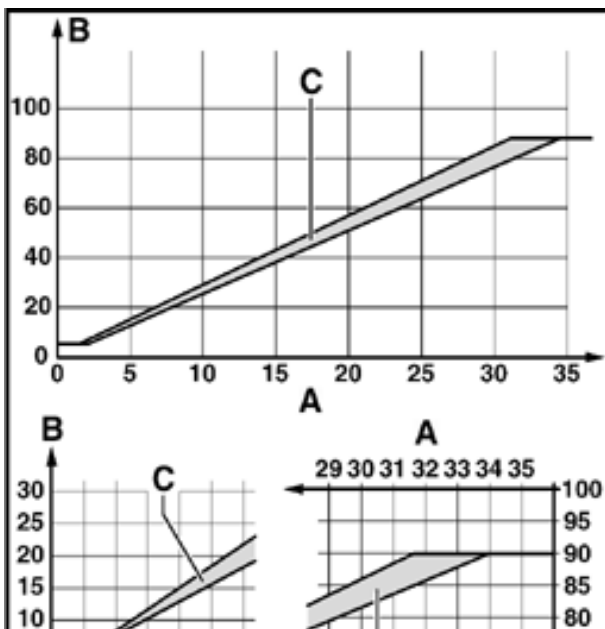

- ◆ *The A/C Control Head -E87- the request for increased coolant fan speed via the CAN-bus system to the Engine Control Module (ECM):*

- - *Vehicles with gas engines request 100% fan speed currently at approx.: 26 bar pressure in the refrigerant circuit.*

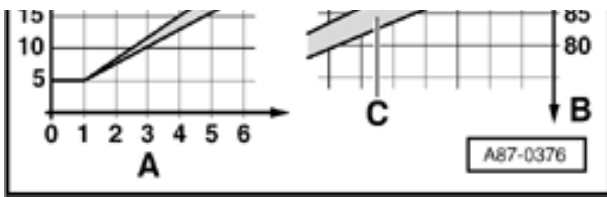

01-316



For vehicles with A/C compressor regulator valve - N280- (coding of -E87-)

◆ *The -E87- switches via a separate wire connection to -J26 and -J101- the coolant fan on:*

- - The first speed independent from pressure in refrigerant circuit as soon as compressor is switched on.

- - The second speed is currently activated at 100 % with a pressure of 16 bar in the refrigerant circuit.

For vehicles with compressors using A/C clutch - N25- (coding of -E87-):

◆ *The A/C Control Head -E87- switches the cooling fan on via a separate wiring connection to Coolant Fan control (FC) Relay -J26- and Second Speed Coolant Fan Control (FC) Relay -J101- or to Coolant FC (Fan Control) Control Module -J293-:*

- - *The first speed independent from pressure in refrigerant circuit as soon as compressor is switched on.*

- - *The second speed is currently activated at 100 % with a pressure of 16 bar in the refrigerant circuit.*

01-317



Test step 6:

Activation for A/C Compressor Regulator Valve -N280-

Notes:

- ◆ *The test step 6 should only be carried out on vehicles with A/C Compressor Regulator Valve - N280-.*

- ◆ *Carry out test step 7 for vehicles with compressors using A/C clutch -N25- (coding of - E87-).*

VAS 5051, Operating mode Test Instruments: Multi-meter, Resistance measurement (200 Ω)

- VAG 1598/12 adapter cable connected

Test step	VAG 1598 A socket	Test of	<ul style="list-style-type: none"> • Test requirements - Additional operations 	Specified value	Corrective actions for deviation from specification

6.1	8 + 14	Wiring connection to A/C Compressor Regulator Valve - N280-	<ul style="list-style-type: none"> • Ignition switched off 	<ul style="list-style-type: none"> ◆ greater than 5 Ω and less than 20 Ω 	<ul style="list-style-type: none"> - Determine and eliminate open circuit or contact resistance in wiring connection between A/C Compressor Regulator Valve - N280- and A/C Control Head - E87-, according to wiring diagram. - Open circuit in A/C Compressor Regulator Valve - N280-, replace compressor
-----	--------------	---	---	---	--

01-318

VAS 5051, Operating mode Test Instruments: Multi-meter, voltage test (20 V =)

- VAG 1598/12 adapter cable connected

Test step	VAG 1598 A socket	Test of	<ul style="list-style-type: none"> • Test requirements - Additional operations 	Specified value	Corrective actions for deviation from specification
6.2	8 + 14	Wiring connection to A/C Compressor Regulator Valve - N280-	<ul style="list-style-type: none"> • Ignition switched off 	◆ less than 1 V	- Locate and eliminate short circuit to B+ in connection to A/C Compressor Regulator Valve - N280- or between - N280- and A/C Control Head -E87- according wiring diagram.

6.3	8 + 14	Voltage supply to A/C Compressor Regulator Valve - N280-	<ul style="list-style-type: none"> • Ignition switched on. 	<ul style="list-style-type: none"> ◆ approx. battery voltage 	<p>- Locate and repair open circuit in voltage supply to A/C Compressor Regulator Valve - N280- according to wiring diagram.</p> <p>- Locate and repair short circuit to Ground (GND) in wiring connection between A/C Compressor Regulator Valve - N280- and A/C Control Head -E87- according to wiring diagram.</p>
-----	--------------	---	---	---	---

01-319

VAS 5051, Operating mode Test Instruments: Multi meter, Current measurement (10 A =)

- VAG 1598/12 adapter cable connected

Test step	VAG 1598 A socket	Test of	<ul style="list-style-type: none"> • Test requirements - Additional operations 	Specified value	Corrective actions for deviation from specification
6.4	8 + 14	Current measurement via A/C Compressor Regulator Valve - N280-	<ul style="list-style-type: none"> • Ignition switched on. 	<ul style="list-style-type: none"> ◆ Greater than 0.5 A and less than 1.5 A 	<ul style="list-style-type: none"> - Determine and eliminate open circuit in wiring connection between A/C Compressor Regulator Valve - N280- and A/C Control Head - E87-, according to wiring diagram. - A/C Compressor Regulator Valve - N280- faulty, replace compressor

Notes:

- ◆ *During operation the compressor performance is dependent on the A/C Compressor Regulator Valve - N280-.*

- ◆ *The A/C Control Head -E87- controls the current that flows through the regulator valve and therefore the compressor performance (output) ⇒ Read measuring value block ⇒ [Page 01-166](#) (display group 001)*

- ◆ *On vehicles with A/C clutch a current of 0.2 A is measured (control current via A/C Clutch Relay - J44-).*

⇒ *Electrical Wiring Diagrams, Troubleshooting & Component Locations*

01-320



Engagement signal for A/C Compressor Regulator Valve -N280-, checking

- Switch ignition off.
- Connect A/C control head to vehicle wiring harness.

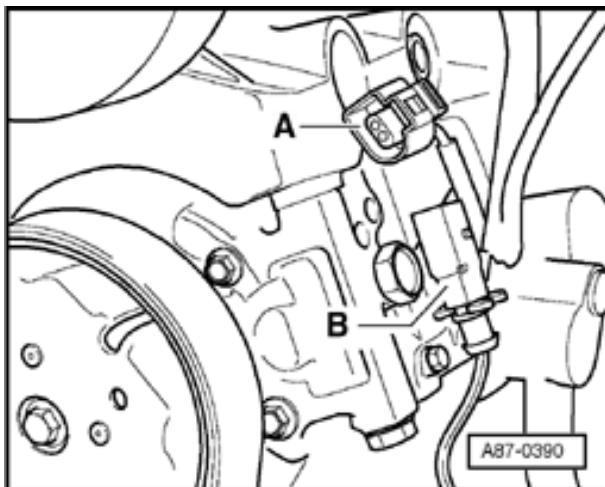

- Disconnect harness connector on A/C compressor.
- Recreate connection to regulator valve between connector -A- and connector -B-, using adapter cable of VAG 1594 A connector test kit.

Note:

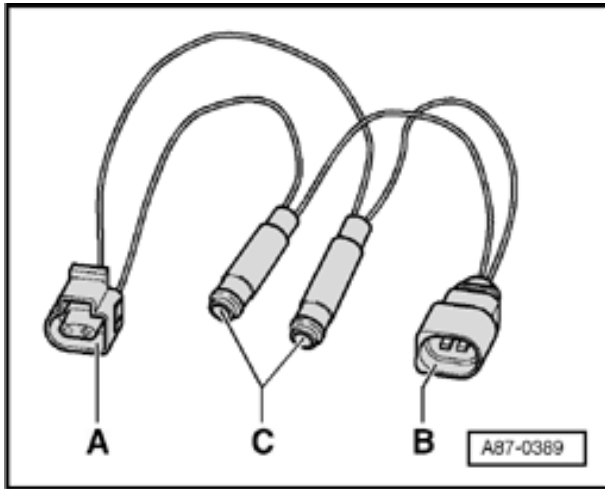

You can create an adapter cable for this test. E.g. use connectors A and B (part number 1J0 973 702 and 1J0 973 802 and relevant terminal contacts), two suitable sockets for connectors C and wires with 0.5 mm² diameter.

01-321

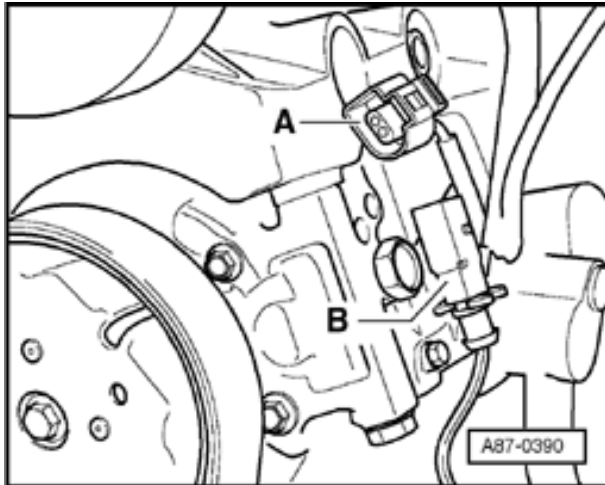

- Connect DSO-measuring cable VAS 5051/8 to two adapter cable.
- Measuring cable (signal wire) to terminal - 2-
- Measuring cable (shielded, ground) to terminal - 1-
- Select operating mode "Test instrument" on VAS 5051: DSO (Digital Storage Oscilloscope) on
- Setting 5V/Div =, 5ms/Div (5 Volt DC voltage and 5 milli seconds per unit)
- Start engine
- Select preset temperature to "Lo" on A/C control head.
- Switch activation of A/C Compressor Regulator Valve -N280- on and off, by pressing the "Auto" and "Econ" button on the A/C Control Head -E87-

01-322



Depending on button pressed on A/C Control Head - E87- the oscilloscope displays:

- During operating mode "OFF" of "Econ"no square wave signal (the regulator valve is not activated).
- During operating mode "Auto" and temperature selection "Lo" a square wave signal with an impulse width -A- between 75% and 100% (the regulator valve is activated)

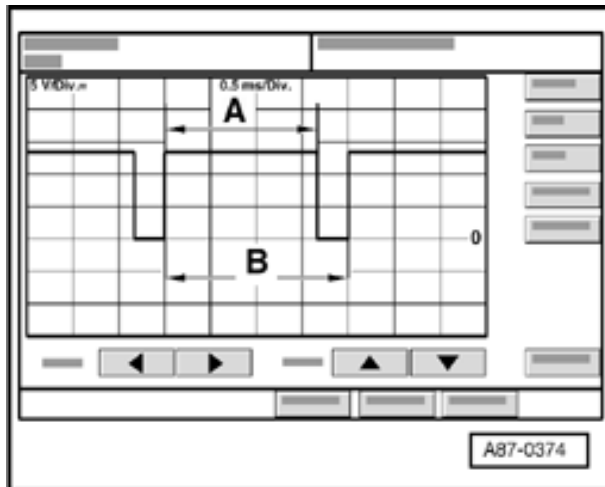

Notes:

- ◆ The illustration shows a signal with a duty cycle ratio of approx. 80%.
- ◆ The impulse width -A- is dependent of the required cooling performance, the vehicle voltage etc. (via the width of range -A- the current is regulated through A/C Compressor Regulator Valve -N280- by the A/C Control Head -E87-.
- ◆ The signal distance -B- is always 2 milli seconds (corresponds to frequency of 500 Hertz).
- ◆ The duty cycle is determined by the ratio of impulse width -A- and signal distance -B-.

- ◆ *In the event that you connect the signal cable to terminal -1- and the cable with the Ground connection to vehicle Ground, a mirror image of the shown signal in illustration A87-0374 appears.*

01-323

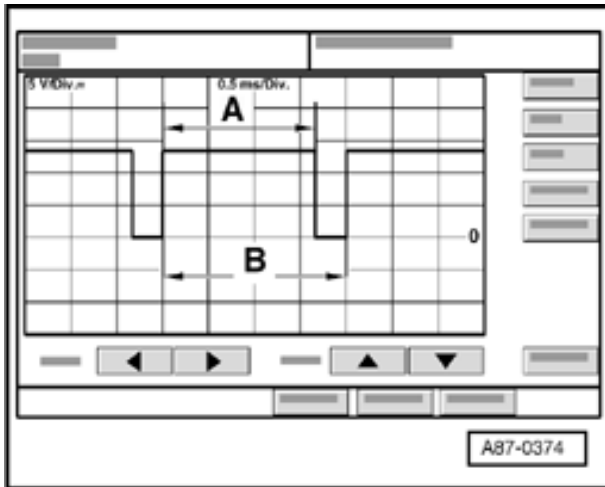

- ↳
- The impulse width of the square wave signal changes depending on A/C Control Head -E87- selection and measured surrounding conditions (duty cycle between 100% and greater than 30%, the control valve is so activated, that the pre-selected temperature is reached (compressor performance is attained).

Notes:

- ◆ *During operating mode "Auto" and temperature selection "Lo" the A/C Compressor Regulator Valve -N280- is activated in such way that the maximum permissible current of 0.65 A flows through -N280- (maximum compressor output).*
- ◆ *In controlled operation, the activation period is dependent on the requested cooling performance, the vehicle voltage etc. The activation period is at least so long that an average current of 0.3 A flows.*

01-324



Test step 7

A/C Clutch Relay -J44- and activation of A/C clutch -N25-

Notes:

- ◆ *The test step 7 should only be carried out on vehicles with A/C clutch - N25-.*

- ◆ *Carry out test step 6 for vehicles with compressors using A/C Compressor Regulator Valve -N280- (coding of - E87-).*

VAS 5051, Operating mode Test Instruments: Multi-meter, voltage test (20 V =)

- VAG 1598/12 adapter cable connected

Test step	VAG 1598 A socket	Test of	<ul style="list-style-type: none"> • Test requirements - Additional operations 	Specified value	Corrective actions for deviation from specification

7.1	8 + 14	A/C clutch relay - J44-	<ul style="list-style-type: none"> • Ignition switched off 	◆ less than 1 V	- Locate and eliminate short circuit to B+ in connection to A/C Clutch Relay -J44- or between -J44- and A/C Control Head -E87- according to wiring diagram.
-----	--------------	-------------------------	---	-----------------	---

01-325

VAS 5051, Operating mode Test Instruments: Multi-meter, voltage test (20 V =)

- VAG 1598/12 adapter cable connected

Test step	VAG 1598 A socket	Test of	<ul style="list-style-type: none"> • Test requirements - Additional operations 	Specified value	Corrective actions for deviation from specification
7.2	8 + 14	A/C clutch relay - J44-	<ul style="list-style-type: none"> • Ignition switched on. 	◆ approx. battery voltage	<ul style="list-style-type: none"> - Locate and repair open circuit in voltage supply to A/C Clutch Relay -J44- according to wiring diagram. - Locate and repair short circuit to Ground (GND) in wiring connection between A/C Clutch Relay -J44- and A/C Control Head -E87- according to wiring diagram. - A/C Clutch Relay - J44- faulty, replace.

01-326

VAS 5051, Operating mode Test Instruments: Multi meter, Current measurement (10 A =)

- VAG 1598/12 adapter cable connected

Test step	VAG 1598 A socket	Test of	<ul style="list-style-type: none"> • Test requirements - Additional operations 	Specified value	Corrective actions for deviation from specification
7.3	8 + 14	Current measurement via A/C Clutch Relay -J44-	<ul style="list-style-type: none"> • Ignition switched on. 	◆ greater than 0.1 A and less than 0.5 A	<ul style="list-style-type: none"> - Determine and eliminate open circuit in wiring connection between A/C Clutch Relay - J44- and A/C Control Head - E87-, according to wiring diagram. - A/C Clutch Relay -J44- faulty, replace.

7.4	No connection created	Activation of A/C Clutch Relay - J44-	<ul style="list-style-type: none"> • Engine running 	<ul style="list-style-type: none"> ◆ Compressor not engaged 	<ul style="list-style-type: none"> - Locate and repair short circuit to B+ in wiring connection between A/C Clutch Relay - J44- - and A/C clutch -N25- according to wiring diagram. - Check A/C clutch relay - J44-, replace if necessary. - Check A/C clutch -N25-, repair if necessary.
-----	-----------------------	---------------------------------------	--	--	--

01-327

VAS 5051, Operating mode Test Instruments: Multi meter, Current measurement (10 A =)

- VAG 1598/12 adapter cable connected

Test step	VAG 1598 A socket	Test of	<ul style="list-style-type: none"> • Test requirements - Additional operations 	Specified value	Corrective actions for deviation from specification
7.5	8 + 14	Activation of A/C Clutch Relay -J44-	<ul style="list-style-type: none"> • Engine running 	<ul style="list-style-type: none"> ◆ greater than 0.1 A and less than 0.5 A ◆ Compressor engaged 	<ul style="list-style-type: none"> - Determine and eliminate open circuit in wiring connection between A/C Clutch Relay -J44- and A/C clutch - N25-, according to wiring diagram. - Locate and repair open circuit in voltage supply to A/C Clutch Relay - J44- according to wiring diagram.

- Open circuit in
Ground (GND)
connection to A/C
Clutch -N25-

- Check A/C clutch
relay -J44-,
replace if
necessary.

- Check A/C clutch
-N25-, repair if
necessary.

01-328

VAS 5051, Operating mode Test Instruments: Multi-meter, voltage test (20 V =)

- VAG 1598/12 adapter cable connected

Test step	VAG 1598 A socket	Test of	<ul style="list-style-type: none"> • Test requirements - Additional operations 	Specified value	Corrective actions for deviation from specification
7.6	23 + Ground (GND) ¹⁾	Voltage supply for A/C clutch relay -J44-	<ul style="list-style-type: none"> • Ignition switched on. 	◆ 0 V	- Locate and eliminate short circuit to B+ in connection to A/C Clutch Relay -J44- or between -J44- and A/C Control Head -E87- according to wiring diagram.

7.7	23 + Ground (GND) ¹⁾	Voltage supply for A/C clutch relay -J44-	<ul style="list-style-type: none"> • Ignition switched on. <p>- Bridge ²⁾ on connector -D- (to A/C Control Head -E87-) between terminal sockets -8- and 14</p>	◆ approx. battery voltage	- Determine and eliminate open circuit in wiring connection between A/C Clutch Relay -J44- and A/C Control Head -E87-, according to wiring diagram.
-----	--	---	--	---------------------------	---

1) The Ground connection can be made via connector -D-, terminal 14.

2) Create bridge with measuring test leads from VAG 1594 A, the A/C Clutch Relay -J44- is activated via this bridge.

⇒ *Electrical Wiring Diagrams, Troubleshooting & Component Locations*

01-329



Test step 8:

Activation of Coolant Fan -V7- (step 1 and 2)

Notes:

- ◆ *Test step 8 should only be carried out on the following vehicles:*

- Vehicles with compressors using A/C Clutch -N25- and -N280-

⇒ *Repair Manual, Fuel Injection & Ignition, Repair Group 01*

- ◆ *On vehicles with gas engines and A/C Compressor Regulator Valve -N280-, the coolant fan is activated by the A/C Control Head -E87- via the CAN-bus system through the respective Engine Control Module (ECM).*

⇒ *Repair Manual, Fuel Injection & Ignition, Repair Group 01*

- ◆ *Depending on engine, the Coolant fan -V7- is activated via Coolant Fan control (FC) Relay -J26- and Second Speed Coolant Fan Control (FC) Relay -J101- or via Coolant FC (Fan Control) Control Module -J293-.*

⇒ *Electrical Wiring Diagrams, Troubleshooting & Component Locations*

◆ *The Coolant fan -V7- is switched to first speed from Coolant Fan control (FC) Relay -J26- /Coolant FC (Fan Control) Control Module -J293-:*

- with Coolant Fan Control (FC) Thermal Switch -F54- closed.

- when A/C Control Head -E87- supplies a Plus signal (as soon as compressor engages).

◆ *The Coolant fan -V7- is switched to second speed by the Second Speed Coolant Fan Control (FC) Relay -J101-/Coolant FC (Fan Control) Control Module -J293-:*

- when Coolant Fan Control (FC) Thermal Switch -F18 is closed.

- when A/C Control Head -E87- supplies a Plus signal (as soon as pressure in refrigerant circuit increases 16 bar).

◆ *On vehicles with Coolant FC (Fan Control) Control Module -J293- and depending on version of -J293-, the coolant fan is switched on only with the engine running (plus at terminal "61").*

⇒ *Electrical Wiring Diagrams, Troubleshooting & Component Locations*

01-330

VAS 5051, Operating mode Test Instruments: Multi meter, Current measurement (10 A =)

- VAG 1598/12 adapter cable connected

Test step	VAG 1598 A socket	Test of	<ul style="list-style-type: none"> • Test requirements - Additional operations 	Specified value	Corrective actions for deviation from specification
8.1	6 + 32	Activation of Coolant fan - V7-, first speed via Coolant Fan control (FC) Relay -J26- or Coolant FC (Fan Control) Control Module - J293-.	<ul style="list-style-type: none"> • Ignition switched on. 	<ul style="list-style-type: none"> ◆ greater than 0.1 A and less than 0.5 A - Coolant fan - V7- runs at first speed (on vehicles with Coolant FC (Fan Control) Control Module - J293- possibly only with engine running). 	<ul style="list-style-type: none"> - Determine and eliminate open circuit in wiring connection between Coolant Fan control (FC) Relay -J26-/ Coolant FC (Fan Control) Control Module -J293- and A/C Control Head - E87-, according to wiring diagram.

- Determine and eliminate open circuit in voltage supply or Ground (GND) connection to -J26-/-J293- according to wiring diagram.

- Check Coolant - J26-/-J293- and replace if necessary.

- Check Coolant Fan -V7-, replace if necessary.

⇒ *Repair Manual, Electrical Equipment On Board Diagnostic (OBD), Repair Group 01.*

01-331

VAS 5051, Operating mode Test Instruments: Multi meter, Current measurement (10 A =)

- VAG 1598/12 adapter cable connected

Test step	VAG 1598 A socket	Test of	<ul style="list-style-type: none"> • Test requirements - Additional operations 	Specified value	Corrective actions for deviation from specification
8.2	6 + 33	Activation of Coolant fan - V7-, second speed via Second Speed Coolant Fan Control (FC) Relay -J101- or Coolant FC (Fan Control) Control Module - J293-.	<ul style="list-style-type: none"> • Ignition switched on. 	<ul style="list-style-type: none"> ◆ greater than 0.1 A and less than 0.5 A - Coolant fan - V7- runs at second speed (on vehicles with Coolant FC (Fan Control) Control Module - J293- possibly only with engine running). 	<ul style="list-style-type: none"> - Determine and eliminate open circuit in wiring connection between J101-/293- and A/C Control Head -E87-, according to wiring diagram. - Determine and eliminate open circuit in voltage supply or Ground (GND) connection to -J101-/-J293- according to wiring diagram.

- Check Second Speed Coolant Fan Control (FC) Relay - J101-/Coolant FC (Fan Control) Control Module - J293- and replace if necessary.

- Check Coolant Fan -V7-, replace if necessary.

⇒ *Repair Manual, Electrical Equipment On Board Diagnostic (OBD), Repair Group 01.*

01-332

**Test step 9:****Sunlight Photo Sensor -G107-****VAS 5051, Operating mode Test Instruments: Multi-meter, voltage test (20 V =)**

- VAG 1598/11 adapter cable connected

Test step	VAG 1598 A socket	Test of	<ul style="list-style-type: none"> • Test requirements - Additional operations	Specified value	Corrective actions for deviation from specification
9.1	25 + Ground (GND) ¹⁾	Wire connection to Sunlight Photo Sensor - G107-	<ul style="list-style-type: none"> • Ignition switched on. 	◆ less than 2 V	- Locate and repair short circuit to B+ using wiring diagram

9.2	26 + Ground (GND) ¹⁾	Wire connection to Sunlight Photo Sensor - G107-	<ul style="list-style-type: none"> • Ignition switched on. 	◆ less than 2 V	- Locate and repair short circuit to B+ using wiring diagram
-----	--	---	---	--------------------	--

1) The Ground connection can be made via connector -D-, terminal 14.

01-333

VAS 5051, Operating mode Test Instruments: Multi-meter, Resistance measurement (20 k Ω)

- VAG 1598/11 adapter cable connected

Test step	VAG 1598 A socket	Test of	<ul style="list-style-type: none"> • Test requirements - Additional operations	Specified value	Corrective actions for deviation from specification
9.3	25 + Ground (GND) ¹⁾	Wire connection to Sunlight Photo Sensor - G107-	<ul style="list-style-type: none"> • Ignition switched on. 	◆ $\infty \Omega$	- Locate and repair short circuit to Ground using wiring diagram
9.4	26 + Ground (GND) ¹⁾	Wire connection to Sunlight Photo Sensor - G107-	<ul style="list-style-type: none"> • Ignition switched on. 	◆ $\infty \Omega$	- Locate and repair short circuit to Ground using wiring diagram

¹⁾ The Ground connection can be made via connector -D-, terminal 14.

01-334

**Test step 10:****Input for engagement signal of A/C Control Head -E87- for vehicles with solar cells****VAS 5051, Operating mode Test Instruments: Multi-meter, voltage test (20 V =)**

- VAG 1598/12 adapter cable connected

Test step	VAG 1598 A socket	Test of	<ul style="list-style-type: none"> • Test requirements - Additional operations	Specified value	Corrective actions for deviation from specification
10.1	1 + 14	not for USA (input signal to -E87-)	<ul style="list-style-type: none"> • 	◆	
10.2	1 + 14	not for USA (signal from auxiliary heating to -E87-)			

Audi A6 Sedan 1998-2004, Audi A6 Avant 1999-2004, Audi allroad quattro 2001-2004, Audi S6 Avant 2002-2004, Audi RS6 2003-2004 - Heating & Air Conditioning

01-335

VAS 5051, Operating mode Test Instruments: Multi-meter, voltage test (20 V =)

- VAG 1598/12 adapter cable connected

Test step	VAG 1598 A socket	Test of	<ul style="list-style-type: none"> • Test requirements - Additional operations	Specified value	Corrective actions for deviation from specification
10.3	50 + Ground (GND) ¹⁾	Maintained voltage supply (only on vehicles with solar roof)	<ul style="list-style-type: none"> • Ignition switched on. - Switch off ignition.	- Approx. battery voltage - Voltage remains for approximately 20 seconds, then drops to approx. 0 volt	- Check for short circuit or contact resistance in voltage supply according to wiring diagram and repair. - Locate and repair open circuit in voltage supply to solar cell separation relay - J309- according to wiring diagram. - Check Solar Cell Separation Relay - J309-, replace if necessary.

1) The Ground connection can be made via connector -D-, terminal 14.

Notes:

- ◆ *The A/C control head -E87- receives its voltage supply only via terminals 15, so when the ignition is switched off all the positioning motors remain in their current positions. However, in order to ventilate the vehicle interior when the system is in solar ventilation mode, the fresh air/recirculated air flap must be in the "fresh air" position. For this reason, on vehicles with solar sunroof, Solar Cell Separation Relay -J309- continues to supply the A/C control head -E87- with power for a pre-defined period after the ignition has been switched off (maintained voltage supply).*

- ◆ *On vehicles with sun roof solar cells observe wiring diagram for voltage supply of Fresh Air Blower -V2- (voltage is supplied to V2- via separation relay).*

01-336



Rear window heating, electrical testing

Special tools, testers and auxiliary items

- VAS 5051 Vehicle Diagnostic, Testing and Information System with current pick up clamp 50A VAS 5051/9 or multi-meter VAG 1715 (with current probe)
- VAG1594 connector test kit

Test requirements

All fuses OK according to wiring diagram.

- Switch off ignition.
- A/C control head -E87- removing ⇒ [Page 87-96](#) .

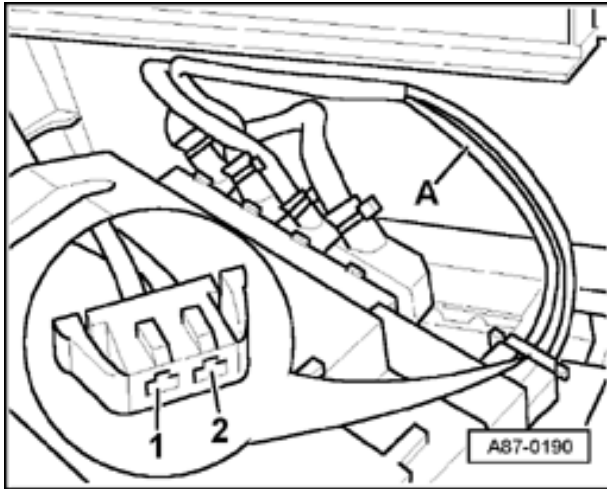

- Disconnect two pin harness connector of A/C Control Head -E87- (identification "F" on A/C Control Head -E87-).
- Switch on ignition.
- Measure voltage between terminals 1 and 2 (specified value: approx. battery voltage).
- Switch off ignition.
- Connect two-pin harness connector to A/C Control Head -E87- (identification "F" on A/C Control Head -E87-).

01-337

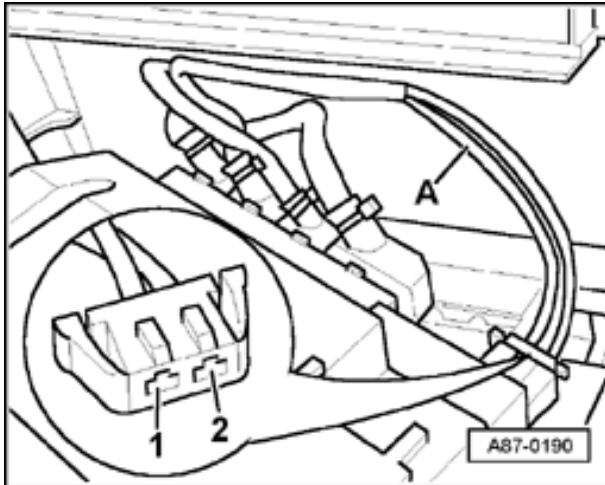

- Route one wire -A- to harness connector "F" through current pick up clamp VAS 5051/9 or VAG1715.

Note:

All harness connectors are connected to the A/C Control Head -E87-.

- Select "Amperage measurement via current pick up" function on VAS 5051 or VAG 1715.
- Start engine.
- Switch rear window heating on via A/C control head - E87- (indicator lamp in button lights up).

The display on VAS 5051 or VAG 1715 will change from less than 25 A to approximately 0 A.

The display will change after about 12 minutes from less than 25 A to approximately 0 A (indicator lamp in button of A/C Control Head -E87- goes out).

Notes:

- ◆ *The current probe may be influenced by stray current which could cause the display to show a low current reading when rear window heating is switched off.*
- ◆ *On vehicles from model year 2002 the activation of heated rear window is displayed in measuring value block 016 (⇒ Read measuring value block ⇒ [Page 01-236](#)).*

01-338



- ◆ *A/C Control Heads without index letter or with index "A", and for control heads "B", "C", "F" and "G" up to and including software version "D54", the A/C Control Head -E87- limits the on-time of the rear window defroster to approx. 12 minutes.*

- ◆ *For A/C control heads with part numbers from index letters "B", "C", "F" and "G" and software version "D55", the rear window defroster remains on until ignition is switched off when outside temperature is less than 0° C (it can be manually switched off at any time). If the temperature increases above 0° C during a driving cycle, the heated rear window will be switched off after the specified operating time - E87-) of approx.: 12 minutes elapsed. The change in production was a running (production implementation from 08.97)*

01-339



Solar sunroof, electrical testing

Notes:

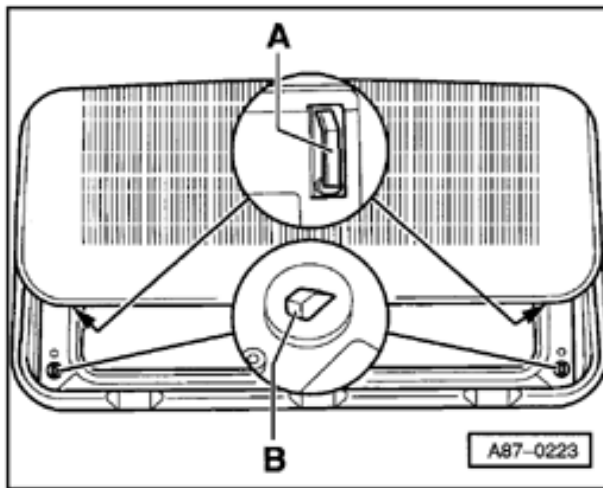

- ◆ *Solar ventilation function only works when the sunroof is either closed or in the raised position. The solar sunroof converts the solar energy into electrical energy which then passes into the vehicle electrical system via terminals A (on the front of the sunroof) and terminals B (on the frame of the sunroof).*
- ◆ *When the ignition is switched on and the auxiliary or auxiliary ventilation is operating, the solar ventilation function cannot be used (Solar Cell Separation Relay -J309- switches the voltage supply for Fresh Air Blower -V2- from Solar Cells -C20- to terminal "30").*

⇒ *Electrical Wiring Diagrams, Troubleshooting & Component Locations*

- ◆ *The A/C control head -E87- receives its voltage supply only via terminals 15, so when the ignition is switched off all the positioning motors remain in their current positions. However, in order to ventilate the vehicle interior when the system is in solar ventilation mode, the fresh air/recirculated air flap must be in the "fresh air" position. For this reason, on vehicles with solar sunroof, Solar Cell Separation Relay -J309- continues to supply the A/C control head -E87- with power for a pre-defined period after the ignition has been switched off (maintained voltage supply).*

01-340



- ◆ *The energy yielded by Solar Cells -C20- is converted by the Control module for solar operation -J355- (located between the sunroof lining and the solar sunroof): for example, from 6.5 volts and 2.5 A into 3.5 volts and 4.6 amps.*
- ◆ *The electrical energy yielded by the solar sunroof when exposed to a solar irradiation level of 500W/m² is around 12W:*

500W/m² (solar irradiation) x 0.21m² (Solar cell surface area on sunroof) x 0.13 (efficiency of solar cells -C20-) x 0.9 (efficiency of Control module for solar operation -J355-).

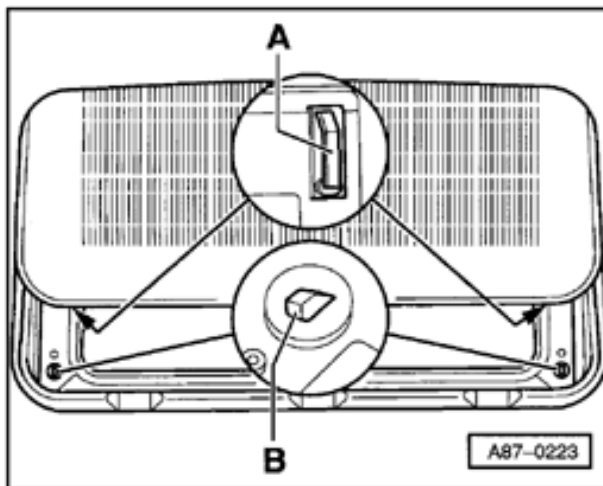

- ◆ *Terminals A and B (on the sunroof and sunroof frame) are used to transfer the electrical energy generated, and must always be clean and free of conventional lubricating grease.*
- ◆ *If necessary, terminals A and B can be lightly coated with contact grease (electrically conductive protective lubricant, available from suppliers of electronic equipment).*

- ◆ *Up to model year 2000 sunroof with 21 solar cells were installed, from model 2000 as a running change sunroofs have converted with 28 solar cells (more efficient)*

01-341

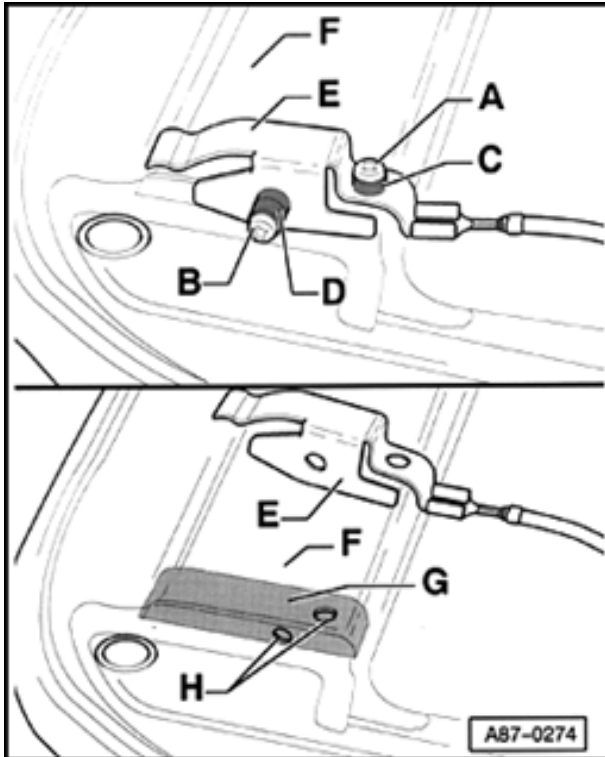

◆ If Control module for solar operation -J355- sends a buzzer signal during day time, indicates this a short circuit:

- - Check wiring connection for short circuit between Control module for solar operation - J355- and contacts -E-.
- - Check both contacts -E- for short circuit to sunroof.
- - Check wiring connection short circuit between contacts of sunroof frame and Fresh Air Blower - V2- (via Solar Cell Separation Relay -J309-).

⇒ Electrical Wiring Diagrams, Troubleshooting & Component Locations

- ◆ The isolating washer -C- and -D- must be installed between bolts -A-, -B- and contact -E-.
- ◆ Glue textile-tape on contact surface -G-, if there is a short circuit between contact E and sunroof -F-, carefully pinch hole in opening -H-.

Testing operation of solar sunroof

- Park vehicle in sun light

01-342



Note:

If weather conditions are unfavorable, the solar sunroof can be illuminated using two commercially available 500 W halogen lamps. These must be set up at a distance of at least 500 mm (19.7 in.) from the surface of the solar sunroof.

- Set climate control so that air is directed to instrument panel air outlets.
- Open center instrument panel air outlet and close all other outlets.
- Switch ignition off (A/C Control Head -E87- goes dark).
- Make sure sunroof is closed.
- Air should be flowing from the instrument panel air outlets (if necessary, check by moistening hand and holding in front of vent).

Notes:

◆ *If Fresh Air Blower -V2- does not work:*

- - *Open sunroof about 10 cm (3.94 in).*

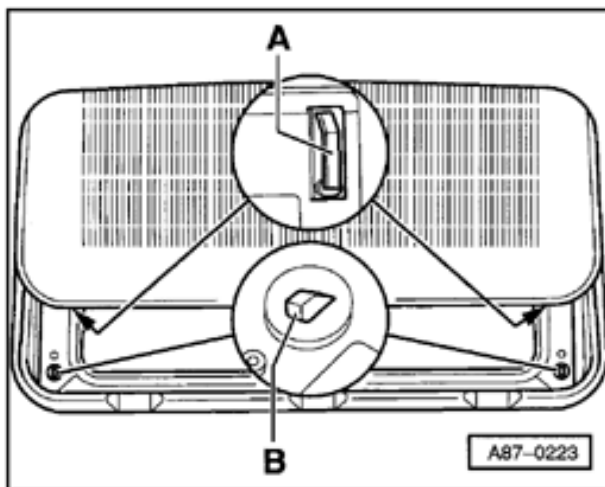

- - *Connect test light (12 volt with maximum 5W) between both contacts -A- of sunroof.*

01-343



- - *The test lamp should glow or light up
(depending of the intensity of the sunlight).*

- If the test lamp glows or lights up, the solar sunroof is functioning properly.

- - *Check wiring to Fresh Air Blower -V2- (via
Solar Cell Separation Relay -J309-).*

⇒ *Electrical Wiring Diagrams, Troubleshooting &
Component Locations*

- ◆ Only a small energy of 1.5 W is supplied when shining a halogen lamps on the solar sunroof (fresh air fan turns, but air flow is hardly recognizable).

01-344



Sensor for air quality -G238-, function

◆ *The sensor for air quality recognizes pollutants in the recirculating air (mostly gasoline and or diesel exhaust) and relies on the A/C Control Head -E87- to switch to the recirculating mode.*

◆ *The A/C Control Head -E87- receives a signal from the Sensor for air quality -G238- from which the type and amount of air pollution is determined. Depending on the outside temperature and the amount of air pollution, the A/C control head then decides:*

- At an outside temperature greater than approx.: + 2° C (36° F) the recirculating air mode is switched on when there is only a slight increase in pollutants. switched in air recirculation mode

- At outside temperature between approx. +2° C and approx. -8° C the change-over to the recirculating air mode is only performed when the pollutant concentration strongly increases (compressor simultaneously switched on).

- At an outside temperature of - 8° C (-18° F) a change over occurs after a severe increase of pollutants concentration, and only for 15 seconds (the compressor is not shut off).

- If the concentration drops, the climate control system switches over to the fresh air mode.

- ◆ *The function "Automatic air recirculation" can be switched off at any time. If the function is active and a request for "Automatic air recirculation" is present the compressor is also switched on when outside temperatures are lower than + 2 ° C. Compressor operation is not possible with temperatures lower than approx. - 8 ° C.*
- ◆ *On vehicles with "Automatic air recirculation", up to a temperature of approx. - 8 ° C the compressor can be switched on when recirculated air was manually switched on (via recirculation button).*
- ◆ *To ensure that the A/C does not operate constantly in the recirculating air mode in areas with a consistently higher pollution, the sensor is self learning (it adjusts its sensitivity to the environmental conditions).*
- ◆ *If outside air pollution load remains high for longer period of time, the sensor starts to adapt itself to the changing environmental condition through an adaptation program (learning program), the air recirculation request in evenly polluted ambient air is therefore generally shorter than 12 minutes. The climate control system may also operate a longer period of time in air recirculation mode, if more load peaks occur after another.*

01-345



- ◆ *A specific amount of time is needed for the A/C flaps to change over. In the event that a sudden increase in pollutants is encountered (e.g. when driving through a diesel exhaust cloud) gas-forming pollutants can be taken in with the fresh air into the passenger compartment until the flaps can be closed. For this reason, a dust- and pollen filter is installed with a charcoal layer. A filter that has become saturated with pollutants is no longer effective and needs to be replaced ⇒ [Page 87-80](#) .*

- ◆ *In order to avoid a quick shifting from the recirculating-/fresh air flap, a slight increase in pollutants entering with recirculating air will not allow for immediate shifting (the sensor does not send a request to A/C Control Head --E87-). The filtering of the charcoal insert in the dust- and pollen filter will be sufficient ⇒ [Page 87-81](#) .*

- ◆ *In order to avoid quick shifting from the recirculating air/fresh air flap, the requirement from the sensor for "Automatic air recirculation" mode is at least 25 seconds (minimum duration period), especially if the pollutant concentration has been reduced considerably so that recirculating air mode is no longer necessary.*

- ◆ *If the compressor is shut-off (e.g. in "Econ" mode) so that the windows do fog up, the maximum duration of the "Automatic air recirculation" mode from A/C control head -E87- is limited to approx. 15 seconds.*

- ◆ *In order to defrost windows as quick as possible, recirculating air mode is not possible with A/C Control Head - E87- in the defrost operating mode.*

- ◆ *The Sensor for air quality -G238- requires approx. 30 seconds to become operational after switching the ignition on (warm-up time). During this time there is no requirement from the sensor to A/C Control Head -E87- for "Automatic air recirculation" mode.*

- ◆ *The Sensor for air quality -G238- contains a highly sensitive electronic component, which can be damaged if it comes in direct contact with solvents, fuels or chemicals. Therefore, do not install sensors which have come in contact with such substances.*

01-346



Sensor for air quality -G238-, checking

Special tools and equipment

- ◆ VAS 5051 Vehicle Diagnostic, Testing and Information System with diagnostic cable VAS 5051/1
- ◆ Test gas D 007 855 A2

Test requirements:

- Vehicle is in area where there is clean recirculating air (not near running engines, openings from exhaust systems, etc.)
- Engine compartment and plenum chamber are clean (not contaminated with oil and/or fuel).
- The engine compartment and plenum chamber were not sprayed with cleaning or preservative solutions.

Checking

- With ignition switched off, connect VAS 5051 Vehicle Diagnostic, Testing and Information System with diagnostic cable VAS 5051/1 to 16-pin diagnostic connector on vehicle ⇒ [Page 01-11](#) .

01-347



- Start engine.
- Check DTC Memory ⇒ [Page 01-18](#)
- Select "Auto" operating mode on A/C Control Head - E87-.
- Press button -A- for "Automatic air recirculation" (LED in -A- button comes on).
- Wait 30 seconds (warm up time of sensor for air quality -G238-).

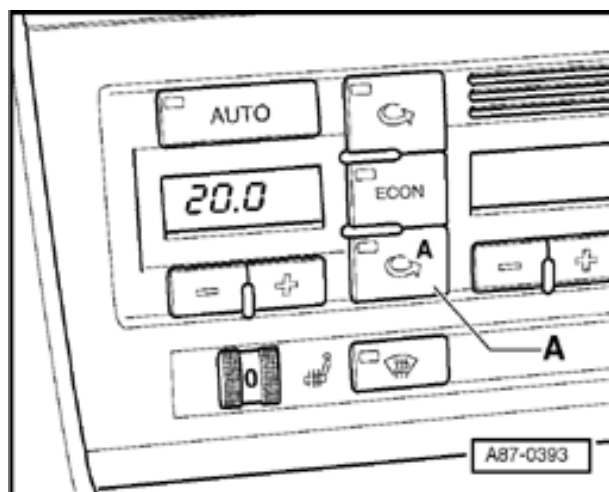

A

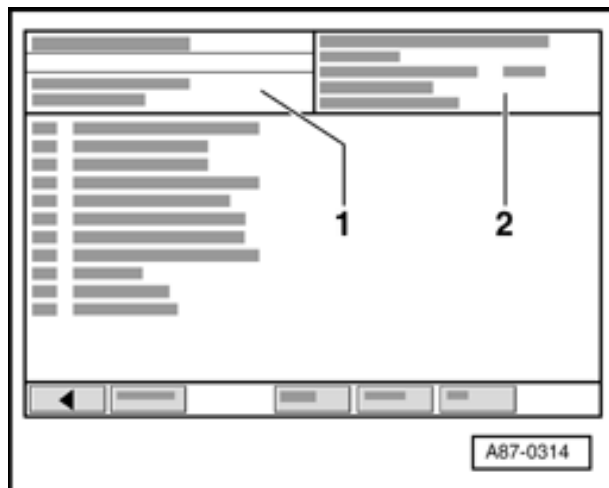

Indicated on display of VAS 5051:

- Press buttons -0- and -8- to select "Read Measuring Value Block" function 08.
- Remove plenum cover.

01-348



Indicated on display of VAS 5051:

- ◆ Display field -1- indicates request to input display group.
- ◆ Display field -2- shows input keyboard.
- Input via keyboard in display field 2 the desired display group number "015" (⇒ overview of selectable display groups ⇒ [Page 01-166](#)).
- Confirm input using the -Q- button.
- Check indications shown in display fields -1- and -2-

Note:

Display field -1- shows the operating conditions of fresh air/recirculation flap and display field -2- indicates the condition of the air quality sensor signal. Clarification of possible displays ⇒ [Page 01-227](#)

01-349



- ◆ Specified value in display field -1-: 00 or 0

(no request for "air recirculation mode", climate control in fresh air mode)

or

- ◆ Specified value in display field -1-: 60

("Partial air recirculation mode", the fresh air/ recirculation flap is so positioned that approx. 1/3 air is sucked in from the passenger compartment)

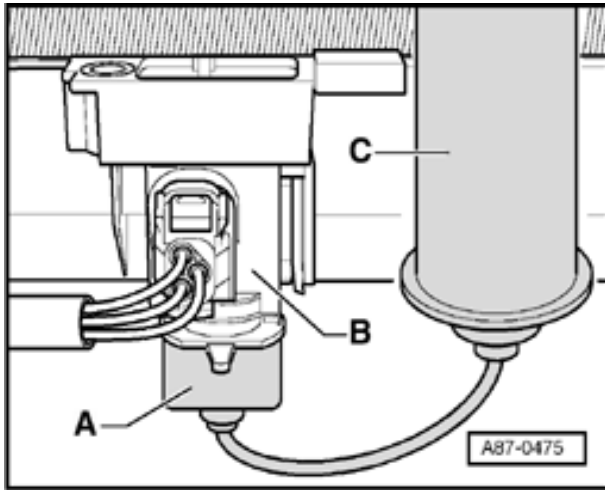

- Place spray head -A- of test bottle over air inlet of sensor for air quality -B-.
- Activate spray head -C- of test bottle for 1 second.

Notes:

- ◆ *The content of the test bottle consists of pure oxygen with a specified amount of nitrogen oxide.*
 - ◆ *If the sensor comes in contact with cigarette smoke or gas from a lighter it will react.*
- Read value indicated in display field - 1-.

01-350



◆ Specification:
10

(request for "Automatic air recirculation"
available, requirement is fulfilled, A/C switches to
air recirculating mode)

- Wait a short period time (approx. 1 minute,
depending on amount of test gas sprayed in sensor).
- Read value indicated in display field -
1-

◆ Specification: 00 or
0

(no request for "air recirculation mode", climate
control in fresh air mode)

or

- ◆ Specification: 60 (Partial air recirculation mode)

Note:

In order to avoid quick shifting from the recirculating air/ fresh air flap, the requirement from the sensor for "Automatic air recirculation" mode is at least 25 seconds (minimum duration period), especially if the pollutant concentration has been reduced considerably so that recirculating air mode is no longer necessary.

01-351



- Operate switch for wiper/washer system until windshield washer pump -V5- has been cycled for approx. 2 seconds.

- Read value indicated in display field - 1-.

- ◆ Specification:
30

(Requirement for recirculating air due to washer/wiper system, A/C switches for approx. 15 seconds to the air recirculating mode)

- Wait a short period time.

- Read value indicated in display field - 1-.

- ◆ Specification: 00 or
0

(no request for "air recirculation mode", climate control in fresh air mode)

or

◆ Specification:
60

(Partial air recirculation mode)

01-352



Notes:

- ◆ *Depending on the composition of the windshield washer fluid, the sensor can determine impurities in the air and request for "Automatic air recirculation".*

- ◆ *If when activating the wiper/washer system the mode does not switch over to recirculating air, check the wiring connection between A/C Control Head -E87- and Wiper/Washer Intermittent Relay - J31- (the information "windshield washing" is send via a separate wiring connection to A/C Control Head -E87-) ⇒ [Page 01-241](#) (Read measuring value block display group 017).*

Note:

If the functions of the Sensor for air quality -G238- is OK for this test and there is a customer complaint continue as follows:

- Check dust and pollen filter for dirt.

- Connect VAS 5051 and select "Read measuring value block" function 08.

01-353



- *A second technician is required because the indicated values must be read out in the vehicle interior.*

- *Observe safety caution notes ⇒ [Page 01-10](#) .*

- *Enter display group number "015".*

- *Drive vehicle to area with relatively clean ambient air (system operates in fresh air mode).*

- *Now drive vehicle into an area with heavily polluted ambient air (e.g. on a street construction or truck traffic).*

- *Check indications shown in display fields -1- and -2- Display fields -1- and -2- must change when driving through a diesel exhaust cloud. Meaning:⇒ Read measuring value block display group 015 (⇒ overview of display groups ⇒ [Page 01-166](#)).*

- *Read notes on ⇒ [Page 87-81](#) and ⇒ [Page 01-344](#) .*

Automatic Climate Control

2001 m. y.

Fuse Panel

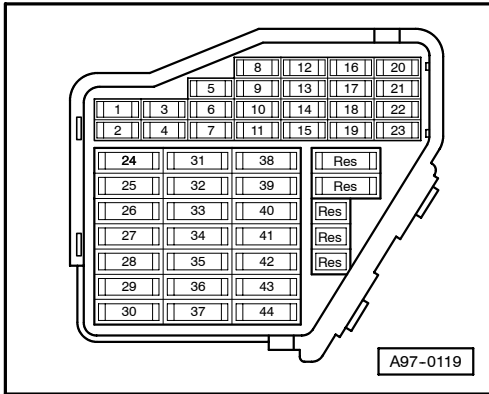

Fuse Colors:

- 30 A - Green
- 25 A - White
- 20 A - Yellow
- 15 A - Blue
- 10 A - Red
- 7,5 A - Brown
- 5 A - Beige

Starting with fuse position 23, fuses in the fuse holder are identified with 223 in the wiring diagram.

Micro Central Electric Panel

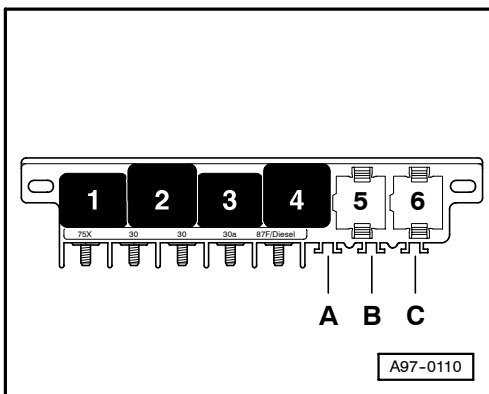

13 - Fold Relay Panel

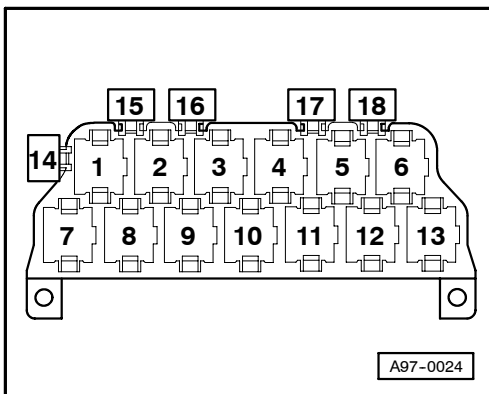

Relay Location:

- 3** -Solar Cell Separation Relay, J309
- 5** -A/C Clutch Relay, J44

8 - Fold Relay Panel

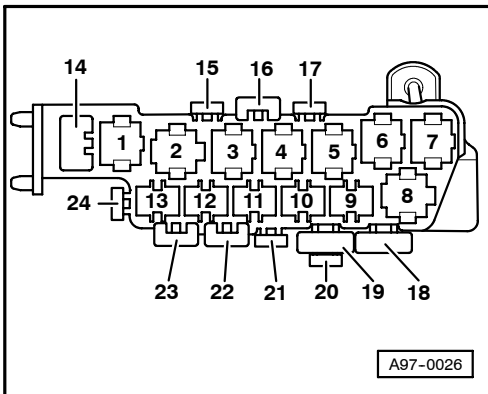

Fuse Location:

- 2** -Second Speed Coolant Fan Control (FC) Relay, J101
- 3** -Coolant Fan control (FC) Relay, J26
- 20** -Coolant Fan Fuse, S42
- 21** -Control module fuse for coolant fan, S142

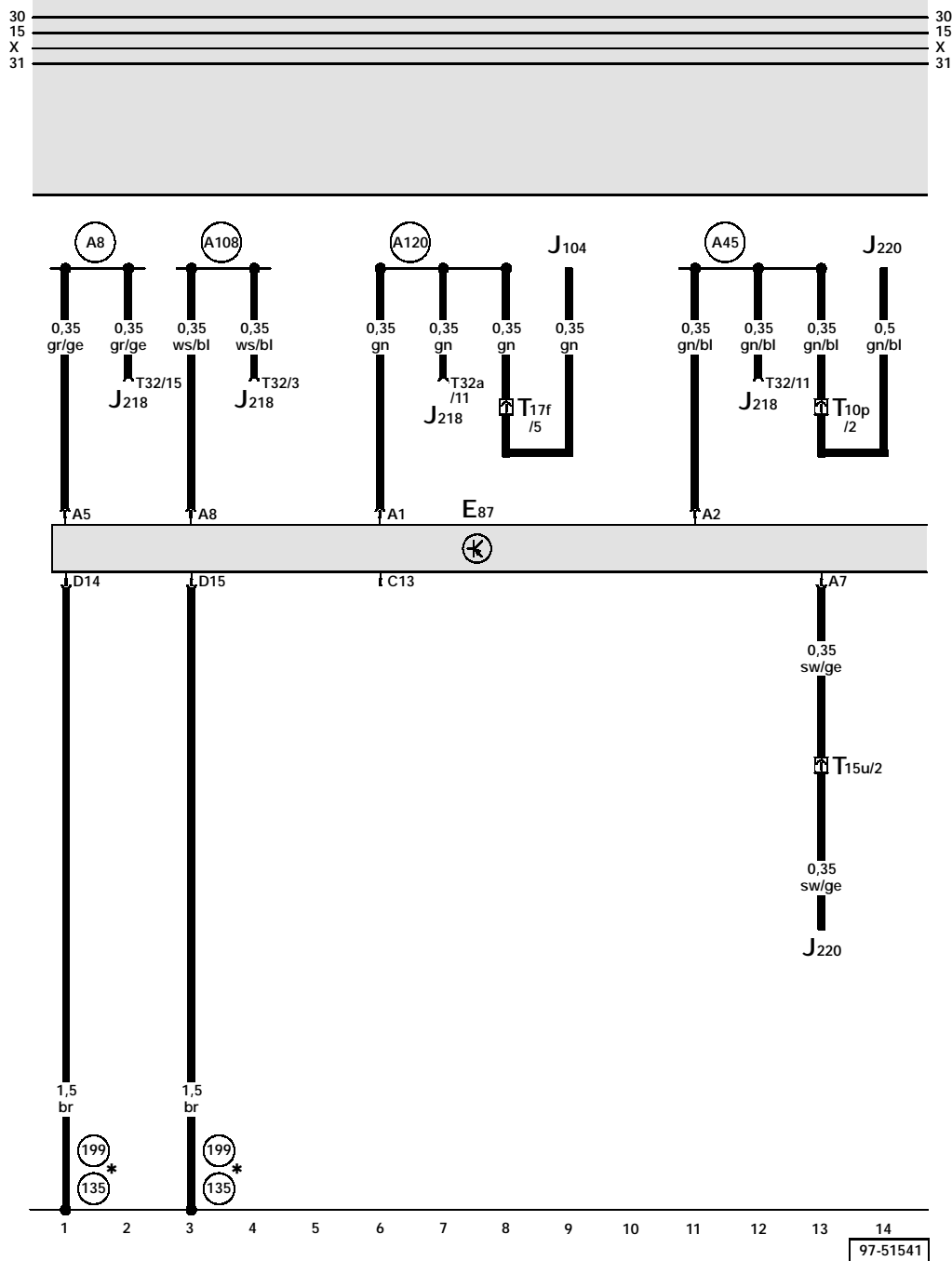

ws = white
 sw = black
 ro = red
 br = brown
 gn = green
 bl = blue
 gr = grey
 li = violet
 ge = yellow

- E87 - A/C Control Head
- J104 - ABS Control Module (w/EDL)
- J218 - Instrument Cluster Combination Processor
- J220 - Motronic Engine Control Module (ECM)
- T10p - Connector 10 pin, black, connector station electronic box plenum chamber
- T15u - Connector 15 pin, red, connector station electronic box plenum chamber
- T17f - Connector 17 pin, black, in 8-Fold Relay Panel behind the storage driver's side
- T32 - Connector 32 pin, blue, on instrument cluster
- T32a - Connector 32 pin, green, on instrument cluster
- (135) - Ground connection -2-, in instrument panel wiring harness
- (199) - Ground connection -3-, in instrument panel wiring harness
- (A8) - Plus connection (58d), in instrument panel wiring harness
- (A45) - Wire connection (RPM-signal), in instrument panel wiring harness
- (A108) - Connector (speed signal), in instrument panel wiring harness
- (A120) - Connection (standing time) in instrument panel wiring harness
- * - both are possible

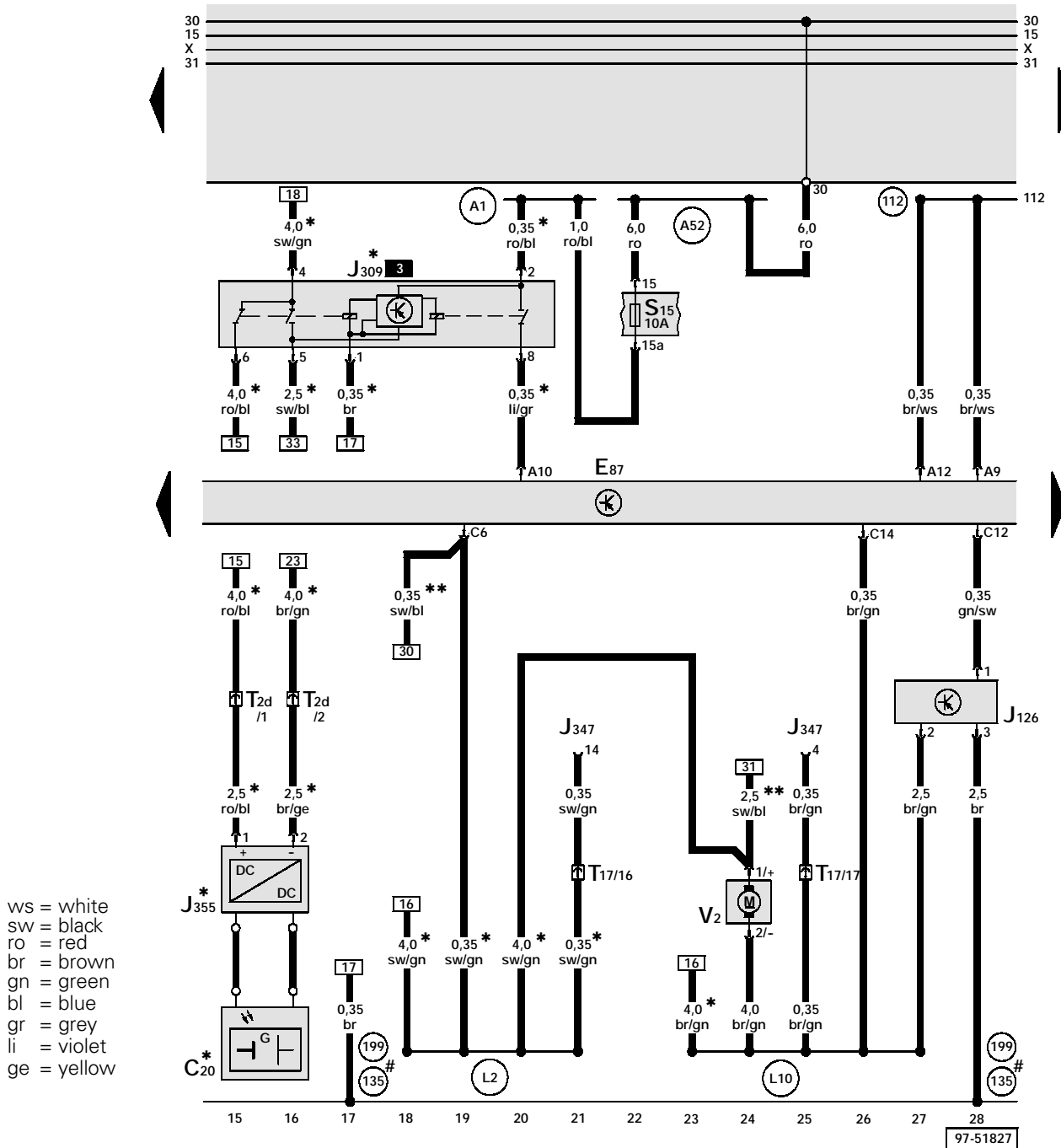

- C20 - Solar Cells
- E87 - A/C Control Head
- J126 - Control module for fresh air blower
- J309 - Solar Cell Separation Relay
- J347 - Control Module for Interior Monitoring sensors
- J355 - Control Module for solar operation
- S15 - Fuse
- T2d - Connector 2 pin, blue, connector station A pillar, left
- T17 - Connector 17 pin, orange, connector station A pillar, right
- V2 - Fresh Air Blower

- (112) - Ground connection -2-, in A/C wiring harness
- (135) - Ground connection -2-, in instrument panel wiring harness
- (199) - Ground connection -3-, in instrument panel wiring harness
- (A1) - Plus connection (30a), in instrument panel wiring harness
- (A52) - Plus connection -2- (30), in instrument panel wiring harness
- (L2) - Wire connection, in A/C wiring harness
- (L10) - Wire connection -2-, in A/C wiring harness

- * - Vehicles with sunroof with Solar Cells
- ** - Vehicles without sunroof with Solar Cells
- # - both are possible

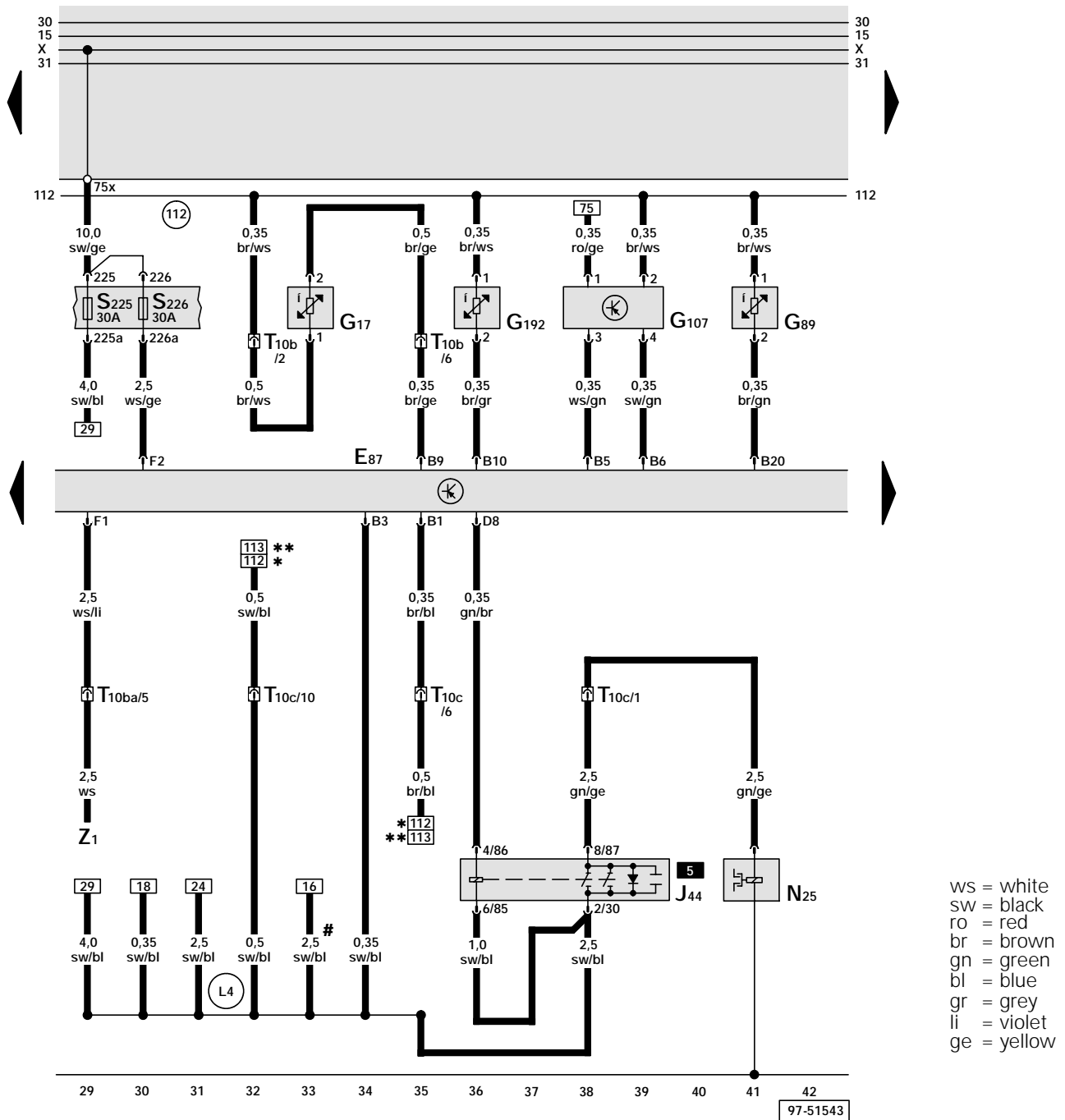

- E87 - A/C Control Head
- G17 - Outside Air Temperature Sensor
- G89 - Fresh Air Intake Duct Temperature Sensor
- G107 - Sunlight Photo Sensor (3241)
- G192 - Sensor for outlet temperature, center
- J44 - A/C Clutch Relay
- N25 - A/C Clutch
- S225 - Fuse 25 in fuse holder
- S226 - Fuse 26 in fuse holder
- T10b - Connector 10 pin, red, connector station A pillar, left
- T10c - Connector 10 pin, grey, connector station A pillar, left
- T10ba - Connector 10 pin, blue, connector station A pillar, left
- Z1 - Rear Window Defogger/Heat Element

- (112) - Ground connection -2-, in A/C wiring harness
- (L4) - Wire connection (75a), in A/C wiring harness

- * - Vehicles with Coolant FC (Fan Control) Control Module
- ** - Vehicles with Coolant Fan Control (FC) Relay
- # - Vehicles with Sunroof with Solar Cells

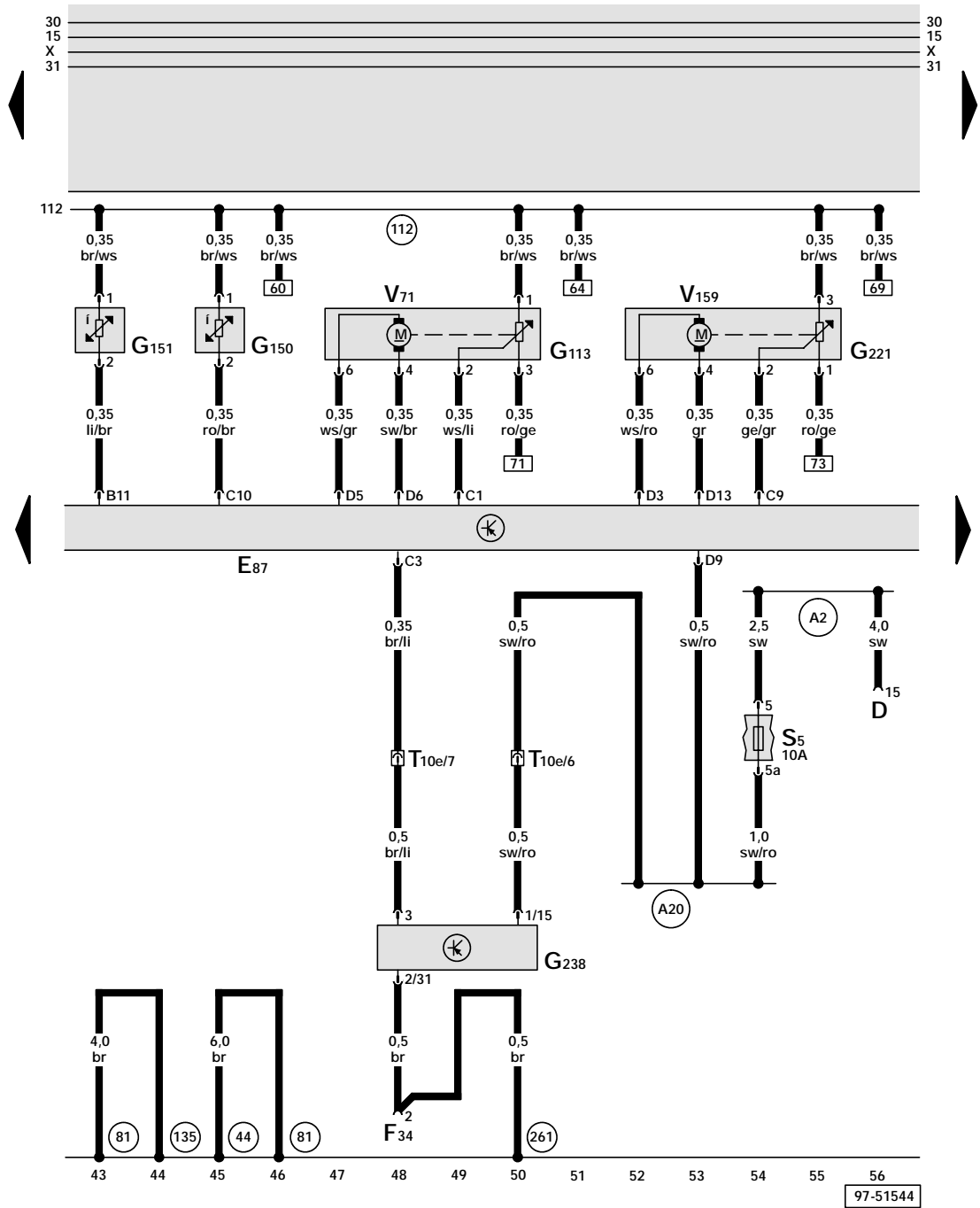

ws = white
sw = black
ro = red
br = brown
gn = green
bl = blue
gr = grey
li = violet
ge = yellow

- D - Ignition/Starter Switch
- E87 - A/C Control Head
- F34 - Brake Fluid Level Warning Switch
- G113 - Back Pressure Flap Motor Position Sensor
- G150 - Left Vent Temperature Sensor
- G151 - Right Vent Temperature Sensor
- G221 - Potentiometer-actuator for temperature flap right
- G238 - Sensor for air quality
- S5 - Fuse
- T10e - Connector 10 pin, violet, connector station A pillar, left
- V71 - Air Flow Flap Motor
- V159 - Actuator for temperature flap right

- 44 - Ground connection, on left A-pillar, lower part
- 81 - Ground connection -1-, in instrument panel wiring harness
- 112 - Ground connection -2-, in A/C wiring harness
- 135 - Ground connection -2-, in instrument panel wiring harness
- 261 - Ground connection, in wiring harness heated spray jet
- A2 - Plus connection (15), in instrument panel wiring harness
- A20 - Wire connection (15a), in instrument panel wiring harness

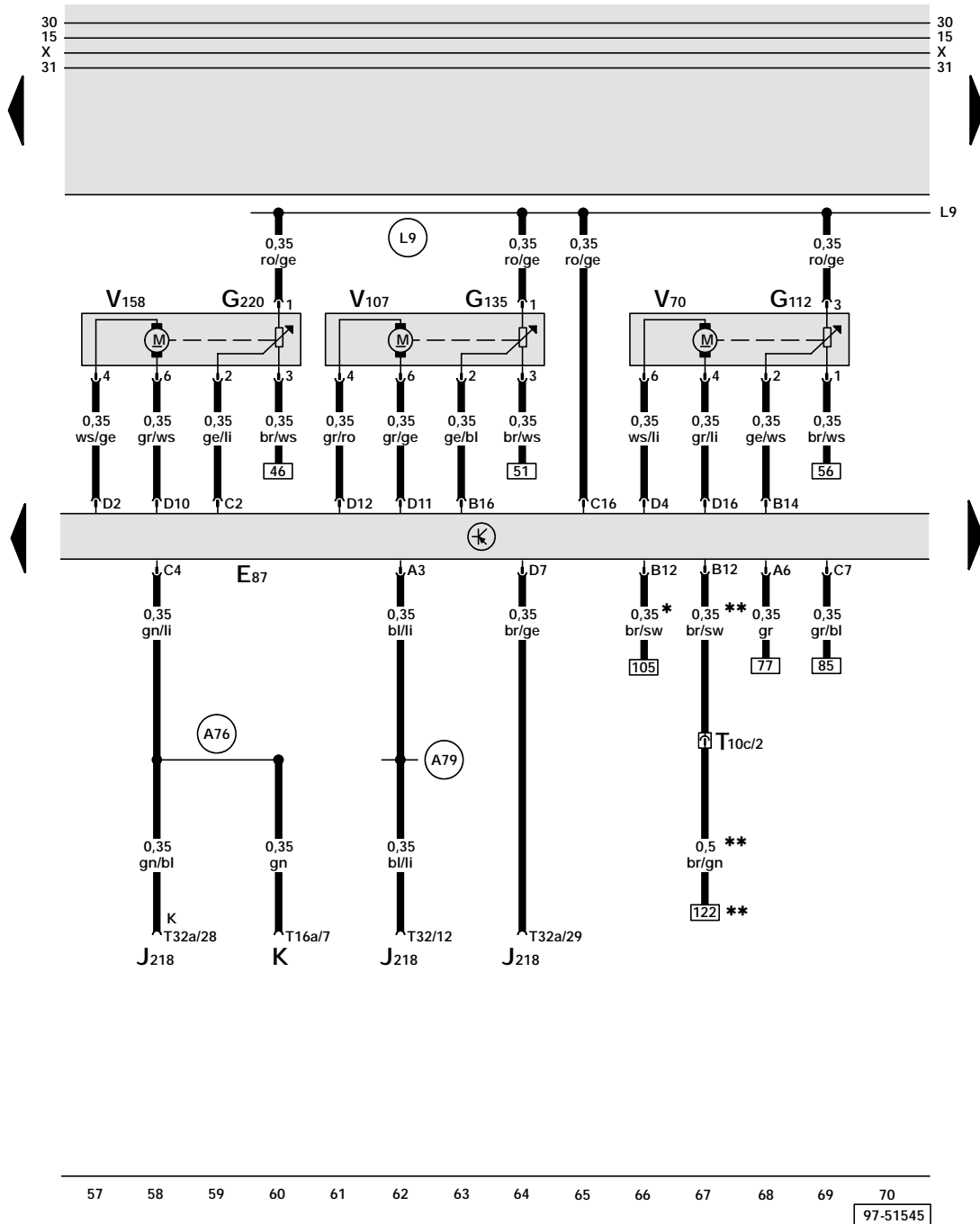

ws = white
 sw = black
 ro = red
 br = brown
 gn = green
 bl = blue
 gr = grey
 li = violet
 ge = yellow

- E87 - A/C Control Head
- G112 - Central Flap Motor Position Sensor
- G135 - Defroster Flap Motor Position Sensor
- G220 - Potentiometer-actuator for temperature flap left
- J218 - Instrument Cluster Combination Processor
- K - Data Link Connector (DLC) Rapid Data Transfer
- T10c - Connector 10 pin, grey, connector station A pillar, left
- T16a - Connector 16 pin, Data Link Connector (DLC)
- T32 - Connector 32 pin, blue, on instrument cluster
- T32a - Connector 32 pin, green, on instrument cluster
- V70 - Central Air Flap Motor
- V107 - Defroster Flap Motor
- V158 - Actuator for temperature flap left

- (A76) - Connector (K-diagnosis wire), in instrument panel wiring harness
- (A79) - Connector (engine overheat warning light), in instrument panel wiring harness
- (L9) - Wire connection -1-, in A/C wiring harness

- * - Vehicles with Coolant FC (Fan Control) Control Module
- ** - Vehicles with Coolant Fan (FC) Relay

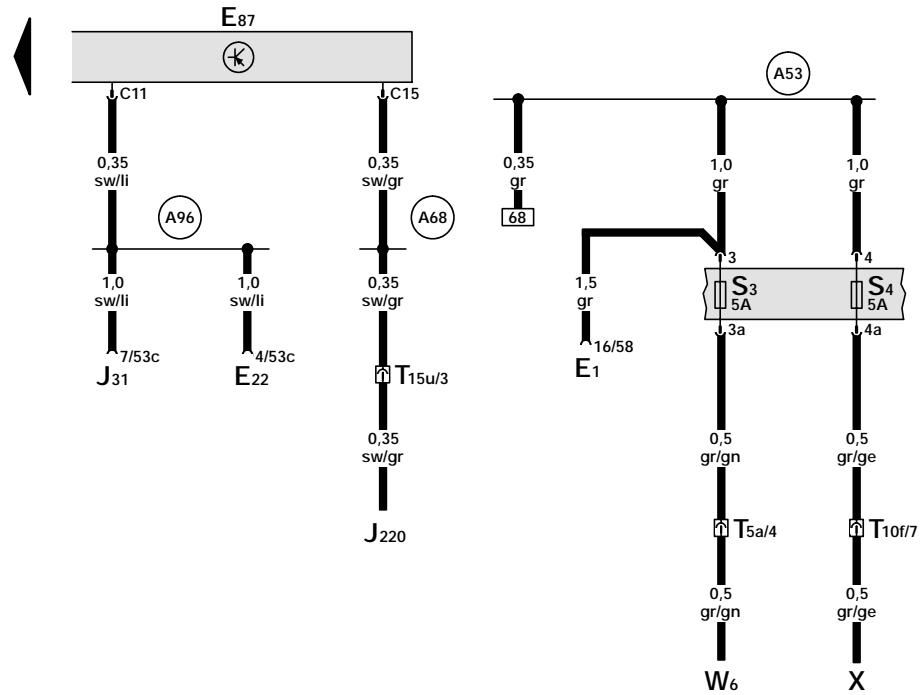
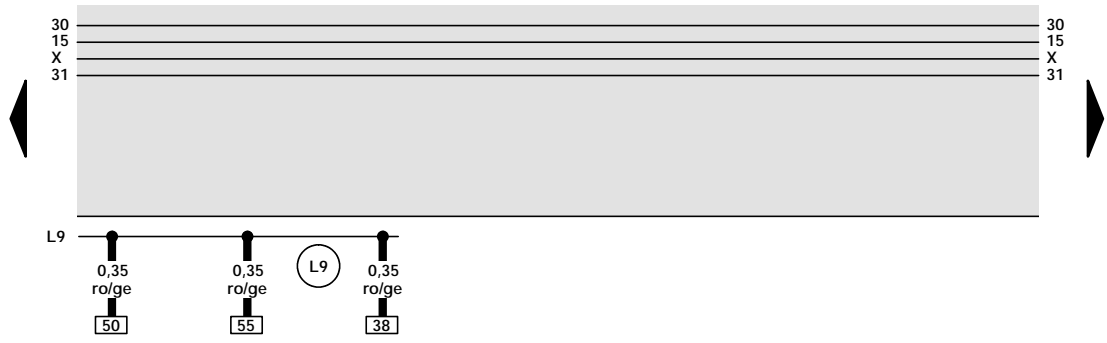

ws = white
 sw = black
 ro = red
 br = brown
 gn = green
 bl = blue
 gr = grey
 li = violet
 ge = yellow

71 72 73 74 75 76 77 78 79 80 81 82 83 84
 97-51546

- E1 - Light switch
- E22 - Windshield Wiper/Washer Switch
- E87 - A/C Control Head
- J31 - Wiper/Washer Intermittent Relay
- J220 - Motronic Engine Control Module (ECM)
- S3 - Fuse
- S4 - Fuse
- T5a - Connector 5 pin, black, behind instrument panel, right
- T10f - Connector 10 pin, brown, connector station A pillar, left
- T15u - Connector 15 pin, red, connector station electronic box plenum chamber
- W6 - Glove Compartment Light
- X - License Plate Light

- (A53) - Plus connection (58b), in instrument panel wiring harness
- (A68) - Connector (C15, A/C), in instrument panel wiring harness
- (A96) - Connector (53a), in instrument panel wiring harness
- (L9) - Wire connection -1-, in A/C wiring harness

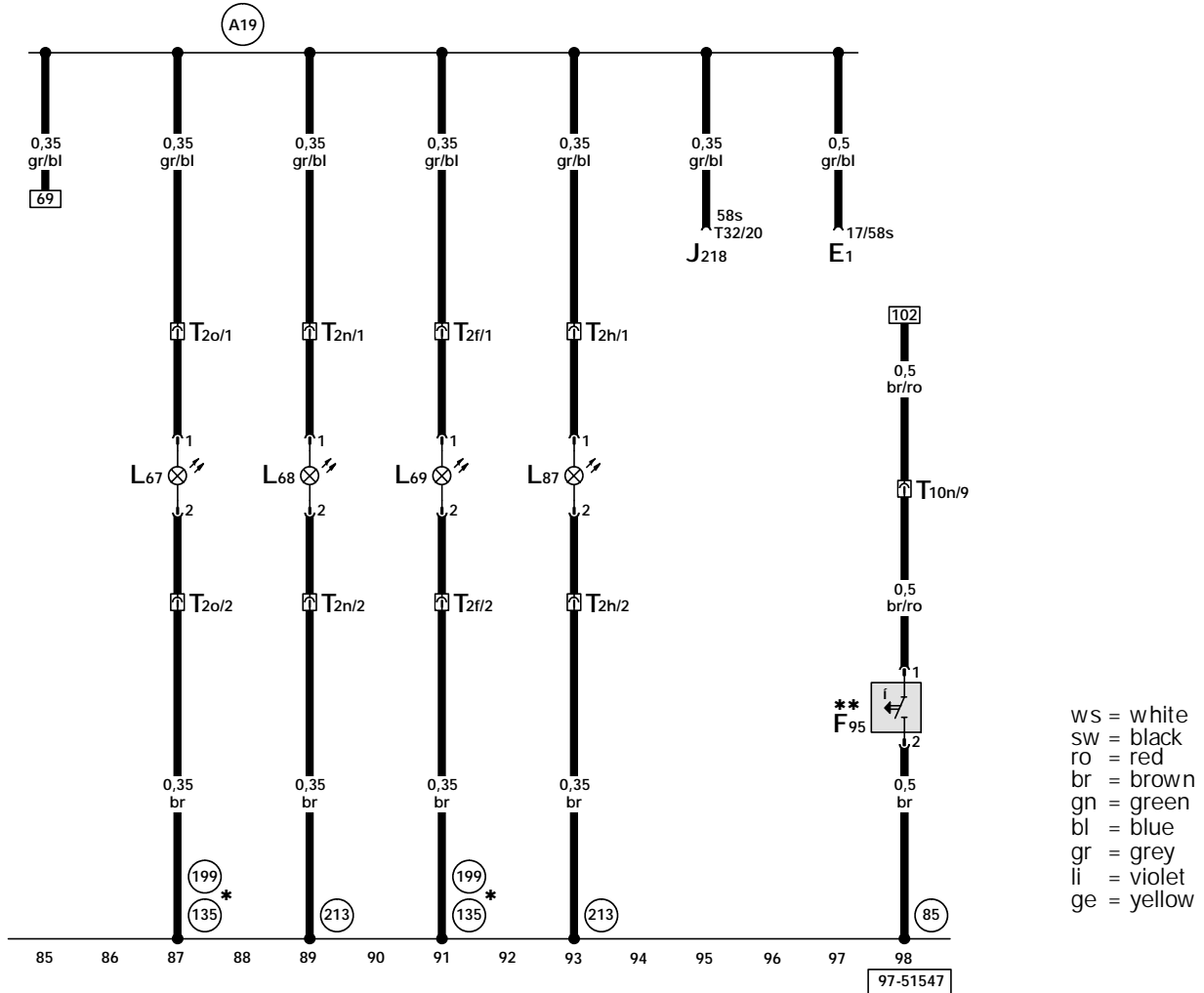
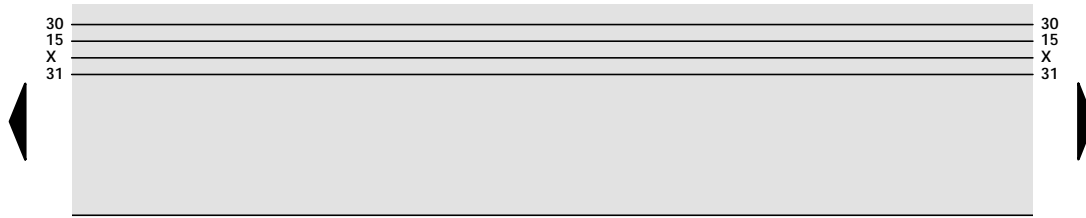

ws = white
 sw = black
 ro = red
 br = brown
 gn = green
 bl = blue
 gr = grey
 li = violet
 ge = yellow

- E1 - Light switch
- F95 - After-Run Coolant Thermal Switch
- J218 - Instrument Cluster Combination Processor
- L67 - Left Instrument Panel Vent Illumination
- L68 - Center Instrument Panel Vent Illumination
- L69 - Right Instrument Panel Vent Illumination
- L87 - Lighting for rearseat outlet center
- T2f - Connector 2 pin, brown, behind instrument panel , right
- T2h - Connector 2 pin, black, in console
- T2n - Connector 2 pin, brown, behind instrument panel, center
- T2o - Connector 2 pin, behind instrument panel, left
- T10n - Connector 10 pin, orange, connector station electronic box plenum chamber
- T32 - Connector 32 pin, blue, on instrument cluster
- (85) - Ground connection -1-, in engine compartment wiring harness
- (135) - Ground connection -2-, in instrument panel wiring harness
- (199) - Ground connection -3-, in instrument panel wiring harness
- (213) - Ground connection, in instrument panel wiring harness
- (A19) - Wire connection (58s), in instrument panel wiring harness
- * - both are possible
- ** - only engine 2,7 I APB

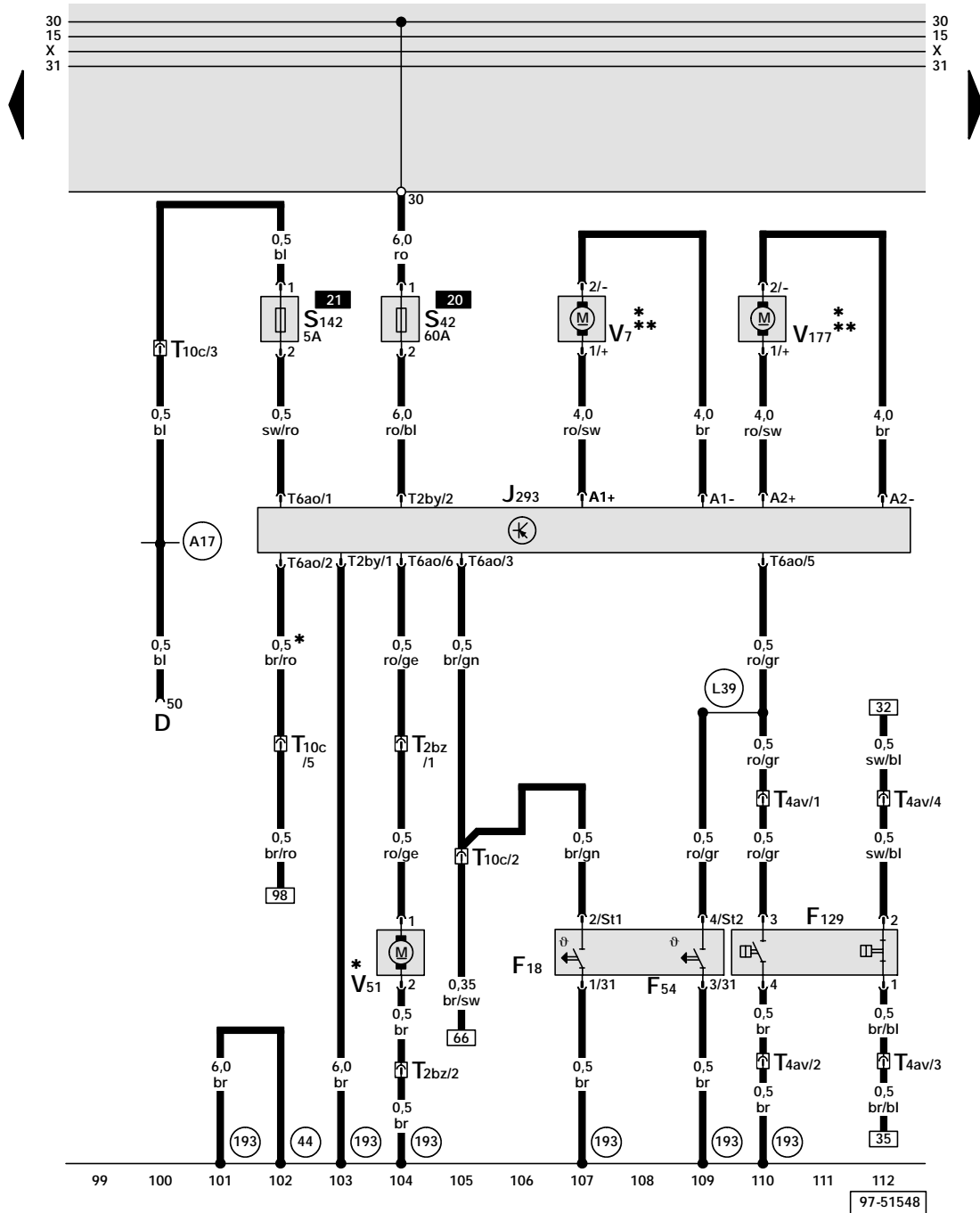

ws = white
 sw = black
 ro = red
 br = brown
 gn = green
 bl = blue
 gr = grey
 li = violet
 ge = yellow

- D - Ignition/Starter Switch
- F18 - Coolant Fan Control (FC) Thermal Switch
- F54 - Coolant Fan Control (FC) Thermal Switch
- F129 - A/C Pressure Switch
- J293 - Coolant FC (Fan Control) Control Module
- S42 - Coolant Fan Fuse
- S142 - Control module fuse for coolant fan
- T2by - Connector 2 pin, on Coolant FC (Fan Control) Control Module
- T2bz - Connector 2 pin, green, for After-Run Coolant Pump
- T4av - Connector 4 pin, red, in engine compartment, left
- T6ao - Connector 6 pin, on Coolant FC (Fan Control) Control Module
- T10c - Connector 10 pin, grey, connector station A pillar, left
- V7 - Coolant Fan
- V51 - After-Run Coolant Pump
- V177 - Coolant fan -2-

- (44) - Ground connection, on left A-pillar, lower part
- (193) - Ground connection -1-, in coolant fan wiring harness
- (A17) - Wire connection (61), in instrument panel wiring harness
- (L39) - Wire connection -1- (A/C Pressure Switch), in Climatronic wiring harness
- * - Vehicles with 6 cylinder engine
- ** - Vehicles with 8 cylinder engine

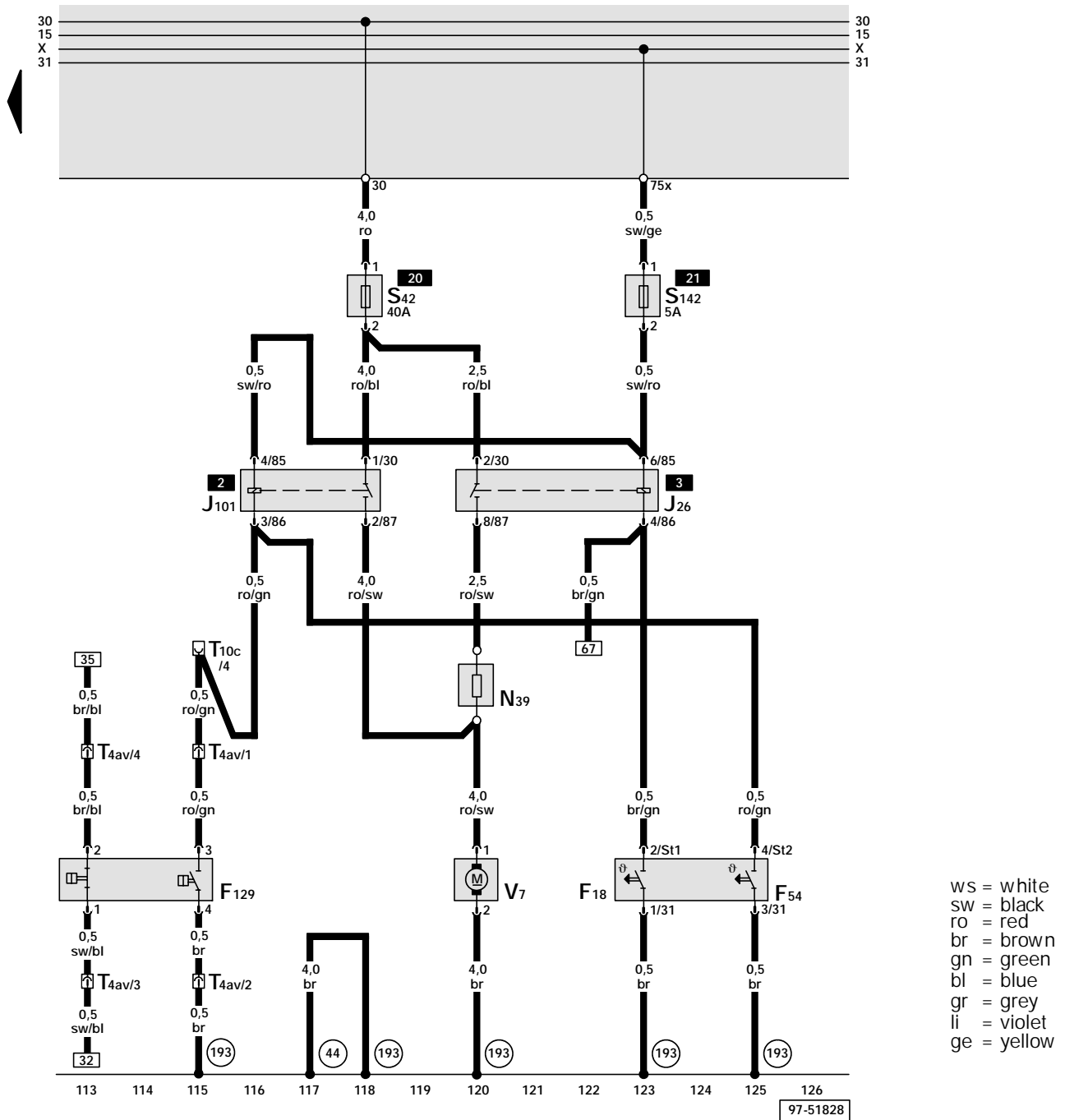

ws = white
 sw = black
 ro = red
 br = brown
 gn = green
 bl = blue
 gr = grey
 li = violet
 ge = yellow

- F18 - Coolant Fan Control (FC) Thermal Switch
- F54 - Coolant Fan Control (FC) Thermal Switch
- F129 - A/C Pressure Switch
- J26 - Coolant Fan control (FC) Relay
- J101 - Second Speed Coolant Fan Control (FC) Relay
- N39 - Coolant Fan Control (FC) Series Resistance
- S42 - Coolant Fan Fuse
- S142 - Control module fuse for coolant fan
- T4av - Connector 4 pin, red, in engine compartment, left
- T10c - Connector 10 pin, grey, connector station A pillar, left
- V7 - Coolant Fan

- (44) - Ground connection, on left A-pillar, lower part
- (193) - Ground connection -1-, in coolant fan wiring harness